



Electrical installation guide

According to IEC international standards

This guide has been written for electrical Engineers who have to design, select electrical equipment, install these equipment and, inspect or maintain low-voltage electrical installations in compliance with international Standards of the International Electrotechnical Commission (IEC). “Which technical solution will guarantee that all relevant safety rules are met?” This question has been a permanent guideline for the elaboration of this document.

An international Standard such as the IEC 60364 series “Low voltage Electrical Installations” specifies extensively the rules to comply with to ensure safety and correct operational functioning of all types of electrical installations. As the Standard must be extensive, and has to be applicable to all types of equipment and the technical solutions in use worldwide, the text of the IEC rules is complex, and not presented in a ready-to-use order. The Standard cannot therefore be considered as a working handbook, but only as a reference document.

The aim of the present guide is to provide a clear, practical and step-by-step explanation for the complete study of an electrical installation, according to IEC 60364 series and other relevant IEC Standards. The first chapter (A) presents the methodology to be used, and refers to all chapters of the guide according to the different steps of the study.

We all hope that you, the reader, will find this handbook genuinely helpful.

Schneider Electric S.A.

Acknowledgements

This guide has been realized by a team of experienced international experts, on the base of IEC 60364 series of standard, and include the latest developments in electrical standardization.

Edition: 2018

Price: 60 €

© Schneider Electric
All rights reserved in all countries

The Electrical Installation Guide is a single document covering the techniques and standards related to low-voltage electrical installations. It is intended for electrical professionals in companies, design offices, inspection organisations, etc.

This Technical Guide is aimed at professional users and is only intended to provide them guidelines for the definition of an industrial, tertiary or domestic electrical installation. Information and guidelines contained in this Guide are provided AS IS. Schneider Electric makes no warranty of any kind, whether express or implied, such as but not limited to the warranties of merchantability and fitness for a particular purpose, nor assumes any legal liability or responsibility for the accuracy, completeness, or usefulness of any information, apparatus, product, or process disclosed in this Guide, nor represents that its use would not infringe privately owned rights. The purpose of this guide is to facilitate the implementation of International installation standards for designers & contractors, but in all cases the original text of International or local standards in force shall prevail.

This new edition has been published to take into account changes in techniques, standards and regulations, in particular electrical installation standard IEC 60364 series.

We thank all the readers of the previous edition of this guide for their comments that have helped improve the current edition. We also thank the many people and organisations, too numerous to name here, who have contributed in one way or another to the preparation of this guide.

Tools for more efficiency in electrical installation design



English



French



Russian



German



Electrical installation Wiki

The Electrical Installation Guide is also available on-line as a wiki in 4 languages:

> in English

en.electrical-installation.org

> in French

fr.electrical-installation.org

> in Russian

ru.electrical-installation.org

> in German

de.electrical-installation.org

Our experts constantly contribute to its evolution. Industry and academic professionals can collaborate too!



Power Management Blog

In the Schneider Electric blog, you will find the best tips about standards, tools, software, safety and latest technical news shared by our experts. You will find even more information about innovations and business opportunities. This is your place to leave us your comments and to engage discussion about your expertise. You might want to share with your Twitter or LinkedIn followers.

blog.schneider-electric.com/power-management-metering-monitoring-power-quality

Foreword



Jacques Peronnet, International Electrotechnical Commission (IEC) TC64 Chairman.

The task of the IEC Technical Committee 64 is to develop and maintain up-to-date standards, in order to ensure:

- the protection of persons and livestock against electrical shock
- the design, verification, and implementation of low-voltage electrical installations.

Developed by IEC TC64, standards such as the IEC 60364 are considered by the international community as the basis for the majority of national low-voltage wiring regulations.

The IEC 60364 series not only covers aspects of electrical installations focused on safety for people who use electricity and who may not be aware of its risks, but also focuses on new uses and all electrical installation needs, such as:

- electromagnetic disturbances
- energy efficiency
- prosumer installations

Consequently, designers, installers, and consumers require precise guidance on the selection and installation of electrical equipment.

Schneider Electric has developed this Electrical Installation Guide, which is dedicated to low-voltage electrical installations. It is based on IEC TC64 standards such as the IEC 60364 series and features additional information to help designers, contractors and controllers to optimize the implementation of low-voltage electrical installations, according to end-user needs.

As TC64 Chairman, I am delighted to be introducing this guide. I am convinced it will be a useful source for all persons involved in the safe and efficient implementation of all low-voltage electrical installations.

Jacques Peronnet

Jacques Peronnet has been working in the Energy Sector for the past 25 years, and with Schneider Electric since 1990.

He has developed comprehensive experience in energy generation up to end-use thanks to various positions within Schneider Electric - in technical roles, marketing and strategy in the field of automation, high- and low-voltage. In his current position he is leading the standardization of low-voltage installations.

In 2017, Jacques Peronnet was appointed Chairman of IEC TC64 and Cenelec TC64.

General contents

General rules of electrical installation design	A
Connection to the MV utility distribution network	B
Connection to the LV utility distribution network	C
MV & LV architecture selection guide for buildings	D
LV Distribution	E
Protection against electric shocks and electrical fires	F
Sizing and protection of conductors	G
LV switchgear: functions & selection	H
Overvoltage protection	J
Energy efficiency in electrical distribution	K
Power Factor Correction	L
Harmonic management	M
Characteristics of particular sources and loads	N
Photovoltaic installations	P
Residential premises and other special locations	Q
EMC guidelines	R
Measurement	S

1	Methodology	A2
2	Rules and statutory regulations	A5
	2.1 Definition of voltage ranges	A5
	2.3 Standards	A6
	2.4 Quality and safety of an electrical installation	A7
	2.5 Initial testing of an installation	A8
	2.6 Put in out of danger the existing electrical installations	A8
	2.7 Periodic check-testing of an installation	A9
	2.9 Environment	A10
3	Installed power loads - Characteristics	A11
	3.1 Induction motors	A11
	3.2 Resistive-type heating appliances and incandescent lamps (conventional or halogen)	A13
	3.3 Fluorescent lamps	A14
	3.4 Discharge lamps	A15
	3.5 LED lamps & fixtures	A16
4	Power loading of an installation	A17
	4.1 Installed power (kW)	A17
	4.2 Installed apparent power (kVA)	A17
	4.3 Estimation of actual maximum kVA demand	A18
	4.4 Example of application of factors k_u and k_s	A21
	4.5 Choice of transformer rating	A22
	4.6 Choice of power-supply sources	A23

1 Methodology

A2

A - General rules of electrical installation design

A§3 - Installed power loads - Characteristics A§4 - Power loading of an installation

B - Connection to the MV utility distribution network

C - Connection to the LV utility distribution network

D - MV & LV architecture selection guide

For the best results in electrical installation design it is recommended to read and to use all the chapters of this guide in the order in which they are presented.

Rules and statutory regulations

Range of low-voltage extends from 0 V to 1000 V in a.c. and from 0 V to 1500 V in d.c. One of the first decision is the selection of type of current between the alternative current which corresponds to the most common type of current through out the world and the direct current. Then designers have to select the most appropriate rated voltage within these ranges of voltages. When connected to a LV public network, the type of current and the rated voltage are already selected and imposed by the Utility.

Compliance with national regulations is then the second priority of the designers of electrical installation. Regulations may be based on national or international standards such as the IEC 60364 series.

Selection of equipment complying with national or international product standards and appropriate verification of the completed installation is a powerful mean for providing a safe installation with the expected quality. Defining and complying with the verification and testing of the electrical installation at its completion as well as periodic time will guarantee the safety and the quality of this installation all along its life cycle. Conformity of equipment according to the appropriate product standards used within the installation is also of prime importance for the level of safety and quality.

Environmental conditions will become more and more stringent and will need to be considered at the design stage of the installation. This may include national or regional regulations considering the material used in the equipment as well as the dismantling of the installation at its end of life.

Installed power loads - Characteristics

A review of all applications needing to be supplied with electricity is to be done. Any possible extensions or modifications during the whole life of the electrical installation are to be considered. Such a review aimed to estimate the current flowing in each circuit of the installation and the power supplies needed.

The total current or power demand can be calculated from the data relative to the location and power of each load, together with the knowledge of the operating modes (steady state demand, starting conditions, non simultaneous operation, etc.)

Estimation of the maximum power demand may use various factors depending on the type of application; type of equipment and type of circuits used within the electrical installation.

From these data, the power required from the supply source and (where appropriate) the number of sources necessary for an adequate supply to the installation is readily obtained.

Local information regarding tariff structures is also required to allow the best choice of connection arrangement to the power-supply network, e.g. at medium voltage or low voltage level.

Connection to the MV public distribution network

Where this connection is made at the Medium Voltage level a consumer-type substation will have to be studied, built and equipped. This substation may be an outdoor or indoor installation conforming to relevant standards and regulations (the low-voltage section may be studied separately if necessary). Metering at medium-voltage or low-voltage is possible in this case.

Connection to the LV utility distribution network

Where the connection is made at the Low Voltage level the installation will be connected to the local power network and will (necessarily) be metered according to LV tariffs.

MV & LV architecture selection guide

The whole electrical system including the MV installation and the LV installation is to be studied as a complete system. The customer expectations and technical parameters will impact the architecture of the system as well as the electrical installation characteristics.

Determination of the most suitable architecture of the MV/LV main distribution and LV power distribution level is often the result of optimization and compromise.

Neutral earthing arrangements are chosen according to local regulations, constraints related to the power-supply, and to the type of loads.

The distribution equipment (panelboards, switchgears, circuit connections, ...) are determined from building plans and from the location and grouping of loads.

The type of premises and allocation can influence their immunity to external disturbances.

1 Methodology

E - LV Distribution

LV distribution

The system earthing is one protective measure commonly used for the protection against electric shocks. These systems earthings have a major impact on the LV electrical installation architecture and they need to be analysed as early as possible. Advantages and drawbacks are to be analysed for a correct selection.

Another aspect needing to be considered at the earlier stage is the external influences. In large electrical installation, different external influences may be encountered and need to be considered independently. As a result of these external influences proper selection of equipment according to their IP or IK codes has to be made.

F - Protection against electric shocks and electrical fires

Protection against electric shocks and electrical fires

Protection against electric shock consists in providing provision for basic protection (protection against direct contact) with provision for fault protection (protection against indirect contact). Coordinated provisions result in a protective measure.

One of the most common protective measures consists in “automatic disconnection of supply” where the provision for fault protection consists in the implementation of a system earthing. Deep understanding of each standardized system (TT, TN and IT system) is necessary for a correct implementation.

Electrical fires are caused by overloads, short circuits and earth leakage currents, but also by electric arcs in cables and connections. These dangerous electric arcs are not detected by residual current devices nor by circuit breakers or fuses. The arc fault detector technology makes it possible to detect dangerous arcs and thus provide additional protection of installations. See chapter F §9 for more information.

G - Sizing and protection of conductors

Sizing and protection of conductors

Selection of cross-sectional-areas of cables or isolated conductors for line conductors is certainly one of the most important tasks of the design process of an electrical installation as this greatly influences the selection of overcurrent protective devices, the voltage drop along these conductors and the estimation of the prospective short-circuit currents: the maximum value relates to the overcurrent protection and the minimum value relates to the fault protection by automatic disconnection of supply. This has to be done for each circuit of the installation.

Similar task is to be done for the neutral conductor and for the Protective Earth (PE) conductor.

H - LV switchgear: functions & selection

LV switchgear: functions & selection

Once the short-circuit current are estimated, protective devices can be selected for the overcurrent protection. Circuit breakers have also other possible functions such as switching and isolation. A complete understanding of the functionalities offered by all switchgear and controlgear within the installation is necessary. Correct selection of all devices can now be done.

A comprehensive understanding of all functionalities offered by the circuit breakers is of prime importance as this is the device offering the largest variety of functions.

J - Overvoltage protection

Overvoltage protection

Direct or indirect lightning strokes can damage electrical equipment at a distance of several kilometres. Operating voltage surges, transient and industrial frequency over-voltage can also produce the same consequences. All protective measures against overvoltage need to be assessed. One of the most used corresponds to the use of Surge Protective Devices (SPD). Their selection; installation and protection within the electrical installation request some particular attention.

K – Energy efficiency in electrical distribution

Energy efficiency in electrical distribution

Implementation of active energy efficiency measures within the electrical installation can produce high benefits for the user or owner: reduced power consumption, reduced cost of energy, better use of electrical equipment. These measures will most of the time request specific design for the installation as measuring electricity consumption either per application (lighting, heating, process...) or per area (floor, workshop) present particular interest for reducing the electricity consumption still keeping the same level of service provided to the user.

L - Power Factor Correction

Reactive energy

The power factor correction within electrical installations is carried out locally, globally or as a combination of both methods. Improving the power factor has a direct impact on the billing of consumed electricity and may also have an impact on the energy efficiency.

M - Harmonic management

N - Characteristics of particular sources and loads

P - Photovoltaic Installations

Q - Residential premises and other special locations

R - EMC guidelines

S - Measurement

A companion tool of the Electrical Installation Guide

Harmonics

Harmonic currents in the network affect the quality of energy and are at the origin of many disturbances as overloads, vibrations, ageing of equipment, trouble of sensitive equipment, of local area networks, telephone networks. This chapter deals with the origins and the effects of harmonics and explain how to measure them and present the solutions.

Particular supply sources and loads

Particular items or equipment are studied:

- Specific sources such as alternators or inverters
- Specific loads with special characteristics, such as induction motors, lighting circuits or LV/LV transformers
- Specific systems, such as direct-current networks.

A green and economical energy

The solar energy development has to respect specific installation rules.

Generic applications

Certain premises and locations are subject to particularly strict regulations: the most common example being residential dwellings.

EMC Guidelines

Some basic rules must be followed in order to ensure Electromagnetic Compatibility. Non observance of these rules may have serious consequences in the operation of the electrical installation: disturbance of communication systems, nuisance tripping of protection devices, and even destruction of sensitive devices.

Measurement

Measurement is becoming more and more an essential part of the electrical installations. Chapter S is an introduction to the different applications of measurements, such as energy efficiency, energy usage analysis, billing, cost allocation, power quality ... It also provides a panorama of the relevant standards for these applications, with a special focus on the IEC 61557-12 related to Power Metering and monitoring devices (PMD).

Ecodial software

Ecodial software^[1] provides a complete design package for LV installations, in accordance with IEC standards and recommendations.

The following features are included:

- Construction of one-line diagrams
- Calculation of short-circuit currents according to several operating modes (normal, back-up, load shedding)
- Calculation of voltage drops
- Optimization of cable sizes
- Required ratings and settings of switchgear and fusegear
- Selectivity of protective devices
- Optimization of switchgear using cascading
- Verification of the protection of people and circuits
- Comprehensive print-out of the foregoing calculated design data

[1] Ecodial is a Schneider Electric software available in several languages and according to different electrical installation standards.

Low-voltage installations are usually governed by a number of regulatory and advisory texts, which may be classified as follows:

- Statutory regulations (decrees, factory acts, etc.)
- Codes of practice, regulations issued by professional institutions, job specifications
- National and international standards for installations
- National and international standards for products

2.1 Definition of voltage ranges

IEC voltage standards and recommendations

Three-phase four-wire or three-wire systems Nominal voltage (V)		Single-phase three-wire systems Nominal voltage (V)
50 Hz	60 Hz	60 Hz
-	120/208	120/240 ^[d]
230 ^[c]	240 ^[c]	-
230/400 ^[a]	230/400 ^[a]	-
-	277/480	-
-	480	-
-	347/600	-
-	600	-
400/690 ^[b]	-	-
1000	-	-

- [a]** The value of 230/400 V is the result of the evolution of 220/380 V and 240/415 V systems which has been completed in Europe and many other countries. However, 220/380 V and 240/415 V systems still exist.
- [b]** The value of 400/690 V is the result of the evolution of 380/660 V systems which has been completed in Europe and many other countries. However, 380/660 V systems still exist.
- [c]** The value of 200 V or 220 V is also used in some countries.
- [d]** The values of 100/200 V are also used in some countries on 50 Hz or 60 Hz systems.

Fig. A1 Standard voltages between 100 V and 1000 V (IEC 60038 Edition 7.0 2009-06)^[1]

Series I Highest voltage for equipment (kV)	Nominal system voltage (kV)		Series II Highest voltage for equipment (kV)	Nominal system voltage (kV)
3.6 ^[a]	3.3 ^[a]	3 ^[a]	4.40 ^[a]	4.16 ^[a]
7.2 ^[a]	6.6 ^[a]	6 ^[a]	-	-
12	11	10	-	-
-	-	-	13.2 ^[b]	12.47 ^[b]
-	-	-	13.97 ^[b]	13.2 ^[b]
-	-	-	14.52 ^[a]	13.8 ^[a]
(17.5)	-	(15)	-	-
24	22	20	-	-
-	-	-	26.4 ^[b] ^[d]	24.94 ^[b] ^[d]
36 ^[c]	33 ^[c]	30 ^[c]	-	-
-	-	-	36.5 ^[b]	34.5 ^[b]
40.5 ^[c]	-	35 ^[c]	-	-

- Note 1:** It is recommended that in any one country the ratio between two adjacent nominal voltages should be not less than two.
- Note 2:** In a normal system of Series I, the highest voltage and the lowest voltage do not differ by more than approximately ±10 % from the nominal voltage of the system. In a normal system of Series II, the highest voltage does not differ by more than +5 % and the lowest voltage by more than -10 % from the nominal voltage of the system.
- [a]** These values should not be used for new public distribution systems.
- [b]** These systems are generally four-wire systems and the values indicated are voltages between phases. The voltage to neutral is equal to the indicated value divided by 1.73.
- [c]** The unification of these values is under consideration.
- [d]** The values of 22.9 kV for nominal voltage and 24.2 kV or 25.8 kV for highest voltage for equipment are also used in some countries.

Fig. A2 AC 3 phases Standard voltages above 1 kV and not exceeding 35 kV (IEC 60038 Edition 7.0 2009)^[2]

[1]

- The lower values in the first and second columns are voltages to neutral and the higher values are voltages between phases. When one value only is indicated, it refers to three-wire systems and specifies the voltage between phases. The lower value in the third column is the voltage to neutral and the higher value is the voltage between lines.
- Voltages in excess of 230/400 V are intended for heavy industrial applications and large commercial premises.
- Concerning supply voltage range, under normal operating conditions, the supply voltage should not differ from the nominal voltage of the system by more than ±10 %.

[2] These systems are generally three-wire systems, unless otherwise indicated. The values indicated are voltages between phases. The values indicated in parentheses should be considered as non-preferred values. It is recommended that these values should not be used for new systems to be constructed in future.

2 Rules and statutory regulations

2.2 Regulations

In most countries, electrical installations shall comply with more than one set of regulations, issued by National Authorities or by recognized private bodies. It is essential to take into account these local constraints before starting the design.

These regulations may be based on national standards derived from the IEC 60364: Low-voltage electrical installations.

2.3 Standards

This Guide is based on relevant IEC standards, in particular IEC 60364. IEC 60364 has been established by engineering experts of all countries in the world comparing their experience at an international level. Currently, the safety principles of IEC 60364 series, IEC 61140, 60479 series and IEC 61201 are the fundamentals of most electrical standards in the world (see table below).

IEC 60038	IEC standard voltages
IEC 60051 series	Direct acting indicating analogue electrical measuring instruments and their accessories
IEC 60071-1	Insulation co-ordination - Definitions, principles and rules
IEC 60076-1	Power transformers - General
IEC 60076-2	Power transformers - Temperature rise for liquid immersed transformers
IEC 60076-3	Power transformers - Insulation levels, dielectric tests and external clearances in air
IEC 60076-5	Power transformers - Ability to withstand short-circuit
IEC 60076-7	Power transformers - Loading guide for oil-immersed power transformers
IEC 60076-10	Power transformers - Determination of sound levels
IEC 60076-11	Power transformers - Dry-type transformers
IEC 60076-12	Power transformers - Loading guide for Dry-type power transformers
IEC 60146-1-1	Semiconductor converters - General requirements and line commutated converters - Specifications of basic requirements
IEC 60255-1	Measuring relays and protection equipment - Common requirements
IEC 60269-1	Low-voltage fuses - General requirements
IEC 60269-2	Low-voltage fuses - Supplementary requirements for fuses for use by authorized persons (fuses mainly for industrial application) - Examples of standardized systems of fuses A to K
IEC 60282-1	High-voltage fuses - Current-limiting fuses
IEC 60287-1-1	Electric cables - Calculation of the current rating - Current rating equations (100 % load factor) and calculation of losses - General
IEC 60364-1	Low-voltage electrical installations - Fundamental principles, assessment of general characteristics, definitions
IEC 60364-4-41	Low-voltage electrical installations - Protection for safety - Protection against electric shock
IEC 60364-4-42	Low-voltage electrical installations - Protection for safety - Protection against thermal effects
IEC 60364-4-43	Low-voltage electrical installations - Protection for safety - Protection against overcurrent
IEC 60364-4-44	Low-voltage electrical installations - Protection for safety - Protection against voltage disturbances and electromagnetic disturbances
IEC 60364-5-51	Low-voltage electrical installations - Selection and erection of electrical equipment - Common rules
IEC 60364-5-52	Low-voltage electrical installations - Selection and erection of electrical equipment - Wiring systems
IEC 60364-5-53	Low-voltage electrical installations - Selection and erection of electrical equipment - Isolation, switching and control
IEC 60364-5-54	Low-voltage electrical installations - Selection and erection of electrical equipment - Earthing arrangements and protective conductors
IEC 60364-5-55	Low-voltage electrical installations - Selection and erection of electrical equipment - Other equipment
IEC 60364-5-56	Low-voltage electrical installations - Selection and erection of electrical equipment - Safety services
IEC 60364-6	Low-voltage electrical installations - Verification
IEC 60364-7-701	Low-voltage electrical installations - Requirements for special installations or locations - Locations containing a bath or shower
IEC 60364-7-702	Low-voltage electrical installations - Requirements for special installations or locations - Swimming pools and fountains
IEC 60364-7-703	Low-voltage electrical installations - Requirements for special installations or locations - Rooms and cabins containing sauna heaters
IEC 60364-7-704	Low-voltage electrical installations - Requirements for special installations or locations - Construction and demolition site installations
IEC 60364-7-705	Low-voltage electrical installations - Requirements for special installations or locations - Agricultural and horticultural premises
IEC 60364-7-706	Low-voltage electrical installations - Requirements for special installations or locations - Conducting locations with restrictive movement
IEC 60364-7-708	Low-voltage electrical installations - Requirements for special installations or locations - Caravan parks, camping parks and similar locations
IEC 60364-7-709	Low-voltage electrical installations - Requirements for special installations or locations - Marinas and similar locations
IEC 60364-7-710	Low-voltage electrical installations - Requirements for special installations or locations - Medical locations
IEC 60364-7-711	Low-voltage electrical installations - Requirements for special installations or locations - Exhibitions, shows and stands
IEC 60364-7-712	Low-voltage electrical installations - Requirements for special installations or locations - Solar photovoltaic (PV) power supply systems
IEC 60364-7-713	Low-voltage electrical installations - Requirements for special installations or locations - Furniture
IEC 60364-7-714	Low-voltage electrical installations - Requirements for special installations or locations - External lighting installations
IEC 60364-7-715	Low-voltage electrical installations - Requirements for special installations or locations - Extra-low-voltage lighting installations
IEC 60364-7-717	Low-voltage electrical installations - Requirements for special installations or locations - Mobile or transportable units
IEC 60364-7-718	Low-voltage electrical installations - Requirements for special installations or locations - Communal facilities and workplaces
IEC 60364-7-721	Low-voltage electrical installations - Requirements for special installations or locations - Electrical installations in caravans and motor caravans
IEC 60364-7-722	Low-voltage electrical installations - Requirements for special installations or locations - Supplies for electric vehicles
IEC 60364-7-729	Low-voltage electrical installations - Requirements for special installations or locations - Operating or maintenance gangways
IEC 60364-7-740	Low-voltage electrical installations - Requirements for special installations or locations - Temporary electrical installations for structures, amusement devices and booths at fairgrounds, amusement parks and circuses
IEC 60364-7-753	Low-voltage electrical installations - Requirements for special installations or locations - Heating cables and embedded heating systems
IEC 60364-8-1	Low-voltage electrical installations - Energy efficiency
IEC 60445	Basic and safety principles for man-machine interface, marking and identification - Identification of equipment terminals, conductors terminations and conductors
IEC 60479-1	Effects of current on human beings and livestock - General aspects
IEC 60479-2	Effects of current on human beings and livestock - Special aspects
IEC 60479-3	Effects of current on human beings and livestock - Effects of currents passing through the body of livestock

IEC 60529	Degrees of protection provided by enclosures (IP code)
IEC 60644	Specification for high-voltage fuse-links for motor circuit applications
IEC 60664	Insulation coordination for equipment within low-voltage systems - all parts
IEC 60715	Dimensions of low-voltage switchgear and controlgear. Standardized mounting on rails for mechanical support of electrical devices in switchgear and controlgear installations.
IEC 60724	Short-circuit temperature limits of electric cables with rated voltages of 1 kV ($U_m = 1.2$ kV) and 3 kV ($U_m = 3.6$ kV)
IEC 60755	General requirements for residual current operated protective devices
IEC 60787	Application guide for the selection of high-voltage current-limiting fuses-link for transformer circuit
IEC 60831-1	Shunt power capacitors of the self-healing type for a.c. systems having a rated voltage up to and including 1000 V - Part 1: General Performance, testing and rating - Safety requirements - Guide for installation and operation
IEC 60831-2	Shunt power capacitors of the self-healing type for a.c. systems having a rated voltage up to and including 1000 V - Part 2: Ageing test, self-healing test and destruction test
IEC 60947-1	Low-voltage switchgear and controlgear - General rules
IEC 60947-2	Low-voltage switchgear and controlgear - Circuit breakers
IEC 60947-3	Low-voltage switchgear and controlgear - Switches, disconnectors, switch-disconnectors and fuse-combination units
IEC 60947-4-1	Low-voltage switchgear and controlgear - Contactors and motor-starters - Electromechanical contactors and motor-starters
IEC 60947-6-1	Low-voltage switchgear and controlgear - Multiple function equipment - Transfer switching equipment
IEC 61000 series	Electromagnetic compatibility (EMC)
IEC 61140	Protection against electric shocks - common aspects for installation and equipment
IEC 61201	Use of conventional touch voltage limits - Application guide
IEC/TR 61439-0	Low-voltage switchgear and controlgear assemblies - Guidance to specifying assemblies
IEC 61439-1	Low-voltage switchgear and controlgear assemblies - General rules
IEC 61439-2	Low-voltage switchgear and controlgear assemblies - Power switchgear and controlgear assemblies
IEC 61439-3	Low-voltage switchgear and controlgear assemblies - Distribution boards intended to be operated by ordinary persons (DBO)
IEC 61439-4	Low-voltage switchgear and controlgear assemblies - Particular requirements for assemblies for construction sites (ACS)
IEC 61439-5	Low-voltage switchgear and controlgear assemblies - Assemblies for power distribution in public networks
IEC 61439-6	Low-voltage switchgear and controlgear assemblies - Busbar trunking systems (busways)
IEC 61557-1	Electrical safety in low voltage distribution systems up to 1000 V a.c. and 1500 V d.c. - Equipment for testing, measuring or monitoring of protective measures - General requirements
IEC 61557-8	Electrical safety in low voltage distribution systems up to 1000 V a.c. and 1500 V d.c. - Equipment for testing, measuring or monitoring of protective measures - Insulation monitoring devices for IT systems
IEC 61557-9	Electrical safety in low voltage distribution systems up to 1000 V a.c. and 1500 V d.c. - Equipment for testing, measuring or monitoring of protective measures - Equipment for insulation fault location in IT systems
IEC 61557-12	Electrical safety in low voltage distribution systems up to 1000 V a.c. and 1500 V d.c. - Equipment for testing, measuring or monitoring of protective measures - Performance measuring and monitoring devices (PMD)
IEC 61558-2-6	Safety of transformers, reactors, power supply units and similar products for supply voltages up to 1100 V - Particular requirements and test for safety isolating transformers and power supply units incorporating isolating transformers
IEC 61643-11	Low-voltage surge protective devices - Surge protective devices connected to low-voltage power systems - Requirements and test methods
IEC 61643-12	Low-voltage surge protective devices - Surge protective devices connected to low-voltage power distribution systems - Selection and application principles
IEC 61643-21	Low voltage surge protective devices - Surge protective devices connected to telecommunications and signalling networks - Performance requirements and testing methods
IEC 61643-22	Low-voltage surge protective devices - Surge protective devices connected to telecommunications and signalling networks - Selection and application principles
IEC 61921	Power capacitors - Low-voltage power factor correction banks
IEC 61936-1	Power installations exceeding 1 kV a.c. - Part 1: Common rules
IEC 62271-1	High-voltage switchgear and controlgear - Common specifications
IEC 62271-100	High-voltage switchgear and controlgear - Alternating-current circuit breakers
IEC 62271-101	High-voltage switchgear and controlgear - Synthetic testing
IEC 62271-102	High-voltage switchgear and controlgear - Alternating current disconnectors and earthing switches
IEC 62271-103	High-voltage switchgear and controlgear - Switches for rated voltages above 1 kV up to and including 52 kV
IEC 62271-105	High-voltage switchgear and controlgear - Alternating current switch-fuse combinations for rated voltages above 1 kV up to and including 52 kV
IEC 62271-200	High-voltage switchgear and controlgear - Alternating current metal-enclosed switchgear and controlgear for rated voltages above 1 kV and up to and including 52 kV
IEC 62271-202	High-voltage switchgear and controlgear - High-voltage/low voltage prefabricated substations
IEC 62305-1	Protection against lightning - Part 1: General principles
IEC 62305-2	Protection against lightning - Part 2: Risk management
IEC 62305-3	Protection against lightning - Part 3: Physical damage to structures and life hazard
IEC 62305-4	Protection against lightning - Part 4: Electrical and electronic systems within structures
IEC 62586-2	Power quality measurement in power supply systems - Part 2: Functional tests and uncertainty requirements
IEC TS 62749	Assessment of power quality - Characteristics of electricity supplied by public networks

2.4 Quality and safety of an electrical installation

In so far as control procedures are respected, quality and safety will be assured only if:

- The design has been done according to the latest edition of the appropriate wiring rules
- The electrical equipment comply with relevant product standards
- The initial checking of conformity of the electrical installation with the standard and regulation has been achieved
- The periodic checking of the installation recommended is respected.

2.5 Initial testing of an installation

Before a utility will connect an installation to its supply network, strict pre-commissioning electrical tests and visual inspections by the authority, or by its appointed agent, must be satisfied.

These tests are made according to local (governmental and/or institutional) regulations, which may differ slightly from one country to another. The principles of all such regulations however, are common, and are based on the observance of rigorous safety rules in the design and realization of the installation.

IEC 60364-6 and related standards included in this guide are based on an international consensus for such tests, intended to cover all the safety measures and approved installation practices normally required for residential, commercial and (the majority of) industrial buildings. Many industries however have additional regulations related to a particular product (petroleum, coal, natural gas, etc.). Such additional requirements are beyond the scope of this guide.

The pre-commissioning electrical tests and visual-inspection checks for installations in buildings include, typically, all of the following:

- Electrical continuity and conductivity tests of protective, equipotential and earth-bonding conductors
- Insulation resistance tests between live conductors and the protective conductors connected to the earthing arrangement
- Test of compliance of SELV (Safety Extra Low Voltage) and PELV (Protection by Extra Low Voltage) circuits or for electrical separation
- Insulation resistance/impedance of floors and walls
- Protection by automatic disconnection of the supply
- For TN, by measurement of the fault loop impedance, and by verification of the characteristics and/or the effectiveness of the associated protective devices (overcurrent protective device and RCD)
- For TT, by measurement of the resistance R_A of the earth electrode of the exposed-conductive-parts, and by verification of the characteristics and/or the effectiveness of the associated protective devices (overcurrent protective device and RCD)
- For IT, by calculation or measurement of the current I_d in case of a first fault at the line conductor or at the neutral, and with the test done for TN system where conditions are similar to TN system in case of a double insulation fault situation, with the test done for TT system where the conditions are similar to TT system in case of a double insulation fault situation.
- Additional protection by verifying the effectiveness of the protective measure
- Polarity test where the rules prohibit the installation of single pole switching devices in the neutral conductor.
- Check of phase sequence in case of multiphase circuit
- Functional test of switchgear and controlgear by verifying their installation and adjustment
- Voltage drop by measuring the circuit impedance or by using diagrams

These tests and checks are basic (but not exhaustive) to the majority of installations, while numerous other tests and rules are included in the regulations to cover particular cases, for example: installations based on class 2 insulation, special locations, etc.

The aim of this guide is to draw attention to the particular features of different types of installation, and to indicate the essential rules to be observed in order to achieve a satisfactory level of quality, which will ensure safe and trouble-free performance. The methods recommended in this guide, modified if necessary to comply with any possible variation imposed by a utility, are intended to satisfy all precommissioning test and inspection requirements.

After verification and testing an initial report must be provided including records of inspection, records of circuits tested together with the test result and possible repairs or improvements of the installation.

2.6 Put in out of danger the existing electrical installations

This subject is in real progress cause of the statistics with origin electrical installation (number of old and recognised dangerous electrical installations, existing installations not in adequation with the future needs etc.).

2.7 Periodic check-testing of an installation

In many countries, all industrial and commercial-building installations, together with installations in buildings used for public gatherings, must be re-tested periodically by authorized agents.

The following tests should be performed:

- Verification of RCD effectiveness and adjustments
- Appropriate measurements for providing safety of persons against effects of electric shock and protection against damage to property against fire and heat
- Confirmation that the installation is not damaged
- Identification of installation defects

Fig. A3 shows the frequency of testing commonly prescribed according to the kind of installation concerned.

Type of installation		Testing frequency
Installations which require the protection of employees	<ul style="list-style-type: none"> ■ Locations at which a risk of degradation, fire or explosion exists ■ Temporary installations at worksites ■ Locations at which MV installations exist ■ Restrictive conducting locations where mobile equipment is used 	Annually
	Other cases	Every 3 years
Installations in buildings used for public gatherings, where protection against the risks of fire and panic are required	According to the type of establishment and its capacity for receiving the public	From one to three years
Residential	According to local regulations	Example: the REBT in Belgium which imposes a periodic control each 20 years

Fig. A3 Frequency of check-tests commonly recommended for an electrical installation

As for the initial verification, a reporting of periodic verification is to be provided.

2.8 Conformity assesement (with standards and specifications) of equipment used in the installation

Conformity of equipment with the relevant standards can be attested in several ways

The conformity assesement of equipment with the relevant standards can be attested:

- By mark of conformity granted by the certification body concerned, or
- By a certificate of conformity issued by a certification body, or
- By a declaration of conformity given by the manufacturer.

Declaration of conformity

As business, the declaration of conformity, including the technical documentation, is generally used in for high voltage equipments or for specific products. In Europe, the CE declaration is a mandatory declaration of conformity.

Note: CE marking

In Europe, the European directives require the manufacturer or his authorized representative to affix the CE marking on his own responsibility. It means that:

- The product meets the legal requirements
- It is presumed to be marketable in Europe.

The CE marking is neither a mark of origin nor a mark of conformity, it completes the declaration of conformity and the technical documents of the equipments.

Certificate of conformity

A certificate of conformity can reinforce the manufacturer's declaration and the customer's confidence. It could be requested by the regulation of the countries, imposed by the customers (Marine, Nuclear,..), be mandatory to guaranty the maintenance or the consistency between the equipments.

Mark of conformity

Marks of conformity are strong strategic tools to validate a durable conformity. It consolidates the confidence with the brand of the manufacturer. A mark of conformity is delivered by certification body if the equipment meets the requirements from an applicable referential (including the standard) and after verification of the manufacturer's quality management system.

Audit on the production and follow up on the equipments are made globally each year.

Quality assurance

A laboratory for testing samples cannot certify the conformity of an entire production run: these tests are called type tests. In some tests for conformity to standards, the samples are destroyed (tests on fuses, for example).

Only the manufacturer can certify that the fabricated products have, in fact, the characteristics stated.

Quality assurance certification is intended to complete the initial declaration or certification of conformity.

As proof that all the necessary measures have been taken for assuring the quality of production, the manufacturer obtains certification of the quality control system which monitors the fabrication of the product concerned. These certificates are issued by organizations specializing in quality control, and are based on the international standard ISO 9001: 2000.

These standards define three model systems of quality assurance control corresponding to different situations rather than to different levels of quality:

- Model 3 defines assurance of quality by inspection and checking of final products
- Model 2 includes, in addition to checking of the final product, verification of the manufacturing process. For example, this method is applied, to the manufacturer of fuses where performance characteristics cannot be checked without destroying the fuse
- Model 1 corresponds to model 2, but with the additional requirement that the quality of the design process must be rigorously scrutinized; for example, where it is not intended to fabricate and test a prototype (case of a custom-built product made to specification).

2.9 Environment

The contribution of the whole electrical installation to sustainable development can be significantly improved through the design of the installation. Actually, it has been shown that an optimised design of the installation, taking into account operation conditions, MV/LV substations location and distribution structure (switchboards, busways, cables), can reduce substantially environmental impacts (raw material depletion, energy depletion, end of life), especially in term of energy efficiency.

Beside its architecture, environmental specification of the electrical component and equipment is a fundamental step for an eco-friendly installation. In particular to ensure proper environmental information and anticipate regulation.

In Europe several Directives concerning electrical equipments have been published, leading the worldwide move to more environment safe products.

a) RoHS Directive (**R**estriction of **H**azardous **S**ubstances): in force since July 2006 and revised on 2012. It aims to eliminate from products six hazardous substances: lead, mercury, cadmium, hexavalent chromium, polybrominated biphenyls (PBB) or polybrominated diphenyl ethers (PBDE) from most of end user electrical products.. Though electrical installations being "large scale fixed installation" are not in the scope, RoHS compliance requirement may be a recommendation for a sustainable installation

b) WEEE Directive (**W**aste of **E**lectrical and **E**lectronic **E**quipment): in force since August 2005 and currently under revision. Its purpose is to improve the end of life treatments for household and non household equipment, under the responsibility of the manufacturers. As for RoHS, electrical installations are not in the scope of this directive. However, End of Life Product information is recommended to optimise recycling process and cost.

c) Energy Related Product, also called Ecodesign. Apart for some equipments like lighting or motors for which implementing measures are compulsory, there are no legal requirements that directly apply to installation. However, trend is to provide electrical equipments with their Environmental Product Declaration, as it is becoming for Construction Products, to anticipate Building Market coming requirements.

d) REACH: (**R**egistration **E**valuation **A**uthorisation of **C**hemicals). In force since 2007, it aims to control chemical use and restrict application when necessary to reduce hazards to people and environment. With regards to Energy Efficiency and installations, it implies any supplier shall, upon request, communicate to its customer the hazardous substances content in its product (so called SVHC, Substances of Very High Concern). Then, an installer should ensure that its suppliers have the appropriate information available

In other parts of the world new legislations will follow the same objectives.

3 Installed power loads - Characteristics

An examination of the actual apparent-power demands of different loads: a necessary preliminary step in the design of a LV installation

The nominal power in kW (P_n) of a motor indicates its rated equivalent mechanical power output.
The apparent power in kVA (P_a) supplied to the motor is a function of the output, the motor efficiency and the power factor.

$$P_a = \frac{P_n}{\eta \cos \varphi}$$

The examination of actual values of apparent-power required by each load enables the establishment of:

- A declared power demand which determines the contract for the supply of energy
- The rating of the MV/LV transformer, where applicable (allowing for expected increased load)
- Levels of load current at each distribution board.

3.1 Induction motors

Current demand

The rated current I_n supplied to the motor is given by the following formulae:

- 3-phase motor: $I_n = P_n \times 1000 / (\sqrt{3} \times U \times \eta \times \cos \varphi)$
- 1-phase motor: $I_n = P_n \times 1000 / (U \times \eta \times \cos \varphi)$

where

I_n : rated current (in amps)

P_n : nominal power (in kW)

U : voltage between phases for 3-phase motors and voltage between the terminals for single-phase motors (in volts). A single-phase motor may be connected phase-to-neutral or phase-to-phase.

η : per-unit efficiency, i.e. output kW / input kW

$\cos \varphi$: power factor, i.e. kW input / kVA input.

Subtransient current and protection setting

- Subtransient current peak value can be very high; typical value is about 12 to 15 times the rms rated value I_n . Sometimes this value can reach 25 times I_n .
- Schneider Electric circuit breakers, contactors and thermal relays are designed to withstand motor starts with very high subtransient current (subtransient peak value can be up to 19 times the rms rated value I_n).
- If unexpected tripping of the overcurrent protection occurs during starting, this means the starting current exceeds the normal limits. As a result, some maximum switchgear withstands can be reached, life time can be reduced and even some devices can be destroyed. In order to avoid such a situation, oversizing of the switchgear must be considered.
- Schneider Electric switchgears are designed to ensure the protection of motor starters against short-circuits. According to the risk, tables show the combination of circuit breaker, contactor and thermal relay to obtain type 1 or type 2 coordination (see chapter N).

Motor starting current

Although high efficiency motors can be found on the market, in practice their starting currents are roughly the same as some of standard motors.

The use of start-delta starter, static soft start unit or variable speed drive allows to reduce the value of the starting current (Example: 4 I_n instead of 7.5 I_n).

See also chapter N §5 "Asynchronous motors" for more information

Compensation of reactive-power (kvar) supplied to induction motors

It is generally advantageous for technical and financial reasons to reduce the current supplied to induction motors. This can be achieved by using capacitors without affecting the power output of the motors.

The application of this principle to the operation of induction motors is generally referred to as "power-factor improvement" or "power-factor correction".

As discussed in chapter L, the apparent power (kVA) supplied to an induction motor can be significantly reduced by the use of shunt-connected capacitors. Reduction of input kVA means a corresponding reduction of input current (since the voltage remains constant).

Compensation of reactive-power is particularly advised for motors that operate for long periods at reduced power.

As noted above $\cos \varphi = \frac{\text{kW input}}{\text{kVA input}}$ so that a kVA input reduction will increase

3 Installed power loads - Characteristics

(i.e. improve) the value of $\cos \varphi$.

The current supplied to the motor, after power-factor correction, is given by:

$$I = I_a \frac{\cos \varphi}{\cos \varphi'}$$

where $\cos \varphi$ is the power factor before compensation and $\cos \varphi'$ is the power factor after compensation, I_a being the original current.

Fig. A4 below shows, in function of motor rated power, standard motor current values for several voltage supplies (IEC 60947-4-1 Annex G)

kW	hp	230 V A	380-415 V A	400 V A	440 - 480 V A	500 V A	690 V A
0.18	-	1.0	-	0.6	-	0.48	0.35
0.25	-	-	-	0.85	-	0.68	0.49
0.37	-	-	-	1.1	-	0.88	0.64
-	1/2	-	1.3	-	1.1	-	-
0.55	-	2.6	-	1.5	-	1.2	0.87
-	3/4	-	1.8	-	1.6	-	-
-	1	-	2.3	-	2.1	-	-
0.75	-	3.3	-	1.9	-	1.5	1.1
1.1	-	4.7	-	2.7	-	2.2	1.6
-	1-1/2	-	3.3	-	3.0	-	-
-	2	-	4.3	-	3.4	-	-
1.5	-	6.3	-	3.6	-	2.9	2.1
2.2	-	8.5	-	4.9	-	3.9	2.8
-	3	-	6.1	-	4.8	-	-
3.0	-	20	-	11.5	-	9.2	6.7
4	-	15	9.7	8.5	7.6	6.8	4.9
-	5	-	9.7	-	7.6	-	-
5.5	-	20	-	11.5	-	9.2	6.7
-	7-1/2	-	14.0	-	11.0	-	-
-	10	-	18.0	-	14.0	-	-
7.5	-	27	-	15.5	-	12.4	8.9
11	-	38.0	-	22.0	-	17.6	12.8
-	15	-	27.0	-	21.0	-	-
-	20	-	34.0	-	27.0	-	-
15	-	51	-	29	-	23	17
18.5	-	61	-	35	-	28	21
-	25	-	44	-	34	-	-
22	-	72	-	41	-	33	24
-	30	-	51	-	40	-	-
-	40	-	66	-	52	-	-
30	-	96	-	55	-	44	32
37	-	115	-	66	-	53	39
-	50	-	83	-	65	-	-
-	60	-	103	-	77	-	-
45	-	140	-	80	-	64	47
55	-	169	-	97	-	78	57
-	75	-	128	-	96	-	-
-	100	-	165	-	124	-	-
75	-	230	-	132	-	106	77
90	-	278	-	160	-	128	93
-	125	-	208	-	156	-	-
110	-	340	-	195	-	156	113
-	150	-	240	-	180	-	-
132	-	400	-	230	-	184	134
-	200	-	320	-	240	-	-
150	-	-	-	-	-	-	-
160	-	487	-	280	-	224	162
185	-	-	-	-	-	-	-
-	250	-	403	-	302	-	-
200	-	609	-	350	-	280	203
220	-	-	-	-	-	-	-
-	300	-	482	-	361	-	-
250	-	748	-	430	-	344	250
280	-	-	-	-	-	-	-
-	350	-	560	-	414	-	-
-	400	-	636	-	474	-	-
300	-	-	-	-	-	-	-

Fig. A4 Rated operational power and currents

3 Installed power loads - Characteristics

kW	hp	230 V	380-415 V	400 V	440 - 480 V	500 V	690 V
		A	A	A	A	A	A
315	-	940	-	540	-	432	313
-	450	-	-	-	515	-	-
335	-	-	-	-	-	-	-
355	-	1061	-	610	-	488	354
-	500	-	786	-	590	-	-
375	-	-	-	-	-	-	-
400	-	1200	-	690	-	552	400
425	-	-	-	-	-	-	-
450	-	-	-	-	-	-	-
475	-	-	-	-	-	-	-
500	-	1478	-	850	-	680	493
530	-	-	-	-	-	-	-
475	-	-	-	-	-	-	-
500	-	1478	-	850	-	680	493
530	-	-	-	-	-	-	-
560	-	1652	-	950	-	760	551
600	-	-	-	-	-	-	-
630	-	1844	-	1060	-	848	615
670	-	-	-	-	-	-	-
710	-	2070	-	1190	-	952	690
750	-	-	-	-	-	-	-
800	-	2340	-	1346	-	1076	780
850	-	-	-	-	-	-	-
900	-	2640	-	1518	-	1214	880
950	-	-	-	-	-	-	-
1000	-	2910	-	1673	-	1339	970

Fig. A4 Rated operational power and currents

3.2 Resistive-type heating appliances and incandescent lamps (conventional or halogen)

See also chapter N §4 "Lighting circuits"

The current demand of a heating appliance or an incandescent lamp is easily obtained from the nominal power P_n quoted by the manufacturer (i.e. cos φ = 1) (see Fig. A5).

Nominal power(kW)	Current demand (A)			
	1-phase 127 V	1-phase 230 V	3-phase 230 V	3-phase 400 V
0.1	0.79	0.43	0.25	0.14
0.2	1.58	0.87	0.50	0.29
0.5	3.94	2.17	1.26	0.72
1	7.9	4.35	2.51	1.44
1.5	11.8	6.52	3.77	2.17
2	15.8	8.7	5.02	2.89
2.5	19.7	10.9	6.28	3.61
3	23.6	13	7.53	4.33
3.5	27.6	15.2	8.72	5.05
4	31.5	17.4	10	5.77
4.5	35.4	19.6	11.3	6.5
5	39.4	21.7	12.6	7.22
6	47.2	26.1	15.1	8.66
7	55.1	30.4	17.6	10.1
8	63	34.8	20.1	11.5
9	71	39.1	22.6	13
10	79	43.5	25.1	14.4

Fig. A5 Current demands of resistive heating and incandescent lighting (conventional or halogen) appliances

3 Installed power loads - Characteristics

The currents are given by:

■ 3-phase case: $I_a = \frac{P_n}{\sqrt{3} U}$ [1]

■ 1-phase case: $I_a = \frac{P_n}{U}$ [1]

where U is the voltage between the terminals of the equipment.

For an incandescent lamp, the use of halogen gas allows a more concentrated light source. The light output is increased and the lifetime of the lamp is doubled.

Note: At the instant of switching on, the cold filament gives rise to a very brief but intense peak of current.

3.3 Fluorescent lamps

See also chapter N §4 "Lighting circuits".

Fluorescent lamps and related equipment

The power P_n (watts) indicated on the tube of a fluorescent lamp does not include the power dissipated in the ballast.

The current is given by:

$$I_a = \frac{P_{ballast} + P_n}{U \cos \varphi}$$

Where U = the voltage applied to the lamp, complete with its related equipment.

If no power-loss value is indicated for the ballast, a figure of 25 % of P_n may be used.

Standard tubular fluorescent lamps

With (unless otherwise indicated):

- cos φ = 0.6 with no power factor (PF) correction [2] capacitor
- cos φ = 0.86 with PF correction [2] (single or twin tubes)
- cos φ = 0.96 for electronic ballast.

If no power-loss value is indicated for the ballast, a figure of 25 % of P_n may be used.

Fig. A6 gives these values for different arrangements of ballast.

Arrangement of lamps, starters and ballasts	Tube power (W) [a]	Current (A) at 230 V			Tube length (cm)
		Magnetic ballast Without PF correction capacitor	With PF correction capacitor	Electronic ballast	
Single tube	18	0.20	0.14	0.10	60
	36	0.33	0.23	0.18	120
	58	0.50	0.36	0.28	150
Twin tubes	2 x 18		0.28	0.18	60
	2 x 36		0.46	0.35	120
	2 x 58		0.72	0.52	150

[a] Power in watts marked on tube

Fig. A6 Current demands and power consumption of commonly-dimensioned fluorescent lighting tubes (at 230 V-50 Hz)

Compact fluorescent lamps

Compact fluorescent lamps have the same characteristics of economy and long life as classical tubes. They are commonly used in public places which are permanently illuminated (for example: corridors, hallways, bars, etc.) and can be mounted in situations otherwise illuminated by incandescent lamps (see **Fig. A7**).

[1] I_a in amps; U in volts. P_n is in watts. If P_n is in kW, then multiply the equation by 1000.

[2] "Power-factor correction" is often referred to as "compensation" in discharge-lighting-tube terminology. Cos φ is approximately 0.95 (the zero values of V and I are almost in phase) but the power factor is 0.5 due to the impulsive form of the current, the peak of which occurs "late" in each half cycle.

3 Installed power loads - Characteristics

Type of lamp	Lamp power (W)	Current at 230 V (A)
Separated ballast lamp	10	0.080
	18	0.110
	26	0.150
Integrated ballast lamp	8	0.075
	11	0.095
	16	0.125
	21	0.170

Fig. A7 Current demands and power consumption of compact fluorescent lamps (at 230 V-50 Hz)

The power in watts indicated on the tube of a discharge lamp does not include the power dissipated in the ballast.

3.4 Discharge lamps

See also chapter N §4 "Lighting circuits".

Fig. A8 gives the current taken by a complete unit, including all associated ancillary equipment.

These lamps depend on the luminous electrical discharge through a gas or vapour of a metallic compound, which is contained in a hermetically-sealed transparent envelope at a pre-determined pressure. These lamps have a long start-up time, during which the current I_a is greater than the nominal current I_n . Power and current demands are given for different types of lamp (typical average values which may differ slightly from one manufacturer to another).

Type of lamp (W)	Power demand (W)		Current I_n (A)			Starting		Luminous efficiency (lumens per watt)	Average lifetime of lamp (h)	Utilization
	at 230 V	400 V	PF not corrected	PF corrected	PF corrected	$x I_n$	Period (mins)			
High-pressure sodium vapour lamps										
50	60		0.76		0.3	1.4 to 1.6	4 to 6	80 to 120	9000	<ul style="list-style-type: none"> Lighting of large halls Outdoor spaces Public lighting
70	80		1		0.45					
100	115		1.2		0.65					
150	168		1.8		0.85					
250	274		3		1.4					
400	431		4.4		2.2					
1000	1055		10.45		4.9					
Low-pressure sodium vapour lamps										
26	34.5		0.45		0.17	1.1 to 1.3	7 to 15	100 to 200	8000 to 12000	<ul style="list-style-type: none"> Lighting of motorways Security lighting, railway platforms Platform, storage areas
36	46.5				0.22					
66	80.5				0.39					
91	105.5				0.49					
131	154				0.69					
Mercury vapour + metal halide (also called metal-iodide)										
70	80.5		1		0.40	1.7	3 to 5	70 to 90	6000	<ul style="list-style-type: none"> Lighting of very large areas by projectors (for example: sport stadiums, etc.)
150	172		1.80		0.88					
250	276		2.10		1.35					
400	425		3.40		2.15					
1000	1046		8.25		5.30					
2000	2092	2052	16.5	8.60	10.50					
Mercury vapour + fluorescent substance (fluorescent bulb)										
50	57		0.6		0.30	1.7 to 2	3 to 6	40 to 60	8000 to 12000	<ul style="list-style-type: none"> Workshops with very high ceilings (halls, hangars) Outdoor lighting Low light output [a]
80	90		0.8		0.45					
125	141		1.15		0.70					
250	268		2.15		1.35					
400	421		3.25		2.15					
700	731		5.4		3.85					
1000	1046		8.25		5.30					
2000	2140	2080	15		11					

[a] Replaced by sodium vapour lamps.

Note: these lamps are sensitive to voltage dips. They extinguish if the voltage falls to less than 50 % of their nominal voltage, and will not re-ignite before cooling for approximately 4 minutes.

Note: Sodium vapour low-pressure lamps have a light-output efficiency which is superior to that of all other sources. However, use of these lamps is restricted by the fact that the yellow-orange colour emitted makes colour recognition practically impossible.

Fig. A8 Current demands of discharge lamps

3 Installed power loads - Characteristics

A16

3.5 LED lamps & fixtures

See also chapter N §4 "Lighting circuits"

A lamp or luminaire with LED technology is powered by a driver:

- can be integrated into the bulb (tube or lamp for retrofit) : in this case refer to the power indicated on the lamp
- if separated : in that case it is necessary to take into account the power dissipated in the driver and the power indicated for one or several associated LED modules.

This technology has a very short start-up time. On the other hand, the inrush current at the powering is generally much higher than for fluorescent lamp with electronic ballast.

Note: The power in Watts indicated on the LED module with a separated driver doesn't include the power dissipated in the driver.

Power demand (W) at 230 V	Power factor	Starting			Luminous efficiency (lumens/watt)	Average lifetime (h)	Utilization
		Inrush current I_p/I_n	Inrush current time	Full Time to start			
3 to 400 W	> 0.9	Up to 250	< 250 μ s	< 0.5 to 1 sec	100 to 140	20000 to 50000	■ All lighting applications in all domains (housing, commercial and industrial building, infrastructure)

Fig. A9 Main characteristics of LED lamps & fixtures

4 Power loading of an installation

In order to design an installation, the actual maximum load demand likely to be imposed on the power-supply system must be assessed.

To base the design simply on the arithmetic sum of all the loads existing in the installation would be extravagantly uneconomical, and bad engineering practice.

The aim of this chapter is to show how some factors taking into account the diversity (non simultaneous operation of all appliances of a given group) and utilization (e.g. an electric motor is not generally operated at its full-load capability, etc.) of all existing and projected loads can be assessed.

The values given are based on experience and on records taken from actual installations. In addition to providing basic installation-design data on individual circuits, the results will provide a global value for the installation, from which the requirements of a supply system (distribution network, MV/LV transformer, or generating set) can be specified.

The installed power is the sum of the nominal powers of all power consuming devices in the installation. This is not the power to be actually supplied in practice.

4.1 Installed power (kW)

Most electrical appliances and equipments are marked to indicate their nominal power rating (P_n).

The installed power is the sum of the nominal powers of all power-consuming devices in the installation. This is not the power to be actually supplied in practice. This is the case for electric motors, where the power rating refers to the output power at its driving shaft. The input power consumption will evidently be greater.

Fluorescent and discharge lamps associated with stabilizing ballasts, are other cases in which the nominal power indicated on the lamp is less than the power consumed by the lamp and its ballast.

Methods of assessing the actual power consumption of motors and lighting appliances are given in Section 3 of this Chapter.

The power demand (kW) is necessary to choose the rated power of a generating set or battery, and where the requirements of a prime mover have to be considered.

For a power supply from a LV public-supply network, or through a MV/LV transformer, the significant quantity is the apparent power in kVA.

4.2 Installed apparent power (kVA)

The installed apparent power is commonly assumed to be the arithmetical sum of the kVA of individual loads. The maximum estimated kVA to be supplied however is not equal to the total installed kVA.

The apparent-power demand of a load (which might be a single appliance) is obtained from its nominal power rating (corrected if necessary, as noted above for motors, etc.) and the application of the following coefficients:

η = the per-unit efficiency = output kW / input kW

$\cos \phi$ = the power factor = kW / kVA

The apparent-power kVA demand of the load

$$P_a = P_n / (\eta \times \cos \phi)$$

From this value, the full-load current I_a (A)^[1] taken by the load will be:

$$\blacksquare I_a = \frac{P_a \times 10^3}{V}$$

for single phase-to-neutral connected load

$$\blacksquare I_a = \frac{P_a \times 10^3}{\sqrt{3} \times U}$$

for three-phase balanced load where:

V = phase-to-neutral voltage (volts)

U = phase-to-phase voltage (volts)

It may be noted that, strictly speaking, the total kVA of apparent power is not the arithmetical sum of the calculated kVA ratings of individual loads (unless all loads are at the same power factor).

It is common practice however, to make a simple arithmetical summation, the result of which will give a kVA value that exceeds the true value by an acceptable "design margin".

[1] For greater precision, account must be taken of the factor of maximum utilization as explained below in 4.3.

4 Power loading of an installation

When some or all of the load characteristics are not known, the values shown in Fig. A10 may be used to give a very approximate estimate of VA demands (individual loads are generally too small to be expressed in kVA or kW). The estimates for lighting loads are based on floor areas of 500 m².

Fluorescent lighting (corrected to cos φ = 0.86)		
Type of application	Estimated (VA/m ²) fluorescent tube with industrial reflector [a]	Average lighting level (lux = lm/m ²)
Roads and highways storage areas, intermittent work	7	150
Heavy-duty works: fabrication and assembly of very large work pieces	14	300
Day-to-day work: office work	24	500
Fine work: drawing offices high-precision assembly workshops	41	800
Power circuits		
Type of application	Estimated (VA/m ²)	
Pumping station compressed air	3 to 6	
Ventilation of premises	23	
Electrical convection heaters: private houses flats and apartments	115 to 146 90	
Offices	25	
Dispatching workshop	50	
Assembly workshop	70	
Machine shop	300	
Painting workshop	350	
Heat-treatment plant	700	

[a] example: 65 W tube (ballast not included), flux 5,100 lumens (lm), luminous efficiency of the tube = 78.5 lm / W.

Fig. A10 Estimation of installed apparent power

4.3 Estimation of actual maximum kVA demand

All individual loads are not necessarily operating at full rated nominal power nor necessarily at the same time. Factors k_u and k_s allow the determination of the maximum power and apparent-power demands actually required to dimension the installation.

Factor of maximum utilization (k_u)

In normal operating conditions the power consumption of a load is sometimes less than that indicated as its nominal power rating, a fairly common occurrence that justifies the application of an utilization factor (k_u) in the estimation of realistic values.

This factor must be applied to each individual load, with particular attention to electric motors, which are very rarely operated at full load.

In an industrial installation this factor may be estimated on an average at 0.75 for motors.

For incandescent-lighting loads, the factor always equals 1.

For socket-outlet circuits, the factors depend entirely on the type of appliances being supplied from the sockets concerned.

For Electric Vehicle the utilization factor will be systematically estimated to 1, as it takes a long time to load completely the batteries (several hours) and a dedicated circuit feeding the charging station or wall box will be required by standards.

4 Power loading of an installation

The determination of ks factors is the responsibility of the designer, since it requires a detailed knowledge of the installation and the conditions in which the individual circuits are to be exploited. For this reason, it is not possible to give precise values for general application.

Diversity factor - Coincidence factor (ks)

It is a matter of common experience that the simultaneous operation of all installed loads of a given installation never occurs in practice, i.e. there is always some degree of diversity and this fact is taken into account for estimating purposes by the use of a factor (ks).

This factor is defined in IEC 60050 - International Electrotechnical Vocabulary, as follows:

■ **Coincidence factor:** the ratio, expressed as a numerical value or as a percentage, of the simultaneous maximum demand of a group of electrical appliances or consumers within a specified period, to the sum of their individual maximum demands within the same period. As per this definition, the value is always ≤ 1 and can be expressed as a percentage

■ **Diversity factor:** the reciprocal of the coincidence factor. It means it will always be ≥ 1 .

Note: In practice, the most commonly used term is the diversity factor, but it is used in replacement of the coincidence factor, thus will be always ≤ 1 . The term "simultaneity factor" is another alternative that is sometimes used.

The factor ks is applied to each group of loads (e.g. being supplied from a distribution or sub-distribution board).

The following tables are coming from local standards or guides, not from international standards. They should only be used as examples of determination of such factors.

Diversity factor for an apartment block

Some typical values for this case are given in Fig. A11, and are applicable to domestic consumers without electrical heating, and supplied at 230/400 V (3-phase 4-wires). In the case of consumers using electrical heat-storage units for space

Number of downstream consumers	Diversity factor (ks)
2 to 4	1
5 to 9	0.78
10 to 14	0.63
15 to 19	0.53
20 to 24	0.49
25 to 29	0.46
30 to 34	0.44
35 to 39	0.42
40 to 49	0.41
50 and more	0.38

Fig. A11 Example of diversity factors for an apartment block as defined in French standard NFC14-100, and applicable for apartments without electrical heating

heating, a factor of 0.8 is recommended, regardless of the number of consumers.

Example (see Fig. A12):

5 storeys apartment building with 25 consumers, each having 6 kVA of installed load.

The total installed load for the building is: $36 + 24 + 30 + 36 + 24 = 150$ kVA

The apparent-power supply required for the building is: $150 \times 0.46 = 69$ kVA

From Fig. A12, it is possible to determine the magnitude of currents in different sections of the common main feeder supplying all floors. For vertical rising mains fed at ground level, the cross-sectional area of the conductors can evidently be progressively reduced from the lower floors towards the upper floors.

These changes of conductor size are conventionally spaced by at least 3-floor intervals.

In the example, the current entering the rising main at ground level is:

$$\frac{150 \times 0.46 \times 10^3}{400 \sqrt{3}} = 100 \text{ A}$$

the current entering the third floor is:

$$\frac{(36 + 24) \times 0.63 \times 10^3}{400 \sqrt{3}} = 55 \text{ A}$$

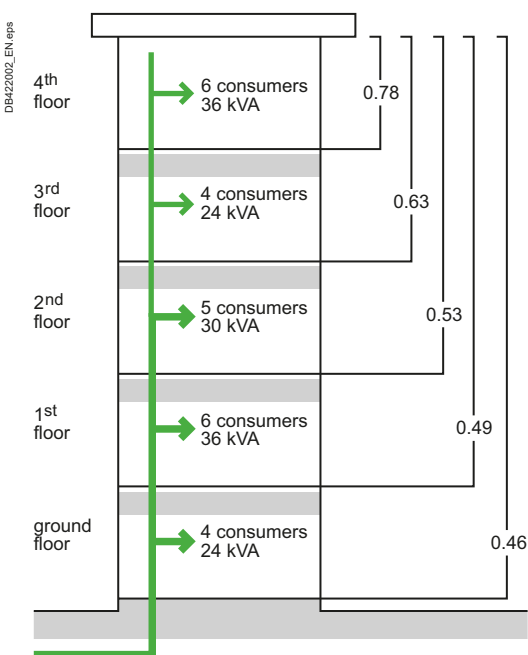


Fig. A12 Application of the diversity factor (ks) to an apartment block of 5 storeys

4 Installed power loads - Characteristics

A20

Rated Diversity Factor for distribution switchboards

The standards IEC61439-1 and 2 define in a similar way the Rated Diversity Factor for distribution switchboards (in this case, always ≤ 1).

IEC61439-2 also states that, in the absence of an agreement between the assembly manufacturer (panel builder) and user concerning the actual load currents (diversity factors), the assumed loading of the outgoing circuits of the assembly or group of outgoing circuits may be based on the values in **Fig. A13**.

If the circuits are mainly for lighting loads, it is prudent to adopt k_s values close to unity.

Type of load	Assumed loading factor
Distribution - 2 and 3 circuits	0.9
Distribution - 4 and 5 circuits	0.8
Distribution - 6 to 9 circuits	0.7
Distribution - 10 or more circuits	0.6
Electric actuator	0.2
Motors ≤ 100 kW	0.8
Motors > 100 kW	1.0

Fig. A13 Rated diversity factor for distribution boards (cf IEC61439-2 table 101)

Diversity factor according to circuit function

k_s factors which may be used for circuits supplying commonly-occurring loads, are shown in **Fig. A14**. It is provided in French practical guide UTE C 15-105.

Circuit function	Diversity factor (k_s)						
Lighting	1						
Heating and air conditioning	1						
Socket-outlets	0.1 to 0.2 ^[a]						
Lifts and catering hoist ^[b]	<table border="0"> <tr> <td>■ For the most powerful motor</td> <td>1</td> </tr> <tr> <td>■ For the second most powerful motor</td> <td>0.75</td> </tr> <tr> <td>■ For all motors</td> <td>0.60</td> </tr> </table>	■ For the most powerful motor	1	■ For the second most powerful motor	0.75	■ For all motors	0.60
■ For the most powerful motor	1						
■ For the second most powerful motor	0.75						
■ For all motors	0.60						

^[a] In certain cases, notably in industrial installations, this factor can be higher.

^[b] The current to take into consideration is equal to the nominal current of the motor, increased by a third of its starting current.

Fig. A14 Diversity factor according to circuit function (see UTE C 15-105 table AC)

4 Installed power loads - Characteristics

4.4 Example of application of factors k_u and k_s

An example in the estimation of actual maximum kVA demands at all levels of an installation, from each load position to the point of supply is given Fig. A15.

In this example, the total installed apparent power is 126.6 kVA, which corresponds to an actual (estimated) maximum value at the LV terminals of the MV/LV transformer of 65 kVA only.

Note: in order to select cable sizes for the distribution circuits of an installation, the current I (in amps) through a circuit is determined from the equation:

$$I = \frac{kVA \times 10^3}{U \sqrt{3}}$$

where kVA is the actual maximum 3-phase apparent-power value shown on the diagram for the circuit concerned, and U is the phase-to-phase voltage (in volts).

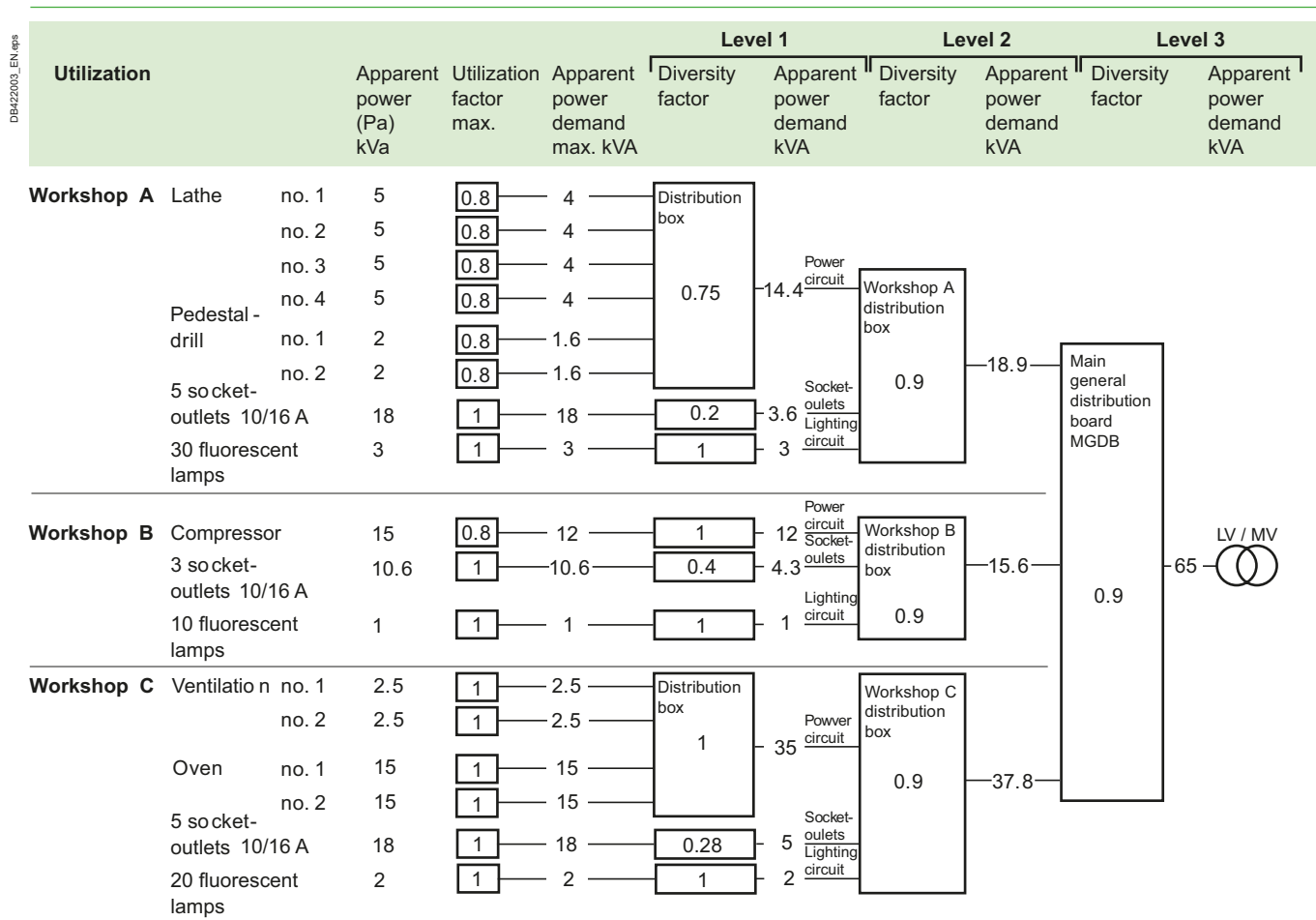


Fig. A15 An example in estimating the maximum predicted loading of an installation (the factor values used are for demonstration purposes only)

4 Installed power loads - Characteristics

A22

4.5 Choice of transformer rating

When an installation is to be supplied directly from a MV/LV transformer and the maximum apparent-power loading of the installation has been determined, a suitable rating for the transformer can be decided, taking into account the following considerations (see Fig. A16):

- The possibility of improving the power factor of the installation (see chapter L)
- Anticipated extensions to the installation
- Installation constraints (e.g. temperature)
- Standard transformer ratings.

The nominal full-load current I_n on the LV side of a 3-phase transformer is given by:

$$I_n = \frac{Pa \times 10^3}{U \sqrt{3}}$$

where

- Pa = kVA rating of the transformer
- U = phase-to-phase voltage at no-load in volts (237 V or 410 V)
- I_n is in amperes.

For a single-phase transformer:

$$I_n = \frac{Pa \times 10^3}{V}$$

where:

- V = voltage between LV terminals at no-load (in volts)

Simplified equation for 400 V (3-phase load)

- $I_n = \text{kVA} \times 1.4$

The IEC standard for power transformers is IEC 60076.

Apparent power kVA	In (A)	
	237 V [a]	410 V [a]
100	244	141
160	390	225
250	609	352
315	767	444
400	974	563
500	1218	704
630	1535	887
800	1949	1127
1000	2436	1408
1250	3045	1760
1600	3898	2253
2000	4872	2816
2500	6090	3520
3150	7673	4436

[a] transformer no-load voltage.

Fig. A16 Standard apparent powers for MV/LV transformers and related nominal output currents

4.6 Choice of power-supply sources

The importance of maintaining a continuous supply raises the question of the use of standby-power plant. The choice and characteristics of these alternative sources are part of the architecture selection, as described in chapter D.

For the main source of supply the choice is generally between a connection to the MV or the LV network of the power-supply utility. In some cases main source of supply can be rotating generators in the case of remote installations with difficult access to the local Utility public grid (MV or LV) or where the reliability of the public grid does not have the minimum level of reliability expected.

In practice, connection to a MV source may be necessary where the load exceeds (or is planned eventually to exceed) a certain level - generally of the order of 250 kVA, or if the quality of service required is greater than that normally available from a LV network.

Moreover, if the installation is likely to cause disturbance to neighbouring consumers, when connected to a LV network, the supply authorities may propose a MV service.

Supplies at MV can have certain advantages: in fact, a MV consumer:

- Is not disturbed by other consumers, which could be the case at LV
- Is free to choose any type of LV earthing system
- Has a wider choice of economic tariffs
- Can accept very large increases in load.

It should be noted, however, that:

- The consumer is the owner of the MV/LV substation and, in some countries, he must build equip and maintain it at his own expense. The power utility can, in certain circumstances, participate in the investment, at the level of the MV line for example
- A part of the connection costs can, for instance, often be recovered if a second consumer is connected to the MV line within a certain time following the original consumer's own connection
- The consumer has access only to the LV part of the installation, access to the MV part being reserved to the utility personnel (meter reading, operations, etc.). However, in certain countries, the MV protective circuit breaker (or fused load-break switch) can be operated by the consumer
- The type and location of the substation are agreed between the consumer and the utility.

More and more renewable energy sources such as photovoltaic panels are used to supply low-voltage electrical installations. In some case these PV panels are connected in parallel to the Utility grid or these PV panels are used in an autonomous mode without connection to the public grid. Conversion from d.c. to a.c. is then necessary as rated voltage of these PV panels are higher and higher (few hundreds volts) and also because PV panels produce d.c. currents.

See also chapter P "Photovoltaic installations" for more details.

A - General rules of electrical installation design

A24

Connection to the MV utility distribution network

1	Power supply at medium voltage	B2
	1.1 Main requirements for power supply at Medium Voltage and typical architectures	B2
	1.2 Medium voltages and current values according to IEC Standards.....	B4
	1.3 Different types of MV power supply	B5
	1.4 Some practical issues concerning MV distribution networks	B7
2	Procedure for the establishment of a new substation	B10
	2.1 Preliminary information.....	B10
	2.2 Information and requirements provided by the utility	B11
	2.3 Commissioning, testing, energizing	B11
3	Protection against electrical hazards, faults and mis-operations in electrical installations	B12
	3.1 General principle of protection against electrical shocks in electrical installations	B12
	3.2 Protection of transformer and circuits	B14
	3.3 MV/LV transformer protection with circuit breaker	B17
	3.4 Interlocks and conditioned operations	B19
4	The consumer substation with LV metering	B23
	4.1 Definition	B23
	4.2 Functions of a substation with LV metering.....	B23
	4.3 Choice of LV equipment	B24
5	The consumer substation with MV metering	B26
	5.1 Definition	B26
	5.2 Functions of the substation with MV metering	B26
	5.3 Choice of MV equipment	B28
6	Choice and use of MV equipment and MV/LV transformer	B29
	6.1 Choice of MV equipment.....	B29
	6.2 Instructions for use of MV equipment	B30
	6.3 Choice of MV/LV transformer.....	B31
	6.4 Ventilation in MV Substations	B34
7	Substation including generators and parallel operation of transformers	B37
	7.1 Generators in stand-alone operation, not working in parallel with the supply network ..	B37
	7.2 Generators operating in parallel with the utility supply network.....	B37
	7.3 Parallel operation of transformers.....	B39
8	Types and constitution of MV/LV distribution substations	B40
	8.1 Different types of substations	B40
	8.2 Indoor substation	B40
	8.3 Outdoor substations.....	B42

1 Power supply at medium voltage

The term "medium voltage" is commonly used for distribution systems with voltages above 1 kV and generally applied up to and including 52 kV^[1]. For technical and economic reasons, the service voltage of medium voltage distribution networks rarely exceeds 35 kV.

In this chapter, networks which operate at 1000 V or less are referred to as low voltage (LV) networks.

The connection of an electrical installation to a MV utility distribution network is always realized by means of a dedicated MV substation usually designed "Main substation". Depending on its size and specific criteria mainly related to the loads (Rated voltage, number, power, location, etc...), the installation may include additional substations designed "Secondary substations". The locations of these substations are carefully selected in order to optimize the budget dedicated to MV and LV power cables. They are supplied from the main substation through the internal MV distribution.

Generally, most of the loads are supplied in low voltage by means of MV/LV step down transformers. Large loads such as asynchronous motors above around 1MW are supplied in MV. Only LV loads are considered in this electrical guide.

MV/LV step down power transformers are indifferently located either in the main substation or in the secondary substations. Small installations may only include a single MV/LV transformer installed in the main substation in most of the cases.

A main substation includes five basic functions:

Function 1: Connection to the MV utility network

Function 2: General protection of the installation

Function 3: Supply and protection of MV/LV power transformers located in the substation

Function 4: Supply and protection of the internal MV distribution

Function 5: Metering.

For the installations including a single MV/LV power transformer the general protection and the protection of the transformer are merged.

The metering can be performed either at MV level or at LV level. It is authorized at LV level for any installation including a single MV/LV transformer, provided that the rated power of the transformer remains below the limit fixed by the local utility supplying the installation.

In addition to the functional requirements the construction of both main and secondary substations shall comply with the local standards and rules dedicated to the protection of persons. IEC recommendations should also be taken into consideration in all circumstances.

1.1 Main requirements for power supply at Medium Voltage and typical architectures

The characteristics of electrical equipment (switchgears, transformers, etc...) installed in the substations are fixed by the rated values of both voltage and current specified for the distribution network supplying the installation:

- U_r , rated voltage, rms value, kV
- U_d , rated power frequency withstand voltage, rms value, kV during 1mn
- U_p : rated lightning impulse withstand voltage, peak value, kV
- U_n , service voltage, rms value, kV

As the rated voltage U_r indicates the maximum value of the "highest system voltage" of networks for which the equipment may be used, the service voltage U_n really existing in the network, including its possible variations shall remain below the rated voltage.

- Rated normal current I_r , rms value, A
- Rated short-time withstand current I_k , rms value, kA
- Rated peak withstand current I_p , peak value, kA.

[1] According to the IEC there is no clear boundary between medium and high voltage. Local and historical factors play a part, and limits are usually between 30 and 100 kV (see IEC 601-01-28). The publication IEC 62271-1 "High-voltage switchgear and controlgear; common specifications" incorporates a note in its scope: "For the use of this standard, high voltage (see IEC 601-01-27) is the rated voltage above 1000 V. However, the term medium voltage (see IEC 601-01-28) is commonly used for distribution systems with voltages above 1 kV and generally applied up to and including 52 kV."

1 Power supply at medium voltage

Considering the previous requirements and basic usages, four typical architectures can be defined for an electrical installation connected to a MV utility distribution network:

Fig. B1: single MV/LV power transformer with metering at LV level

Fig. B2: single MV/LV power transformer with metering at MV level

Fig. B3: several MV/LV transformers, all located in the main substation

Fig. B4: several secondary substations supplied by an internal MV distribution. Most of MV/LV transformers are located in secondary substations. Some of them when required are installed in the main substation

The functional and safety requirements defined above are detailed in this chapter, in the following sub-clauses:

- 1.2 to 1.4: Voltages and currents according to IEC Standards, different types of MV power supply, practical issues concerning MV distribution networks
- 2.1 to 2.2: Procedure for the establishment of a new substation
- 3.1 to 3.4: Protection against electrical hazards, faults and mis-operations
- 4.1 to 4.2: Consumer substation with LV metering
- 5.1 to 5.2: Consumer substation with MV metering
- 6.1 to 6.4: Choose and use MV equipment and MV/LV transformers
- 7.1 to 7.3: Substation including generators and parallel operation of transformers
- 8.1 to 8.3: Types and constitution of MV/LV distribution substations.

The methodology of selection of an architecture for a MV/LV electrical installation is detailed in **chapter D**.

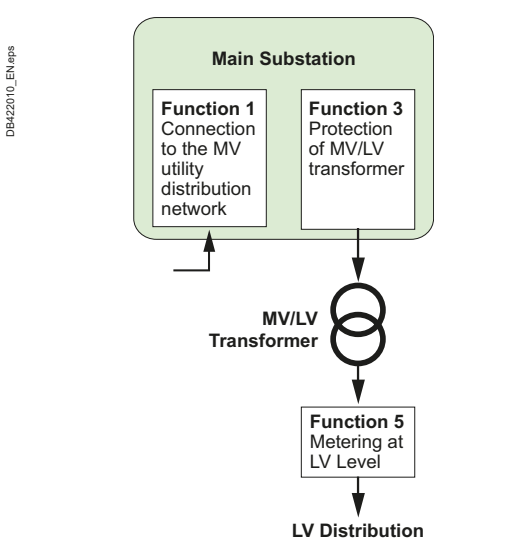


Fig. B1 Installation including a single MV/LV power transformer with metering at LV level

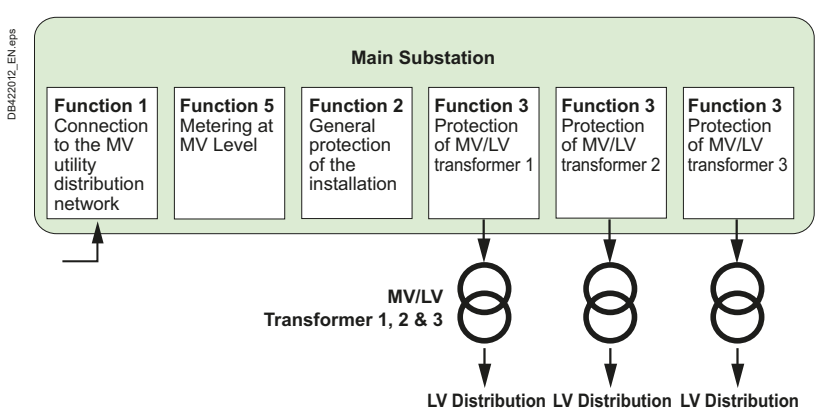


Fig. B3 Installation including several MV/LV transformers, all located in the main substation

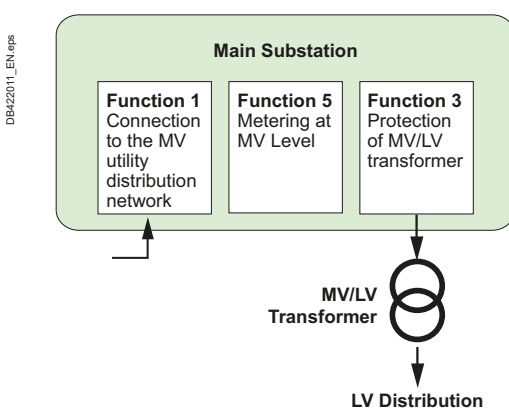


Fig. B2 Installation including a single MV/LV power transformer with metering at MV level

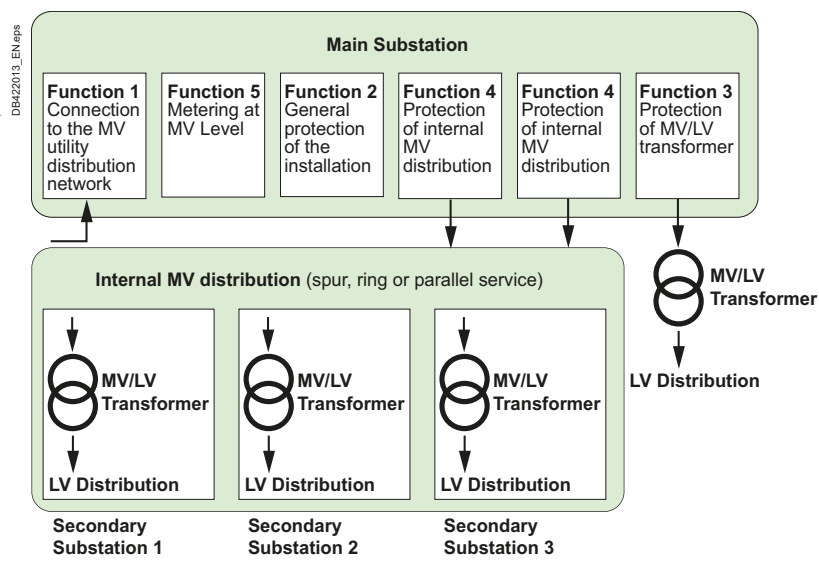


Fig. B4 Installation including several secondary substations supplied by an internal MV distribution

1 Power supply at medium voltage

1.2 Medium voltages and current values according to IEC Standards

1.2.1 Rated voltage values according to IEC 60071-1 (Insulation co-ordination – Part 1: Definitions, principles and rules) (see Fig. B5)

- **Ur**, rated voltage, rms value, kV: this is the maximum rms value of voltage that the equipment can withstand permanently. 24 kV rms for example.
- **Ud**, rated power frequency withstand voltage, rms value, kV during 1 mn: defines the level of rms over-voltages that the equipment may withstand during 1 minute. 50 kV rms for example.
- **Up**, rated lightning impulse withstand voltage, peak value, kV: define the level of lightning over-voltages that the equipment may withstand. 125 kV peak for example.
- **Un**, service voltage, rms value, kV: is the voltage at which the MV utility distribution network is operated. For example, some networks are operated at Un 20 kV. In this case, switchgear of at least 24 kV rated voltage shall be installed.

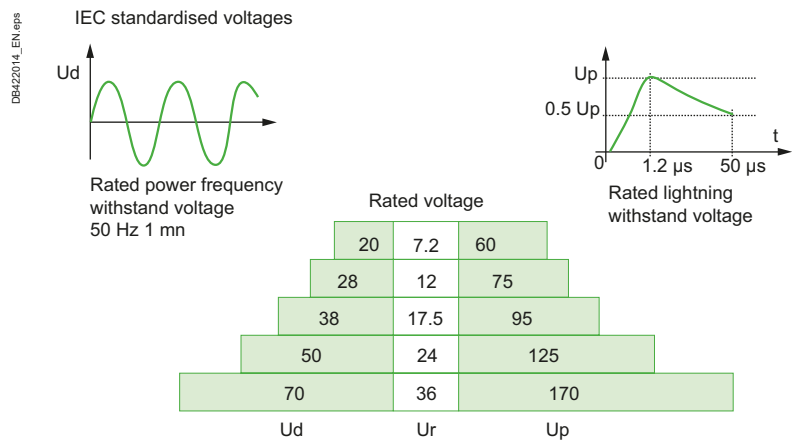


Fig. B5 Example of standard values Ur, Ud, Up (kV)

1.2.2 Rated current values according to IEC 62271-1 (High-voltage switchgear and controlgear - Part 1: Common specifications)

- **Ir**, rated normal current, rms value, A: this is the rms value of current that equipment may withstand permanently, without exceeding the temperature rise allowed in the standards. 630 A rms for example.
- **Ik**, rated short-time withstand current, rms value, kA: this is the rms value of the short circuit current that the equipment can carry during a specific time. It is defined in kA for generally 1 s, and sometimes 3 s. It is used to define the thermal withstand of the equipment 12 kA rms 1s for example.
- **Ip**, rated peak withstand current, peak value, kA: this is the peak value of the short circuit current that the equipment may withstand. It is used to define the electro-dynamic withstand of the equipment, 30 kA peak for example.

1 Power supply at medium voltage

1.3 Different types of MV power supply

The following methods may be used for the connection of an electrical installation to a MV utility distribution network.

1.3.1 Connection to an MV radial network: Single-line service

The substation is supplied by a tee-off from the MV radial network (overhead line or underground cable), also known as a spur network.

This method provides only one supply for loads (see **Fig. B6 A and B**). It is widely used for installations including a single MV/LV transformer with LV metering. It can also be used without any restriction for installations with MV metering including either several MV/LV transformers or even an internal MV distribution network.

The connection is made by means of a single load break switch associated to a earthing switch dedicated to overhead line or underground cable grounding.

This principle can be the first step of the two other methods of connection (ring main and dual parallel feeders), the upgrading of the substation being generally performed during an extension of the installation or required by the adjunction of loads asking a higher level of supply continuity.

Generally, the pole-mounted transformers in rural areas are connected to the over-head lines according to this principle without load break switch nor fuses. Protection of the line and associated switching devices are located in the remote substations supplying the over-head distribution network.

1.3.2 Connection to an MV loop: Ring-main service

The substation is connected to a loop (see **Fig. B6 C**) of the medium voltage distribution network. The line current passes through the substation which gives the possibility to supply the substation by two different ways.

With this arrangement, the user benefits of a reliable power supply based on two redundant MV feeders.

The connection is made by means of two independent load break switches, each associated to an earthing switch for underground cables earthing.

This method is mainly used for the underground MV distribution networks found in urban areas.

1.3.3 Connection to two dual MV cables: Parallel feeders service

Two parallel underground cables are used to supply the substation. Each cable is connected to the substation by means of a load-break switch. (see **Fig. B6 D**).

As mentioned for single and ring main service cable grounding is performed by means of earthing switches associated to the load break switches.

The two load break switches are interlocked, meaning that only one load break switch is closed at a time.

This principle gives the possibility to supply the substation by two independent sources giving a full redundancy.

In the event of the loss of supply, the load-break switch supplying the installation before the loss of supply must be open and the second must be closed.

This sequence can be performed either manually or automatically.

This method is used to supply very sensitive installation such as hospitals for example. It is also often used for densely-populated urban areas supplied by underground cables.

B - Connection to the MV utility distribution network

1 Power supply at medium voltage

B6

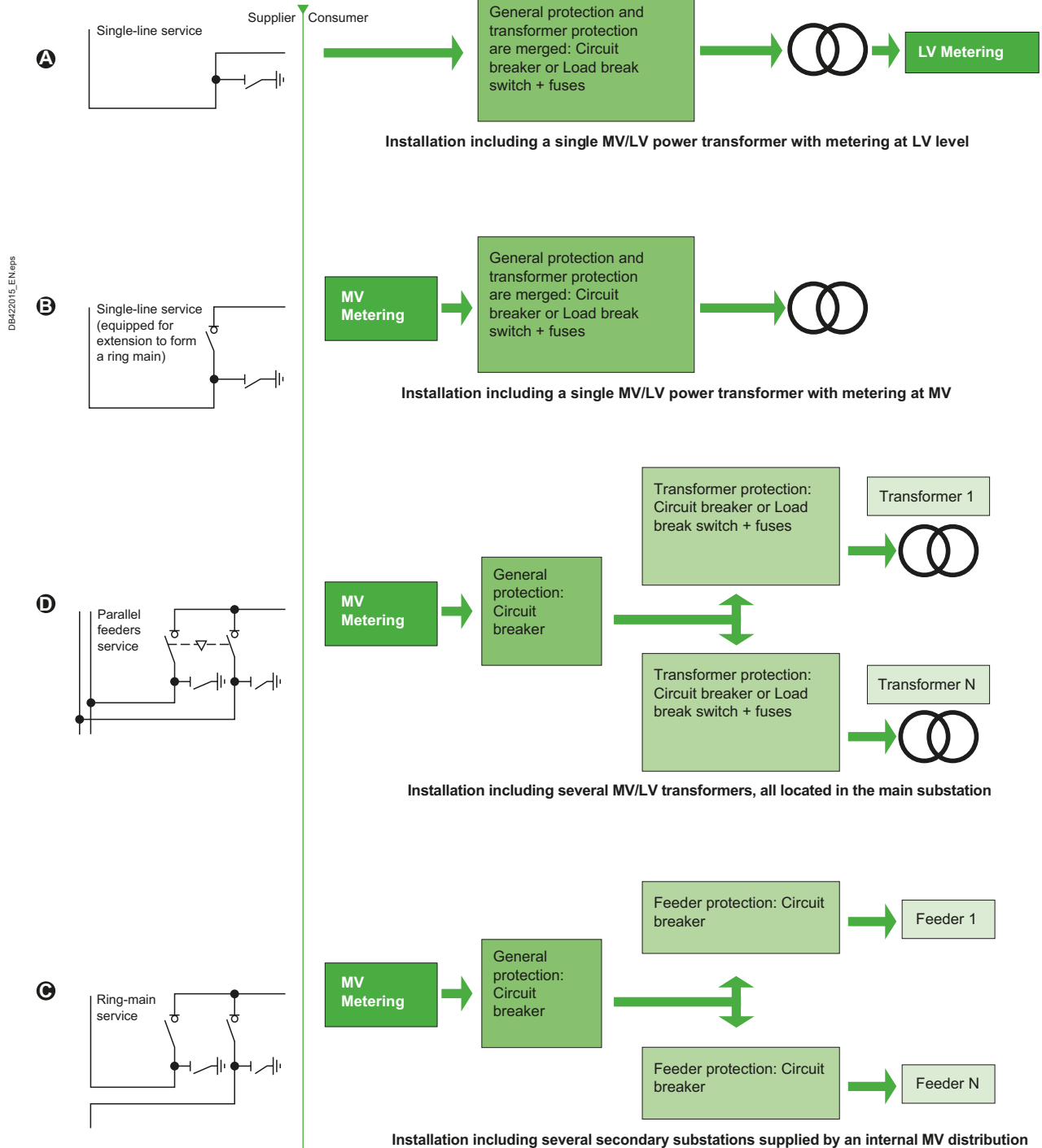


Fig. B6 A: Single line service. B: Single line service with provision for extension to ring main or parallel feeder service. C: Ring main service. D: parallel feeder service

1 Power supply at medium voltage

1.4 Some practical issues concerning MV distribution networks

1.4.1 Overhead networks

Weather conditions such as wind may bring overhead wires into contact and cause phase to phase short-circuits.

Over voltages due to lightning strokes may generate flash-over across ceramic or glass insulators and cause phase to earth faults

Temporary contacts of vegetation such as trees with live overhead conductors may also generate phase to earth faults.

Most of these faults are temporary. They disappear naturally with the interruption of the voltage. This means that the supply can be restored after a short delay following the tripping. This delay is usually named "dead time".

Hence the sequence of fault clearing and voltage restoration in an overhead network is as follows:

- Fault detection by phase to phase or phase to earth protection
- Circuit breaker opening, the faulty over-head line is de-energized
- Dead time
- Circuit breaker reclosing. Following the reclosing two situations are possible:
 - The fault has been cleared by the interruption of the voltage, the reclosing is successful
 - The line is still faulty, a new tripping is initiated followed again by a reclosing sequence.
- Several sequences of tripping-reclosing may be activated depending on the rules of operation of the network adopted by the utility
- If after the execution of the preselected number of reclosing sequences the fault is still present, the circuit breaker is automatically locked and consequently the faulty part of the network remains out of service until the fault is localized and eliminated.

As such, it is possible to improve significantly the service continuity of overhead networks by using automatic reclosing facilities. Generally a reclosing circuit breaker is associated to each overhead line.

1.4.2 Underground networks

Cable Faults on underground MV cables may have several causes such as:

- Poor quality of cable laying, absence of mechanical protection
- Bad quality of cable terminations confection
- Damages caused by excavators or tools such as pneumatic drills
- Over voltages generated by lightning strokes occurring on overhead line connected to underground cables. The over voltages can be amplified at the levels of the junctions between overhead lines and underground cables causing the destruction of the cable terminations. Lightning arresters, are often installed at these locations to limit the risks of damages.

The experience shows that the rate of fault occurring on underground cables is lower than the one registered for overhead lines. But faults on underground cables are invariably permanent and take longer time to locate and repair.

A loop architecture (see Fig. B10) correctly instrumented with fault detectors and motorized load break switches allow within a short period of time to identify a faulty cable, to disconnect it and to restore the supply to the whole substations included in the loop.

These procedures of faults detection, cables disconnection and supply restoration can be automatically performed in less than one minute by dedicated functions commonly integrated in remote control and monitoring systems of MV networks.

1.4.3 Remote control and monitoring for MV networks (see Fig. B7)

Remote control and monitoring of MV feeders make it possible to reduce loss of supply resulting from cable faults by supporting fast and effective loop reconfiguration.

This facility relies on motorized switches associated with fault detectors on a number of substations in the loop and controlled by remote control units.

All stations containing this equipment can have their supply restored remotely, whereas other stations will require additional manual operations.

The use of centralised remote control and monitoring based on SCADA (Supervisory Control And Data Acquisition) systems and recent developments in digital communication technology is increasingly common in countries where the complexity associated with highly interconnected networks justifies the investment required.



Fig. B7 Supervisory Control And Data Acquisition System SCADA

1 Power supply at medium voltage

1.4.4 Values of earth fault currents in MV networks

(see Fig. B8 and Fig. B9)

The values of earth fault currents in MV distribution networks depend on the MV neutral earthing system. These values must be limited to reduce their effects, mainly:

- Damages to equipment
- Temporary over voltages
- Transient over voltages
- Touch and step voltages.

The neutral of an MV network can be earthed by five different methods, according to type (resistive, inductive) and the value (zero to infinity) of the impedance Z_n connected between the neutral and the earth:

- $Z_n = \infty$ isolated neutral, no intentional neutral earthing connection
- Z_n is related to a resistance with a fairly high value,
- Z_n is related to a reactance, with a generally low value,
- Z_n is related to a compensation reactance, designed to compensate the capacitance of the network
- $Z_n = 0$: the neutral is solidly earthed.

	Methods of Neutral Earthing				
	Isolated	Resistance	Reactance	Compensated	Solid
Damages	Very Low	Low	Low	Very Low	Very high
Temporary over voltages	High	Medium	Medium	Medium	Low
Transient over voltages	High	Low	High	High	Low
Touch and step voltages	Very Low	Low	Low	Low	High

Fig. B8 Effects of the phase to earth fault current

The fault current I_{k1} is the sum of two components:

- The neutral current through the impedance Z_n
- The capacitive current through the phase to earth capacitors.

When Z_n is a reactance these two currents are opposite, which means that the reactance compensate the capacitive current. If the compensation is perfect, the fault current value is zero.

DB42017.eps

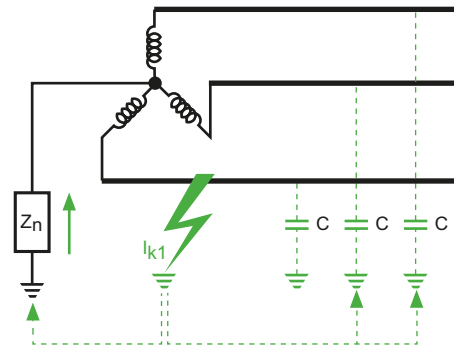


Fig. B9 Circulation of the phase to earth fault current

1 Power supply at medium voltage

1.4.5 Medium voltage loop (see Fig. B10)

A medium voltage loop is generally supplied from two separate primary substations. It supplies secondary MV/LV substations dedicated to the LV public distribution and private electrical installations.

The MV/LV secondary substations and those dedicated to the connection of private electrical installations are connected in series by means of underground cables. Two load break switches are used for the connection of each secondary substation. The loop is normally open, all the load break switches are closed except one.

In case of fault between A and B, the breaker C trips clearing the fault. The two substations S1 and S2 are de-energized. The restoration of the supply to all substations is then realized as follow:

- 1 - Isolation of the faulty cable by opening load break switches A and B
- 2 - Closing open point D
- 3 - Reclosing circuit breaker C. The open point is now between S1 and S2.

This sequence of faulty cable disconnection followed by the restoration of the supply can be executed either manually by the operators of the MV network or automatically by means of dedicated functions integrated in remote control and monitoring systems of MV networks.

Manual operations are generally long whereas automatic supply restoration can be executed within less than one minute by the remote control system. These automatism now available in any control system require a suitable instrumentation of the loop:

- Fault detectors at both ends of the underground cables
- Motorized load break switches
- Remote Terminal Unit (RTU) in each secondary substation. The RTU performs:
 - The monitoring of the fault detectors and load break switches
 - Local automatism
 - The command of load break switches
 - The communication with the remote control and monitoring center
- DC auxiliary supply in every substation.

As described above, most of the loops are historically equipped with load break switches and protected at each end only by circuit breakers located in the HV/ MV primary substations. In case of fault, all the customers supplied by a faulty feeder are disconnected. But in fact the customers upstream from the fault could have not been disconnected.

The addition of circuit breakers, adequately located and associated with appropriate protection relays may reduce the number of customers disconnected in case of fault.

As an example, a loop including two additional circuit breakers is divided in four independent sections. Assume the open point located between the two additional circuit breakers. In case of fault in the section delimited by these two circuit breakers only a part of the secondary substations of the section will be disconnected, all the other remaining energized.

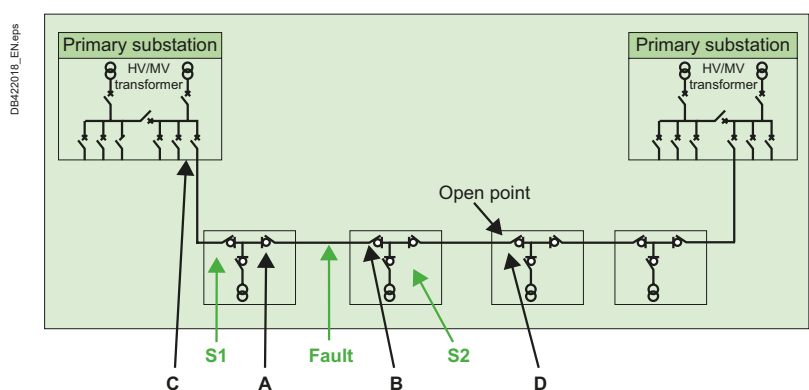


Fig. B10 Open loop configuration and operation

2 Procedure for the establishment of a new substation

Large consumers of electricity are always fed by a medium voltage supply.

On LV systems operating at 120/208 V (3-phases 4-wires), a load of 50 kVA may be considered as "large", while on a 230/400 V (3-phases 4-wires) system this limit is generally above 100 kVA. These two systems of LV distribution are widely used in most of the parts of the world. See chapter A §2.1 "Definition of voltage ranges".

The IEC recommends a "world" standard low voltage system of 230/400 V for 3-phases 4-wires. This is a compromise which will allow the existing systems operated at either 220/380 V or 240/415 V, or close to these values, to comply simply with the proposed standard by just adjusting the off load tap changers of the MV/LV distribution transformers.

The choice of the most appropriate level of supply of a new electrical installation is under the responsibility of the utility operating the network to which the installation is supposed to be connected.

The decision is mainly based on two criteria:

- The distance to the primary substation that will feed the installation
- The total power required by the installation.

Other criteria such as the rate of availability of the electricity supply are also taken into account.

There are two possibilities for the construction of a substation dedicated to the supply of a new electrical installation:

1 - The utility builds the substation according to its own specifications, close to the consumer's premises. The MV/LV transformer(s) however, remain located inside the installation, close to the loads.

Depending on local rules the MV/LV transformer(s) may belong or not to the utility, they may be installed or not by the owner of the installation, the utility has or not unrestricted access to their locations

2 - The owner of the electrical installation builds and equips the substation inside his premises.

In most of the cases the utility must at least have unrestricted access to the metering and to the part of the substation ensuring the connection of the installation to the MV utility network. The utility may require a separate room for the equipment dedicated to these two functions.

The following chapters only refer to the construction of the substation by the owner of the electrical installation.

2.1 Preliminary information

In most of the cases the project of the construction of a new substation must be submitted before any further detailed studies to the approval of the utility operating the MV network that will feed the substation. The list of information to provide for this approval may be the result of preliminary discussions with the utility. Among all information, the following are generally required:

2.1.1 Maximum anticipated power (kVA) demand

The method of evaluation of this parameter is detailed in Chapter A, it must take into account the future additional loads. According to chapter A, two factors associated to the loads are used in the proposed method:

- The factor of maximum utilization (k_u)
- The diversity factor (k_s).

2.1.2 Layout and arrangement drawings of the proposed substation

The following information may be required:

- Situation of the substation with regard to traffic lane
- Location of the substation inside the installation
- Dispositions foreseen for the unrestricted access of the utility operating staff
- Arrangement drawings showing clearly the location of the electrical equipment (MV Switchboard, transformers, Metering panel,...)
- Routing of MV cables
- Single line diagram and type of protections against phase to phase and phase to earth faults
- Main characteristics of electrical equipment
- Solution foreseen for the compensation of the reactive energy
- Principle of the earthing system
- Presence in the installation of a power generator operated in parallel with the MV network
- Etc.

2 Procedure for the establishment of a new substation

2.1.3 Degree of supply continuity required

The consumer must estimate the consequences of a failure of supply in terms of:

- Safety of the persons
- Impact on the environment
- Safety of the installation
- Loss of production.

He shall indicate to the utility the acceptable frequency of the interruptions of the electricity and their durations.

2.2 Information and requirements provided by the utility

Based on the information provided by the consumer, the utility must provide his proposition, his commitment and his own requirements concerning the connection of the substation:

- Level of voltage
- Supply by overhead line
- Supply by underground cables
- Single-line service, ring type supply, parallel feeders, etc.
- Rated values concerning the voltage
- Rated value concerning the current
- Details concerning the applicable tariff and the billing of the electrical energy
- Comments on drawings and information provided by the consumer
- Specific requirements applicable to the substation.

The detailed studies of the substation must take into account all these parameters and requirements.

2.3 Commissioning, testing, energizing

When required by the local authority, commissioning tests and checking must be successfully completed to get the authorization to energize a new installation.

The following tests and checking are generally mandatory and applicable to the whole installation:

- Verification that the main substation complies with all the requirements expressed by the utility
- Measurement of earth-electrodes resistances
- Electrical continuity of all equipotential and bonding conductors
- Inspection and functional testing of all MV components
- Dielectric test of switchgears and transformers
- Inspection and testing of the LV parts of the installation
- Mechanical and electrical interlocks checking
- Protective-relays checking
- Other additional tests and checking may be required.

As soon as the conformity official document is issued, the utility proceeds with the energizing of the installation.

3 Protection against electrical hazards, faults and mis-operations in electrical installations

The subject of protection in the industry and electrical installations is vast. It covers many aspects:

- Protection of the persons and animals against electrical shocks
- Protection of the equipment and components against the stresses generated by short-circuits, lightning surges, power-system instability, and other electrical perturbations
- Protection of the property and equipment against damages and destructions
- Protection against the production losses
- Protection of the workers, the surrounding population and the environment against fire, explosions, toxic gases, etc.
- Protection of the operators and of the electrical equipment from the consequences of incorrect operations. This means that the switching devices (Load break switches, disconnectors, earthing switches) must be operated in the right order. Suitable Interlocking ensures strict compliance with the correct operating sequences.

Four aspects of the protection are detailed in the scope of this guide:

- Protection against electrical shocks
- Protection of the transformers against external constraints and internal faults
- Improvement of MV/LV transformer protection with circuit breaker associated to self powered relay
- Protection of the operators against the consequences of incorrect operations by appropriate interlocks.

3.1 General principle of protection against electrical shocks in electrical installations

Protective measures against electric shocks are based on two well known dangers:

- **Direct contact:** contact with an active conductor, i.e. which is live with respect to the earth in normal circumstances. (see Fig. B11).
- **Indirect contact:** contact with a conductive part of an apparatus which is normally dead and earthed, but which has become live due to an internal insulation failure. (see Fig. B12).

Touching the part with hand would cause a current to pass through the hand and both feet of the exposed person. The value of the current passing through the human body depends on:

- The level of the touch voltage generated by the fault current injected in the earth electrode (see Fig. B12)
- The resistance of the human body
- The value of additional resistances like shoes.

In Fig. B13, the green curve shows the variation of the earth surface potential along the ground: it is the highest at the point where the fault current enters the ground, and declines with the distance. Therefore, the value of the touch voltage U_t is generally lower than the earth potential rise U_e .

On the left side, it shows the earth potential evolution without potential grading earth electrodes. On the right side, it describes how buried potential grading earth electrodes made of naked copper (S1, S2, Sn..) contribute to the reduction of the contact voltages (U_t , U_s).

A third type of shock hazard is also shown in Fig. B13, the "step- voltage" hazard (U_s): the shock current enters by one foot and leaves by the other. This hazard exists in the proximity of MV and LV earth electrodes which are passing earth-fault currents. It is due to the potential gradients on the surface of the ground. Animals with a relatively long front-to-hind legs span are particularly sensitive to step-voltage hazards.

It clearly appears that the higher is the potential gradient without control (U_e), the higher are the levels of both touch voltage (U_t) and step voltage (U_s).

Any presence of bonding conductors between all the metallic parts embedding concrete reinforcement contributes significantly to the reduction of contact voltages (touch, step). In addition, surrounding the MV installation with any equipotential loop of buried naked copper contributes to a wider equipotential area.

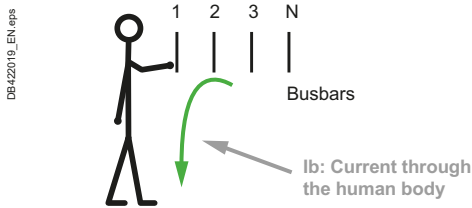
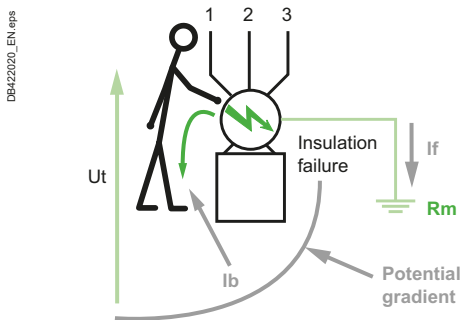


Fig. B11 Direct contact

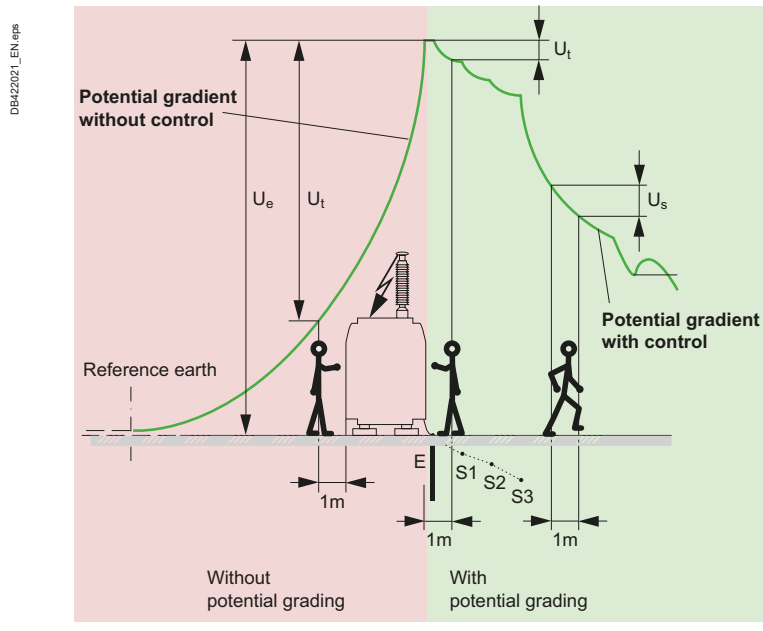


- U_t : Touch voltage
- $U_t \leq U_e$
- U_e : Earth potential rise
- $U_e = R_m \times I_f$
- I_b : Current through the human body
- $I_b = U_t/R_b$
- R_b : Resistance of the human body
- I_f : Earth Fault current
- R_m : Resistance of the earth electrode

Note: The touch voltage U_t is lower than the earth potential rise U_e . U_t depends on the potential gradient on the surface of the ground.

Fig. B12 Indirect contact

3 Protection against electrical hazards, faults and mis-operations in electrical installations



Ue: Earth potential rise. **Ut:** Prospective touch voltage.
E: Earth electrode. **S1,S2,S3:** Potential grading earth electrodes (e.g. ring earth electrodes), connected to the earth electrode E
Us: Prospective step voltage.

Fig. B13 Potential gradient control - EN50522 - Earthing of power installations exceeding 1 kV a.c.

3.1.1 Direct-contact protection or basic protection

There are four main principles of protection against direct contact hazards:

- By containing all live parts in housings made of insulating material or in metallic earthed cubicles.
- For MV switchgear, the IEC standard 62271-200 (Prefabricated Metal Enclosed switchgear and controlgear for voltages up to 52 kV) specifies a minimum Protection Index (IP coding) of IP2X to ensure the direct-contact protection. Furthermore, the metallic cubicles has to demonstrate an electrical continuity between all inside and outside metallic parts.
- By placing live parts out of reach. This principle is used in Air Insulated Substations "AIS" (see Fig. B15)
- By installations of barriers also used in AIS substations (see Fig. B14)
- By insulation. The best example of protection by insulation is the electrical LV and HV cables.

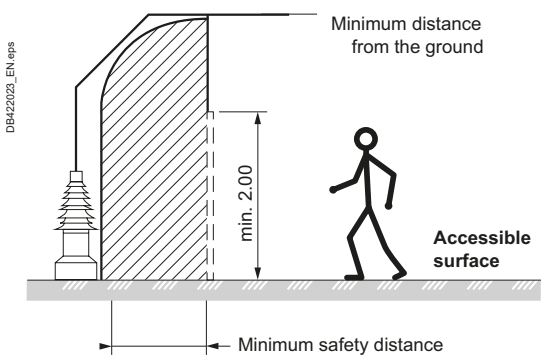


Fig. B14 Protection by installation of barriers. The safety distances are fixed by IEC 61936

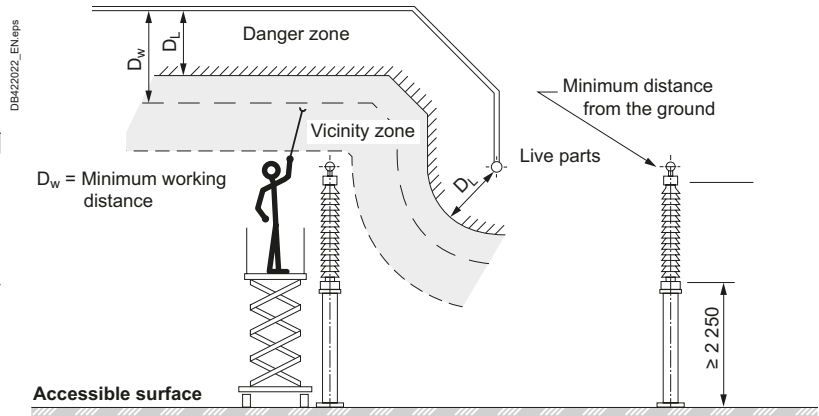


Fig. B15 Protection by placing live parts out of reach. The safety distances are fixed by IEC 61936

3 Protection against electrical hazards, faults and mis-operations in electrical installations

B14

3.1.2 Indirect-contact protection or fault protection

As described above, a person touching the metal enclosure or the frame of an electrical apparatus affected by an internal failure of insulation is subject to an indirect contact.

Extensive studies have demonstrated that a current lower than 30 mA passing through the human body can be considered as not dangerous. It corresponds to a touch voltage of about 50 V.

This means that the operation of installations may continue in presence of any phase to earth fault if the touch voltages can be maintained below 50 V. In all other situations where the expected touch voltages are above 50 V the interruption of the supply is mandatory. The higher the expected touch voltages are, the lower the interruption time must be. The maximum admissible interruption times, function of the expected touch voltages are specified by the IEC 60364 and IEC 61936 for LV and HV systems respectively.

Case of fault on L.V. system

Only the isolated neutral system (IT) allows to maintain touch voltages below 50 V and does not require the interruption of the supply in presence of phase to earth faults. Other two neutral systems (TT and TN) are always subjected to expected touch voltages above 50 V. In these cases the interruption of the voltage is mandatory. It is ensured within the time specified by the IEC 60364, either by the circuit breakers or the fuses protecting the electrical circuits. For more information concerning indirect contact in LV system, refer to chapter F.

Indirect-contact hazard in the case of a MV fault

In MV electrical systems, the expected touch voltages may reach values requiring interruption of the supply within much shorter times than the quickest opening time of the breakers. The principle of protection used for the LV systems cannot be applied as such for MV systems.

One possible solution for the protection of the persons is to create equipotential systems by means of bonding conductors interconnecting all the metallic parts of the installation: enclosures of switchgears, frames of electrical machines, steel structures, metallic floor pipes, etc. This disposition allows to maintain the touch voltages below the dangerous limit.

A more sophisticated approach concerning the protection of persons against indirect contact in MV and HV installations is developed in IEC 61936 and EN 50522. The method developed in these standards authorizes higher touch voltage limits justified by higher values of the human body resistance and additional resistances such as shoes and layer of crushed rock.

3.2 Protection of transformer and circuits

The electrical equipment and circuits in a substation must be protected in order to limit the damages due to abnormal currents and over voltages.

All equipment installed in a power electrical system have standardized ratings for short-time withstand current and short duration power frequency voltage.

The role of the protections is to ensure that these withstand limits can never be exceeded, therefore clearing the faults as fast as possible.

In addition to this first requirement a system of protection must be selective.

Selectivity means that any fault must be cleared by the device of current interruption (circuit breaker or fuses) being the nearest to the fault, even if the fault is detected by other protections associated with other interruption devices.

As an example for a short circuit occurring on the secondary side of a power transformer, only the circuit breaker installed on the secondary must trip.

The circuit breaker installed on the primary side must remain closed.

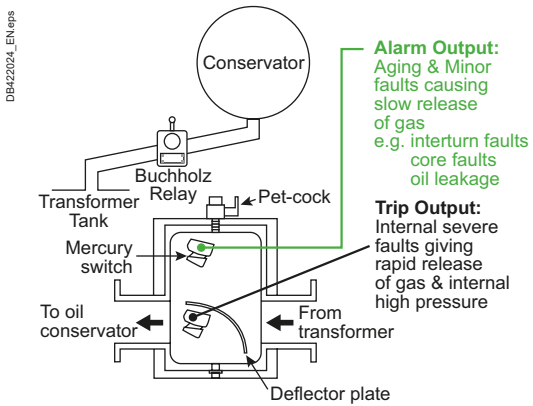
For a transformer protected with MV fuses, the fuses must not blow.

They are typically two main devices able to interrupt fault currents, circuit breakers and fuses :

■ The circuit breakers must be associated with a protection relay having three main functions:

- Measurement of the currents
- Detection of the faults
- Emission of a tripping order to the breaker
- The fuses blow under certain fault conditions.

3 Protection against electrical hazards, faults and mis-operations in electrical installations



(a) Functioning principle



(b) Transformer with conservator

Fig. B16 Breathing transformer protected by buchholz

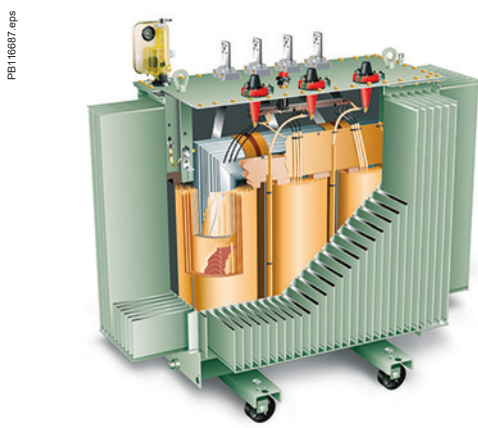


Fig. B17 Integral filled transformer

3.2.1 Transformer protection

Stresses generated by the supply

Two types of over voltages may stress and even destroy a transformer:

- The lightning over voltages due to lightning stroke falling on or near an overhead line supplying the installation where the transformer is installed
- The switching over voltages generated by the opening of a circuit breaker or a load break switch for instance.

Depending of the application, protection against these two types of voltage surges may be necessary and are often ensured by means of Z_nO surge arrestors preferably connected on the MV bushing of the transformer.

Stresses due to the load

A transformer overload is always due to an increase of the apparent power demand (kVA) of the installation. This increase of the demand can be the consequence of either a progressive adjunction of loads or an extension of the installation itself. The effect of any overload is an increase of the temperature of oil and windings of the transformer with a reduction of its life time.

The protection of a transformer against the overloads is performed by a dedicated protection usually called thermal overload relay. This type of protection simulates the temperature of the transformer's windings. The simulation is based on the measure of the current and on the thermal time constant of the transformer. Some relays are able to take into account the effect of harmonics of the current due to non-linear loads such as rectifiers, computers, variable speed drives etc. This type of relay is also able to evaluate the remaining time before the emission of the tripping order and the time delay before re-energizing the transformer. In addition, oil-filled transformers are equipped with thermostats controlling the temperature of the oil. Dry-type transformers use heat sensors embedded in the hottest part of the windings insulation. Each of these devices (thermal relay, thermostat, heat sensors) generally provides two levels of detection:

- A low level used to generate an alarm to advise the maintenance staff,
- A high level to de-energize the transformer.

Internal faults in oil filled transformers

In oil filled transformers, internal faults may be classified as follow:

- Faults generating production of gasses, mainly:
 - Micro arcs resulting from incipient faults in the winding insulation
 - Slow degradation of insulation materials
 - Inter turns short circuit
- Faults generating internal over pressures with simultaneously high level of line over currents:
 - Phase to earth short circuit
 - Phase to Phase short circuit.

These faults may be the consequence of external lightning or switching over voltage. Depending on the type of the transformer, there are two kinds of devices able to detect internal faults affecting an oil filled transformer.

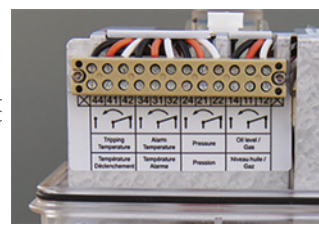
- The Buchholz dedicated to the transformers equipped with an air breathing conservator (see Fig. B16 (a))
- The buchholz is installed on the pipe connecting the tank of he transformer to the conservator (see Fig. B16 (b)). It traps the slow emissions of gasses and detect the flow back of oil due to the internal over pressures
- The DGPT (Detection of Gas, Pressure and Temperature, see Fig. B18) for the integral filled transformers (see Fig. B17). This type of transformer is manufactured up to around 10 MVA. The DGPT as the buchholz detects the emissions of gasses and the internal over pressures. In addition it monitors the temperature of the oil.

Concerning the monitoring of gas and temperature the buchholz and the DGPT provide two levels of detection:

- A low level used to generate an alarm to advise the maintenance staff,
 - A high level to trip the switching device installed on the primary side of the transformer (circuit breaker or load break switch associated with fuses).
- In addition, both the buchholz and the DGPT are suitable for oil leakages detection.



(a) Transformer protection relay (DGPT)



(b) Contacts of the DGPT (cover removed)

Fig. B18 DGPT (Detection of Gas, Pressure and Temperature) protection relay for integral filled transformers

3 Protection against electrical hazards, faults and mis-operations in electrical installations

B16

PB 116688.eps



Fig. B19 Dry type transformer

Thermal_relay_(Ziehl).eps



Fig. B20 Thermal relay for protection of dry type transformer (Ziehl)

DB422828_EN.eps

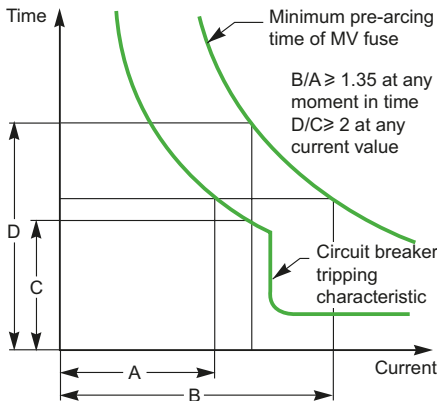


Fig. B21 Selectivity between MV fuse operation and LV circuit breaker tripping, for transformer protection

DB422029_EN.eps

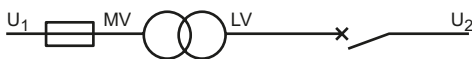


Fig. B22 MV fuse and LV circuit breaker configuration

Overloads and internal faults in dry type transformers

(see Fig. B19 and Fig. B20)

The dry type transformers are protected against over-heating due to possible downstream overloads by a dedicated relay monitoring thermal sensors embedded in the windings of the transformer (see Fig. B20).

The internal faults, mainly inter turns and phase to earth short circuits occurring inside a dry type transformers are cleared either by the circuit breaker or the fuses installed on the primary side of the transformer. The tripping of the circuit breakers when used is ordered by the phase to phase and phase to earth over current protections.

Inter turns faults need a dedicated attention:

- They generally generate moderate line over currents. As an example when 5 % of a HV winding are short circuited the line current of the transformer does not exceed $2 I_n$, for a short circuit affecting 10 % of the winding the line current is limited around $3 I_n$.

- Fuses are not appropriate to clear properly such currents

- Dry type transformers are not equipped with additional protection devices such as DGPT dedicated to internal faults detection.

Hence, internal faults generating low level of line over current may not be safely cleared by fuses. Protection by means of over current relay with adequate characteristic and settings is preferred (Schneider Electric VIP relay range for example).

Selectivity between the protective devices upstream and downstream of the transformer

It is a common practice to ensure the selectivity between the MV circuit breaker or fuses installed on the primary side of a transformer and the LV circuit breaker.

The characteristics of the protection ordering the tripping or the MV circuit breaker or the operating curves of the fuses when used must be such as in case of downstream fault the LV circuit breaker only trips. The MV circuit breaker must remain closed or the fuse must not blow.

The tripping curves of MV fuses, MV protection and LV circuit breakers are given by graphs giving the operating time as a function of the current.

The curves are in general inverse-time type. LV circuit breakers have an abrupt discontinuity which defines the limit of the instantaneous action.

Typical curves are shown in Fig. B21.

Selectivity between LV circuit breaker and MV fuses

(see Fig. B21 and Fig. B22)

- All parts of the MV fuse curve must be above and to the right of the LV CB curve.

- In order to leave the fuses unaffected (i.e. undamaged), the two following conditions must be satisfied:

- All parts of the minimum pre-arcing fuse curve must be shifted to the right of the LV CB curve by a factor of 1.35 or more.

- Example: where, at time T, the CB curve passes through a point corresponding to 100 A, the fuse curve at the same time T must pass through a point corresponding to 135 A, or more, and so on.

- All parts of the fuse curve must be above the CB curve by a factor of 2 or more:

- Example: where, at a current level I the CB curve passes through a point corresponding to 1.5 seconds, the fuse curve at the same current level I must pass through a point corresponding to 3 seconds, or more, etc.

The factors 1.35 and 2 are based on the maximum manufacturing tolerances given for MV fuses and LV circuit breakers.

In order to compare the two curves, the MV currents must be converted to the equivalent LV currents, or vice-versa.

Selectivity between LV circuit breaker and MV circuit breaker

- All parts of the minimum MV circuit breaker curve must be shifted to the right of the LV CB curve by a factor of 1.35 or more:

- Example: where, at time T, the LV CB curve passes through a point corresponding to 100 A, the MV CB curve at the same time T must pass through a point corresponding to 135 A, or more, and so on.

- All parts of the MV CB curve must be above the LV CB curve. The time difference between the two curves must be 0.3 s at least for any value of the current.

The factors 1.35 and 0.3 s are based on the maximum manufacturing tolerances given for MV current transformers, MV protection relay and LV circuit breakers.

B - Connection to the MV utility distribution network

3 Protection against electrical hazards, faults and mis-operations in electrical installations

PB110698.eps



(a) VIP 40 for basic transformer protection

PB110690.eps



(b) VIP 400 series self powered IDMT (Inverse Definite Minimum Time) overcurrent and earth-fault relay

Fig. B23 Examples of self powered relays (Schneider Electric)

3.3 MV/LV transformer protection with circuit breaker

MV/LV transformer protection with circuit-breaker is usually used in large Commercial, Industrial and Building applications and especially when the transformer power exceeds 800 kVA. In these applications, switchboards made of modular units provide high flexibility.

The protection chain of each unit may include self powered relays (see Fig. B23) bringing a high level of safety and optimized CTs (See Fig. B24).

This solution provides interesting benefits concerning:

- The maintenance
- The improvement of protection of the transformer
- The improvement of the selectivity with the LV installation
- The insensitivity to the inrush currents
- The detection of low earth fault currents.

PB110691.eps



Fig. B24 Schneider Electric SM6 and Premset switchboards including MV/LV transformer protection with circuit breaker associated to self powered relay

3 Protection against electrical hazards, faults and mis-operations in electrical installations

3.3.1 Maintenance

Modern protective relays are now almost maintenance free, as they include self testing features. However it remains necessary to check the protection chain at commissioning stage and periodically (every 5 or 10 years).

3.3.2 Protection performance

Circuit breakers combined with electronic protection relays bring many protection selectivity benefits, including:

- coordination with upstream and downstream devices;
- selectivity of inrush currents;
- detection of low level of phase to phase and phase to earth fault currents.

3.3.3 Selectivity with LV installation

In cases where the LV installation includes an incoming LV Air circuit breaker, selectivity with the MV circuit-breaker is easy, as it is possible to choose the right curve in the electronic relay to ensure selectivity between MV and LV protection.

3.3.4 Inrush current

Transformer energizing produces very high transient inrush current that can reach peak values, up to about ten times the peak rated current for step-down transformer, and 25 times for step-up transformer. This is a natural phenomenon and the protection should not operate. The circuit breaker allows high flexibility to avoid tripping current while still maintaining a good level of protection due to the electronic relay time/current characteristic.

3.3.5 Low magnitude phase fault current

A MV/LV transformer has usually a very low failure rate. Most of the faults are interturn faults or phase to earth faults. Phase-to-phase faults between MV bushing are of more seldom occurrences (see Fig. B25).

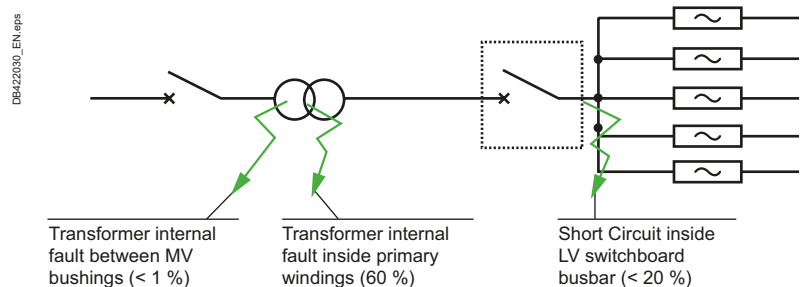


Fig. B25 Localization of a fault

Most common faults are short-circuit inside a turn of the MV winding where the fault level is of low magnitude (1 to 6 times the rated current) (see Fig. B25).

In case of circuit breaker, as soon as the fault reaches the setting, the relay will detect it and trip safely the circuit breaker, disconnecting the MV/LV transformer circuit.

3.3.6 High magnitude fault currents

In the rare event of a short-circuit between MV bushings, the protection must act quickly. In that case the circuit breaker is slower than the MV fuse that has current limiting capabilities. However, the circuit breaker will clear the fault in less than 100 ms, and this is effective enough to avoid any serious damages.

3.3.7 Low level MV earth-faults

In case of either high impedance earth fault on MV winding or solid earth-faults in impedance earthed neutral system, the earth fault magnitude is below the rated current of the transformer. Modern self powered relays integrate sensitive earth fault protection and then provide effective coverage on these conditions.

3 Protection against electrical hazards, faults and mis-operations in electrical installations

3.3.8 Case of public distribution

In public distribution applications, such as MV ring network configurations, utilities look for the simplest repetitive MV/LV substations that are dispersed in a large geographical area. The power of MV/LV transformer is generally limited to 630 kVA or less. Compact and often non extensible 3 function switchgear are specified by the utilities. In these cases, protection of MV/LV transformers by MV fuses offers an optimized solution (see Fig. B26).



Fig. B26 Compact 3 function switchgear

3.4 Interlocks and conditioned operations

Mis-operations in electrical installations may expose operating personnel to danger and lead to electrical incidents.

As a measure of protection against incorrect sequences of manoeuvres by operating personnel, mechanical and electrical interlocks are included in the mechanisms and in control circuits of electrical apparatus.

The interlocks may be classified in two categories:

- Functional interlocks incorporated in MV functional units and dedicated to the operation of the apparatus located in the units only. These interlocks are generally realized by means of specific mechanical devices linked with the mechanisms of the apparatus
- Interlocks between MV functional units or between a functional unit and another equipment such as a MV/LV transformer. Most of these interlocks are realized by means of keys transferred from one equipment to another when they are made free. They may be improved by additional electrical interlocks.

3.4.1 Functional interlocks

Some interlocks are mandatory in MV functional units according to IEC 62271-200, dedicated to metal enclosed switchgear, for example to prevent from:

- closing a switch or circuit breaker on a closed earthing switch;
- closing an earthing switch while the associated switching function is closed

Specific additional interlocks may be specified by the users when required by their operational rules, for example:

- Allowing the opening of a MV cable connection compartment only if the earthing switch associated to the remote end of the MV cable is closed.

The access to a MV compartment requires a certain number of operations which shall be carried out in a pre-determined order. To restore the system to its former condition it is necessary to carry out operations in the reverse order.

Dedicated procedures and instructions may also ensure that the operations are performed in the right sequence.

Hence, the accessibility to an MV compartment can be either interlock controlled or based on procedure. A compartment can also be accessible only by means of tools if its access is not necessary for normal operation or maintenance of the switchgear, or "not accessible", access being either forbidden or impossible (see Fig. B27).

3 Protection against electrical hazards, faults and mis-operations in electrical installations

B20

Type of accessibility to a compartment	Access features	Type of construction
Interlock-controlled	Opening for normal operation and maintenance, e.g. , fuse replacement.	Access is controlled by the construction of the switchgear, i.e. , integrated interlocks prevent impermissible opening.
Procedure-based	Opening for normal operation or maintenance, e.g. , fuse replacement.	Access control via a suitable procedure (work instruction of the operator) combined with a locking device (lock).
Tool-based	Opening not for normal operation and maintenance, e.g., cable testing.	Access only with tool for opening; special access procedure (instruction of the operator).
Not accessible	Opening not possible not intended for operator; opening can destroy the compartment. This applies generally to the gas-filled compartments of gas-insulated switchgear. Because the switchgear is maintenance-free and climate-independent, access is neither required nor possible.	

Fig. B27 Type of accessibility to a compartment

3.4.2 Key interlocking

The interlocks between devices located in separate MV functional units or between a functional unit and access to a MV/LV transformer for example are performed by means of keys.

The principle is based on the possibility of freeing or trapping one or several keys, according to whether or not the required conditions of operation are satisfied.

These conditions ensure the safety of the personnel by the avoidance of incorrect operations.

Note: Concerning the MV/LV substations, the interlocks shall be specified during the design stage. Hence, the apparatuses concerned by the interlocks will be equipped during the manufacturing with the appropriate keys and locking devices.

3.4.3 Service continuity

The notion of Loss of Service Continuity: "LSC" (see Fig. B28 and Fig. B29) defines the conditions of access to any high voltage accessible compartment of a given high voltage functional unit.

IEC 62271-200 defines four categories of Loss of Service Continuity: LSC1, LSC2, LSC2A, LSC2B.

Each category defines which other high voltage compartments and /or other functional units can be kept energized when opening an accessible high-voltage compartment in a given functional unit.

For the single busbar architectures the following definitions are applicable:

■ LSC1 functional unit

Functional unit having one or several high-voltage accessible compartments, such that, when any of these accessible high-voltage compartments is open, the busbar and one or several other functional units of the switchgear must be de-energized

■ LSC2 functional unit

Functional unit having at least an accessible compartment for the high-voltage connection (called connection compartment), such that, when this compartment is open the busbar can remain energized. All the other functional units of the switchgear can continue to be operated normally.

Note: When LSC2 functional units have accessible compartments other than the connection compartment, further subdivisions into LSC2A and LSC2B are defined.

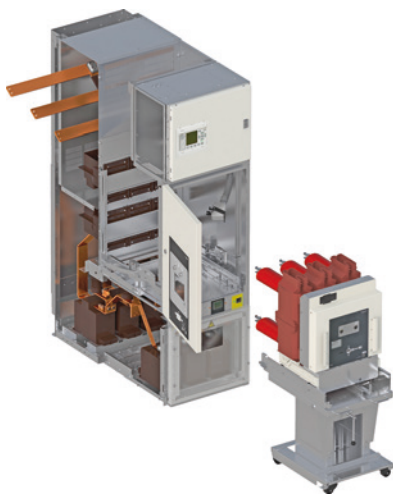
■ LSC2A functional unit

Functional unit having several high-voltage accessible compartments, such that, the busbar can remain energized when any other accessible high voltage compartment is open. All the other functional units of the switchgear can continue to be operated normally

■ LSC2B functional unit

Functional unit having several high-voltage accessible compartments, such that, the high-voltage connections compartment and the busbar can remain energized when any other accessible high voltage compartment is open. All the other functional units of the switchgear can continue to be operated normally.

PB116095.eps



PB116096.eps

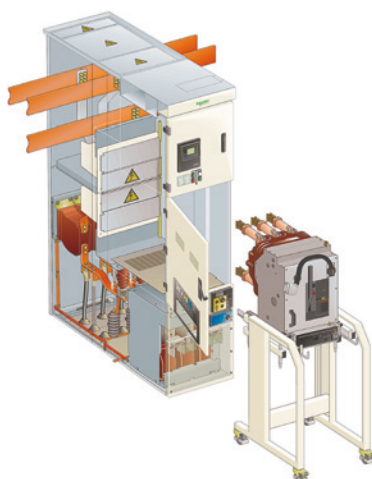


Fig. B28 Example of functional unit architecture with compartments, favoring service continuity

3 Protection against electrical hazards, faults and mis-operations in electrical installations

		Applies when
LSC1	When any compartment of the FU is open the busbar and one or several other FUs of the switchgear must be de-energised	One or several compartments in the considered FU are accessible
LSC2	When the cable compartment is open the busbar can remain energized and all the other FUs of the switchgear can be operated normally	Only the connection compartment in the considered FU is accessible
LSC2A	The busbar can remain energized when any other accessible high voltage compartment is open. All the other functional units of the switchgear can continue to be operated normally	Several compartments in the considered FU are accessible
LSC2B	The high-voltage connections compartment and the busbar can remain energized when any other accessible high voltage compartment is open. All the other functional units of the switchgear can continue to be operated normally	Several compartments in the considered FU are accessible

Fig. B29 Loss of Service Continuity definitions

3.4.4 Interlocks in substations

Example of functional interlocks, embedded in single functional units

- Load break switch closing: the door must be closed and the earthing switch open
- Earthing switch closing: the door must be closed and associated circuit breaker, switch and/or isolating apparatus open
- Access to an accessible compartment: the associated circuit breaker, switch and/or isolating apparatus must be open and the earthing switch closed.

Example of functional interlocks involving several functional units or separate equipment (see Fig. B30):

Let's consider a MV/LV transformer supplied by a MV functional unit including:

- A load break switch
- A set of MV fuses
- An earthing switch

The transformer is installed in a dedicated cubicle.

The access to the MV/LV transformer is authorized when the following conditions are satisfied:

- MV load break switch open
- MV earthing switch closed and locked in close position
- LV circuit breaker open and locked in open position

The required sequence of operations to meet these conditions in full safety is the following:

- **Step 1:** Open the LV CB and lock it open with key "O". Key "O" is then free
- **Step 2:** Open the MV load break switch. Check that the "voltage presence" indicators are extinguished, unlock earthing switch with key O, key O is now trapped
- **Step 3:** Close the MV earthing switch and lock it in close position with key S. Key S is now free
- **Step 4:** Key S allows to open the door of the transformer cubicle. When the door is open, key S is trapped.

The restoration of the supply to the LV switchboard is performed with the execution of the reverse sequence of operation:

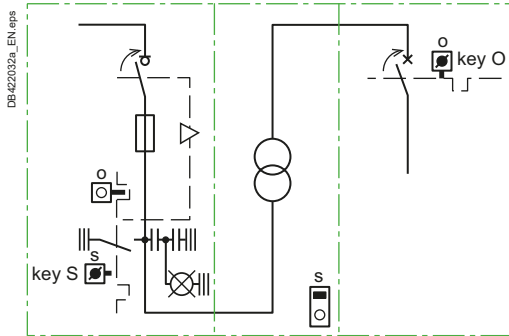
- **Step 1:** Door of the transformer cubicle closing
- **Step 2:** MV earthing switch opening
- **Step 3:** MV load break switch closing
- **Step 4:** LV circuit breaker closing.

Due to LV production, some national regulations require an earthing system as temporary or permanent device to operate on the transformer under full safety, and the earthing connection shall be integrated within the interlock procedure

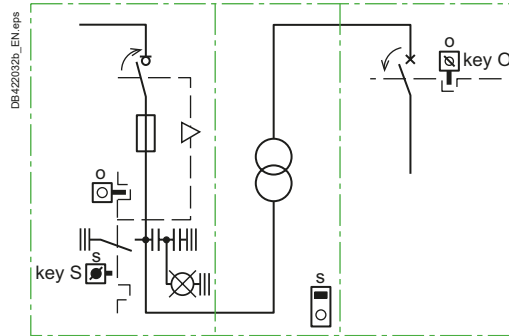
B - Connection to the MV utility distribution network

3 Protection against electrical hazards, faults and mis-operations in electrical installations

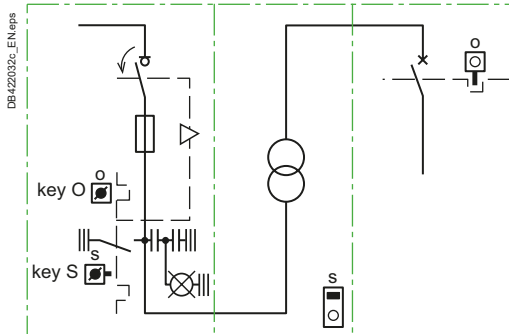
B22



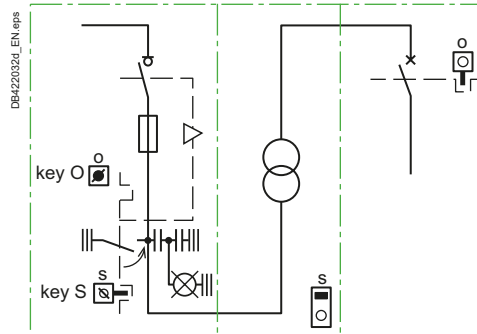
Initial configuration: LV Switchboard energized. MV Load break switch closed. LV circuit breaker closed. Earthing switch open and locked in open position. Key O trapped. Key S trapped.



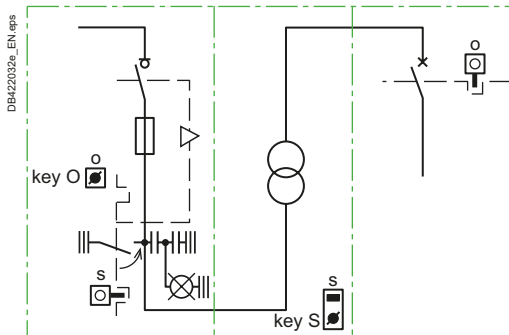
Step 1: Load break switch closed. LV circuit breaker open and locked. Earthing switch open, locked in open position. Key O free, Key S trapped.



Step 2: Load break switch open. LV circuit breaker open and locked in open position. Earthing switch unlocked, Key O trapped, Key S trapped.



Step 3: Load break switch open, LV circuit breaker open and locked in open position. Earthing switch closed and locked, Key O trapped, Key S free.



Step 4: Load break switch open, LV circuit breaker open and locked in open position. Earthing switch closed and locked, door of transformer cubicle open, Key O trapped, Key S trapped.

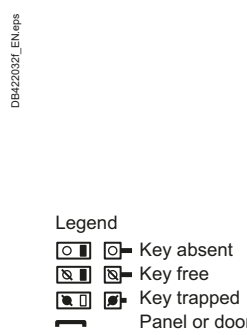


Fig. B30 Example of MV/LV interlocking system

4 The consumer substation with LV metering

4.1 Definition

A consumer substation with LV metering is an electrical installation connected to a utility supply network at a nominal voltage usually between 1 kV - 35 kV, and including generally a single **MV/LV transformer not exceeding 1250 kVA.**

The substation may be installed either in a dedicated room located in a building, or outdoor in a prefabricated housing.

4.2 Functions of a substation with LV metering

4.2.1 Connection to the MV network

Connection to the MV network can be made:

- By a single service cable or overhead line,
- By dual parallel feeders via two mechanically interlocked load-break switches
- Via a ring main unit including two load-break switches.

4.2.2 MV/LV Transformers

Since the ban of PCB in most of the countries, the remaining available insulation technologies for the transformers are:

- **Oil-immersed for transformer preferably located outside premises**
- **Dry-type, cast-resin preferred for transformers located inside premises such as buildings receiving the public.**

Local regulations define where the use of cast resin transformers is mandatory.

4.2.3 Metering

Most of the LV metering and billing principles take into account the MV/ LV transformer losses.

The characteristics and the location of the VT's and CT's dedicated to the metering must comply with the utility's requirements.

The metering current transformers are generally installed in the LV terminal box of the power transformer, alternatively they can be installed in a dedicated compartment in the main LV switchboard.

The compartments housing the metering VT's and CT's are generally sealed by the utility.

The meters are mounted on a dedicated panel accessible by the utility at any time.

4.2.4 Local emergency generators

Emergency standby generators are intended to maintain the supply to the essential loads, in the event of failure of the utility power supply.

A substation with LV metering may include one single emergency generator connected at low voltage level on the main LV distribution switchboard.

The generator may be sized either for the supply of the whole installation or for a part only. In this case a load shedding system must be associated to the generator. The loads requiring an emergency supply may also be grouped on a dedicated LV busbar (see Fig. B31).

An **Uninterruptible Power Supply (UPS)** may be added when required at LV level to avoid the interruption of the supply during the starting of the emergency generator.

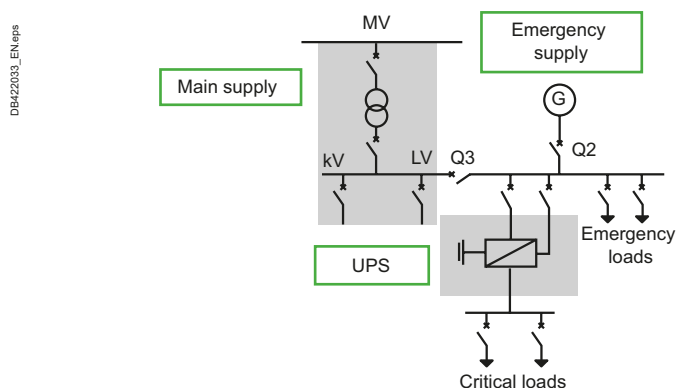


Fig. B31 Emergency generator at LV Level

4 The consumer substation with LV metering

4.2.5 Capacitors

Capacitors are intended to maintain the power factor of the installation at the contractual value specified by the utility. The capacitor banks are connected on the main LV switchboard and can be fixed or adjustable by means of steps controlled by a regulator.

See chapter L "Power Factor Correction"

4.2.6 LV main switchboard

The MV/LV transformer is connected to a main LV distribution switchboard equipped with a LV general circuit breaker ensuring:

- The general protection of the LV installation
- The general isolation of the LV circuits, according to the rules of protection of the persons working in an electrical installations
- The protection of the MV/LV transformer against overload

To comply with the interlocking requirements defined in 3.4, the circuit breaker must be equipped with padlocking facilities for locking it in open position.

4.2.7 Simplified electrical network diagram

The diagram ([Fig. B32](#)) shows:

- The different methods to connect a MV/LV substation to the utility supply:
 - Single-line service
 - Single line service with provision for future connection to a ring or to dual parallel feeders
 - Dual parallel feeders
 - Loop or ring-main service
- The protection of the MV/LV transformer, either by a load break switch or by a circuit breaker
- The LV metering
- The main LV switchboard.

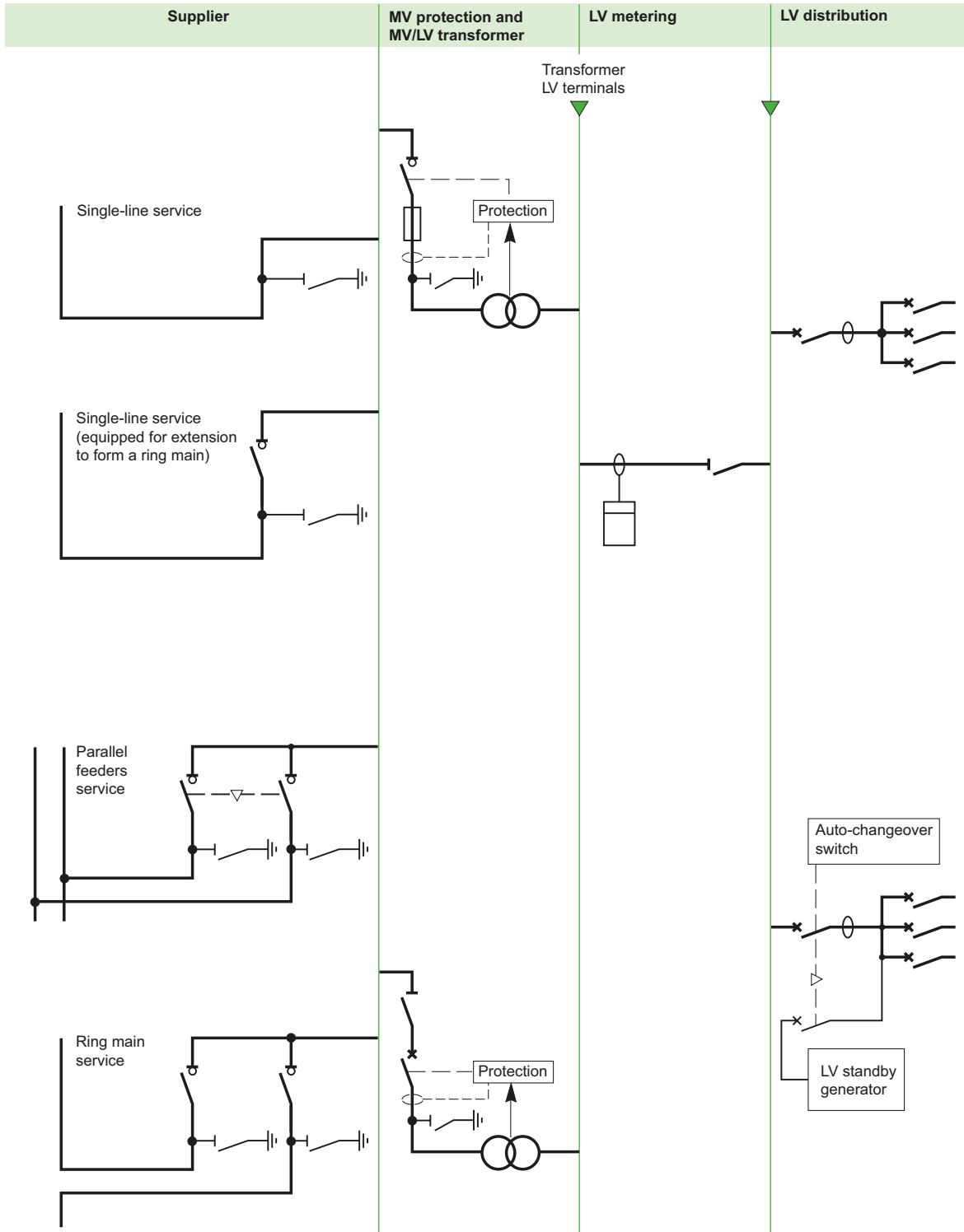
4.3 Choice of LV equipment (Refer to section 6)

MV equipment shall comply with applicable IEC standards and local regulations.

It shall be selected according to the electrical and environmental constraints to which it is supposed to be subjected.

4 The consumer substation with LV metering

DB42034_EN.eps



B25

Fig. B32 Consumer substation with LV metering

5 The consumer substation with MV metering

5.1 Definition

A consumer substation with MV metering is an electrical installation connected to a utility supply system at a nominal voltage usually between 1 kV - 35 kV, which for example may supply:

- A single MV/LV transformer exceeding generally 1250 kVA
- Several MV/LV transformers
- One or several MV/LV secondary substations.

The single line diagram and the layout of a substation with MV metering depend on the complexity of the installation and the presence of secondary substations.

For example a substation may:

- Include one single room containing the MV switchboard, the metering panel, the transformer(s) and the low voltage main distribution board(s),
- Supply one or several transformers, each installed in a dedicated room including the corresponding main LV distribution switchboard
- Supply one or several secondary MV/LV substations.

5.2 Functions of the substation with MV metering

5.2.1 Connection to the MV network

Connection to the MV network can be made:

- By a single service cable or overhead line,
- By dual parallel feeders via two mechanically interlocked load-break switches
- Via a ring main unit including two load-break switches.

5.2.2 MV/LV Transformers and internal MV distribution

As mentioned for substation with LV metering, only oil-immersed and dry type cast-resin transformers are allowed with the same rules of installation.

When the installation includes several MV/LV transformers and/or secondary MV/ LV substations an internal MV distribution network is required.

According to the required level of availability, the MV supplies to the transformers and the secondary substations may be made:

- By simple radial feeders connected directly to the transformers or to the secondary substations
- By one or several rings including the secondary MV/LV substations (**Fig. B10**)
- By duplicate feeders supplying the secondary MV/LV substations.

For the two latter solutions the MV switchboard located in each secondary substation includes two load break switch functional units for the connection of the substation to the internal MV distribution and one transformer protection unit, for each transformer installed in the substation.

The level of availability can be increased by using two transformers operating in parallel or arranged in dual configuration with an automatic change over system.

It is not recommended to use MV/LV transformers above 2500 kVA due to:

- The high level of the short circuit current generated on the main LV switchboard.
- The number of LV cable required for the connection of the transformer to the LV switchboard.

5.2.3 Metering

The characteristics and the location of the VT's and CT's dedicated to the metering shall comply with the utility requirements.

The VT's and CT's are generally installed in the MV switchboard. A dedicated functional unit is in most of the cases required for the voltage transformers while the current transformers may be contained in the functional unit housing the circuit breaker ensuring the general protection of the substation.

The panel that contains the meters shall be accessible by the utility at any time.

5.2.4 Local emergency generators

Emergency standby generators are intended to maintain the power supply to the essential loads in the event of failure of the utility power supply.

According to the energy needs an installation may contain one or several emergency generators.

The generators can be connected:

- At MV level to the MV main substation (see **Fig. B33**). The generator(s) may be sized either for the supply of the whole installation or for a part only. In this case a load shedding system must be associated to the generator(s).
- At LV level on one or several LV switchboards requiring an emergency supply. At each location, the loads requiring an emergency supply may be grouped on a dedicated LV busbar supplied by a local generator (see **Fig. B31**).

5 The consumer substation with MV metering

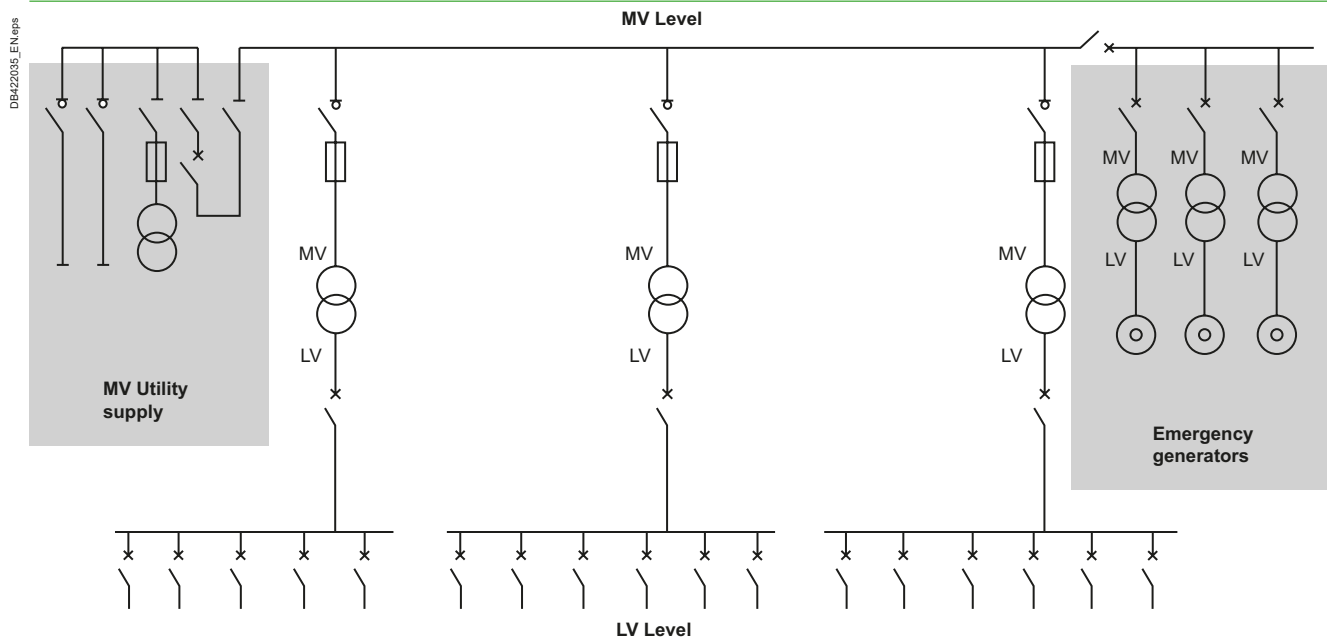


Fig. B33 Connection of emergency generators at MV level

5.2.5 Capacitors

Capacitors are intended to maintain the power factor of the installation at the contractual value specified by the utility. The capacitor banks can be fixed or adjustable by means of steps. They can be connected:

- At MV level to the main MV substation
- At LV level on LV switchboards.

5.2.6 LV main switchboard

Every MV/LV transformer is connected to a main LV switchboard complying with the requirements listed for substation with LV metering (see 4.2.6).

5.2.7 Simplified electrical network diagram

The diagram (Fig. B34) shows:

- The different methods to connect a MV/LV substation to the utility supply:
 - Spur network or single-line service
 - Single line service with provision for future connection to a ring or to dual parallel feeders
 - Dual parallel feeders
 - Loop or ring-main service
- General protection at MV level
- MV metering functions
- Protection of MV circuits
- LV distribution switchboard

Compared with a substation with LV metering, a substation with MV metering includes in addition:

- A MV Circuit breaker functional unit for the general protection of the substation
- A MV metering functional unit
- MV Functional units dedicated to the connection and the protection of:
 - MV/LV transformers
 - MV feeders supplying secondary substations
 - MV capacitor banks
 - Emergency generators

The general protection usually includes protection against phase to phase and phase to earth faults. The settings must be coordinated with the protections installed on the feeder of the primary substation supplying the installation.

5 The consumer substation with MV metering

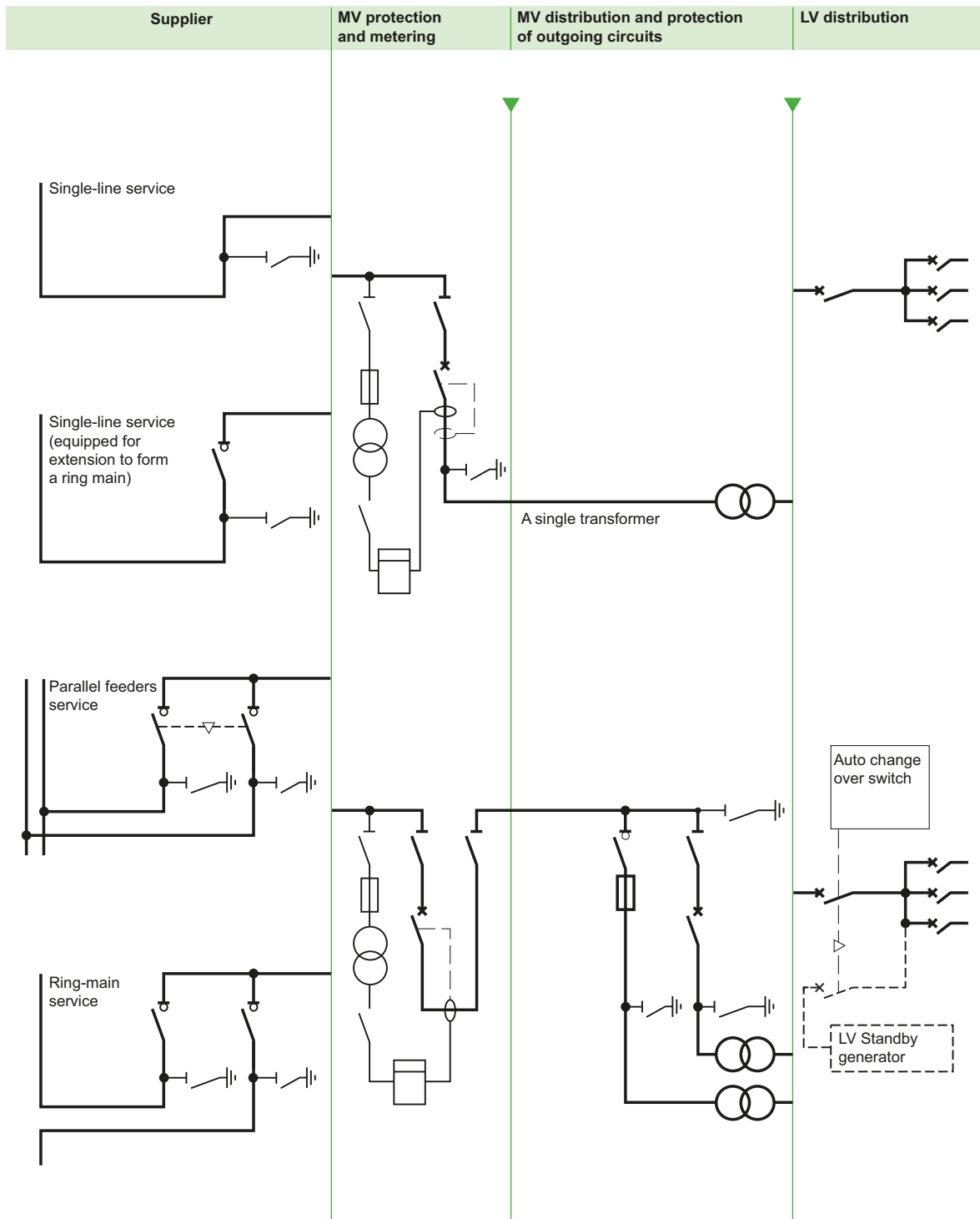


Fig. B34 Consumer substation with MV metering

5.3 Choice of MV equipment (Refer to chapter 6)

MV equipment shall comply with applicable IEC standards and local regulations. It shall be selected according to the electrical and environmental constraints to which it is supposed to be subjected.

6 Choice and use of MV equipment and MV/LV transformer

6.1 Choice of MV equipment

The electrical equipment must withstand both electrical and environmental constraints to which it will be submitted during its life time without any mechanical and dielectric degradation reducing its level of performance.

6.1.1 Standards and specifications

Depending on the devices, components and products included in the MV switchgear, different standards have to be considered for compliance, such as:

- IEC 62271-1, 62271-100, 62271-102, 62271-103, 62271-105, 62271-200.

Local regulations may also require compliance with national standards:

- ANSI/IEEE for USA
- EN for European Union
- GOST for Russia
- GB/DL for China.

6.1.2 Types of MV equipment

Substations shall be designed and built according to local standards and practices. The following types of equipment may be used:

- Compartmented modular units supporting all types of single line diagram and layout
- Compact solution based on ring-main unit solution when the supply is provided by a ring.

A ring main unit includes two load break switches for the connection of the substation to the ring and a transformer protection unit. Some compact RMU designs are particularly suitable when harsh environmental conditions apply.

6.1.3 Modular metal-enclosed switchgear (Fig. B35)

The IEC 62271-200 standard specifies requirements for "AC metal-enclosed switchgear and controlgear for rated voltages above 1 kV and up to and including 52 kV".

Different categories of prefabricated metal enclosed switchgear are defined with respect to the consequences on network service continuity in case of maintenance on the switchgear.

For classification in categories, various aspects have to be taken into account:

- Definition of functional unit: "a switchgear component contained in a metallic enclosure and incorporating all the main and auxiliary circuit equipment required to perform a single function" - usually a modular unit
- Definition of compartment: "a switchgear component contained in a closed metallic enclosure. The manufacturer defines the content (e.g. busbar, cable connections, etc.)"
 - Accessibility to individual compartments (see 3.4.1):
 - Controlled by interlocking
 - In accordance with procedures; for compartments which can be opened during normal operation
 - Using tools; for compartments which should not be opened during normal operation
 - Not accessible for compartments which must not be opened
 - Loss of Service Continuity (LSC) (see 3.4.3) defining the extent to which other compartments can remain energised when one compartment is open. Four LSC categories are defined:
 - LSC1, LSC2, LSC2 A, LSC2 B
 - Definition of partition: "a switchgear component contained in a metallic enclosure and separating one compartment from another". There are two types of partitions :
 - PM: metallic partitions
 - PI: insulating partitions.

Metal-enclosed switchgear can be based on all modern switchgear technologies, such as:

- AIS (Air Insulated Switchgear)
- SIS (Solid Insulated Switchgear)
- GIS (Gas Insulated Switchgear)
- 2SIS (Shielded Solid Insulated Switchgear).

PB116607.eps



Fig. B35 Modular metal-enclosed switchgear

6 Choice and use of MV equipment and MV/LV transformer

B30

PB116689.eps



Fig. B36 SM6 Modular Unit

6.1.4 Choice of MV switchgear panel for a transformer circuit

Three types of MV switchgear panel can be used:

- Load-break switch associated to MV fuses without coordination between the fuses and the breaking capability of the load break switch
- Load-break switch/MV fuses combination with coordination between the fuses and the breaking capability of the load break switch
- Circuit breaker

As explained in paragraph 3.3, a circuit breaker with a dedicated protection relay ensures a better protection of the transformer than the MV fuses coordinated or not with a load break switch.

Note: The fuses used in the load-break switch / fuses combination have striker-pins which ensure tripping of the 3-pole switch as soon as at least one fuse blows.

6.2 Instructions for use of MV equipment

The purpose of this chapter is to provide general guidelines on how to avoid or greatly reduce MV equipment degradation on sites exposed to humidity and pollution.

6.2.1 Normal service conditions for indoor MV equipment

All MV equipment are intended to be used in the normal services conditions as defined in IEC 62271-1 standard "Common specifications for high-voltage switchgear and controlgear".

For instance, regarding humidity, the standard mentions:

- The average value of the relative humidity, measured over a period of 24 h does not exceed 95 %;
- The average value of the water vapour pressure, over a period of 24 h does not exceed 2.2 kPa;
- The average value of the relative humidity, over a period of one month does not exceed 90 %;
- The average value of water vapour pressure, over a period of one month does not exceed 1.8 kPa.

As indicated in the standard, condensation may occasionally occur even under normal conditions. Either switchgear designed for such conditions shall be used and/or special measures concerning the substation premises can be implemented to prevent condensation, such as suitable ventilation and heating of the station.

6.2.2 Use under severe conditions

Under certain severe conditions concerning humidity and pollution, largely beyond the normal conditions of use mentioned above, electrical equipment can be subject to damage by rapid corrosion of metal parts and surface degradation of insulating parts. Examples of suitable measures of protection against condensation and pollution are listed below.

PB116689.eps



Fig. B37 PREMSET. Shielded Solid Insulated MV equipment

Remedial measures for condensation problems

- Carefully design or adapt substation ventilation.
- Avoid temperature variations.
- Eliminate sources of humidity in the substation environment.
- Install an Heating, Ventilation, Air Conditioning unit (HVAC)
- Make sure cabling is in accordance with applicable rules.



Remedial measures for pollution problems

- Equip substation ventilation openings with chevron-type baffles to reduce entry of dust and pollution especially when the transformer is installed in the same room with switchgears or controlgears.
- Install the transformer in a different room to use more efficient ventilation grids if any,
- Keep substation ventilation to the minimum required for evacuation of transformer heat to reduce entry of pollution and dust
- Use MV cubicles with a sufficiently high degree of protection (IP)
- Use air conditioning systems or air forced cooling with filters installed in air inlet to restrict entry of pollution and dust.
- Regularly clean all traces of pollution from metal and insulating parts.
- Instead of using AIS equipment (Fig. B36), use equipment that is insensitive to the environment such as GIS or 2SIS type (see Fig. B37).



humid_conditions.eps

polluted_conditions.eps

6 Choice and use of MV equipment and MV/LV transformer

6.3 Choice of MV/LV transformer

The transformers shall comply with IEC 60076. A transformer is characterized by its electrical parameters, but also by its technology and its conditions of use.

6.3.1 Characteristic parameters of a transformer

- **Rated power:** the apparent-power in kVA on which the values of the design parameters and the construction of the transformer are based. Manufacturing tests and guarantee refer to this rated power
- **Frequency:** for power distribution systems discussed in this guide, the frequency is either 50 Hz or 60 Hz
- **Rated primary voltage:** the service voltage of the electrical network on which the transformer is connected
- **Rated secondary voltage:** the voltage measured between the secondary terminals when the transformer is off load and energized at its rated primary voltage
- **Transformer ratio:** RMS value of the rated primary voltage divided by the RMS value of the rated secondary voltage
- **Rated insulation levels:** are defined by the values of the overvoltage power frequency withstand test, and high voltage lightning impulse tests.

For the voltage levels considered in this guide, the encountered switching over voltages are generally lower than the expected lightning over voltages, so no over voltage switching tests are required for these voltages

- **Off-load tap-Changer switch:** allows to adjust the rated primary voltage and consequently the transformer ratio within the range $\pm 2.5\%$ and $\pm 5\%$. The transformer must be de-energized before the operation of the switch
- **Winding configurations:** Star, Delta and Zigzag high and low voltage windings connections are defined by an alphanumeric code read from the left to the right. The first letter refers to the high voltage winding, the second letter to low voltage winding:
 - Capital letters are used for the high voltage windings
 - D = delta connection
 - Y = star connection
 - Z = zigzag connection
 - N = neutral point brought out to a dedicated terminal
 - Lower-case letters are used for the low voltage winding
 - d = delta
 - y = star
 - z = interconnected-star (or zigzag)
 - n = neutral point brought out to a dedicated terminal
 - A number between 0 and 11 indicates the phase shifting between the primary and the secondary voltages.
 - A common winding configuration used for distribution transformers is Dyn 11:
 - High voltage primary windings connected in Delta
 - Low voltage secondary windings connected in Star
 - Low voltage neutral point brought out to a dedicated terminal.
 - Phase shifting between the primary and the secondary voltage: 30° .

6 Choice and use of MV equipment and MV/LV transformer

B32

PG116700.eps



Fig. B38 Dry type transformer

6.3.2 Technology and utilization of the transformers

There are two basic types of distribution transformer:

- Dry type (cast resin encapsulated) transformer
- Liquid filled (oil-immersed) transformer.

According IEC 60076, the standard conditions of utilization of the transformers for outdoor and indoor installation are the following:

- Altitude ≤ 1000 m
- Maximum ambient temperature: 40 °C
- Monthly average temperature: 30 °C during the hottest month
- Annual average temperature: 20 °C.

For other service conditions:

- For oil immersed transformer the IEC 60076-2 specifies the oil and winding temperature rise.
- For dry type transformer the IEC 60076-11 specifies the thermal class.

The temperature surrounding the transformer is linked to the outdoor service condition, its cooling mode and efficiency when installed in a room, and its load. Two loading guides can help to verify if the transformer is correctly defined according to the expected lifespan, which are respectively the IEC 60076-7 and IEC 60076-12.

An annex within the HV/LV prefabricated substation standard IEC 62271-202 gives several examples of installation, based on these two guides.

6.3.3 Dry type transformers (see Fig. B38)

The dry type transformers shall comply with IEC 60076-11:

Each individual winding of these transformers is casted in resin according to a vacuum dedicated process.

The high voltage winding, the low voltage winding and the frame are separate by air.

The encapsulation of a winding uses three components:

- Epoxy-resin based on biphenol A with a viscosity that ensures complete impregnation of the windings
- Anhydride hardener modified to introduce a degree of resilience in the moulding, essential to avoid the development of cracks during the temperature cycles occurring in normal operation
- Pulverulent additive composed of trihydrated alumina $Al(OH)_3$ and silica which enhances its mechanical and thermal properties, as well as giving exceptional intrinsic qualities to the insulation in the presence of heat.
- This three-component system of encapsulation gives insulation system temperature 155°C (F) with average winding temperature rise limit at rated current $\Delta\theta = 100$ K which provides excellent fire-resisting qualities and immediate self-extinction.

The moulding of the windings contain no halogen compounds (chlorine, bromine, etc.) and no other compounds capable of producing corrosive or toxic pollutants, thereby guaranteeing a high degree of safety to personnel in emergency situations, notably in the event of a fire.

These transformers are classified as nonflammable. Transformers exposed to fire risk with low flammability and self extinguishing in a given time.

They are also exceptionally well adapted for hostile industrial atmospheres and comply with the following class of environment:

- Class E3: up to 95 % of humidity and/or high level of pollution
- Class C3: utilization, transport and storage down to -50 °C.

6 Choice and use of MV equipment and MV/LV transformer

6.3.4 Liquid-filled transformers

The most common insulating liquid used in these transformers is mineral oil, which also acts as a cooling medium.

Mineral oils are specified in IEC 60296, they must not contain PCB (PolyChlorinated Biphenyl).

Mineral oil can be replaced by an alternative insulating liquid such as high density hydrocarbons, esters, silicones, halogen liquids.

The oil being flammable, dedicated safety measures against fire are mandatory in many countries, especially for indoor substations.

The dielectric liquids are classified in several categories according to their fire performance. This latter is assessed according to two criteria (see Fig. B39):

- The flash-point temperature
- The minimum calorific power.

Code	Dielectric fluid	Flash-point (°C)	Minimum calorific power (MJ/kg)
O1	Mineral oil	< 300	-
K1	High-density hydrocarbons	> 300	48
K2	Esters	> 300	34 - 37
K3	Silicones	> 300	27 - 28
L3	Insulating halogen liquids	-	12

Fig. B39 Categories of dielectric fluids

There are two types of liquid filled transformers: Hermetically-sealed totally-filled transformers and Air-breathing transformer.

- Hermetically-sealed totally-filled transformers up to 10 MVA (see Fig. B40)

For this type of transformers the expansion of the insulating liquid is compensated by the elastic deformation of the oil-cooling radiators attached to the tank.

The protection against internal faults is ensured by means of a DGPT device: Detection of Gas, Internal Over Pressure and Oil Over Temperature.

The "total-fill" technique has many advantages:

- Water cannot enter the tank
- Oxidation of the dielectric liquid with atmospheric oxygen is entirely precluded
- No need for an air-drying device, and so no consequent maintenance (inspection and changing of saturated desiccant)
- No need for dielectric-strength test of the liquid for at least 10 years

- Air-breathing transformer (see Fig. B41)

This type of transformer is equipped with an expansion tank or conservator mounted above the main tank. The expansion of the insulating liquid is compensated inside the conservator by the raising of the oil level.

A conservator is required for transformers rated above 10 MVA which is presently the upper limit for "totally filled type transformers".

In the conservator the top of the oil is in contact with the air which must remain dry to avoid any oxidation. This is achieved by admitting the outside air in the conservator through a desiccating device containing silica-gel crystals.

The protection of breathing transformers against internal faults is ensured by means of a buchholz mounted on the pipe linking the main tank to the conservator. The buchholz ensures the detection of gas emission and internal over pressure. The over temperature of the oil is commonly detected by an additional thermostat.

PB116701.eps



Fig. B40 Hermetically-sealed totally-filled oil transformer

PB116886.eps



Fig. B41 Air-breathing oil transformer

6 Choice and use of MV equipment and MV/LV transformer

6.3.5 Choice of technology

As discussed above, the choice of transformer is between liquid-filled or dry type. For ratings up to 10 MVA, totally filled units are available as an alternative to conservator type transformers.

The choice depends on a number of considerations, including:

- Local regulations and recommendations. In some countries dry-type transformers are mandatory for specific buildings such as hospitals, commercial premises etc.
- Risk of fire
- Prices and technical considerations, taking account the relative advantages of each technology.

6.3.6 Determination of the optimal power

The over sizing of a transformer results in:

- Excessive investment
- Un necessarily high no-load losses
- Lower on-load losses.

Under sizing a transformer causes:

■ A reduced efficiency when fully loaded. The highest efficiency is attained in the range 50 % - 70 % of the full load,

- On long-term overload, serious consequences for the transformer, owing to the premature ageing of the windings insulation, and in extreme cases, resulting in failure of insulation and loss of the transformer.

Definition of optimal power

In order to select an optimal power rating for a transformer, the following factors must be taken into account:

- List the consumers and define the factor of utilization k_u and the diversity factor k_s for each load as describe in chapter A
- Determine the load cycle of the installation, noting the duration of loads and overloads
- Take into account all possible future extensions of the installation.
- Arrange for power-factor correction, if justified, in order to:
 - Reduce billing penalties in tariffs based, in part, on maximum kVA demand
 - Reduce the value of the required apparent power: $P(\text{kVA}) = P(\text{kW})/\cos \phi$
- Select the transformer, among the range of standard transformer ratings available.

To avoid over heating and consequently premature ageing of the transformer, it is important to ensure that cooling arrangements and temperature rise of the transformer are adequate.

Notes:

- A wrong choice of the winding temperature rise or thermal class can be at the origin of a reduced lifespan.
- A wrong assessment of the service conditions linked to the load profile can be at the origin of a reduced lifespan. Ex: Photovoltaic production where the load is during the day and when a 70°C maximum ambient temperature gradient is met as in Russia between winter and summer.

6.4 Ventilation in MV Substations

Substation ventilation is generally required to dissipate the heat produced by transformers and other equipment, and to allow drying after particularly wet or humid periods.

However, a number of studies have shown that excessive opening can drastically increase condensation.

The following paragraphs highlight a number of recommendations and good practices to ensure proper ventilation of MV substations. More details to design a natural ventilation of a transformer can be found within the MV Technical Guide § Ventilation.

6.4.1 Remark concerning HV/LV outdoor prefabricated substation in special service conditions

- Any installation of a transformer in the same room or in the same enclosure as HV and LV switchgears will impact the lifespan of the products.
- Any air flow generated by the transformer heating reduces the impact of irradiance. This air flow is the natural convection as required by the IEC 62271-202 standard.
- Any separation of the transformer by a partition wall with the HV and LV switchgears compartment improves the service condition of the switchgears for moderate climates, and avoids exposing them to harsh environment as example wind farms near coastal areas.
- For outdoor installations, any switchgear should be preferably installed in a thermal insulated enclosure protecting it from outdoor service conditions (dust, humidity, solar radiation etc.) especially for very hot and cold climates, and harsh environment.

6 Choice and use of MV equipment and MV/LV transformer

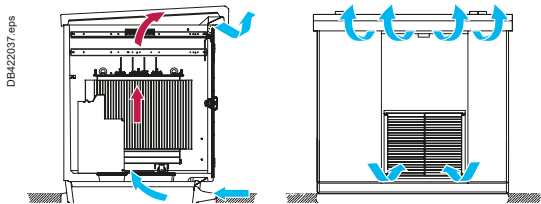


Fig. B42 Two different examples of HV/LV substation designs with natural ventilation, according to the layouts described in Fig. B48



Fig. B43 Example of HV/LV prefabricated substation tested with 1250 kVA liquid filled transformer

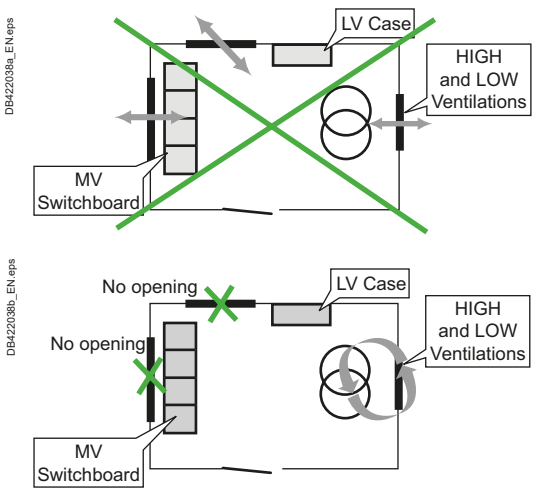


Fig. B44 Ventilation opening locations

6.4.2 Recommendations for HV/LV substation ventilation

General considerations

Ventilation should be kept to the minimum level required. Furthermore, ventilation should never generate sudden temperature variations that can cause the dew point to be reached. For this reason, natural ventilation should be used whenever possible. Heating could be required when the application can be de-energized for a period; this is to maintain a minimum air flow. If forced ventilation is necessary, the fans should operate continuously to avoid temperature fluctuations. When forced ventilation is not enough to assure the indoor service condition of the switchgear or when the installation surrounding is a hazardous area, HVAC unit will be necessary to separate completely the indoor service conditions to the outdoor service conditions.

Natural ventilation is the mostly used method for MV installations (see Fig. B42 and Fig. B43). A guideline for sizing the air entry and exit openings of HV/LV substations is proposed in the "MV Technical Guide" by Schneider Electric.

Ventilation opening locations

To favor evacuation of the heat produced by the transformer via natural convection, ventilation openings should be located at the top and bottom of the wall near the transformer. The heat dissipated by the MV switchboard could be neglected. To avoid condensation problems, the substation ventilation openings should be located as far as possible from the switchboards (see Fig. B44).

Type of ventilation openings

To reduce the entry of dust, pollution, mist, etc., the substation ventilation openings should be equipped with chevron-blade baffles when the transformer is installed in a same room with the switchboards, otherwise the use of higher efficiency ventilation grids is allowed, especially advised when total losses are above 15kW.

Temperature variations inside cubicles

To reduce temperature variations, always install anti-condensation heaters inside MV cubicles if the average relative humidity can remain high over a long period of time. The heaters must operate continuously, 24 hours a day, all year long. Never connect them to a temperature control or regulation system as this could lead to temperature variations and condensation as well as a shorter service life for the heating elements. Make sure the heaters offer an adequate service life.

Temperature variations inside the substation

- The following measures can be taken to reduce temperature variations inside the substation:
- Improve the thermal insulation of the substation to reduce the effects of outdoor temperature variations on the temperature inside the substation
 - Avoid substation heating if possible. If heating is required, make sure the regulation system and/or thermostat are sufficiently accurate and designed to avoid excessive temperature swings (e.g. no greater than 1 °C). If a sufficiently accurate temperature regulation system is not available, leave the heating on continuously, 24 hours a day, all year long
 - Eliminate cold air drafts from cable trenches under cubicles or from openings in the substation (under doors, roof joints, etc.).

Substation environment and humidity

- Various factors outside the substation can affect the humidity inside.
- Plants: avoid excessive plant growth around the substation, and closing any opening.
 - Substation waterproofing: the substation roof must not leak. Avoid flat roofs for which waterproofing is difficult to implement and maintain.
 - Humidity from cable trenches: make sure cable trenches are dry under all conditions. A partial solution is to add sand to the bottom of the cable trench.

6 Choice and use of MV equipment and MV/LV transformer

B36

Pollution protection and cleaning

Excessive pollution favors leakage current, tracking and flashover on insulators. To prevent MV equipment degradation by pollution, it is possible to either protect the equipment against pollution or regularly clean the resulting contamination.

Protection

Indoor MV switchgear can be protected by enclosures providing a sufficiently high degree of protection (IP).

Cleaning

If not fully protected, MV equipment must be cleaned regularly to prevent degradation by contamination from pollution.

Cleaning is a critical process. The use of unsuitable products can irreversibly damage the equipment.

7 Substation including generators and parallel operation of transformers

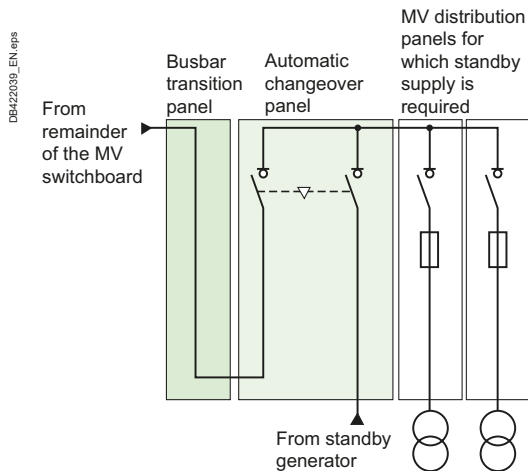


Fig. B45 Automatic change over associated with stand-alone generators

Only generators connected at MV level are considered in this chapter.

7.1 Generators in stand-alone operation, not working in parallel with the supply network

When the installation needs a high level of power availability, one or several MV standby generator set can be used.

In all the stand alone applications the installation includes an automatic changeover able to switch from the utility network supply to the generator(s) in case of failure of the utility supply (see Fig. B45).

The generators are protected by dedicated protections. For medium size generators the following protections are usually used:

- Phase to phase and phase to earth over current
- Percentage biased differential
- Negative sequence over current
- Overload
- Stator frame fault
- Rotor frame fault
- Reverse active power
- Reverse reactive power or loss of field
- Loss of synchronization
- Over and under voltage
- Over and under frequency
- Overheating of bearings.

It shall be noted that, due to the very low short-circuit current of the generator(s) compared to the one delivered from the utility supply network, a great attention must be paid to the settings of the protection and the selectivity. It is recommended when ordering a generator(s) to check with the manufacturer its (their) ability in providing a short circuit current ensuring the operation of the phase to phase short circuit protection. In case of difficulties the boosting of the generator's excitation is required and shall be specified.

Voltage and frequency control

The voltage and the frequency are controlled by the primary regulator(s) of the generator(s). The frequency is controlled by the speed regulator(s), while the voltage is controlled by the excitation regulator(s).

When several generators operate in parallel an additional control loop is required to perform the sharing of the active and reactive power between the generators. The principle of operation is the following:

- The active power delivered by a generator increases when the driven machine is accelerated and vice versa
- The reactive power delivered by a generator increases when its excitation current is increased and vice versa.

Dedicated modules are installed to perform this sharing, generally ensuring other tasks such as the automatic synchronization and coupling of the generators (see Fig. B46).

7.2 Generators operating in parallel with the utility supply network

When one or several generators are intended to operate in parallel with the supply network the agreement of the utility is usually required. The utility specifies the conditions of operation of the generators and specific requirements may be asked. The utility generally requires information concerning the generators, such as:

- Level of the short circuit current injected by the generators in case of fault on the supply network
- Maximum active power intended to be injected in the supply network
- Operation principle of the voltage control
- Capability of the generators to control the power factor of the installation.

In case of fault on the utility supply network, the instantaneous disconnection of the generators is generally required. It is achieved by means of a dedicated protection specified by the utility. This protection may operate according to one or several of the following criteria:

- Under-voltage and over-voltage
- Under-frequency and over-frequency
- Zero sequence overvoltage

The protection generally orders the tripping of the main circuit breaker ensuring the connection of the installation to the utility while the generators continue to supply the totality of the internal consumers or a part only if they are not sized for the full power required (see Fig. B33). In this case load shedding must be simultaneously executed with the tripping of the main circuit breaker.

7 Substation including generators and parallel operation of transformers

Control

When generators at a consumer's substation operate in island mode (Utility power supply disconnected) the voltage and the frequency at the main substation level are both fixed by the generators and consequently the control system of the generators operate in Voltage/Frequency mode (see Fig. B46).

When the utility power supply is connected the voltage and the frequency are both fixed by the utility and the control system of the generators must be switched from Voltage/Frequency mode (V/F control mode) to Active power/Reactive power mode (P/Q control mode) (see Fig. B46).

The function of the P/Q control mode is to control the exchange of active and reactive power with the utility. The typical principle of operation used in most of the applications is the following:

- The amount of the active and reactive power exchanged with the utility are set by the operator. The settings may be specified by the utility
- The control system maintains the values of the exchange at the required values by acting on the speed of the generators for the control of active power and on the excitation current for the control of the reactive power
- The sharing of the active and reactive power between the generators remains in operation.

The P/Q control mode allows:

- To strictly limit the value of the active power imported from the utility at the amount which can't be provided by the generators when the demand of the installation exceed their capability.
- To maintain at zero the imported active power, when the demand of the installation remains below the capability of the generators
- To maintain the power factor of the installation at the contractual value specified by the utility.

When the capability of the generators in providing reactive power is exceeded, the additional reactive power required to comply with the contractual power factor shall be supplied by a dedicated capacitor bank.

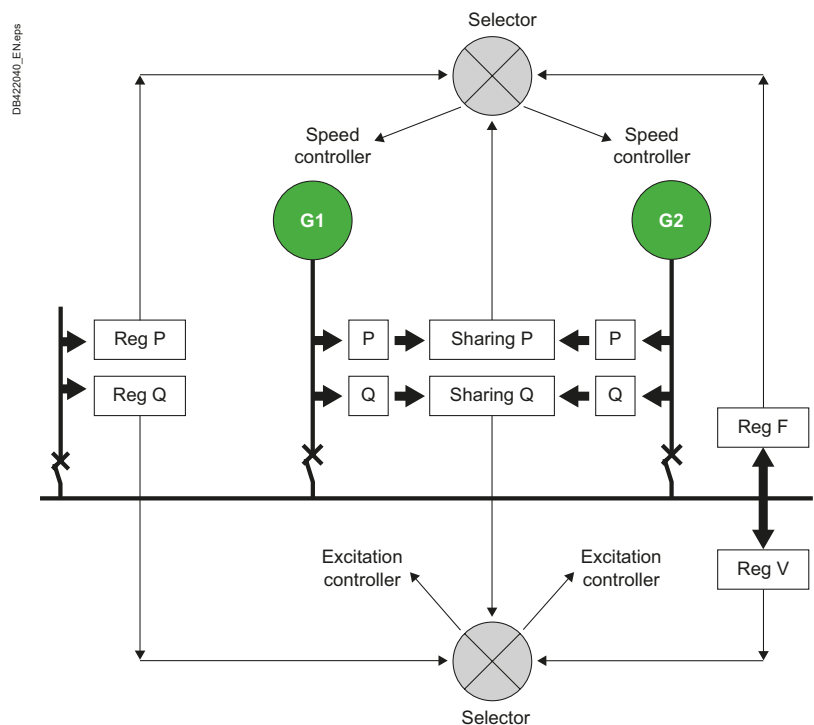


Fig. B46 Control of generators operating in parallel with the utility supply network

7 Substation including generators and parallel operation of transformers

7.3 Parallel operation of transformers

The need to operate two or more transformers in parallel may be required when:

- The level of security of supply to be guaranteed requires to duplicate the sources of supply
- The capacity of an existing transformer is exceeded due to the extension of the installation
- A single large transformer cannot be installed due to the lack of space
- The standardisation of the transformers throughout the installation is required.

It is not recommended to connect more than two transformers in parallel because the short circuit current at low voltage level may become too high.

7.3.1 Total power (kVA)

The total power (kVA) available when two or more transformers are connected in parallel, is equal to the sum of the individual transformer's ratings.

Transformers of equal power rating will each provide a load equal to the total load provided to the installation, divided by the number of transformers working in parallel.

Transformers of unequal power ratings will share the load in proportion to their ratings, providing that their voltage ratios and their short circuit impedances are identical.

7.3.2 Necessary conditions for parallel operation

The following conditions for the connection of power transformers in parallel are required:

It is preferred to connect in parallel transformers having the same characteristics:

- Same voltage ratio
- Same rated power
- Same short circuit impedance.
- Same coupling symbol of windings as for example D yn 11
- Same impedances of the LV links between the transformers and the main LV switchboard where the paralleling is realized.

For transformers having unequal rated power their internal impedances are in the ratio of the rated power of the transformers.

Connection in parallel of transformers having a power ratio equal or higher than two is not recommended.

When the transformers do not comply with the above requirements, recommendations for their paralleling shall be asked to the manufacturer.

8 Types and constitution of MV/LV distribution substations

B40

MV/LV substations may be built in public places, such as parks, residential areas, etc. or in private premises. In this case the utility must have an unrestricted access to the substation. This is normally achieved by locating the substation in such a manner that one of the entrance can be directly accessible at any time from the public way.

8.1 Different types of substations

A substation may be installed:

- Indoor within a building, in a dedicated room
- Outdoor inside a dedicated housing prefabricated or not
- Outdoor without housing
- Pole mounted.

8.2 Indoor substation

8.2.1 General arrangement of a LV metering substation

Figures (Fig. B47 and Fig. B48) shows a typical layout recommended for a LV metering substation.

Remark: The cast-resin dry-type transformer does not need a fire protection oil sump. However, periodic cleaning of the transformer is needed.

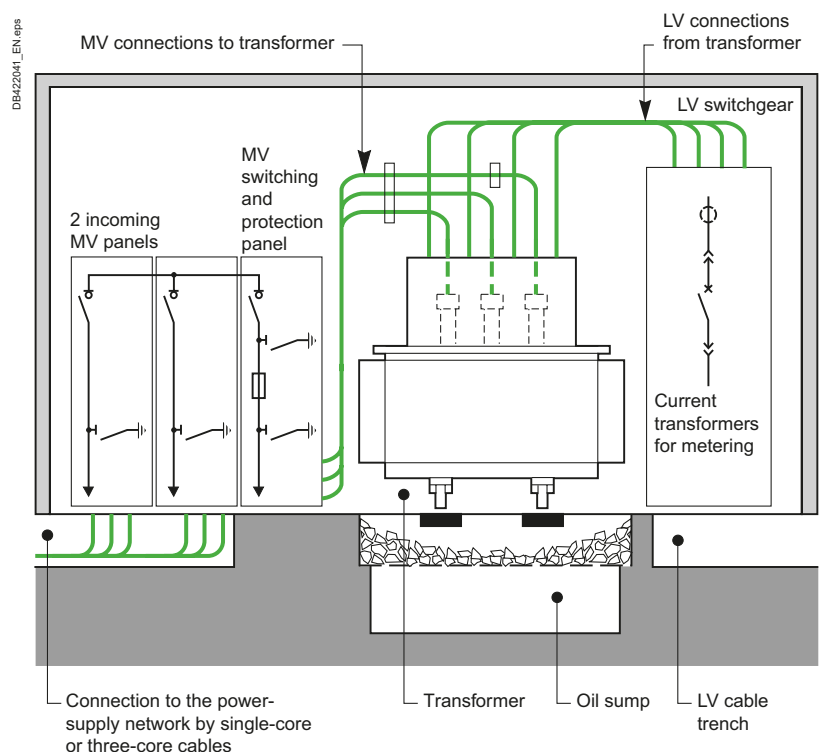


Fig. B47 General arrangement of a LV metering substation

8 Types and constitution of MV/LV distribution substations

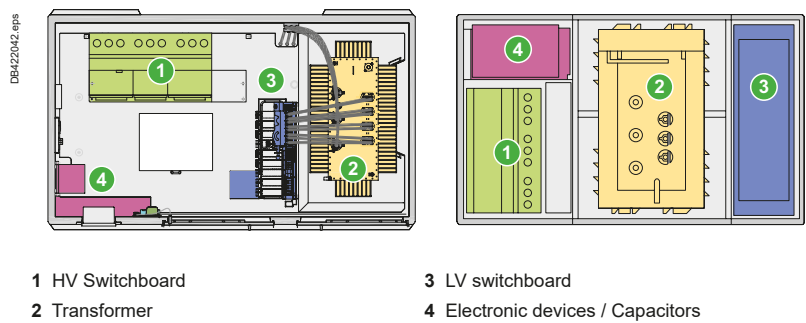


Fig. B48 Examples of general arrangements of LV metering substations, plan view

8.2.2 Connection to the utility and internal MV and LV interconnections

Connection to the MV utility network is made by, and is under the responsibility of the utility.

Connection between the MV switchgear and the transformer may be realized by:

- Short copper bars when the transformer is housed in a panel part of the MV switchboard
- By single-core or three cores screened cables with PR or EPR insulation, and possible connection to the transformers by plugin type terminals.

Connection between the LV terminals of the transformer and the LV switchgear may be realized with:

- Single-core cables
- LV busway with heat-shrinkable insulation.

It is highly recommended to use busway for the connection of transformers requiring more than five single LV cables in parallel per phase. Above five single core cables per phase the equal share of the current in each cable cannot be ensured and the laying becomes a real difficulty.

8.2.3 Earthing circuits

To ensure the safety of the persons an equipotential system must be created within the substation. It is realized according the following recommendations:

- Creation of an earthing electrode under the substation by burying copper conductors
- Inter-connection by means of protective conductors of all the exposed conductive parts of the installation:
 - Enclosures of the electrical equipment
 - Screens of the MV cables
 - Frame of the transformer
 - Metallic doors
 - Etc.
- Connection of all protective conductors at one single common point
- Connection of the common point of the protective conductors and the reinforcing rods of the concrete slab supporting the substation, should be connected to the earth electrode.

8.2.4 Lighting

The supply of the lighting circuits can be taken upstream or downstream from the main incoming LV circuit breaker. Appropriate LV circuit breakers must be provided for the protection of LV lighting circuits.

The lighting must adequately illuminate:

- The switchgear operating handles
- The mechanical flags indicating the position of electrical apparatus
- All the information displayed on the meters and on the protection relays
- All the instruction plates dedicated to the operations and the safety.

For safety reasons, it is recommended to add emergency lighting boxes including each an individual battery.

8 Types and constitution of MV/LV distribution substations

8.2.5 Materials for operation and safety

According to local safety rules, the substation shall be equipped with the following safety equipment:

- Devices for the safe exploitation of the substation:
 - An Insulated stool
 - An insulated mat
 - A pair of insulated gloves stored in a dedicated box
 - A detector of MV voltage presence
- Fire-extinguishing devices complying with the local regulations
- Warning and instruction plates dedicated to:
 - Operation of the substation
 - Safety of the persons
- First-aid care to victims of electrical accidents.

8.3 Outdoor substations

8.3.1 Outdoor substations with prefabricated enclosures

The prefabricated outdoor MV/LV substations (see Fig. B49) comply with IEC 62271-202 standard.

- A type tested prefabricated outdoor substation is subjected to tests and verifications dedicated to:
 - Degree of protection
 - Temperature class
 - Non-flammable materials
 - Mechanical resistance of the enclosure
 - Sound level
 - Insulation level
 - Internal arc withstand
 - Earthing circuit
 - Retention of oil
 - Operation of the substation.

Main benefits:

The prefabricated substations provide a particularly interesting and optimized solution regarding:

- Delivery time
- Construction works
- Erection works
- Commissioning
- Total cost.

DB42204_ENeps

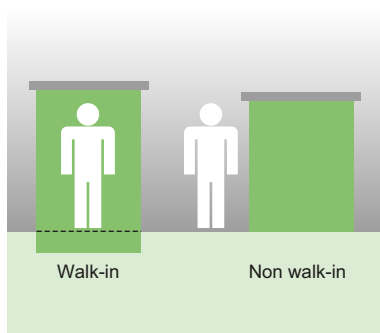
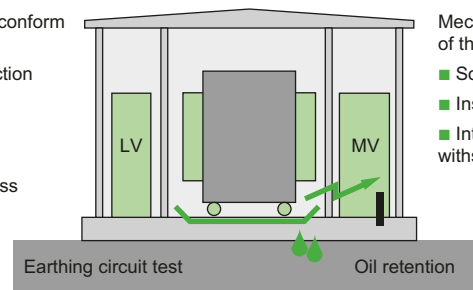


Fig. B50 Walk in and non-walk in type substations

DB422043_ENeps

Use of equipment conform to IEC standards:

- Degree of protection
- Electromagnetic compatibility
- Functional tests
- Temperature class
- Non-flammable materials



Mechanical resistance of the enclosure:

- Sound level
- Insulation level
- Internal arcing withstand

Fig. B49 Type tested substation according to IEC 62271-202

IEC 62271-202 standard defines requirements for two types of outdoor prefabricated substations (see Fig. B50):

- Walk-in type substation
- Non walk-in type substation.

8 Types and constitution of MV/LV distribution substations

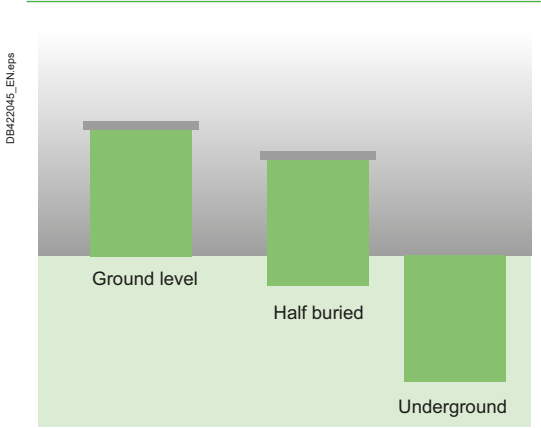


Fig. B51 Outdoor substations. The three type of design

The substations may be situated at ground level, half buried or completely buried (underground substation), resulting in three types of design (see Fig. B51 and Fig. B52).

8.3.2 Outdoor substation without enclosure (see Fig. B53)

This kind of outdoor substations based on weatherproof equipment is commonly used in countries such as UK and India for example.

These substations are generally included in MV rings and include:

- Two functional units dedicated to the connection of the substation to the ring
- One functional unit for the supply and the protection of the MV/LV power transformer generally done by a circuit breaker unit
- One single MV/LV Power transformer
- One LV distribution panel.

The transformer and the LV panel can be installed in dedicated outdoor type housing.

8.3.3 Pole mounted substation

Application

These substations are mainly used for the supply of isolated rural consumers from MV overhead lines.

Constitution

This type of substation includes (see Fig. B54):

- A single pole mounted MV/LV power transformer that is, according to the local rules associated or not with:
 - A load break switch
 - A set of three fuses
 - A set of three surge arrestors
- A low voltage circuit breaker
- An earthing electrode realized at the bottom of the pole supporting the equipment.

The location of the substation must allow easy access of the personnel and handling equipment.



(a) Ground level walk in type substation



(b) Half buried non walk in type substation

Fig. B52 Outdoor substations

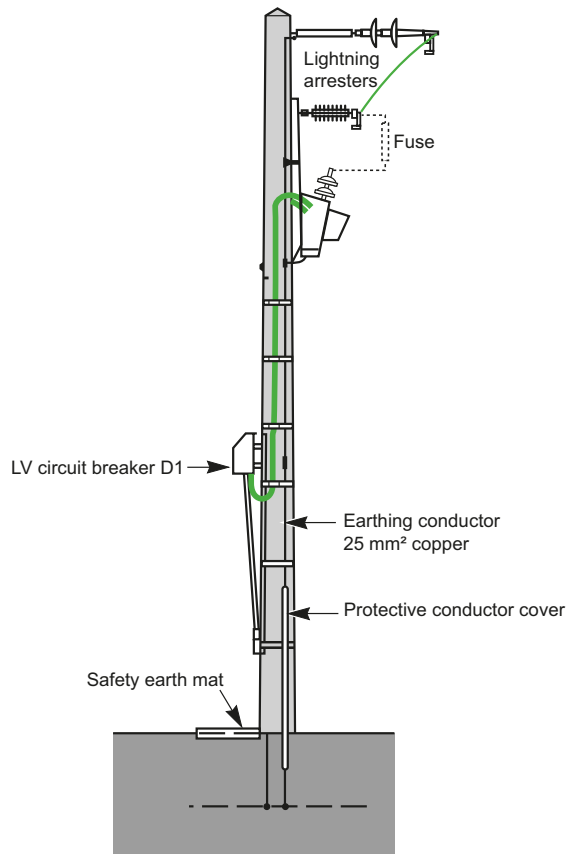


Fig. B54 Pole mounted MV/LV substation



Fig. B53 Outdoor substation without enclosure

B - Connection to the MV utility distribution network

B44

Connection to the LV utility distribution network

1	Low-voltage utility distribution networks	C2
	1.1 Low-voltage consumers.....	C2
	1.2 LV distribution networks.....	C10
	1.3 The consumer-service connection.....	C11
	1.4 Quality of supply voltage.....	C15
2	Tariffs and metering	C16

1 Low-voltage utility distribution networks

C2

The most-common LV supplies are within the range 120 V single phase to 240/415 V 3-phase 4-wires.

Loads up to 250 kVA can be supplied at LV, but power-supply organizations generally propose a MV service at load levels for which their LV networks are marginally adequate.

An international voltage standard for 3-phase 4-wire LV systems is recommended by the IEC 60038 to be 230/400 V

1.1 Low-voltage consumers

In Europe, the transition period on the voltage tolerance to “230V/400V ±10%” has been extended for another 5 years up to the year 2008.

Low-voltage consumers are, by definition, those consumers whose loads can be satisfactorily supplied from the low-voltage system in their locality.

The voltage of the local LV network may be 120/208 V or 240/415 V, i.e. the lower or upper extremes of the most common 3-phase levels in general use, or at some intermediate level, as shown in Fig. C1 and Fig. C2.

Country	Frequency & tolerance (Hz & %)	Domestic (V)	Commercial (V)	Industrial (V)
Afghanistan	50 220 [k]	380/220 [a]	380/220	380/220 [a]
Algeria	50 ±1.5	220/127 [e] 220 [k]	380/220 [a] 220/127 [a]	10,000 5,500 6,600 380/220 [a]
Angola	50	380/220 [a] 220 [k]	380/220 [a]	380/220 [a]
Antigua and Barbuda	60	240 [k] 120 [k]	400/230 [a] 120/208 [a]	400/230 [a] 120/208 [a]
Argentina	50 ±2	380/220 [a] 220 [k]	380/220 [a] 220 [k]	
Armenia	50 ±5	380/220 [a] 220 [k]	380/220 [a] 220 [k]	380/220 [a]
Australia	50 ±0.1	415/240 [a] 240 [k]	415/240 [a] 440/250 [a] 440 [m]	22,000 11,000 6,600 415/240 440/250
Austria	50 ±0.1	230 [k]	380/220 [a] 220 [a]	5,000 380/220 [a]
Azerbaijan	50 ±0.1	208/120 [a] 240/120 [k]	208/120 [a] 240/120 [k]	
Bahrain	50 ±0.1	415/240 [a] 240 [k]	415/240 [a] 240 [k]	11,000 415/240 [a] 240 [k]
Bangladesh	50 ±2	410/220 [a] 220 [k]	410/220 [a]	11,000 415/240 [a] 240 [k]
Barbados	50 ±6	230/115 [l] 115 [k]	230/115 [l] 200/115 [a] 220/115 [a]	230/400 [g] 230/155 [l]
Belarus	50	380/220 [a] 220 [k] 220/127 [a] 127 [k]	380/220 [a] 220 [k]	380/220 [a]
Belgium	50 ±5	230 [k] 230 [a] 3N, 400	230 [k] 230 [a] 3N, 400	6,600 10,000 11,000 15,000
Bolivia	50 ±0.5	230 [k]	400/230 [a] 230 [k]	400/230 [a]
Botswana	50 ±3	220 [k]	380/220 [a]	380/220 [a]
Brazil	60 ±3	220 [k] [a] 127 [k] [a]	220/380 [a] 127/220 [a]	69,000 23,200 13,800 11,200 220/380 [a] 127/200 [a]
Brunei	50 ±2	230	230	11,000 68,000
Bulgaria	50 ±0.1	220	220/240	1,000 690 380
Cambodia	50 ±1	220 [k]	220/300	220/380
Cameroon	50 ±1	220/260 [k]	220/380 [a]	220/380 [a]

Fig. C1 Voltage of local LV network and their associated circuit diagrams

1 Low-voltage utility distribution networks

Country	Frequency & tolerance (Hz & %)	Domestic (V)	Commercial (V)	Industrial (V)
Canada	60 ±0.02	120/240 [ii]	347/600 a) 480 [f] 240 [f] 120/240 [ii] 120/208 [a]	7,200/12,500 347/600 [a] 120/208 600 [f] 480 [f] 240 [f]
Cap Verde		220	220	380/400
Chad	50 ±1	220 [k]	220 [k]	380/220 [a]
Chile	50 ±1	220 [k]	380/220 [a]	380/220 [a]
China	50 ±0.5	220 [k]	380/220 [a] 220 [k]	380/220 [a] 220 [k]
Colombia	60 ±1	120/240 [g] 120 [k]	120/240 [g] 120 [k]	13,200 120/240 [g]
Congo	50	220 [k]	240/120 [ii] 120 [k]	380/220 [a]
Croatia	50	400/230 [a] 230 [k]	400/230 [a] 230 [k]	400/230 [a]
Cyprus	50 ±0.1	240 [k]	415/240	11,000 415/240
Czech Republic	50 ±1	230	500 230/400	400,000 220,000 110,000 35,000 22,000 10,000 6,000 3,000
Denmark	50 ±1	400/230 [a]	400/230 [a]	400/230 [a]
Djibouti	50		400/230 [a]	400/230 [a]
Dominica	50	230 [k]	400/230 [a]	400/230 [a]
Egypt	50 ±0.5	380/220 [a] 220 [k]	380/220 [a] 220 [k]	66,000 33,000 20,000 11,000 6,600 380/220 [a]
Estonia	50 ±1	380/220 [a] 220 [k]	380/220 [a] 220 [k]	380/220 [a]
Ethiopia	50 ±2.5	220 [k]	380/231 [a]	15000 380/231 [a]
Falkland Islands	50 ±3	230 [k]	415/230 [a]	415/230 [a]
Fidji Island	50 ±2	415/240 [a] 240 [k]	415/240 [a] 240 [k]	11,000 415/240 [a]
Finland	50 ±0.1	230 [k]	400/230 [a]	690/400 400/230 [a]
France	50 ±1	400/230 [a] 230 [a]	400/230 690/400 590/100	20,000 10,000 230/400
Gambia	50	220 [k]	220/380	380
Georgia	50 ±0.5	380/220 [a] 220 [k]	380/220 [a] 220 [k]	380/220 [a]
Germany	50 ±0.3	400/230 [a] 230 [k]	400/230 [a] 230 [k]	20,000 10,000 6,000 690/400 400/230
Ghana	50 ±5	220/240	220/240	415/240 [a]
Gibraltar	50 ±1	415/240 [a]	415/240 [a]	415/240 [a]
Greece	50	220 [k] 230	6,000 380/220 [a]	22,000 20,000 15,000 6,600
Granada	50	230 [k]	400/230 [a]	400/230 [a]
Hong Kong	50 ±2	220 [k]	380/220 [a]	11,000 386/220 [a]
Hungary	50 ±5	220	220	220/380
Ideland	50 ±0.1	230	230/400	230/400
India	50 ±1.5	440/250 [a] 230 [k]	440/250 [a] 230 [k]	11,000 400/230 [a] 440/250 [a]

Fig. C1 Voltage of local LV network and their associated circuit diagrams

C - Connection to the LV utility distribution network

1 Low-voltage utility distribution networks

C4

Country	Frequency & tolerance (Hz & %)	Domestic (V)	Commercial (V)	Industrial (V)
Indonesia	50 ±2	220 [k]	380/220 [a]	150,000 20,000 380/220 [a]
Iran	60 ±5	220 [k]	380/220 [a]	20,000 11,000 400/230 [a] 380/220 [a]
Iraq	50	220 [k]	380/220 [a]	11,000 6,600 3,000 380/220 [a]
Ireland	50 ±2	230 [k]	400/230 [a]	20,000 12,600 6,300 400/230 [a]
Israel	50 ±0.2	400/230 [a] 230 [k]	400/230 [a] 230 [k]	22,000 12,600 6,300 400/230 [a]
Italy	50 ±0.4	400/230 [a] 230 [k]	400/230 [a]	20,000 15,000 10,000 400/230 [a]
Jamaica	50 ±1	220/110 [g] [i]	220/110 [g] [i]	4,000 2,300 220/110 [g]
Japan (east)	+0.1 -0.3	200/100 [h]	200/100 [h] (up to 50 kW)	140,000 60,000 20,000 6,000 200/100 [h]
Jordan	50	380/220 [a] 400/230 [k]	380/220 [a]	400 [a]
Kazakhstan	50	380/220 [a] 220 [k] 220/127 [a] 127 [k]	380/220 [a] 220 [k]	380/220 [a]
Kenya	50	240 [k]	415/240 [a]	415/240 [a]
Kirghizia	50	380/220 [a] 220 [k] 220/127 [a] 127 [k]	380/220 [a] 220 [k]	380/220 [a]
Korea (North)	60 +0, -5	220 [k]	380/220 [a]	13,600 6,800
Korea (South)	60 ±0.2	220 [k]	380/220 [a]	380/220 [a]
Kuwait	50 ±3	240 [k]	415/240 [a]	415/240 [a]
Laos	50 ±8	380/220 [a]	380/220 [a]	380/220 [a]
Lestotho		220 [k]	380/220 [a]	380/220 [a]
Latvia	50 ±0.4	380/220 [a] 220 [k]	380/220 [a] 220 [k]	380/220 [a]
Lebanon	50	220 [k]	380/220 [a]	380/220 [a]
Libya	50	230 [k] 127 [k]	400/230 [a] 220/127 [a] 230 [k] 127 [k]	400/230 [a] 220/127 [a]
Lithuania	50 ±0.5	380/220 [a] 220 [k]	380/220 [a] 220 [k]	380/220 [a]
Luxembourg	50 ±0.5	380/220 [a]	380/220 [a]	20,000 15,000 5,000
Macedonia	50	380/220 [a] 220 [k]	380/220 [a] 220 [k]	10,000 6,600 380/220 [a]
Madagascar	50	220/110 [k]	380/220 [a]	35,000 5,000 380/220
Malaysia	50 ±1	240 [k] 415 [a]	415/240 [a]	415/240 [a]

Fig. C1 Voltage of local LV network and their associated circuit diagrams

1 Low-voltage utility distribution networks

Country	Frequency & tolerance (Hz & %)	Domestic (V)	Commercial (V)	Industrial (V)
Malawi	50 ±2.5	230 [k]	400 [a] 230 [k]	400 [a]
Mali	50	220 [k] 127 [k]	380/220 [a] 220/127 [a] 220 [k] 127 [k]	380/220 [a] 220/127 [a]
Malta	50 ±2	240 [k]	415/240 [a]	415/240 [a]
Martinique	50	127 [k]	220/127 [k] 127 [k]	220/127 [k]
Mauritania	50 ±1	230 [k]	400/230 [a]	400/230 [a]
Mexico	60 ±0.2	12/220 [a] 120/240 [i]	127/220 [a] 120/240 [i]	4,160 13,800 23,000 34,500 277/480 [a] 127/220 [b]
Moldavia	50	380/220 [a] 220 [k] 220/127 [a] 127 [k]	380/220 [a] 220 [k]	380/220 [a]
Morocco	50 ±5	380/220 [a] 220/110 [a]	380/220 [a]	225,000 150,000 60,000 22,000 20,000
Mozambique	50	380/220 [a]	380/220 [a]	6,000 10,000
Nepal	50 ±1	220 [k]	440/220 [a] 220 [k]	11,000 440/220 [a]
Netherlands	50 ±0.4	230/400 [a] 230 [k]	230/400 [a]	25,000 20,000 12,000 10,000 230/400
New Zealand	50 ±1.5	400/230 [e] [a] 230 [k] 460/230 [e]	400/230 [e] [a] 230 [k]	11,000 400/230 [a]
Niger	60 +1	230 [k]	380/220 [a]	15,000 380/220 [a]
Nigeria	50 ±1	230 [k] 220 [k]	400/230 [a] 380/220 [a]	15,000 11,000 400/230 [a] 380/220 [a]
Norway	50 ±2	230/400	230/400	230/400 690
Oman	50	240 [k]	415/240 [a] 240 [k]	415/240 [a]
Pakistan	50	230 [k]	400/230 [a] 240 [k]	415/230 [a]
Papua New Guinea	50 ±2	240 [k]	415/240 [a] 240 [k]	22,000 11,000 415/240 [a]
Paraguay	50 ±0.5	220 [k]	380/220 [a] 220 [k]	22,000 380/220 [a]
Philippines (Rep of the)	50 ±0.16	110/220 [i]	13,800 4,160 2,400 110/220 [h]	13,800 4,160 2,400 440 [b] 110/220 [h]
Poland	50 ±0.1	230 [k]	400/230 [a]	1,000 690/400 400/230 [a]
Portugal	50 ±1	380/220 [a] 220 [k]	15,000 5,000 380/220 [a] 220 [k]	15,000 5,000 380/220 [a]
Qatar	50 ±0.1	415/240 [k]	415/240 [a]	11,000 415/240 [a]
Romania	50 ±0.5	220 [k] 220/380 [a]	220/380 [a]	20,000 10,000 6,000 220/380 [a]

Fig. C1 Voltage of local LV network and their associated circuit diagrams

1 Low-voltage utility distribution networks

C6

Country	Frequency & tolerance (Hz & %)	Domestic (V)	Commercial (V)	Industrial (V)
Russia	50 ±0.2	380/220 ^[a]	380/220 ^[a]	380/220 ^[a]
Rwanda	50 ±1	220 ^[k]	380/220 ^[a]	15,000 6,600 380/220 ^[a]
Saint Lucia	50 ±3	240 ^[k]	415/240 ^[a]	11,000 415/240 ^[a]
Samoa		400/230		
San Marino	50 ±1	230/220	380	15,000 380
Saudi Arabia	60	220/127 ^[a]	220/127 ^[a] 380/220 ^[a]	11,000 7,200 380/220 ^[a]
The Solomon Islands	50 ±2	240	415/240	415/240
Senegal	50 ±5	220 ^[a] 127 ^[k]	380/220 ^[a] 220/127 ^[k]	90,000 30,000 6,600
Serbia and Montenegro	50	380/220 ^[a] 220 ^[k]	380/220 ^[a] 220 ^[k]	10,000 6,600 380/220 ^[a]
Seychelles	50 ±1	400/230 ^[a]	400/230 ^[a]	11,000 400/230 ^[a]
Sierra Leone	50 ±5	230 ^[k]	400/230 ^[a]	22,000 6,600 400/230 ^[a]
Singapore	50	400/230 ^[a] 230 ^[k]	400/230 ^[a]	22,000 6,600 400/230 ^[a]
Slovakia	50 ±0.5	230	230	230/400
Slovenia	50 ±0.1	220 ^[k]	380/220 ^[a]	10,000 6,600 380/220 ^[a]
Somalia	50	230 ^[k] 220 ^[k] 110 ^[k]	440/220 ^[i] 220/110 ^[i] 230 ^[k]	440/200 ^[g] 220/110 ^[g]
South Africa	50 ±2.5	433/250 ^[a] 400/230 ^[a] 380/220 ^[a] 220 ^[k]	11,000 6,600 3,300 433/250 ^[a] 400/230 ^[a] 380/220 ^[a]	11,000 6,600 3,300 500 ^[b] 380/220 ^[a]
Spain	50 ±3	380/220 ^[a] ^[e] 220 ^[k] 220/127 ^[a] 127 ^[k]	380/220 ^[a] 220/127 ^[a] ^[e]	15,000 11,000 380/220 ^[a]
Sri Lanka	50 ±2	230 ^[k]	400/230 ^[a] 230 ^[k]	11,000 400/230 ^[a]
Sudan	50	240 ^[k]	415/240 ^[a] 240 ^[k]	415/240 ^[a]
Swaziland	50 ±2.5	230 ^[k]	400/230 ^[a] 230 ^[k]	11,000 400/230 ^[a]
Sweden	50 ±0.5	400/230 ^[a] 230 ^[k]	400/230 ^[a] 230 ^[k]	6,000 400/230 ^[a]
Switzerland	50 ±2	400/230 ^[a]	400/230 ^[a]	20,000 10,000 3,000 1,000 690/500
Syria	50	220 ^[k] 115 ^[k]	380/220 ^[a] 220 ^[k] 200/115 ^[a]	380/220 ^[a]
Tadzhikistan	50	380/220 ^[a] 220 ^[k] 220/127 ^[a] 127 ^[k]	380/220 ^[a] 220 ^[k]	380/200 ^[a]
Tanzani	50	400/230 ^[a]	400/230 ^[a]	11,000 400/230 ^[a]
Thailand	50	220 ^[k]	380/220 ^[a] 220 ^[k]	380/220 ^[a]
Togo	50	220 ^[k]	380/220 ^[a]	20,000 5,500 380/220 ^[a]

Fig. C1 Voltage of local LV network and their associated circuit diagrams

1 Low-voltage utility distribution networks

Country	Frequency & tolerance (Hz & %)	Domestic (V)	Commercial (V)	Industrial (V)
Tunisia	50 ±2	380/220 ^[a] 220 ^[k]	380/220 ^[a] 220 ^[k]	30,000 15,000 10,000 380/220 ^[a]
Turkmeristan	50	380/220 ^[a] 220 ^[k] 220/127 ^[a] 127 ^[k]	380/220 ^[a] 220 ^[k]	380/220 ^[a]
Turkey	50 ±1	380/220 ^[a]	380/220 ^[a]	15,000 6,300 380/220 ^[a]
Uganda	+ 0.1	240 ^[k]	415/240 ^[a]	11,000 415/240 ^[a]
Ukraine	+ 0.2 / -1.5	380/220 ^[a] 220 ^[k]	380/220 ^[a] 220 ^[k]	380/220 ^[a] 220 ^[k]
United Arab Emirates	50 ±1	220 ^[k]	415/240 ^[a] 380/220 ^[a] 220 ^[k]	6,600 415/240 ^[a] 380/220 ^[a]
United Kingdom (except Northern Ireland)	50 ±1	230 ^[k]	400/230 ^[k]	22,000 11,000 6,600 3,300 400/230 ^[a]
United Kingdom (including Northern Ireland)	50 ±0.4	230 ^[k] 220 ^[k]	400/230 ^[a] 380/220 ^[a]	400/230 ^[a] 380/220 ^[a]
United States of America Charlotte (North Carolina)	60 ±0.06	120/240 ^[i] 120/208 ^[a]	265/460 ^[a] 120/240 ^[i] 120/208 ^[a]	14,400 7,200 2,400 575 ^[f] 460 ^[f] 240 ^[f] 265/460 ^[a] 120/240 ^[i] 120/208 ^[a]
United States of America Detroit (Michigan)	60 ±0.2	120/240 ^[i] 120/208 ^[a]	480 ^[f] 120/240 ^[h] 120/208 ^[a]	13,200 4,800 4,160 480 ^[f] 120/240 ^[h] 120/208 ^[a]
United States of America Los Angeles (California)	60 ±0.2	120/240 ^[i]	4,800 120/240 ^[g]	4,800 120/240 ^[g]
United States of America Miami (Florida)	60 +0.3	120/240 ^[i] 120/208 ^[a]	120/240 ^[i] 120/240 ^[h] 120/208 ^[a]	13,200 2,400 480/277 ^[a] 120/240 ^[h]
United States of America New York (New York)	60	120/240 ^[i] 120/208 ^[a]	120/240 ^[i] 120/208 ^[a] 240 ^[f]	12,470 4,160 270/480 ^[a] 480 ^[f]
United States of America Pittsburg (Pennsylvania)	60 ±0.03	120/240 ^[i]	265/460 ^[a] 120/240 ^[i] 120/208 ^[a] 460 ^[f] 230 ^[f]	13,200 11,500 2,400 265/460 ^[a] 120/208 ^[a] 460 ^[f] 230 ^[f]
United States of America Portland (Oregon)	60	120/240 ^[i]	227/480 ^[a] 120/240 ^[i] 120/208 ^[a] 480 ^[f] 240 ^[f]	19,900 12,000 7,200 2,400 277/480 ^[a] 120/208 ^[a] 480 ^[f] 240 ^[f]
United States of America San Francisco (California)	60 ±0.08	120/240 ^[i]	277/480 ^[a] 120/240 ^[i]	20,800 12,000 4,160 277/480 ^[a] 120/240 ^[g]

Fig. C1 Voltage of local LV network and their associated circuit diagrams

1 Low-voltage utility distribution networks

C8

Country	Frequency & tolerance (Hz & %)	Domestic (V)	Commercial (V)	Industrial (V)
United States of America Toledo (Ohio)	60 ±0.08	120/240 [i] 120/208 [a]	277/480 [c] 120/240 [h] 120/208 [i]	12,470 7,200 4,800 4,160 480 [f] 277/480 [a] 120/208 [a]
Uruguay	50 ±1	220 [b] [k]	220 [b] [k]	15,000 6,000 220 [b]
Vietnam	50 ±0.1	220 [k]	380/220 [a]	35,000 15,000 10,000 6,000
Yemen	50	250 [k]	440/250 [a]	440/250 [a]
Zambia	50 ±2.5	250 [k]	380/220 [a]	380 [a]
Zimbabwe	50	250 [k]	390/22 [a]	11,000 390/225 [a]

Fig. C1 Voltage of local LV network and their associated circuit diagrams

Circuit diagrams

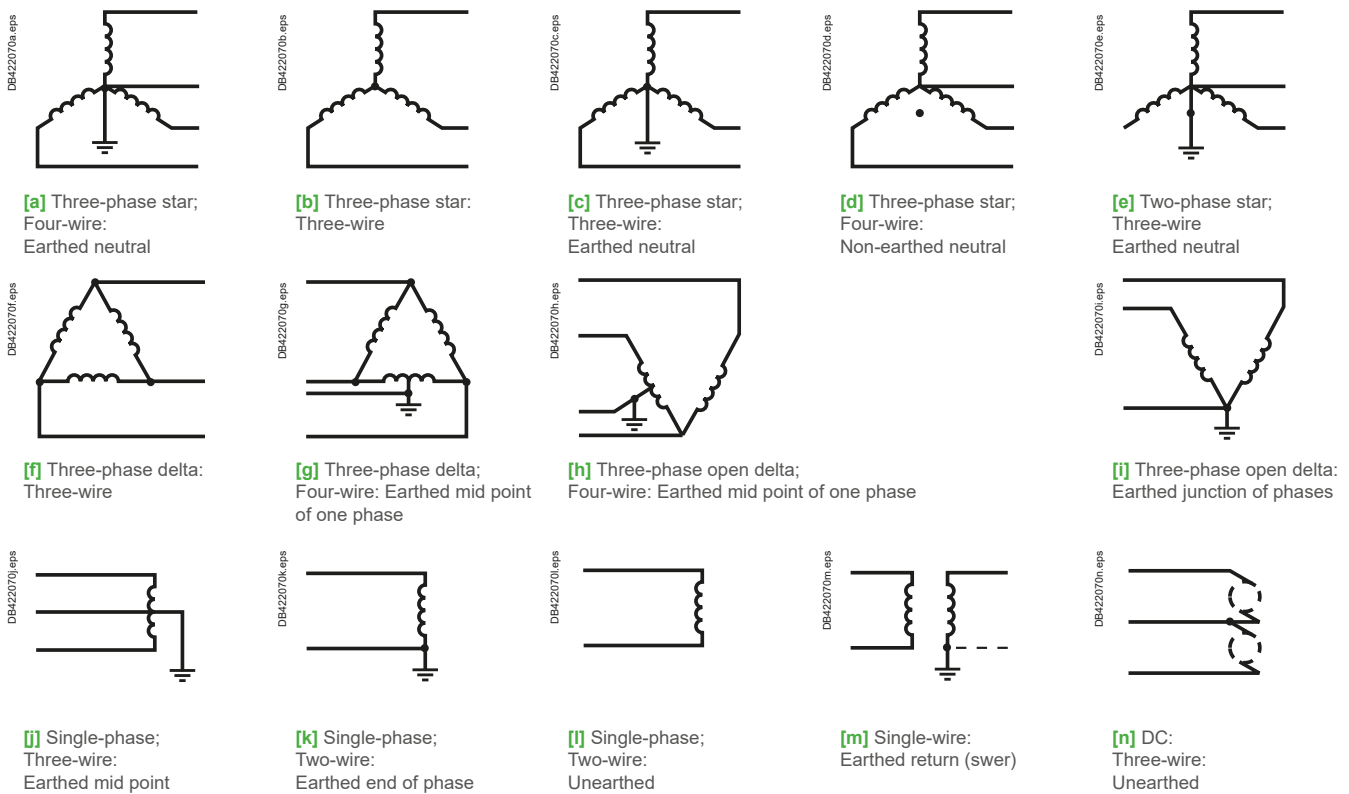


Fig. C2 Associated circuit diagrams

1 Low-voltage utility distribution networks

Residential and commercial consumers

The function of a LV “mains” distributor is to provide service connections (underground cable or overhead line) to a number of consumers along its route.

The current-rating requirements of distributors are estimated from the number of consumers to be connected and an average demand per consumer.

The two principal limiting parameters of a distributor are:

- The maximum current which it is capable of carrying indefinitely, and
- The maximum length of cable which, when carrying its maximum current, will not exceed the statutory voltage-drop limit

These constraints mean that the magnitude of loads which utilities are willing to connect to their LV distribution mains, is necessarily restricted.

For the range of LV systems mentioned in the second paragraph of this sub-clause (1.1) viz: 120 V single phase to 240/415 V 3-phase, typical maximum permitted loads connected to a LV distributor might^[1] be (see Fig. C3):

System	Assumed max. permitted current per consumer service	kVA
120 V 1-phase 2-wire	60 A	7.2
120/240 V 1-phase 3-wire	60 A	14.4
120/208 V 3-phase 4-wire	60 A	22
220/380 V 3-phase 4-wire	120 A	80
230/400 V 3-phase 4-wire	120 A	83
240/415 V 3-phase 4-wire	120 A	86

Fig. C3 Typical maximum permitted loads connected to a LV distributor

Practices vary considerably from one power supply organization to another, and no “standardized” values can be given.

Factors to be considered include:

- The size of an existing distribution network to which the new load is to be connected
- The total load already connected to the distribution network
- The location along the distribution network of the proposed new load, i.e. close to the substation, or near the remote end of the distribution network, etc

In short, each case must be examined individually.

The load levels listed above are adequate for all normal residential consumers, and will be sufficient for the installations of many administrative, commercial and similar buildings.

Medium-size and small industrial consumers (with dedicated LV lines direct from a utility supply MV/LV substation)

Medium and small industrial consumers can also be satisfactorily supplied at low-voltage.

For loads which exceed the maximum permitted limit for a service from a distributor, a dedicated cable can usually be provided from the LV distribution fuse- (or switch-) board, in the power utility substation.

Generally, the upper load limit which can be supplied by this means is restricted only by the available spare transformer capacity in the substation.

In practice, however:

- Large loads (e.g. > 300 kVA) require correspondingly large cables, so that, unless the load centre is close to the substation, this method can be economically unfavourable
- Many utilities prefer to supply loads exceeding 200 kVA (this figure varies with different suppliers) at medium voltage

For these reasons, dedicated supply lines at LV are generally applied (at 220/380 V to 240/415 V) to a load range of 80 kVA to 250 kVA.

Consumers normally supplied at low voltage include:

- Residential dwellings
- Shops and commercial buildings
- Small factories, workshops and filling stations
- Restaurants
- Farms, etc

[1] The Fig. C3 values shown are indicative only, being (arbitrarily) based on 60 A maximum service currents for the first three systems, since smaller voltage drops are allowed at these lower voltages, for a given percentage statutory limit. The second group of systems is (again, arbitrarily) based on a maximum permitted service current of 120 A.

1 Low-voltage utility distribution networks

C10

In cities and large towns, standardized LV distribution cables form a network through link boxes. Some links are removed, so that each (fused) distributor leaving a substation forms a branched open-ended radial system, as shown in Fig. C4

1.2 LV distribution networks

In European countries the standard 3-phase 4-wire distribution voltage level is 230/400 V. Many countries are currently converting their LV systems to the latest IEC standard of 230/400 V nominal (IEC 60038). Medium

to large-sized towns and cities have underground cable distribution systems.

MV/LV distribution substations, mutually spaced at approximately 500-600 metres, are typically equipped with:

- A 3- or 4-way MV switchboard, often made up of incoming and outgoing load-break switches forming part of a ring main, and one or two MV circuit breakers or combined fuse/ load-break switches for the transformer circuits
- One or two 1,000 kVA MV/LV transformers
- One or two (coupled) 6- or 8-way LV 3-phase 4-wire distribution fuse boards, or moulded-case circuit breaker boards, control and protect outgoing 4-core distribution cables, generally referred to as "distributors"

The output from a transformer is connected to the LV busbars via a load-break switch, or simply through isolating links.

In densely-loaded areas, a standard size of distributor is laid to form a network, with (generally) one cable along each pavement and 4-way link boxes located in manholes at street corners, where two cables cross.

Recent trends are towards weather-proof cabinets above ground level, either against a wall, or where possible, flush-mounted in the wall.

Links are inserted in such a way that distributors form radial circuits from the substation with open-ended branches (see Fig. C4). Where a link box unites a distributor from one substation with that from a neighbouring substation, the phase links are omitted or replaced by fuses, but the neutral link remains in place.

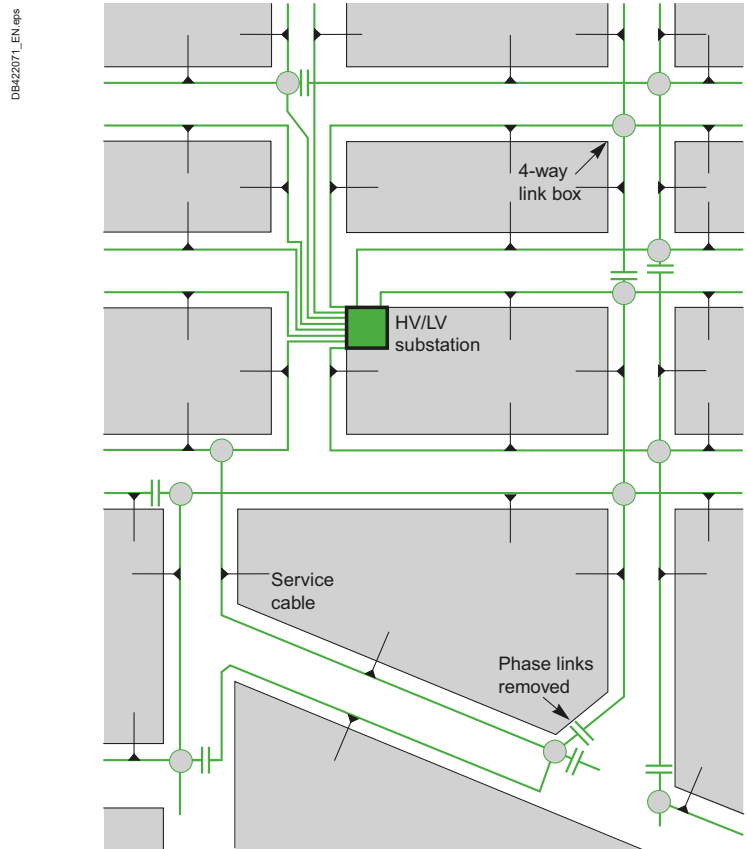


Fig. C4 Showing one of several ways in which a LV distribution network may be arranged for radial branched-distributor operation, by removing (phase) links

1 Low-voltage utility distribution networks

In less-densely loaded urban areas a more-economic system of tapered radial distribution is commonly used, in which conductors of reduced size are installed as the distance from a substation increases.

Improved methods using insulated twisted conductors to form a pole mounted aerial cable are now standard practice in many countries.

In Europe, each utility-supply distribution substation is able to supply at LV an area corresponding to a radius of approximately 300 metres from the substation.

North and Central American systems of distribution consist of a MV network from which numerous (small) MV/LV transformers each supply one or several consumers, by direct service cable (or line) from the transformer location.

Service components and metering equipment were formerly installed inside a consumer's building. The modern tendency is to locate these items outside in a weatherproof cabinet.

This arrangement provides a very flexible system in which a complete substation can be taken out of service, while the area normally supplied from it is fed from link boxes of the surrounding substations.

Moreover, short lengths of distributor (between two link boxes) can be isolated for fault-location and repair.

Where the load density requires it, the substations are more closely spaced, and transformers up to 1,500 kVA are sometimes necessary.

Other forms of urban LV network, based on free-standing LV distribution pillars, placed above ground at strategic points in the network, are widely used in areas of lower load density. This scheme exploits the principle of tapered radial distributors in which the distribution cable conductor size is reduced as the number of consumers downstream diminish with distance from the substation.

In this scheme a number of large-sectioned LV radial feeders from the distribution board in the substation supply the busbars of a distribution pillar, from which smaller distributors supply consumers immediately surrounding the pillar.

Distribution in market towns, villages and rural areas generally has, for many years, been based on bare copper conductors supported on wooden, concrete or steel poles, and supplied from pole-mounted or ground-mounted transformers.

In recent years, LV insulated conductors, twisted to form a two-core or 4-core self supporting cable for overhead use, have been developed, and are considered to be safer and visually more acceptable than bare copper lines.

This is particularly so when the conductors are fixed to walls (e.g. under-eaves wiring) where they are hardly noticeable.

As a matter of interest, similar principles have been applied at higher voltages, and self supporting "bundled" insulated conductors for MV overhead installations are now available for operation at 24 kV.

Where more than one substation supplies a village, arrangements are made at poles on which the LV lines from different substations meet, to interconnect corresponding phases.

North and Central American practice differs fundamentally from that in Europe, in that LV networks are practically nonexistent, and 3-phase supplies to premises in residential areas are rare.

The distribution is effectively carried out at medium voltage in a way, which again differs from standard European practices. The MV system is, in fact, a 3-phase 4-wire system from which single-phase distribution networks (phase and neutral conductors) supply numerous single-phase transformers, the secondary windings of which are centre-tapped to produce 120/240 V single-phase 3-wire supplies. The central conductors provide the LV neutrals, which, together with the MV neutral conductors, are solidly earthed at intervals along their lengths.

Each MV/LV transformer normally supplies one or several premises directly from the transformer position by radial service cable(s) or by overhead line(s).

Many other systems exist in these countries, but the one described appears to be the most common.

Fig. C5 (next page) shows the main features of the two systems.

1.3 The consumer-service connection

In the past, an underground cable service or the wall-mounted insulated conductors from an overhead line service, invariably terminated inside the consumer's premises, where the cable-end sealing box, the utility fuses (inaccessible to the consumer) and meters were installed.

A more recent trend is (as far as possible) to locate these service components in a weatherproof housing outside the building.

The utility/consumer interface is often at the outgoing terminals of the meter(s) or, in some cases, at the outgoing terminals of the installation main circuit breaker (depending on local practices) to which connection is made by utility staff, following a satisfactory test and inspection of the installation.

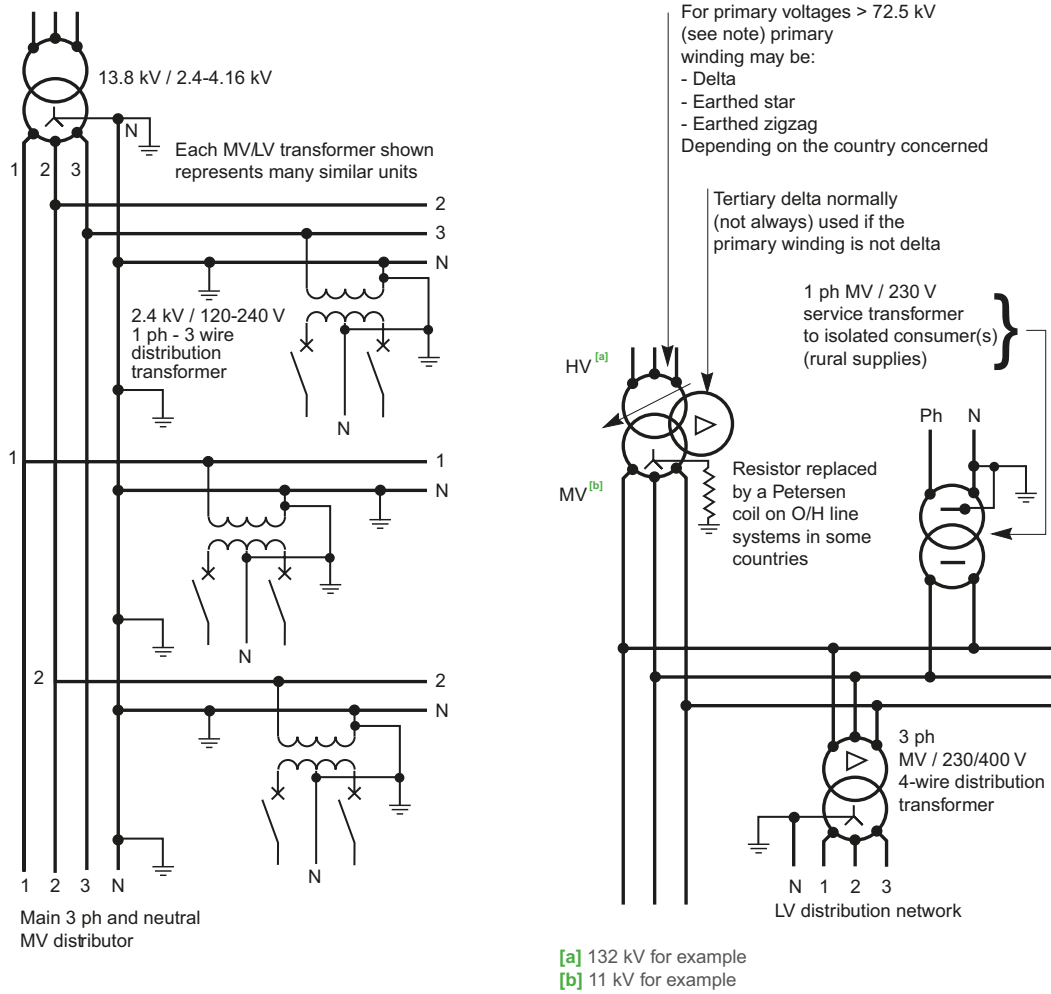
A typical arrangement is shown in **Fig. C6** (next page).

C - Connection to the LV utility distribution network

1 Low-voltage utility distribution networks

DB422072_EN.eps

C12



Note: At primary voltages greater than 72.5 kV in bulk-supply substations, it is common practice in some European countries to use an earthed-star primary winding and a delta secondary winding. The neutral point on the secondary side is then provided by a zigzag earthing reactor, the star point of which is connected to earth through a resistor. Frequently, the earthing reactor has a secondary winding to provide LV 3-phase supplies for the substation. It is then referred to as an “earthing transformer”.

Fig. C5 Widely-used American and European-type systems

DB422072_EN.eps

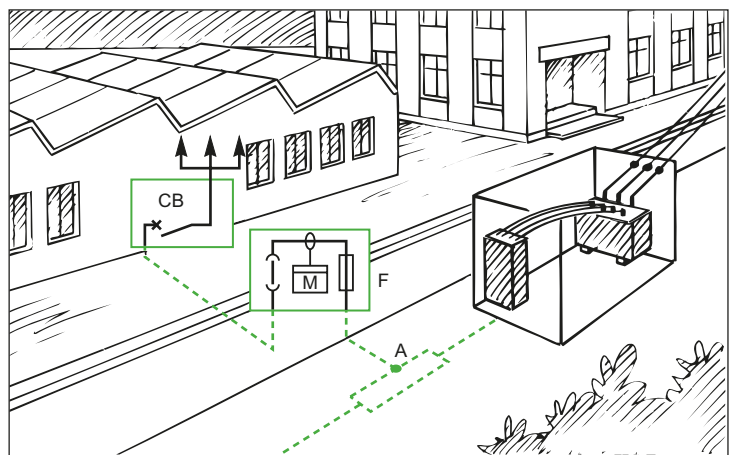


Fig. C6 Typical service arrangement for TT-earthed systems

1 Low-voltage utility distribution networks

LV consumers are normally supplied according to the TN or TT system, as described in chapters E and F. The installation main circuit breaker for a TT supply must include a residual current earth-leakage protective device. For a TN service, overcurrent protection by circuit breaker or switch-fuse is required.

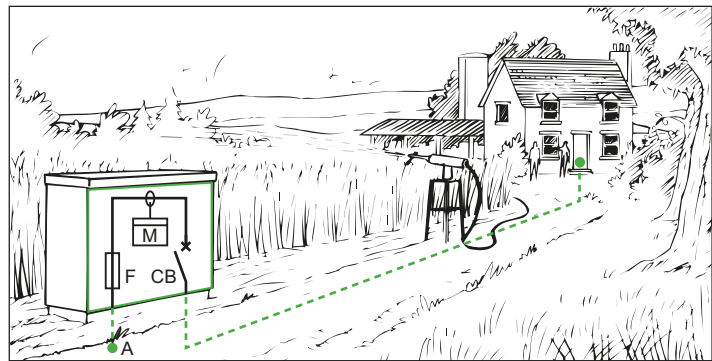
A MCCB -moulded case circuit breaker- which incorporates a sensitive residual-current earth-fault protective feature is mandatory at the origin of any LV installation forming part of a TT earthing system. The reason for this feature and related leakage-current tripping levels are discussed in Clause 4 of Chapter F.

A further reason for this MCCB is that the consumer cannot exceed his (contractual) declared maximum load, since the overload trip setting, which is sealed by the supply authority, will cut off supply above the declared value. Closing and tripping of the MCCB is freely available to the consumer, so that if the MCCB is inadvertently tripped on overload, or due to an appliance fault, supplies can be quickly restored following correction of the anomaly.

In view of the inconvenience to both the meter reader and consumer, the location of meters is nowadays generally outside the premises, either:

- In a free-standing pillar-type housing as shown in Fig. C7 and Fig. C8
- In a space inside a building, but with cable termination and supply authority's fuses located in a flush-mounted weatherproof cabinet accessible from the public way, as shown in Fig. C9 next page
- For private residential consumers, the equipment shown in the cabinet in Fig. C6 is installed in a weatherproof cabinet mounted vertically on a metal frame in the front garden, or flush-mounted in the boundary wall, and accessible to authorized personnel from the pavement. Fig. C10 (next page) shows the general arrangement, in which removable fuse links provide the means of isolation

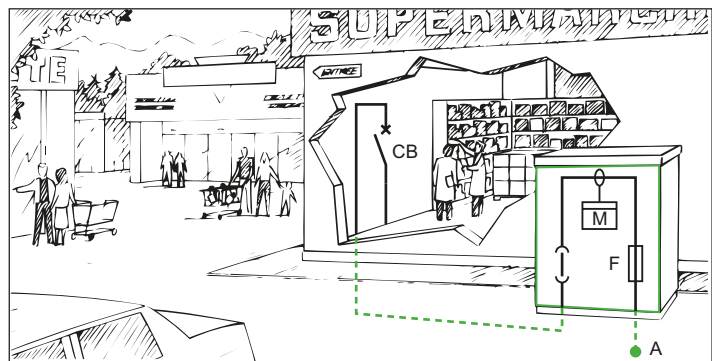
DB422074_EN.eps



In this kind of installation it is often necessary to place the main installation circuit breaker some distance from the point of utilization, e.g. saw-mills, pumping stations, etc.

Fig. C7 Typical rural-type installation

DB422075_EN.eps



The main installation CB is located in the consumer's premises in cases where it is set to trip if the declared kVA load demand is exceeded.

Fig. C8 Semi-urban installations (shopping precincts, etc.)

1 Low-voltage utility distribution networks



The service cable terminates in a flushmounted wall cabinet which contains the isolating fuse links, accessible from the public way. This method is preferred for esthetic reasons, when the consumer can provide a suitable metering and main-switch location.

Fig. C9 Town centre installations

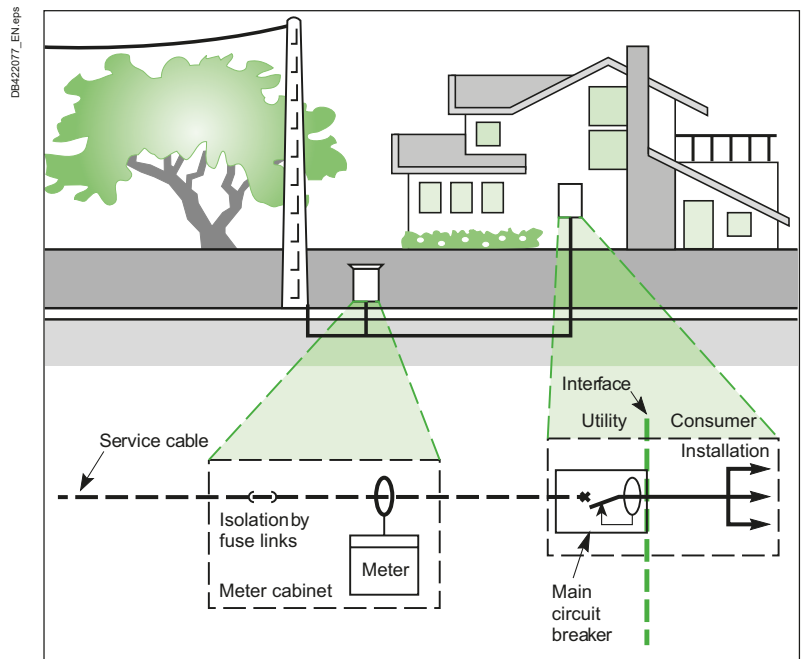


Fig. C10 Typical LV service arrangement for residential consumers

In the field of electronic metering, techniques have developed which make their use attractive by utilities either for electricity metering and for billing purposes, the liberalisation of the electricity market having increased the needs for more data collection to be returned from the meters. For example electronic metering can also help utilities to understand their customers' consumption profiles. In the same way, they will be useful for more and more power line communication and radio-frequency applications as well.

In this area, prepayment systems are also more and more employed when economically justified. They are based on the fact that for instance consumers having made their payment at vending stations, generate tokens to pass the information concerning this payment on to the meters. For these systems the key issues are security and inter-operability which seem to have been addressed successfully now. The attractiveness of these systems is due to the fact they not only replace the meters but also the billing systems, the reading of meters and the administration of the revenue collection.

1 Low-voltage utility distribution networks

An adequate level of voltage at the consumers supply-service terminals is essential for satisfactory operation of equipment and appliances. Practical values of current, and resulting voltage drops in a typical LV system, show the importance of maintaining a high Power Factor as a means of reducing voltage drop.

1.4 Quality of supply voltage

The quality of the LV network supply voltage in its widest sense implies:

- Compliance with statutory limits of magnitude and frequency
- Freedom from continual fluctuation within those limits
- Uninterrupted power supply, except for scheduled maintenance shutdowns, or as a result of system faults or other emergencies
- Preservation of a near-sinusoidal wave form

In this Sub-clause the maintenance of voltage magnitude only will be discussed.

In most countries, power-supply authorities have a statutory obligation to maintain the level of voltage at the service position of consumers within the limits of $\pm 5\%$ (or in some cases $\pm 6\%$ or more-see table C1) of the declared nominal value.

Again, IEC and most national standards recommend that LV appliances be designed and tested to perform satisfactorily within the limits of $\pm 10\%$ of nominal voltage. This leaves a margin, under the worst conditions (of minus 5% at the service position, for example) of 5% allowable voltage drop in the installation wiring.

The voltage drops in a typical distribution system occur as follows: the voltage at the MV terminals of a MV/LV transformer is normally maintained within a $\pm 2\%$ band by the action of automatic onload tapchangers of the transformers at bulk-supply substations, which feed the MV network from a higher-voltage subtransmission system.

If the MV/LV transformer is in a location close to a bulk-supply substation, the $\pm 2\%$ voltage band may be centered on a voltage level which is higher than the nominal MV value. For example, the voltage could be 20.5 kV $\pm 2\%$ on a 20 kV system. In this case, the MV/LV distribution transformer should have its MV off-circuit tapping switch selected to the + 2.5% tap position.

Conversely, at locations remote from bulk supply substations a value of 19.5 kV $\pm 2\%$ is possible, in which case the off-circuit tapping switch should be selected to the - 5% position.

The different levels of voltage in a system are normal, and depend on the system powerflow pattern. Moreover, these voltage differences are the reason for the term "nominal" when referring to the system voltage.

Practical application

With the MV/LV transformer correctly selected at its off-circuit tapping switch, an unloaded transformer output voltage will be held within a band of $\pm 2\%$ of its no-load voltage output.

To ensure that the transformer can maintain the necessary voltage level when fully loaded, the output voltage at no-load must be as high as possible without exceeding the upper + 5% limit (adopted for this example). In present-day practice, the winding ratios generally give an output voltage of about 104% at no-load [1], when nominal voltage is applied at MV, or is corrected by the tapping switch, as described above. This would result in a voltage band of 102% to 106% in the present case.

A typical LV distribution transformer has a short-circuit reactance voltage of 5%. If it is assumed that its resistance voltage is one tenth of this value, then the voltage drop within the transformer when supplying full load at 0.8 power factor lagging, will be:

$$\begin{aligned} V\% \text{ drop} &= R\% \cos \phi + X\% \sin \phi \\ &= 0.5 \times 0.8 + 5 \times 0.6 \\ &= 0.4 + 3 = 3.4\% \end{aligned}$$

The voltage band at the output terminals of the fully-loaded transformer will therefore be $(102 - 3.4) = 98.6\%$ to $(106 - 3.4) = 102.6\%$.

The maximum allowable voltage drop along a distributor is therefore $98.6 - 95 = 3.6\%$.

This means, in practical terms, that a medium-sized 230/400 V 3-phase 4-wire distribution cable of 240 mm² copper conductors would be able to supply a total load of 292 kVA at 0.8 PF lagging, distributed evenly over 306 metres of the distributor. Alternatively, the same load at the premises of a single consumer could be supplied at a distance of 153 metres from the transformer, for the same volt-drop, and so on...

As a matter of interest, the maximum rating of the cable, based on calculations derived from IEC 60287 (1982) is 290 kVA, and so the 3.6% voltage margin is not unduly restrictive, i.e. the cable can be fully loaded for distances normally required in LV distribution systems.

Furthermore, 0.8 PF lagging is appropriate to industrial loads. In mixed semi-industrial areas 0.85 is a more common value, while 0.9 is generally used for calculations concerning residential areas, so that the volt-drop noted above may be considered as a "worst case" example.

[1] Transformers designed for the 230/400 V IEC standard will have a no-load output of 420 V, i.e. 105% of the nominal voltage

2 Tariffs and metering

C16

No attempt will be made in this guide to discuss particular tariffs, since there appears to be as many different tariff structures around the world as there are utilities.

Some tariffs are very complicated in detail but certain elements are basic to all of them and are aimed at encouraging consumers to manage their power consumption in a way which reduces the cost of generation, transmission and distribution.

The two predominant ways in which the cost of supplying power to consumers can be reduced, are:

- Reduction of power losses in the generation, transmission and distribution of electrical energy. In principle the lowest losses in a power system are attained when all parts of the system operate at unity power factor
- Reduction of the peak power demand, while increasing the demand at low-load periods, thereby exploiting the generating plant more fully, and minimizing plant redundancy.

Reduction of losses

Although the ideal condition noted in the first possibility mentioned above cannot be realized in practice, many tariff structures are based partly on kVA demand, as well as on kWh consumed. Since, for a given kW loading, the minimum value of kVA occurs at unity power factor, the consumer can minimize billing costs by taking steps to improve the power factor of the load (as discussed in Chapter L).

The kVA demand generally used for tariff purposes is the maximum average kVA demand occurring during each billing period, and is based on average kVA demands, over fixed periods (generally 10, 30 or 60 minute periods) and selecting the highest of these values. The principle is described below in "principle of kVA maximum-demand metering".

Reduction of peak power demand

The second aim, i.e. that of reducing peak power demands, while increasing demand at low-load periods, has resulted in tariffs which offer substantial reduction in the cost of energy at:

- Certain hours during the 24-hour day
- Certain periods of the year.

The simplest example is that of a residential consumer with a storage-type water heater (or storage-type space heater, etc.). The meter has two digital registers, one of which operates during the day and the other (switched over by a timing device) operates during the night. A contactor, operated by the same timing device, closes the circuit of the water heater, the consumption of which is then indicated on the register to which the cheaper rate applies. The heater can be switched on and off at any time during the day if required, but will then be metered at the normal rate. Large industrial consumers may have 3 or 4 rates which apply at different periods during a 24-hour interval, and a similar number for different periods of the year. In such schemes the ratio of cost per kWh during a period of peak demand for the year, and that for the lowest-load period of the year, may be as much as 10: 1.

Meters

It will be appreciated that high-quality instruments and devices are necessary to implement this kind of metering, when using classical electro-mechanical equipment. Recent developments in electronic metering and micro-processors, together with remote ripple-control [1] from an utility control centre (to change peak-period timing throughout the year, etc.) are now operational, and facilitate considerably the application of the principles discussed.

In most countries, some tariffs, as noted above, are partly based on kVA demand, in addition to the kWh consumption, during the billing periods (often 3-monthly intervals). The maximum demand registered by the meter to be described, is, in fact, a maximum (i.e. the highest) average kVA demand registered for succeeding periods during the billing interval.

[1] Ripple control is a system of signalling in which a voice frequency current (commonly at 175 Hz) is injected into the LV mains at appropriate substations. The signal is injected as coded impulses, and relays which are tuned to the signal frequency and which recognize the particular code will operate to initiate a required function. In this way, up to 960 discrete control signals are available.

2 Tariffs and metering

Fig. C11 shows a typical kVA demand curve over a period of two hours divided into succeeding periods of 10 minutes. The meter measures the average value of kVA during each of these 10 minute periods.

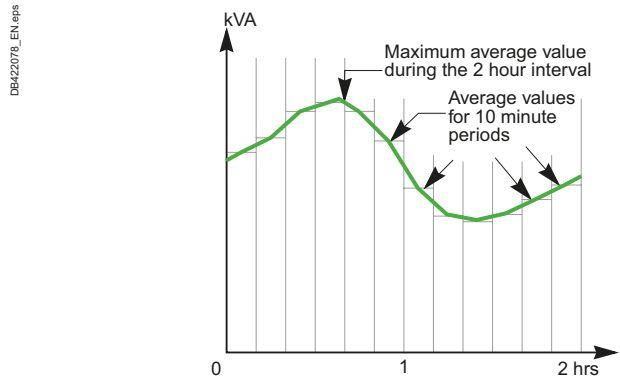


Fig. C11 Maximum average value of kVA over an interval of 2 hours

Principle of kVA maximum demand metering

A kVAh meter is similar in all essentials to a kWh meter but the current and voltage phase relationship has been modified so that it effectively measures kVAh (kilo-volt-ampere-hours). Furthermore, instead of having a set of decade counter dials, as in the case of a conventional kWh meter, this instrument has a rotating pointer. When the pointer turns it is measuring kVAh and pushing a red indicator before it. At the end of 10 minutes the pointer will have moved part way round the dial (it is designed so that it can never complete one revolution in 10 minutes) and is then electrically reset to the zero position, to start another 10 minute period. The red indicator remains at the position reached by the measuring pointer, and that position, corresponds to the number of kVAh (kilo-volt-ampere-hours) taken by the load in 10 minutes. Instead of the dial being marked in kVAh at that point however it can be marked in units of average kVA. The following figures will clarify the matter.

Supposing the point at which the red indicator reached corresponds to 5 kVAh. It is known that a varying amount of kVA of apparent power has been flowing for 10 minutes, i.e. 1/6 hour.

If now, the 5 kVAh is divided by the number of hours, then the average kVA for the period is obtained.

In this case the average kVA for the period will be:

$$5 \times \frac{1}{\frac{1}{6}} = 5 \times 6 = 30 \text{ kVA}$$

Every point around the dial will be similarly marked i.e. the figure for average kVA will be 6 times greater than the kVAh value at any given point. Similar reasoning can be applied to any other reset-time interval.

At the end of the billing period, the red indicator will be at the maximum of all the average values occurring in the billing period.

The red indicator will be reset to zero at the beginning of each billing period. Electro-mechanical meters of the kind described are rapidly being replaced by electronic instruments. The basic measuring principles on which these electronic meters depend however, are the same as those described above.

C - Connection to the LV utility distribution network

C18

1	<u>Stakes of architecture design</u>	D2
2	<u>Simplified architecture design process</u>	D3
	2.1 The architecture design	D3
	2.2 The whole process	D4
3	<u>Electrical installation characteristics</u>	D6
4	<u>Technological characteristics</u>	D10
5	<u>Architecture assessment criteria</u>	D11
6	<u>Choice of architecture fundamentals</u>	D13
	6.1 Connection to the utility network	D13
	6.2 Internal MV circuits	D15
	6.3 Number and localisation of MV/LV transformer substations	D16
	6.4 Number of MV/LV transformers	D16
	6.5 MV back-up generator	D16
7	<u>Choice of architecture details</u>	D17
	7.1 Layout	D17
	7.2 Centralized or distributed layout of LV distribution	D18
	7.3 Presence of LV back-up generators	D20
	7.4 Presence of an Uninterruptible Power Supply (UPS)	D21
8	<u>Choice of equipment</u>	D24
9	<u>Recommendations for architecture optimization</u>	D25
10	<u>Glossary</u>	D29
11	<u>Example: electrical installation in a printworks</u>	D30

1 Stakes of architecture design

D2

Choice of distribution architecture

This chapter is dedicated to electrical architecture design for medium and large buildings. Despite the various types of buildings (office, hotel, industrial, collective housing, etc.) the stakes for electrical design rely on a key process with practical considerations described in this chapter.

The choice of distribution architecture has a decisive impact on installation performance throughout its lifecycle:

- right from the construction phase, choices can greatly influence the installation time, possibilities of work rate, required competencies of installation teams, etc.
- there will also be an impact on performance during the operation phase in terms of quality and continuity of power supply to sensitive loads, power losses in power supply circuits,
- and lastly, there will be an impact on the proportion of the installation that can be recycled in the end-of-life phase.

The Electrical Distribution architecture of an installation involves the spatial configuration, the choice of power sources, the definition of different distribution levels, the single-line diagram and the choice of equipment.

The choice of the best architecture is often expressed in terms of seeking a compromise between the various performance criteria that interest the customer who will use the installation at different phases in its lifecycle. The earlier we search for solutions, the more optimization possibilities exist (see **Fig. D1**).

These topics are now part of IEC60364 standard in chapter 8 (IEC 60364-8-1: Low voltage electrical installations - Energy Efficiency).

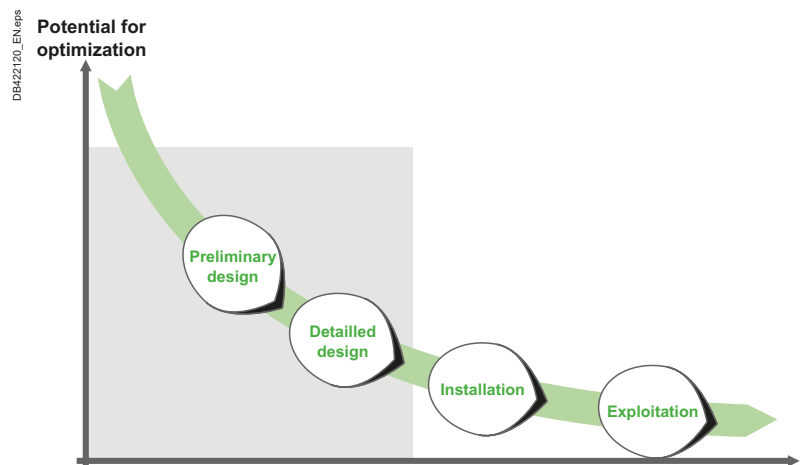


Fig. D1 Optimization potential

A successful search for an optimal solution is also strongly linked to the ability for exchange between the various players involved in designing the various sections of a project:

- the architect who defines the organization of the building according to user requirements,
- the designers of different technical sections (lighting, heating, air conditioning, fluids, etc.),
- the user's representatives e.g. defining the process.

The following paragraphs present the selection criteria as well as the architecture design process to meet the project performance criteria in the context of industrial and tertiary buildings (excluding large sites).

2 Simplified architecture design process

2.1 The architecture design

The architecture design considered in this document starts at the preliminary design stage (see Fig. D3 step1). It generally covers the levels of MV/LV main distribution, LV power distribution, and exceptionally the terminal distribution level. (see Fig. D2).

In buildings all consumers are connected in low voltage. It means that MV distribution consists in:

- connection to utility,
- distribution to MV/LV substation(s),
- MV/LV substation(s) itself.

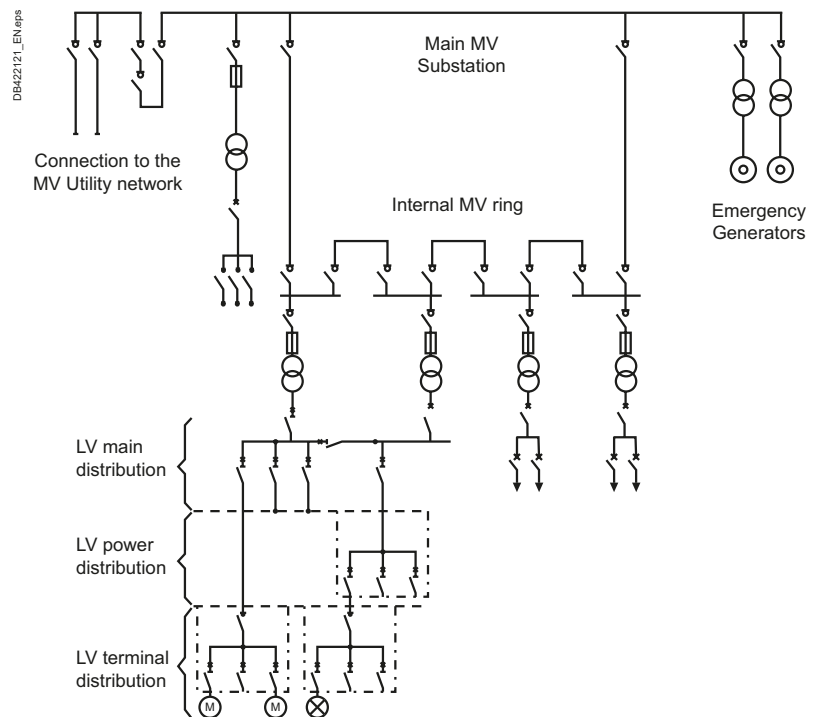


Fig. D2 Example of single-line diagram

The design of an electrical distribution architecture can be described by a 3-stage process, with iterative possibilities. This process is based on taking into account the installation characteristics and criteria to be satisfied.

D - MV & LV architecture selection guide for buildings

2 Simplified architecture design process

2.2 The whole process

The whole process is described briefly in the following paragraphs and illustrated on **Fig. D3**.

The process described in this document is not intended as the only solution. This document is a guide intended for the use of electrical installation designers.

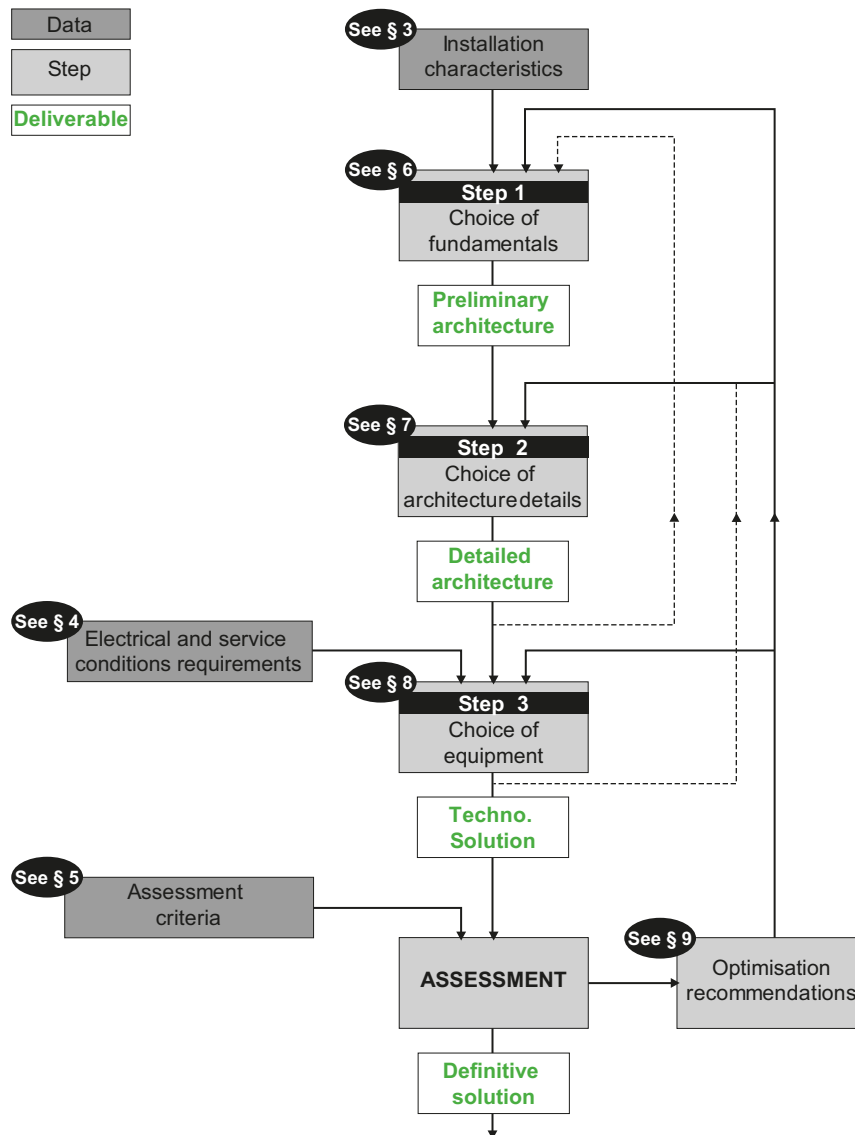


Fig. D3 Flow diagram for choosing the electrical distribution architecture

Step 1: Choice of distribution architecture fundamentals

This involves defining the general features of the electrical installation. It is based on taking into account the macroscopic characteristics concerning the installation and its usage.

These characteristics have an impact on the connection to the upstream network, MV circuits, the number of MV/LV substation, etc.

At the end of this step, we may have several distribution schematic diagram solutions, which are used as a starting point for the single-line diagram. The definitive choice is confirmed at the end of the step 2.

2 Simplified architecture design process

Step 2: choice of architecture details

This involves defining the electrical installation in more detail. It is based on the results of the previous step, as well as on satisfying criteria relative to implementation and operation of the installation.

The process loops back into step1 if the criteria are not satisfied. An iterative process allows several assessment criteria combinations to be analyzed. At the end of this step, we have a detailed single-line diagram.

Step 3: choice of equipment

The choice of equipment to be implemented is carried out in this stage, and results from the choice of architecture. The choices are made from the manufacturer catalogues, in order to satisfy electrical requirements and service conditions. This stage is looped back into step 2 if the characteristics are not satisfied.

Assessment

This assessment step allows the design office to have figures as a basis for discussions with the customer and other players.

According to the result of these discussions, it may be possible to loop back into steps 1, 2 or 3.

3 Electrical installation characteristics

These are the main installation characteristics enabling the defining of the fundamentals and details of the electrical distribution architecture. For each of these characteristics, we supply a definition and the different categories or possible values.

3.1 Sectors of activities

Definition:

Among the definitions proposed by IEC60364-8-1 § 3.4, mainly those listed below are part of this chapter.

Residential buildings

- Premises designed and constructed for private habitation

Commercial

- Premises designed and constructed for commercial operations ^[1]

Industry

- Premises designed and constructed for manufacturing and processing of operations ^[2]

Infrastructure

- Systems or premises designed and constructed for the transport and utility operation ^[3]

3.2 Site topology

Definition:

Architectural characteristic of the building(s), taking into account the number of buildings, number of floors, and of the surface area of each floor.

Different categories:

- Single storey building,
- Multi-storey building,
- Multi-building site,
- High-rise building.

3.3 Layout latitude

Definition:

Characteristic taking into account the constraints in terms of the layout of the electrical equipment in the building:

- aesthetics,
- accessibility,
- presence of dedicated locations,
- use of technical corridors (per floor),
- use of technical ducts (vertical).

Different categories:

- Low: the position of the electrical equipment is virtually imposed
- Medium: the position of the electrical equipment is partially imposed, to the detriment of the criteria to be satisfied
- High: no constraints. The position of the electrical equipment can be defined to best satisfy the criteria.

[1] Examples of commercial building: offices, retail, distribution, public buildings, banks, hotels.

[2] Examples of industrial buildings: factories, workshops, distribution centers.

[3] Examples of infrastructure: airport, harbours, rails, transport facilities.

3 Electrical installation characteristics

3.4 Service reliability

Definition:

The ability of a power system to meet its supply function under stated conditions for a specified period of time.

Different categories:

- Minimum: this level of service reliability implies risk of interruptions related to constraints that are geographical (separate network, area distant from power production centers), technical (overhead line, poorly meshed system), or economic (insufficient maintenance, under-dimensioned generation).
- Standard
- Enhanced: this level of service reliability can be obtained by special measures taken to reduce the probability of interruption (underground network, strong meshing, dedicated architectures, emergency generators, etc.)

D7

3.5 Maintainability

Definition:

Features input during design to limit the impact of maintenance actions on the operation of the whole or part of the installation.

Different categories:

- Minimum: the installation must be stopped to carry out maintenance operations.
- Standard: maintenance operations can be carried out during installation operations, but with deteriorated performance. These operations must be preferably scheduled during periods of low activity. Example: several transformers with partial redundancy and load shedding.
- Enhanced: special measures are taken to allow maintenance operations without disturbing the installation operations. Example: double-ended configuration.

3.6 Installation flexibility

Definition:

Possibility of easily moving electricity delivery points within the installation, or to easily increase the power supplied at certain points. Flexibility is a criterion which also appears due to the uncertainty of the building during the pre-project summary stage.

Different categories:

- No flexibility: the position of loads is fixed throughout the lifecycle, due to the high constraints related to the building construction or the high weight of the supplied process. E.g.: smelting works.
 - Flexibility of design: the number of delivery points, the power of loads or their location are not precisely known.
 - Implementation flexibility: the loads can be installed after the installation is commissioned.
 - Operating flexibility: the position of loads will fluctuate, according to process re-organization.
- Examples:
- industrial building: extension, splitting and changing usage
 - office building: splitting

3.7 Power demand

Definition:

It's the maximum power and apparent power demands actually required to dimension the installation (see chapter A section 4 for more information):

- < 630kVA
- from 630 to 1250kVA
- from 1250 to 2500kVA
- > 2500kVA

3.8 Load distribution

Definition:

A characteristic related to the uniformity of load distribution (in kVA / m²) over an area or throughout the building.

Different categories:

- Uniform distribution: the loads are generally of an average or low unit power and spread throughout the surface area or over a large area of the building (uniform density).
E.g.: lighting, individual workstations
- intermediate distribution: the loads are generally of medium power, placed in groups over the whole building surface area
E.g.: machines for assembly, conveying, workstations, modular logistics "sites"
- localized loads: the loads are generally high power and localized in several areas of the building (non-uniform density).
E.g.: HVAC

3.9 Voltage Interruption Sensitivity

Definition:

The aptitude of a circuit to accept a power interruption.

Different categories:

- "Sheddable" circuit: possible to shut down at any time for an indefinite duration
- Long interruption acceptable: interruption time > 3 minutes *
- Short interruption acceptable: interruption time < 3 minutes *
- No interruption acceptable.

We can distinguish various levels of severity of an electrical power interruption, according to the possible consequences:

- No notable consequence,
- Loss of production,
- Deterioration of the production facilities or loss of sensitive data,
- Causing mortal danger.

This is expressed in terms of the criticality of supplying of loads or circuits.

- Non-critical:

The load or the circuit can be "shed" at any time. E.g.: sanitary water heating circuit.

- Low criticality:

A power interruption causes temporary discomfort for the occupants of a building, without any financial consequences. Prolonging of the interruption beyond the critical time can cause a loss of production or lower productivity. E.g.: heating, ventilation and air conditioning circuits (HVAC).

- Medium criticality

A power interruption causes a short break in process or service. Prolonging of the interruption beyond a critical time can cause a deterioration of the production facilities or a cost of starting for starting back up.

E.g.: refrigerated units, lifts.

- High criticality

Any power interruption causes mortal danger or unacceptable financial losses. E.g.: operating theatre, IT department, security department.

* indicative value, supplied by standard EN50160:
"Characteristics of the voltage supplied by public distribution networks".

3 Electrical installation characteristics

3.10 Disturbance sensitivity

Definition

The ability of a circuit to work correctly in presence of an electrical power disturbance.

A disturbance can lead to varying degrees of malfunctioning. E.g.: stopping working, incorrect working, accelerated ageing, increase of losses, etc

Types of disturbances with an impact on circuit operations:

- overvoltages
- voltage harmonic distortion,
- voltage drop, voltage dip
- voltage fluctuation,
- voltage imbalance.

Different categories:

- low sensitivity: disturbances in supply voltages have very little effect on operations.
E.g.: heating device.
- medium sensitivity: voltage disturbances cause a notable deterioration in operations.
E.g.: motors, lighting.
- high sensitivity: voltage disturbances can cause operation stoppages or even the deterioration of the supplied equipment.
E.g.: IT equipment.

The sensitivity of circuits to disturbances determines the design of shared or dedicated power circuits. Indeed it is better to separate “sensitive” loads from “disturbing” loads. E.g.: separating lighting circuits from motor supply circuits. This choice also depends on operating features. E.g.: separate power supply of lighting circuits to enable measurement of power consumption.

3.11 Disturbance potential of circuits

Definition

The ability of a circuit to disturb the operation of surrounding circuits due to phenomena such as: harmonics, in-rush current, imbalance, High Frequency currents, electromagnetic radiation, etc.

Different categories

- Non disturbing: no specific precaution to take
- moderate or occasional disturbance: separate power supply may be necessary in the presence of medium or high sensitivity circuits. E.g.: lighting circuit generating harmonic currents.
- Very disturbing: a dedicated power circuit or ways of attenuating disturbances are essential for the correct functioning of the installation. E.g.: electrical motor with a strong start-up current, welding equipment with fluctuating current.

3.12 Other considerations or constraints

- Specific rules
E.g.: hospitals, high rise buildings, etc.
- Rule of the Energy Distributor
Example: limits of connection power for LV, access to MV substation, etc
- Attachment loads
Loads attached to 2 independent circuits for reasons of redundancy.
- Designer experience
Consistency with previous designs or partial usage of previous designs, standardization of sub-assemblies, existence of an installed equipment base.
- Load power supply constraints
Voltage level (230V, 400V, 690V), voltage system (single-phase, three-phase with or without neutral, etc)

4 Technological characteristics

The technological solutions considered concern the various types of MV and LV equipment, as well as Busbar Trunking Systems .

The choice of technological solutions is made following the choice of single-line diagram and according to characteristics given below.

4.1 Environment, atmosphere

A notion taking into account all of the environmental constraints (average ambient temperature, altitude, humidity, corrosion, dust, impact, etc.) and bringing together protection indexes IP and IK.

Different categories:

- Standard: no particular environmental constraints
- Enhanced: severe environment, several environmental parameters generate important constraints for the installed equipment
- Specific: atypical environment, requiring special enhancements

4.2 Service Index

The Service Index (IS), is a tool dedicated to electrical designers in order to specify LV switchboards with reference to user's need rather than to technical aspects. It ensures the effective definition of the switchboards according to IEC61439-1 and 2 criteria for any:

- future evolution,
- maintenance,
- operation needs.

IS have been defined by the french standard committee (AFNOR/UTE) in 2002 under the reference C63-429.

The IS is characted by 3 numbers from 1 to 3, reflecting respectively:

- level of operation needs,
- level of maintenance request,
- level of evolution request.

The levels are described in **Fig. D4**

	Operation ^[a] : first number	Maintenance ^[b] : second number	Evolution ^[c] : third number
Level 1	Full shutdown of the switchboard is accepted	Full shutdown of the switchboard is accepted	Full shutdown of the switchboard is accepted
Level 2	Only shut down of the concerned functional unit ^[d] is accepted	Only shutdown of the concerned functional unit ^[d] is accepted. But reconnection of the functional unit requests an action on connections	Only shutdown of the concerned functional unit ^[d] is accepted. Spare functional units are provided
Level 3	Only the shutdown of the power of the functional unit ^[d] is accepted (control circuits are still available)	Only shutdown of the concerned functional unit ^[d] is accepted. Reconnection of the functional unit requests no action on connections	Only shutdown of the concerned functional unit ^[d] is accepted. Evolution does not request pre-equipped spare functional units.

[a] Operation: set of actions on the switchboard, which can be done by non-electrician people.

[b] Maintenance: concerns action of control, diagnostic, servicing, repairation, refurbishment, made by professionals.

[c] Evolution: adaptation of the equipment by addition of devices, increase of power demand.

[d] Functional unit: subset of a LV switchboard including all mechanical and electrical parts dedicated to a specific function like : incomer, main feeder, auxiliary, etc.

Fig. D4 Definition of Service Index values

4.3 Other considerations

Other considerations have an impact on the choice of technological solutions:

- Previous experience,
- Consistency with past designs or the partial use of past designs,
- Standardization of sub-assemblies,
- The existence of an installed equipment base,
- Utilities requirements,
- Technical criteria: target power factor, backed-up load power, presence of harmonic generators...

These considerations should be taken into account during the detailed electrical definition phase following the draft design stage.

5 Architecture assessment criteria

Certain decisive criteria are assessed at the end of the 3 stages in defining architecture, in order to validate the architecture choice. These criteria are listed below with the different allocated levels of priority.

5.1 On-site work time

Time for implementing the electrical equipment on the site.

Different levels of priority:

- Standard: the on-site work time can be extended, if this gives a reduction in overall installation costs,
- Special: the on-site work time must be minimized, without generating any significant excess cost,
- Critical: the on-site work time must be reduced as far as possible, imperatively, even if this generates a higher total installation cost,

D11

5.2 Environmental impact

Taking into consideration environmental constraints in the installation design. This takes into account the: consumption of natural resources, Joule losses (related to CO₂ emission), "recyclability" potential, throughout the installation's lifecycle.

Different levels of priority:

- Non significant: environmental constraints are not given any special consideration,
- Minimal: the installation is designed with minimum regulatory requirements,
- Proactive: the installation is designed with a specific concern for protecting the environment (low energy building, green buildings, etc.).

The environmental impact of an installation will be determined according to the method carrying out an installation lifecycle analysis, in which we distinguish between the following 3 phases:

- construction,
- operation,
- end of life (dismantling, recycling).

In terms of environmental impact, 3 indicators (at least) can be taken into account and influenced by the design of an electrical installation. Although each lifecycle phase contributes to the three indicators, each of these indicators is mainly related to one phase in particular:

- Manufacturing phase mainly impact the consumption of natural resources (steel, copper, aluminium),
- Operation phase impacts mainly the energy consumption (power losses cumulated during all the operating period).
- End of life is mainly impacted by the recyclability potential of equipment and material (presence of hazardous material, quantity of insulation material).

The following table details the contributing factors to the 3 environmental indicators (Fig. D5).

Indicators	Contributors
Natural resources consumption	Mass and type of conductor material: copper, steel, aluminium
Power consumption	Joule losses in conductors, transformers, no-load losses of transformers
"Recyclability" potential	Mass and type of insulation material, presence of hazardous material.

Fig. D5 Contributing factors to the 3 environmental indicators

5 Architecture assessment criteria

D12

5.3 Preventive maintenance level

Definition:

Number of hours and sophistication of maintenance carried out during operations in conformity with manufacturer recommendations to ensure dependable operation of the installation and the maintaining of performance levels (avoiding failure: tripping, down time, etc).

Different categories:

- Standard: according to manufacturer recommendations.
- Enhanced: according to manufacturer recommendations, with a severe environment,
- Specific: specific maintenance plan, meeting high requirements for continuity of service, and requiring a high level of maintenance staff competency.

5.4 Availability of electrical power supply

Definition:

This is the probability that an electrical installation be capable of supplying quality power in conformity with the specifications of the equipment it is supplying. This is expressed by an availability level:

$$\text{Availability (\%)} = (1 - \text{MTTR} / \text{MTBF}) \times 100$$

MTTR (Mean Time To Repair): the average time to make the electrical system once again operational following a failure (this includes detection of the reason for failure, its repair and re-commissioning),

MTBF (Mean Time Between Failure): measurement of the average time for which the electrical system is operational and therefore enables correct operation of the application.

The different availability categories can only be defined for a given type of installation. E.g.: hospitals, data centers.

Example of classification used in data centers:

Tier 1: the power supply and air conditioning are provided by one single channel, without redundancy, which allows availability of 99.671%,

Tier 2: the power supply and air conditioning are provided by one single channel, with redundancy, which allows availability of 99.741%,

Tier 3: the power supply and air conditioning are provided by several channels, with one single redundant channel, which allows availability of 99.982%,

Tier 4: the power supply and air conditioning are provided by several channels, each with redundancy, which allows availability of 99.995%.

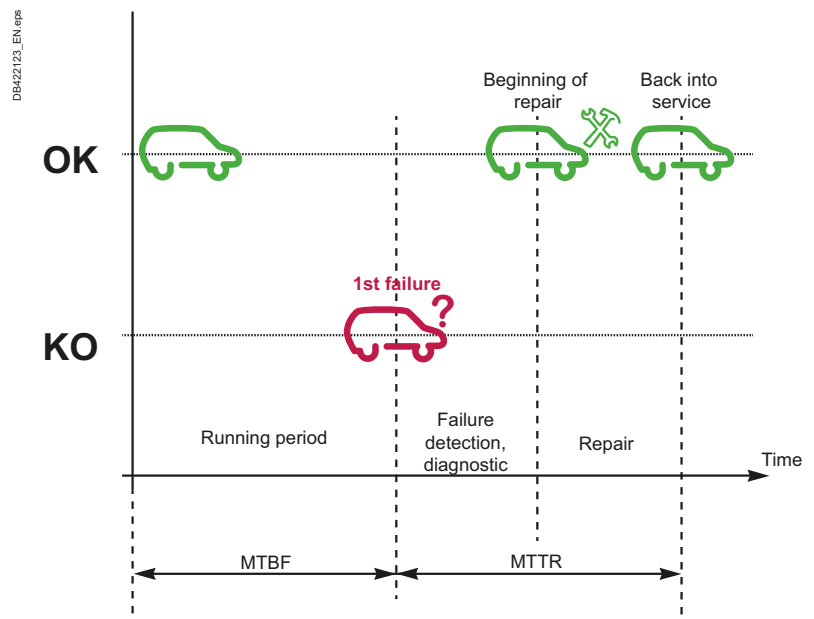


Fig. D6 Definition of MTBF and MTTR

6 Choice of architecture fundamentals

For the installations considered in this guide, the selection of an electrical architecture can be performed in two stages.

- The first stage is generally dedicated to:
 - The selection of the mode of connection of the installation to the utility network,
 - The choice of the internal MV distribution including:
 - The definition of the number of MV/LV substations,
 - The definition of the number of MV/LV transformers,
 - The definition of the MV back-up generator when needed.
- The second stage deals with the principle of supply of the LV consumers

6.1 Connection to the utility network

The possible solutions for the connection of an installation to the utility network are the following:

- Connection to the LV network for small and medium size installations requiring less than 400 kVA. Fixing this limit is always under the responsibility of the local utility managing the LV network
- Above this previous limit, connection to the MV network with either LV or MV metering.

LV metering is generally authorized for installation including a single MV/LV transformer not exceeding the rated power limit fixed by the utility, generally around 1250 kVA.

The possible connections to a MV utility network are the following, (see [Fig. D8](#), [Fig. D9](#) and [Fig. D10](#)):

- MV single-line service,
- MV ring-main service,
- MV duplicate supply service, including two load break switches equipped with an automatic change over,
- MV dual supply service with two independent connections to the utility and two bus bars connected with a bus tie. The two utility incomers and the bus tie are equipped with an automatic change over.

Comparison of this four modes of connection are summarized in [Fig. D7](#)

Characteristic to consider	Configuration				
	LV	MV			
		Single-line	Ring-main	Duplicate supply	Dual supply
Activity	Any	Any	Any	High tech, sensitive office, health-care	Very sensitive installations
Site topology	Single building	Single building	Single or several buildings	Single or several buildings	Single or several buildings
Service reliability	Minimal	Minimal	Standard	Enhanced	Very high
Power demand	< 400 kVA	≤ 1250kVA	Any	Any	Any
Other connection constraints	Any	Isolated site	Low density urban area	High density urban area	Dedicated measures taken by the utility

Fig. D7 Comparison of the modes of connection

6 Choice of architecture fundamentals

D14

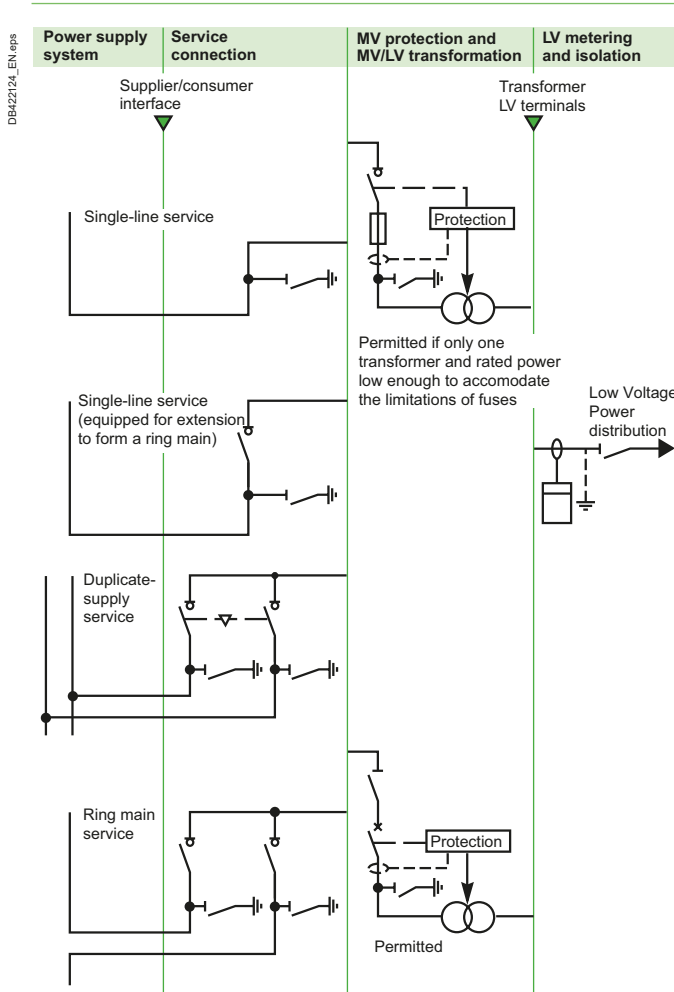


Fig. D8 MV connection with LV metering

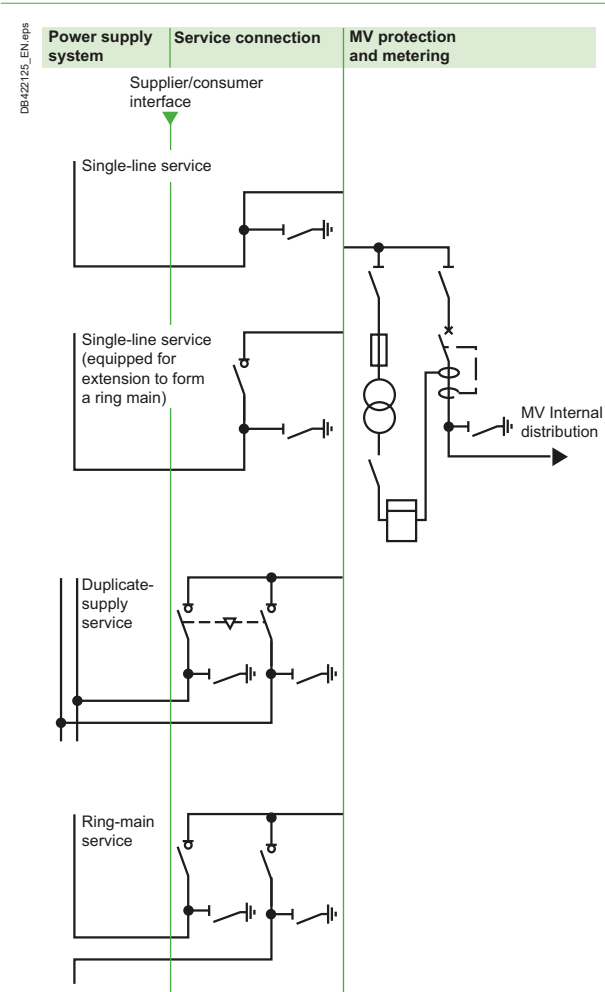


Fig. D9 MV connection with MV metering

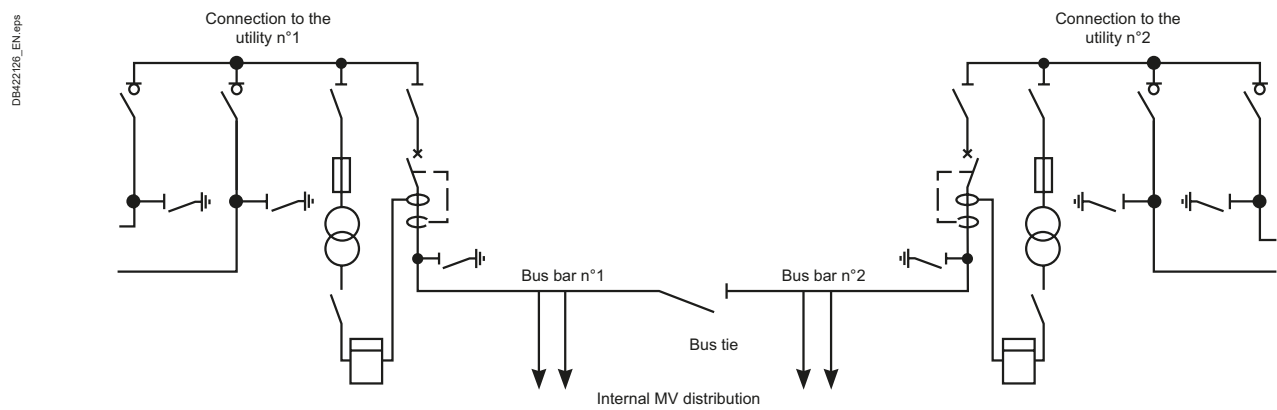


Fig. D10 Dual MV connection with MV metering

6.2 Internal MV circuits

Internal MV circuits are dedicated to the supply of the secondary MV/LV substations dispersed in the installation. They are three typical principles commonly used for this purpose (Fig. D11):

- Single feeder
- Dual feeder
- Open ring

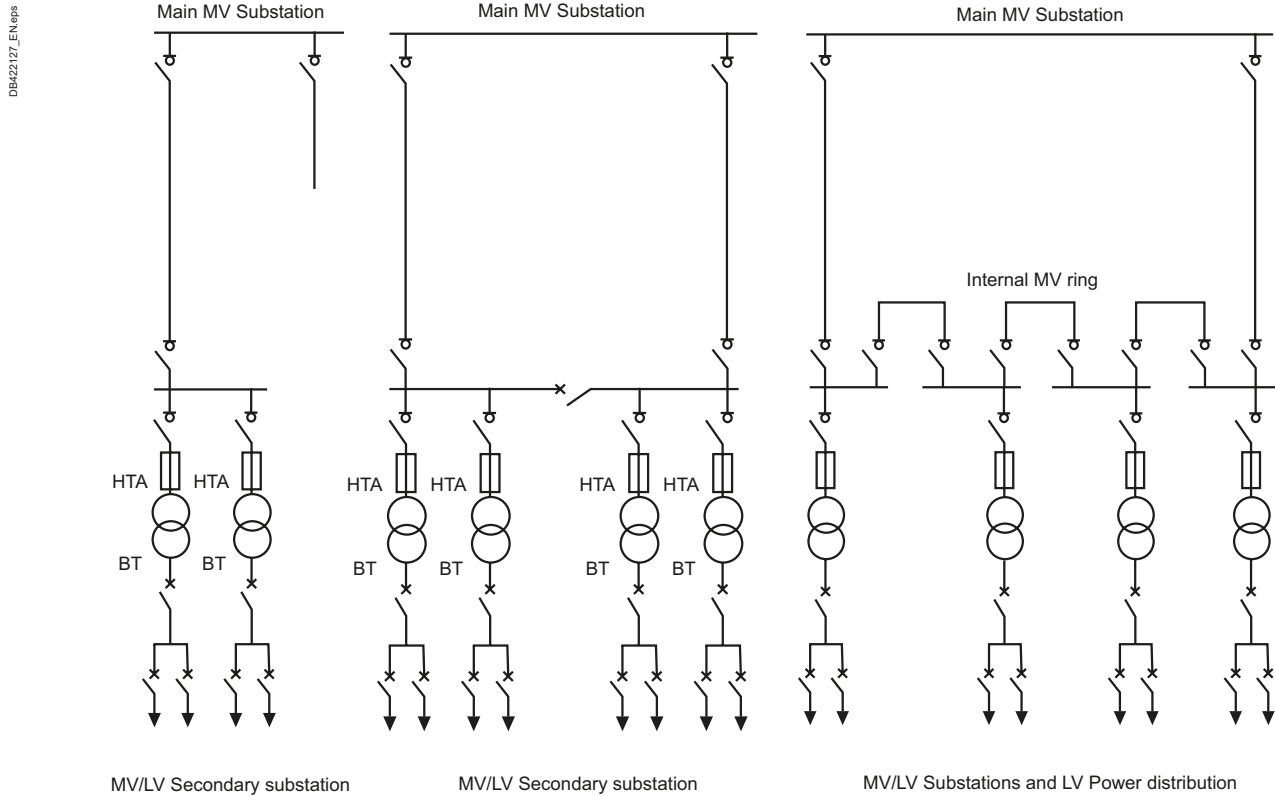


Fig. D11 Single feeder, Dual feeder, Open ring

Comparison of these three typical principles of internal distribution is given Fig. D12.

Characteristic to consider	MV circuit configuration		
	Single feeder	Open ring	Dual feeder
Site topology	Any	Single or several buildings	Single or several buildings
Power demand	Any	> 1250kVA	> 2500kVA
Disturbance sensitivity	Long interruption acceptable	Short interruption acceptable	Short interruption not acceptable

Fig. D12 Comparison of the typical internal circuits

6.3 Number and localisation of MV/LV transformer substations

The main criteria to consider for determination of the number and the location of the MV/LV substations are the following:

- Number of buildings
- Surface of each building
- Number of floors per building
- Repartition and power of the consumers
- Power demand per area, floor, building
- Sensitivity to interruption, need for redundancy

To determine the number and the location of the MV/LV substations, we may however give the following basic indications:

- Small and medium size building: One single MV/LV substation
- Large building: One or several MV/LV substations depending on the power and the repartition of the consumers
- Building with several floors: One or several MV/LV substations depending on the power and the repartition of the consumers. One MV/LV substation may be dedicated to each floor
- Large site with several buildings: One MV/LV substation may be dedicated to each building.

6.4 Number of MV/LV transformers

For every MV/LV substation, the definition of the number of MV/LV transformers takes into account the following criteria:

- Total power supplied by the substation
- Standardization of the rated power to reduce the number of spare transformers
- Limit of the rated power. It is recommended to set this limit at 1250 kVA in order to facilitate the handling and the replacement of the transformers
- Scalability of the installation
- Need to separate the loads having a high level of sensitivity to the electrical perturbations
- Need to dedicate a transformer to the load generating a high level of perturbation such as voltage dips, harmonics, flicker
- Need for partial or total redundancy. When required, two transformers each sized for the full load and equipped with an automatic change-over are installed
- Loads requiring a dedicated neutral system. IT for example to ensure the continuity of operation in case of phase to earth fault

6.5 MV back-up generator

MV back-up generators are required when in case of the utility failure it is necessary to ensure the supply of the totality of the loads or the major part of them.

For all the other situations LV back generators may be enough

The main criteria to consider for the implementation of MV back-up generators are the following:

- Site activity
- Sensitivity of the loads to power interruptions
- Level of availability of the public distribution network
- Process including a co-generation system
- Need to optimize the energy bill.

7 Choice of architecture details

This is the second stage in designing of electrical distribution design. During this stage we carry out the following choices:

- Layout,
- Centralized or decentralized distribution,
- Presence of back-up generators,
- Presence of uninterruptible power supplies,
- Configuration of LV distribution,
- Architecture combinations.

7.1 Layout

Position of the main MV and LV equipment on the site or in the building.
This layout choice is applied to the results of stage 1.

Selection guide:

As recommended in IEC60364-8-1 §6.3, MV/LV substation location can be determined by using the barycenter method:

- taking into account service conditions: in dedicated premises if the layout in the workshop is too restrictive (temperature, vibrations, dust, etc.)
- Placing heavy equipment (transformers, generators, etc.) close to walls or to main exits for ease of maintenance.

A layout example is given in the following diagram (Fig. D13):

DB422128_EN.eps

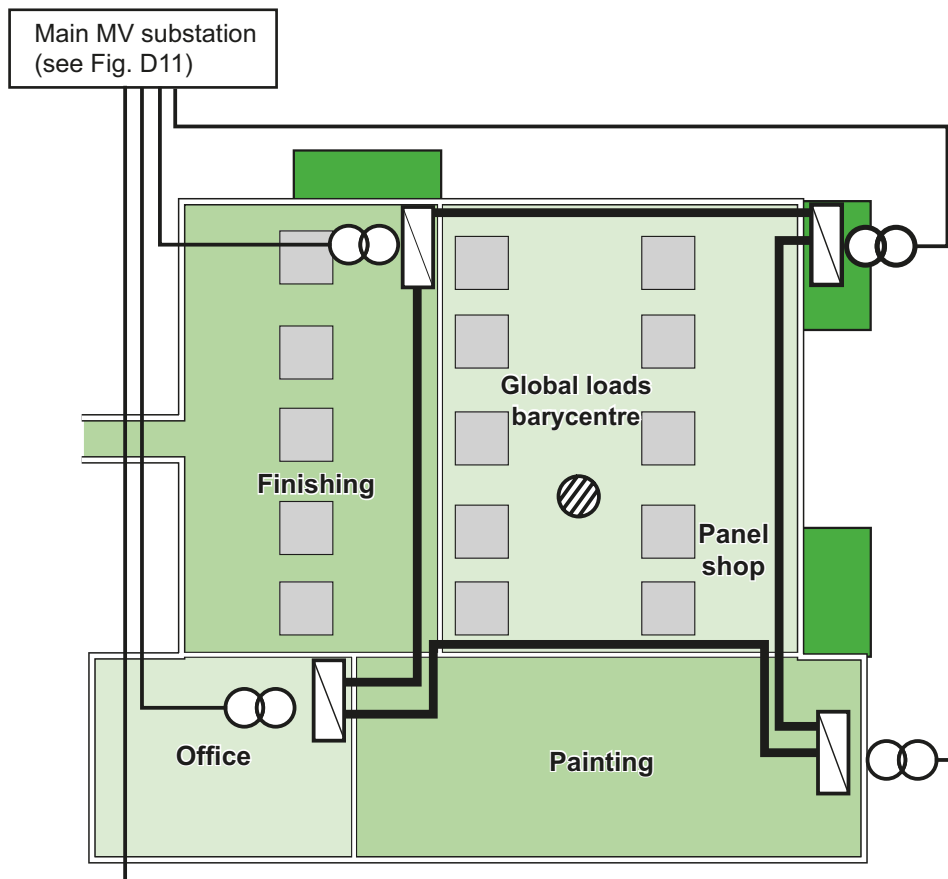


Fig. D13 The position of the global load barycentre guides the positioning of power sources

7 Choice of architecture details

7.2 Centralized or distributed layout of LV distribution

In **centralized layout**, each load is connected directly to the power source. (Fig. D14):

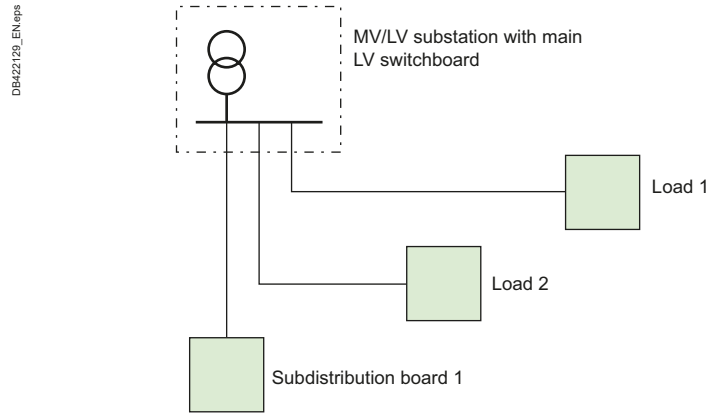


Fig. D14 Example of centralized layout with point to point links

In **distributed layout**, loads are connected to sources via a busway. This type of distribution is well adapted to supply many loads that are spread out, where easy change is requested or future new connection (need of flexibility) (Fig. D15):

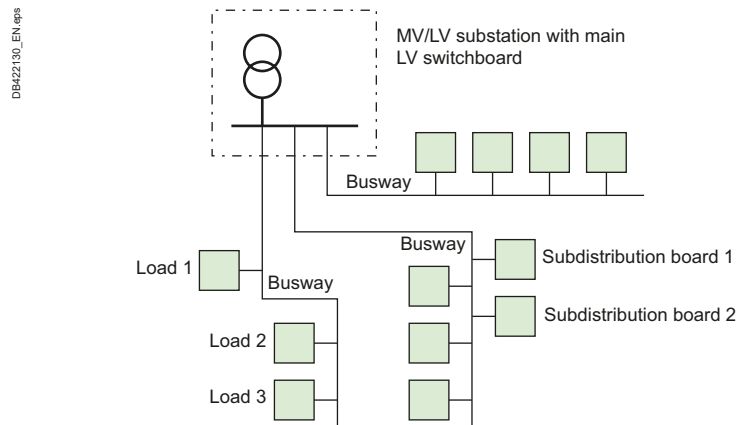


Fig. D15 Example of distributed layout, with busway

Factors in favour of centralized layout (see summary table in Fig. D16):

- Installation flexibility: no,
- Load distribution: localized loads (high unit power loads).

Factors in favor of distributed layout:

- Installation flexibility: "Implementation" flexibility (moving of workstations, etc...),
- Load distribution: uniform distribution of low or medium unit power loads

7 Choice of architecture details

Flexibility (see § 3.6 for definition of the flexibility levels)	Load distribution		
	Localized loads	Intermediate distribution loads	Uniformly distributed loads
No flexibility	Centralized		Decentralized
Flexibility of design			
Implementation flexibility	Centralized	Decentralized	
Operation flexibility			

Fig. D16 Recommendations for centralized or distributed layout

Centralized distribution gives greater independence of circuits, reducing the consequences of a failure from power availability point of view.

The use of decentralized distribution with busway is a way to merge all the circuits in one: it makes it possible to take into account the diversity factor (k_s), which means cost savings on conductor sizing (See fig. D17). The choice between centralized and decentralized solutions, according to the diversity factor, allows to find an economic optimum between investment costs, installation costs and operating costs.

These two distribution modes are often combined.

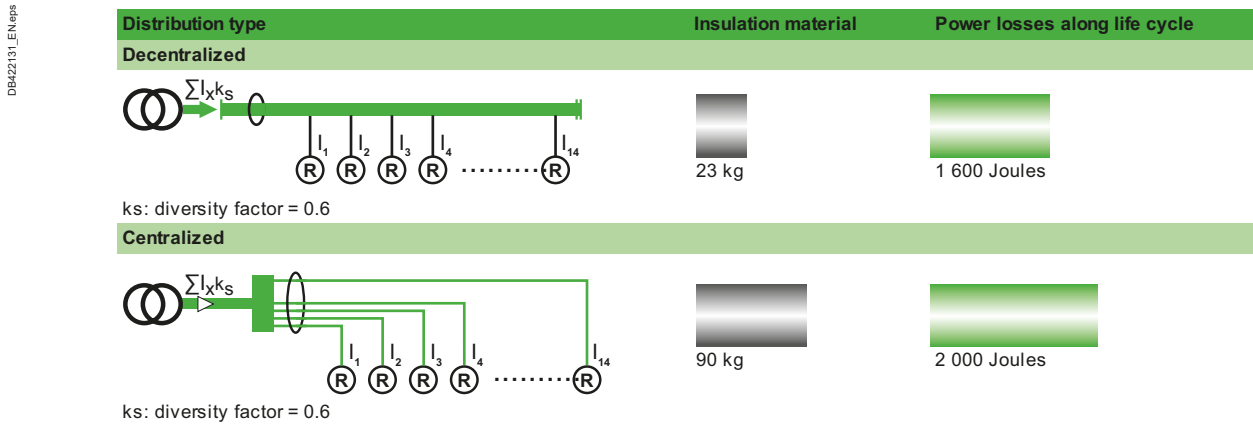


Fig. D17 Example of a set of 14 x 25A loads distributed along 34 meters (for busway, Canalis KS 250A)

DB422131_LENeips

7 Choice of architecture details

7.3 Presence of LV back-up generators

(see Fig. D18)

LV backup-up generator is the association of an alternator mechanically powered by a thermal engine.

No electrical power can be delivered until the generator has reached its rated speed. This type of device is therefore not suitable for an uninterrupted power supply.

Depending, if the generator is sized to supply power to all or only part of the installation, there is either total or partial redundancy.

A back-up generator runs generally disconnected from the network. A source changeover and an interlocking system is therefore required (see Fig. D18). The generator back-up time depends on the quantity of available fuel.

D20

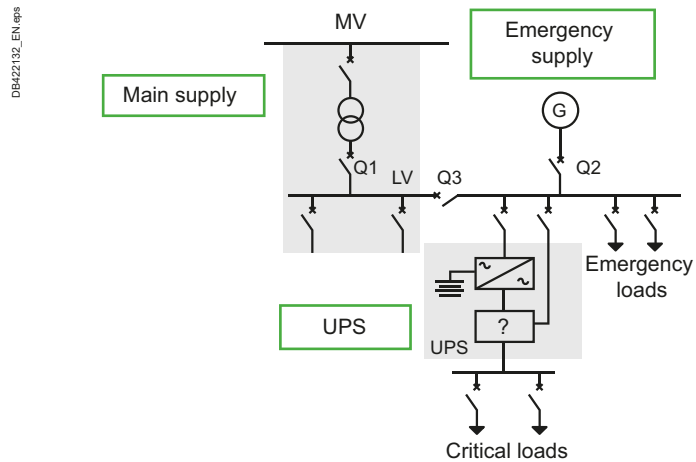


Fig. D18 Connection of a back-up generator

The main characteristics to consider for implementing LV back-up generator:

- Sensitivity of loads to power interruption (see § 3.9 for definition),
- Availability of the public distribution network (see § 3.4 for the definition),
- Other constraints (e.g.: generators compulsory in hospitals or high buildings)

In addition the presence of generators can be decided to reduce the energy bill or due to the opportunity for co-generation. These two aspects are not taken into account in this guide.

The presence of a back-up generator is essential if the loads cannot be shed (only short interruption acceptable) or if the utility network availability is low.

Determining the number of back-up generator units is in line with the same criteria as determining the number of transformers, as well as taking into account the economic and availability considerations (redundancy, start-up reliability, maintenance facility).

Determining the generator apparent power, depends on:

- installation power demand of loads to be supplied,
- transient constraints that can occur by motors inrush current for example

7 Choice of architecture details

7.4 Presence of an Uninterruptible Power Supply (UPS)

The electrical power from a UPS is supplied from a storage unit: batteries or inertia wheel. This system prevent any power failure. The back-up time of the system is limited: from several minutes to several hours.

The simultaneous presence of a back-up generator and a UPS unit is used for permanently supply loads for which no failure is acceptable (Fig. D19). The back-up time of the battery must be compatible with the maximum time for the generator to start up and take over the load supply.

A UPS unit is also used to supply loads that are sensitive to power quality (generating a “clean” voltage that is independent of the network).

Main characteristics to be considered for implementing a UPS:

- Sensitivity of loads to power interruptions (see § 3.9 for definition),
- Sensitivity of loads to disturbances (see § 3.10 for definition).

The presence of a UPS unit is essential if and only if no failure is acceptable.

DB42104_EN.eps

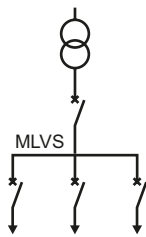


Fig. D20 Single feeder configuration

DB42105_EN.eps

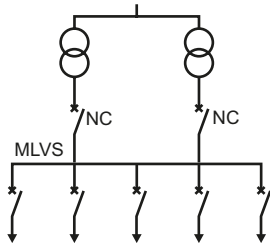


Fig. D21 Parallel transformers configuration

DB42106_EN.eps

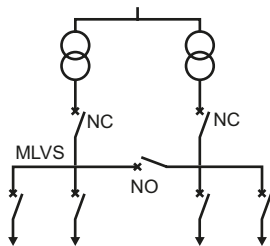


Fig. D22 Normally open coupled transformers

DB42108_EN.eps

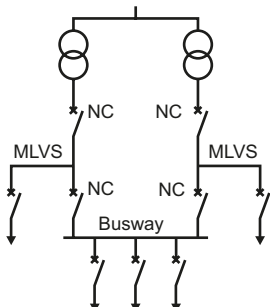


Fig. D23 Main LV switchboard interconnected by a busway

DB42103_EN.eps

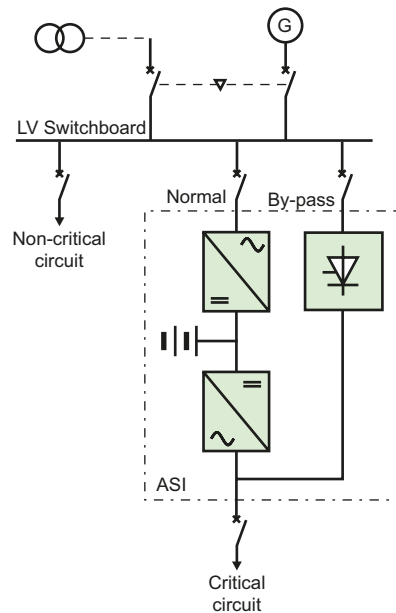


Fig. D19 Example of connection for a UPS

7.5 Configuration of LV circuits

Main possible configurations:

■ **Single feeder configuration (Fig. D20):** This is the reference configuration and the most simple. A load is connected to one single source. This configuration provides a minimum level of availability, since there is no redundancy in case of power source failure.

■ **Parallel transformers configuration (Fig. D21):** The power supply is provided by more than 1 transformer generally connected in parallel to the same main LV switchboard.

■ **Variant: Normally open coupled transformers (Fig. D22):** In order to increase the availability it is possible to split the main LV switchboard into 2 parts, with a normally open bus-coupler (NO). This configuration may require an Automatic Transfer Switch between the coupler and transformer incomers.

These 2 configurations are more often used when power demand is greater than 1 MVA.

■ **Main LV switchboard interconnected by a busway (Fig. D23):** Transformers are physically distant, and operated in parallel. They are connected by a busway, the load can always be supplied in the case of failure of one of the sources. The redundancy can be:

- Total: each transformer being able to supply all of the installation,
- Partial: each transformer only being able to supply part of the installation. In this case, part of the loads must be disconnected (load-shedding) in the case of one of transformer failure.

7 Choice of architecture details

D22

DB422139_EN.eps

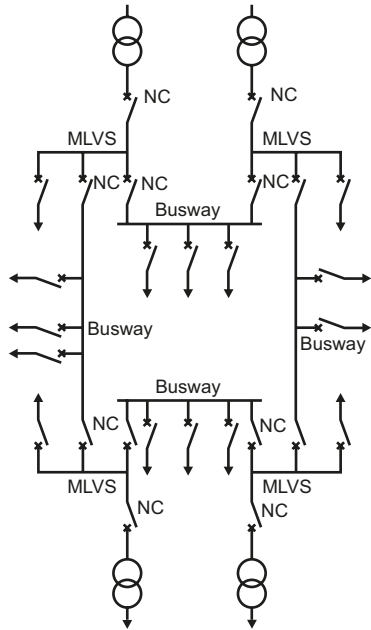


Fig. D24 Ring configuration

■ **LV ring configuration (Fig. D24):** This configuration can be considered as an extension of the previous configuration with interconnection between switchboards. Typically, 4 transformers connected in parallel to the same MV line, supply a ring using busway. A given load is then supplied by several transformers. This configuration is well suited to large sites, with high load density (in kVA/m²). If all of the loads can be supplied by 3 transformers, there is total redundancy in the case of failure of one of the transformers. In fact, each busbar can be fed by one or other of its ends. Otherwise, downgraded operation must be considered (with partial load shedding). This configuration requires special design of the protection plan in order to ensure selectivity in all of the fault circumstances.

As the previous configuration this type of installation is commonly used in automotive industry or large site manufacturing industry.

■ **Double-ended power supply (Fig. D25):** This configuration is implemented in cases where maximum availability is required. The principle involves having 2 independent power sources, e.g.:

- 2 transformers supplied by different MV lines,
- 1 transformer and 1 generator,
- 1 transformer and 1 UPS.

An automatic transfer switch (ATS) is used to avoid the sources being parallel connected. This configuration allows preventive and curative maintenance to be carried out on all of the electrical distribution system upstream without interrupting the power supply.

■ **Configuration combinations (Fig. D26):** An installation can be made up of several sub-assemblies with different configurations, according to requirements for the availability of the different types of load. E.g.: generator unit and UPS, choice by sectors (some sectors supplied by cables and others by busways).

DB422140_EN.eps

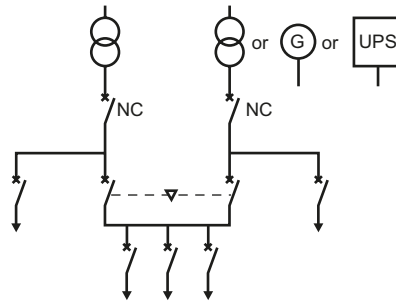


Fig. D25 Double-ended configuration with automatic transfer switch

DB422141_EN.eps

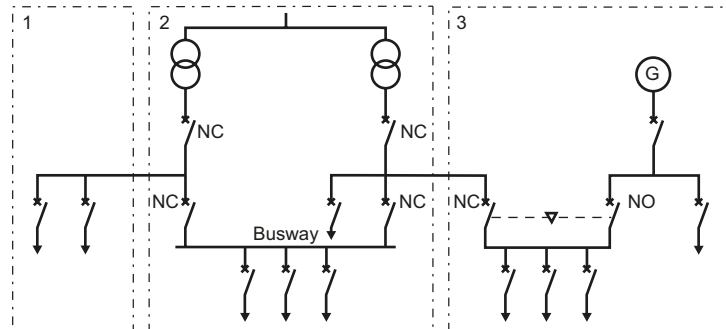


Fig. D26 Example of a configuration combination

1: Single feeder, 2: Main LV switchboard interconnected by a busway, 3: Double-ended

7 Choice of architecture details

For the different possible configurations, the most probable and usual set of characteristics is given in the following table:

Characteristic to be considered	Configuration				
	Single feeder (fig. D20)	Parallel transformer or transformers connected via a coupler (fig. D21-D22)	Main LV switchboard interconnected by a busway (fig D24)	LV ring	Double-ended
Site topology	Any	Any	1 level 5000 to 25000 m ²	1 level 5000 to 25000 m ²	Any
Power demand	< 2500kVA	Any	≥ 2500kVA	> 2500kVA	Any
Location latitude	Any	Any	Medium or high	Medium or high	Any
Load distribution	Localized loads	Localized loads	Intermediate or uniform load distribution	Intermediate or uniform load distribution	Localized loads
Maintainability	Minimal	Standard	Standard	Standard	Enhanced
Disturbances sensitivity	Low sensitivity	High sensitivity	High sensitivity	High sensitivity	High sensitivity

Fig. D27 Recommendations for the configuration of LV circuits

8 Choice of equipment

The choice of equipment is step 3 in the design of an electrical installation. The aim of this step is to select equipment from the manufacturers' catalogues. The choice of technological solutions results from the choice of architecture.

List of equipment to consider:

- MV/LV substation,
- MV switchboards,
- Transformers,
- LV switchboards,
- Busway,
- UPS units,
- Power factor correction and filtering equipment.
- Generators

Criteria to consider:

- Service conditions (presence of water, dust, etc.),
- Power availability, including service index for LV switchboards,
- Safety (for people using or operating the installation),
- Local regulations,
- Footprint,
- Offer availability per country,
- Utilities requirements,
- Previous architecture choices.

The choice of equipment is basically linked to the offer availability in the country. This criterion takes into account the availability of certain ranges of equipment or local technical support.

The detailed selection of equipment is out of the scope of this document.

9 Recommendations for architecture optimization

These recommendations are intended to guide the designer towards architecture upgrades which allow him to improve assessment criteria.

9.1 On-site work

To be compatible with the “special” or “critical” work-site time, it is recommended to limit uncertainties by applying the following recommendations:

- Use of proven solutions and equipment that has been validated and tested by manufacturers (“functional” switchboard or “manufacturer” switchboard according to the application criticality),
- Prefer the implementation of equipment for which there is a reliable distribution network and for which it is possible to have local support (supplier well established),
- Prefer the use of factory-built equipment (MV/LV substation, busway), allowing the volume of operations on site to be limited,
- Limit the variety of equipment implemented for example, when possible harmonize transformers power,
- Avoid mixing equipment from different manufacturers.

D25

9.2 Environmental impact

The optimization of the environmental impact of an installation will involve reducing:

- Power losses at loaded and also no-load conditions during all the period of operation of the installation,
- Overall, the mass of materials used to build the installation.

Taken separately and when looking at only one piece of equipment, these 2 objectives may seem contradictory. However, when applied to whole installation, it is possible to design the architecture to contribute to both objectives. The optimal installation will therefore not be the sum of the optimal equipment taken separately, but the result of an optimization of the overall installation.

Fig. D28 gives an example of the contribution per equipment category to the weight and energy dissipation for a 3500 kVA of installed power spread over an area of 10000m².

- Installation is operating at 50% load on average, with 0,8 power factor
- Site is operating 6500 hours per years : 3 shifts + week ends with reduced activity at night and week ends and full stop 1 month per year for site maintenance.
- Energy consumption is 9,1 GWh per year.

DB422142_EN.eps

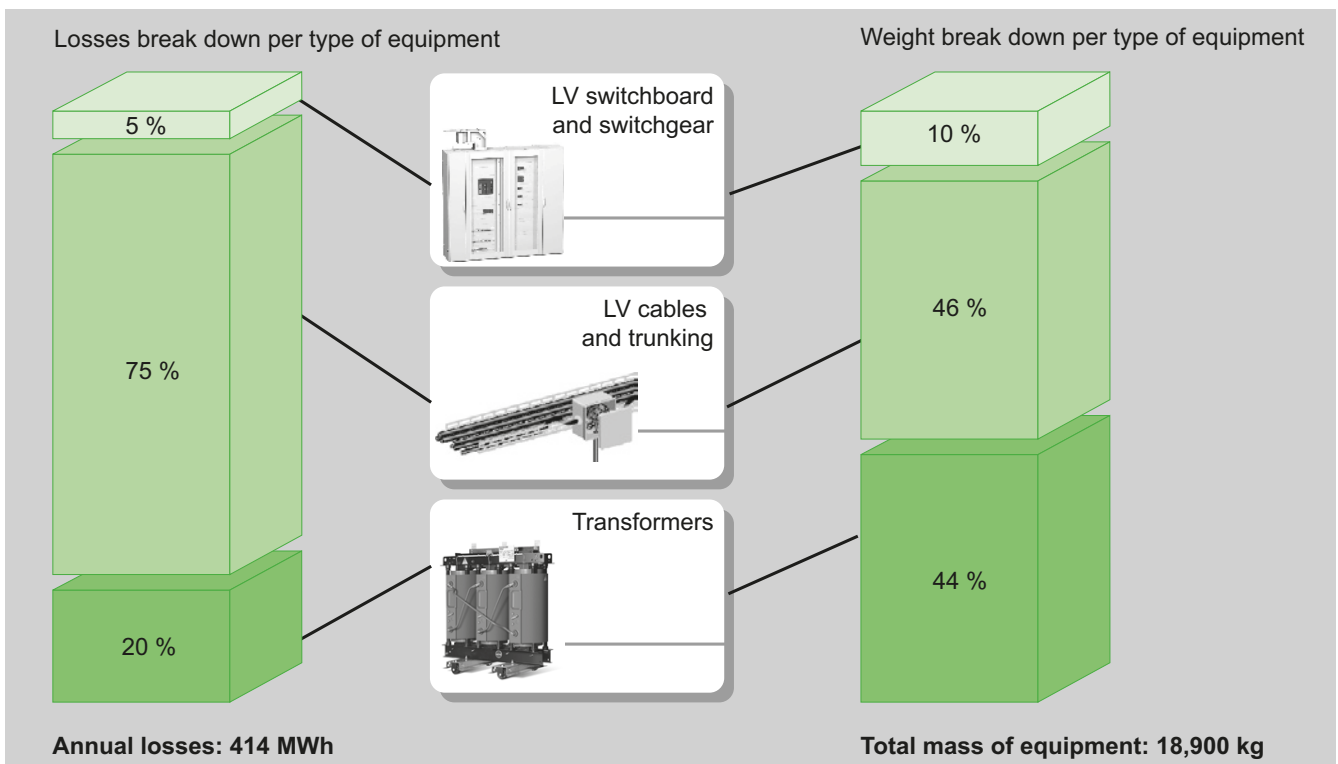


Fig. D28 Example of the break down of losses and the weight for each type of equipment

9 Recommendations for architecture optimization

D26

These data helps to understand and prioritize energy consumption and costs factors.

- Very first factor of power consumption is... energy usage. This can be optimized with appropriate metering and analysis of loads actual consumption.
- Second is reactive energy. This lead to additional load on upstream electrical network. and additional energy invoicing. This can be optimized with power factor correction solutions.
- Third is wiring system which represent 75% of the installation losses. Cable losses can be reduced by appropriate organisation and design of site and use of busway wherever appropriate.
- MV/LV transformers are fourth with approx. 20% of the losses (1% of the site energy consumption).
- MV and LV switchboards come last with approximately 5% of the losses (0,25% of the site energy consumption).

Generally speaking, LV cables and busway as well as the MV/LV transformers are the main contributors to losses and weight of equipment used.

Environmental optimization of the installation by the architecture design will therefore involve:

- reducing the length of LV circuits in the installation, as proposed by the barycentre method in IEC60364-8-1 §6.3, and § 7.1 of this chapter
- clustering LV circuits wherever possible to take advantage of the diversity ks (see chapter A: General rules of electrical installation design, Subclause 4.3 "Estimation of actual maximum kVA demand")

Objectives	Resources
Reducing the length of LV circuits	Placing MV/LV substations as close as possible to the barycenter of all of the LV loads to be supplied
Clustering LV circuits	<p>When the diversity factor of a group of loads to be supplied is less than 0.7, the clustering of circuits allows us to limit the volume of conductors supplying power to these loads.</p> <p>In real terms this involves:</p> <ul style="list-style-type: none"> ■ setting up sub-distribution switchboards as close as possible to the barycenter of the groups of loads if they are localized, ■ setting up busbar trunking systems as close as possible to the barycenter of the groups of loads if they are distributed. <p>The search for an optimal solution may lead to consider several clustering scenarios.</p> <p>In all cases, reducing the distance between the barycenter of a group of loads and the equipment that supplies them power allows to reduce environmental impact.</p>

Fig. D29 Environmental optimization: Objectives and Resources

9 Recommendations for architecture optimization

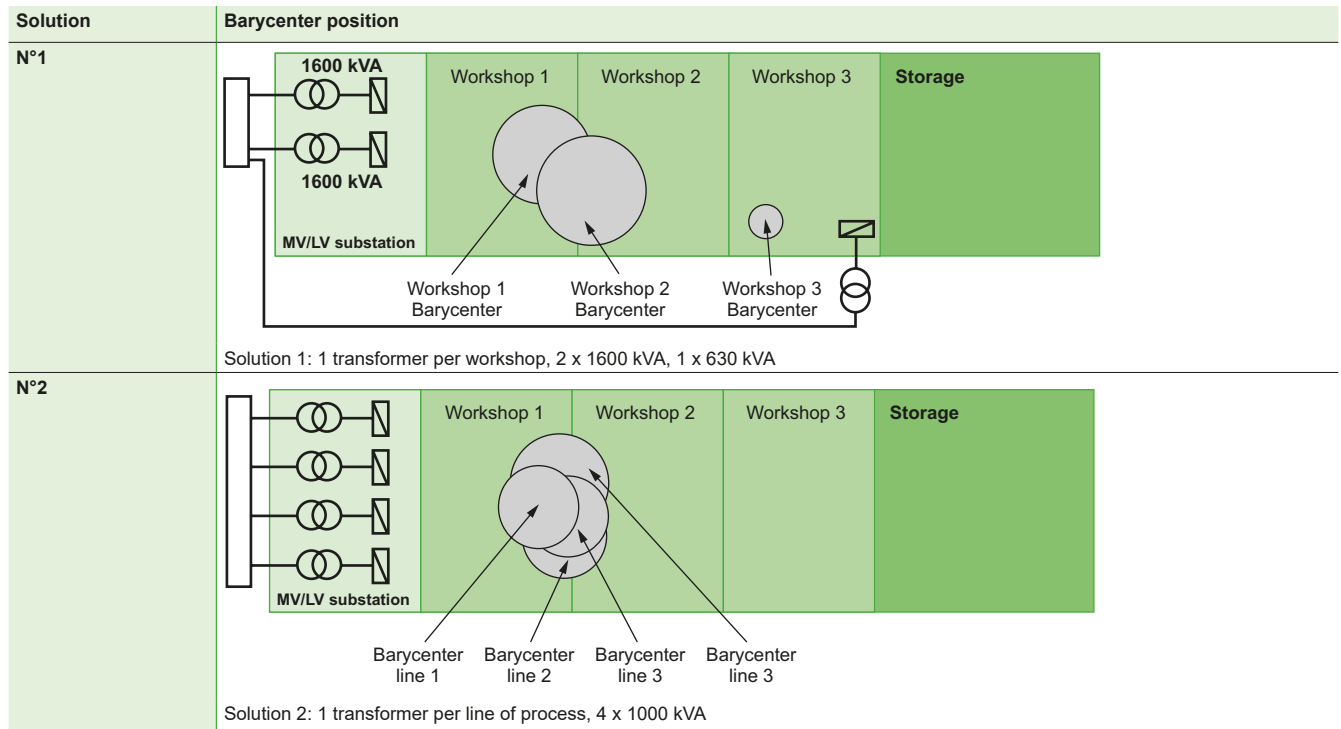


Fig. D30 Example of barycentres positioning according to load clustering

As an example Fig. D30 shows the impact of clustering circuits on different ways and the impact on the barycentres of the clustered loads. This example concerns a mineral water bottling plant for which:

- the installed power is around 4 MVA.

In solution No.1, the circuits are clustered by workshop.

In solution No. 2, the circuits are clustered by process functions (production lines).

In this example 2 different solutions can be used at the MV/LV level:

- solution 1, a MV/LV transformer is moved close to workshop 3 to optimize its place according to the barycentre of the loads (its more economic to transmit the power in MV when possible)
- solution 2, all MV/LV transformers are in the same substation, and with the same size, allowing also a partial operation of the plant (1/2 of the plant).

In addition, in the 2 solutions the optimization can also be carried out by the following points:

- the setting up of LV power factor correction to limit losses in the transformers and LV circuits if this compensation is distributed,
- the use of low losses transformers,
- the use of aluminum busway when possible, since natural resources of this metal are greater.

9 Recommendations for architecture optimization

9.3 Preventive maintenance volume

Recommendations for reducing the volume of preventive maintenance:

- Use the same recommendations as for reducing the work site time,
- Focus maintenance work on critical circuits,
- Standardize the choice of equipment,
- Use equipment designed for severe atmospheres (requires less maintenance).

9.4 Electrical power availability

Recommendations for improving the electrical power availability:

- Reduce the number of feeders per switchboard, in order to limit the effects of a possible failure of a switchboard,
- Distributing circuits according to availability requirements,
- Using equipment that is in line with requirements (see Service Index, 4.2),
- Follow the selection guides proposed for steps 1 & 2 (see [Fig. D3](#)).

Recommendations to increase the level of availability:

- Change from a radial single feeder configuration to a parallel transformers configuration,
- Change from a parallel transformers configuration to a double-ended configuration,
- Add to a double-ended configuration a UPS unit and a Static Transfer Switch
- Increase the level of maintenance (reducing the MTTR, increasing the MTBF)

10 Glossary

Architecture: choice of a single-line diagram and technological solutions, from connection to the utility network through load power supply circuits.

Main MV/LV distribution: Level upstream of the architecture, from connection to the network utility through to LV distribution equipment on the site (MLVS – or equivalent).

MLVS – Main Low Voltage Switchboard: Main switchboard downstream of the MV/LV transformer, starting point of power distribution circuits in the installation

LV power distribution: intermediate level in the architecture, downstream of the main level through to the sub-distribution switchboards (spatial and functional distribution of electrical power in the circuits).

LV terminal distribution: Downstream level of the architecture, downstream of the sub-distribution switchboards through to the loads. This level of distribution is not dealt with in this guide.

Single-line diagram: general electrical schematic diagram to represent the main electrical equipment and their interconnection.

MV substation, transformation substation: Enclosures grouping together MV equipment and/or MV/LV transformers. These enclosures can be shared or separate, according to the site layout, or the equipment technology. In certain countries, the MV substation is assimilated with the delivery substation.

Technological solution: Resulting from the choice of technology for an installation sub-assembly, from among the different products and equipment proposed by the manufacturer.

Characteristics: Technical or environmental data relative to the installation, enabling the best-suited architecture to be selected.

Criteria: Parameters for assessing the installation, enabling selection of the architecture that is the best-suited to the needs of the customer.

11 Example: electrical installation in a printworks

11.1 Brief description

Printing of personalized mailshots intended for mail order sales.

11.2 Installation characteristics

Characteristic	Category
Activity	Mechanical
Site topology	single storey building, 10000m ² (8000m ² dedicated to the process, 2000m ² for ancillary areas)
Layout latitude	High
Service reliability	Standard
Maintainability	Standard
Installation flexibility	<ul style="list-style-type: none"> ■ No flexibility planned: <ul style="list-style-type: none"> <input type="checkbox"/> HVAC <input type="checkbox"/> Process utilities <input type="checkbox"/> Office power supply ■ Possible flexibility: <ul style="list-style-type: none"> <input type="checkbox"/> finishing, putting in envelopes <input type="checkbox"/> special machines, installed at a later date <input type="checkbox"/> rotary machines (uncertainty at the draft design stage)
Power demand	3500kVA
Load distribution	Intermediate distribution
Power interruptions sensitivity	<ul style="list-style-type: none"> ■ Sheddable circuits: <ul style="list-style-type: none"> <input type="checkbox"/> offices (apart from PC power sockets) <input type="checkbox"/> air conditioning, office heating <input type="checkbox"/> social premises <input type="checkbox"/> maintenance premises ■ long interruptions acceptable: <ul style="list-style-type: none"> <input type="checkbox"/> printing machines <input type="checkbox"/> workshop HVAC (hygrometric control) <input type="checkbox"/> Finishing, envelope filling <input type="checkbox"/> Process utilities (compressor, recycling of cooled water) ■ No interruptions acceptable: <ul style="list-style-type: none"> <input type="checkbox"/> servers, office PCs
Disturbance sensitivity	<ul style="list-style-type: none"> ■ Average sensitivity: <ul style="list-style-type: none"> <input type="checkbox"/> motors, lighting ■ High sensitivity: <ul style="list-style-type: none"> <input type="checkbox"/> IT <p>No special precaution to be taken due to the connection to the EdF network (low level of disturbance)</p>
Disturbance capability	Non disturbing
Other constraints	<ul style="list-style-type: none"> ■ Building with lightning classification: lightning surge arresters installed ■ Power supply by overhead single feeder line

11.3 Technological characteristics

Criteria	Category
Service conditions	<ul style="list-style-type: none"> ■ IP: standard (no dust, no water protection) ■ IK: standard (use of technical pits, dedicated premises) ■ °C: standard (temperature regulation)
Required service index	211
Offer availability by country	No problem (project carried out in Europe)
Other criteria	Not applicable

D30

11 Example: electrical installation in a printworks

11.4 Architecture assessment criteria

Criteria	Category
On-site work time	Standard (see 5.1)
Environmental impact	Minimal: compliance with European standard regulations
Preventive maintenance costs	Standard (see 5.3)
Power supply availability	Tier 1 (see 5.4)

Step 1: Architecture fundamentals

Choice	Main criteria	Solution
Connection to upstream network	Isolated site, 3500 kVA	MV single-line service
MV Circuits	Layout + criticality	single feeder
Number of transformers	Power > 2500kVA	2 x 2000kVA
Number and distribution of substations	Surface area and power distribution	2 possible solutions: 1 substation or 2 substations ■ if 1 substations: Normally open bus-coupler between MLVS ■ if 2 substations: Main LV switchboard interconnected by a busway
MV Generator	Site activity	No

D31

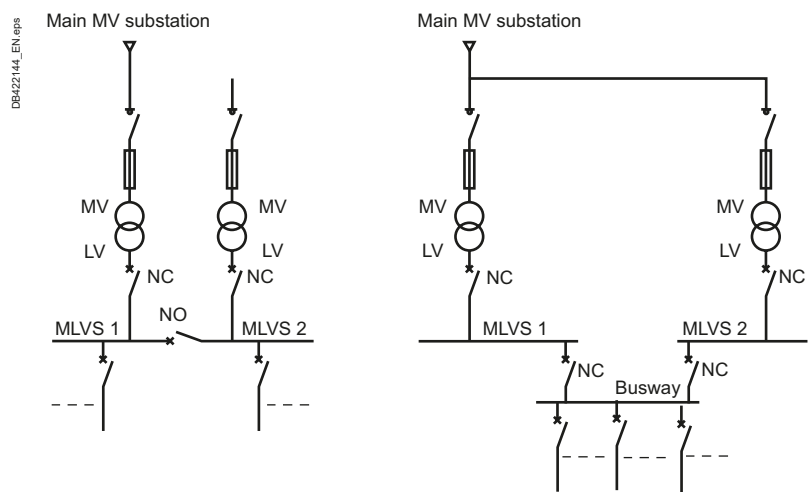


Fig. D31 Two possible single-line diagrams

11 Example: electrical installation in a printworks

D32

Step 2: Architecture details

Choice	Main criteria	Solution
Layout	Service conditions	Dedicated premises
LV circuit configuration	2 transformers, requested by the power demand	Solution from fig.D22 or D23 are possible
Centralized or distributed layout	Uniform loads, distributed power, scalability possibilities Non-uniform loads, direct link from MLVS	<ul style="list-style-type: none"> ■ Decentralized with busbar trunking: <ul style="list-style-type: none"> □ finishing sector, envelope filling ■ Centralized with cables: <ul style="list-style-type: none"> □ special machines, rotary machines, HVAC, process utilities, offices (2 switchboards), office air conditioning, social premises, maintenance
Presence of back-up generator	Criticality ≤ low Network availability: standard	No back-up generator
Presence of UPS	Criticality	UPS unit for IT devices and office workstations

DB422146_EN.eps

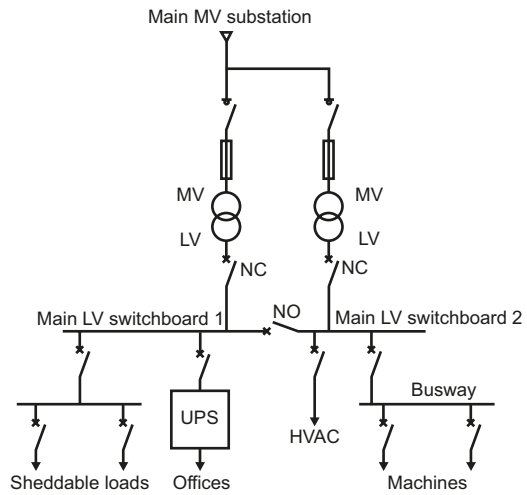


Fig. D32 Detailed single-line diagram (1 substation based on fig.D22)

DB422146_EN.eps

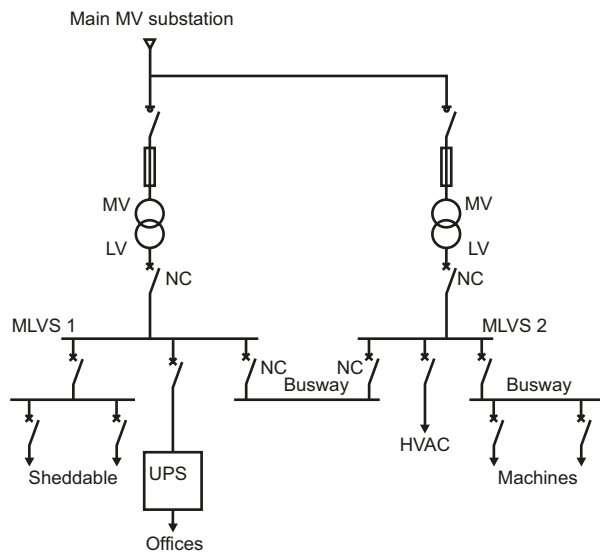


Fig. D33 Detailed single-line diagram (2 substation based on fig.D24)

11 Example: electrical installation in a printworks

11.5 Choice of technological solutions

Choice	Main criteria	Solution
MV/LV substation	Service conditions	indoor (dedicated premises)
MV switchboard	Offer availability by country	SM6 (installation in Europe)
Transformers	Service conditions	cast resin transfo (avoids constraints related to oil)
LV switchboard	Service conditions, service index for LV switchboards	MLVS: Prisma P Sub-distribution: Prisma
Busway	Load distribution	Canalis KS (fig.D32 or D33) Canalis KT for main distribution (fig D33)
UPS units	Installed power to be supplied, back-up time	Galaxy PW
Power factor correction	Reactive power to provide for the minimum up to the full load without harmonic (see chapter L for more information), presence of harmonics	LV automatic compensation (without detuned reactor).

D33

Chapter E

LV Distribution

1	Earthing schemes	E2
	1.1 Earthing connections	E2
	1.2 Definition of standardised earthing schemes	E3
	1.3 Characteristics of TT, TN and IT systems	E6
	1.4 Selection criteria for the TT, TN and IT systems	E8
	1.5 Choice of earthing method - implementation	E10
	1.6 Installation and measurements of earth electrodes	E11
2	The installation system	E15
	2.1 Distribution switchboards	E15
	2.2 Cables and busways	E25
	2.3 Harmonic currents in the selection of busbar trunking systems (busways)	E31
3	External influences (IEC 60364-5-51)	E37
	3.1 Definition and reference standards	E37
	3.2 Classification	E37
	3.3 List of external influences	E37
	3.4 Protection provided for enclosed equipment: codes IP and IK	E40

E1

1 Earthing schemes

In a building, the connection of all metal parts of the building and all exposed conductive parts of electrical equipment to an earth electrode prevents the appearance of dangerously high voltages between any two simultaneously accessible metal parts

E2

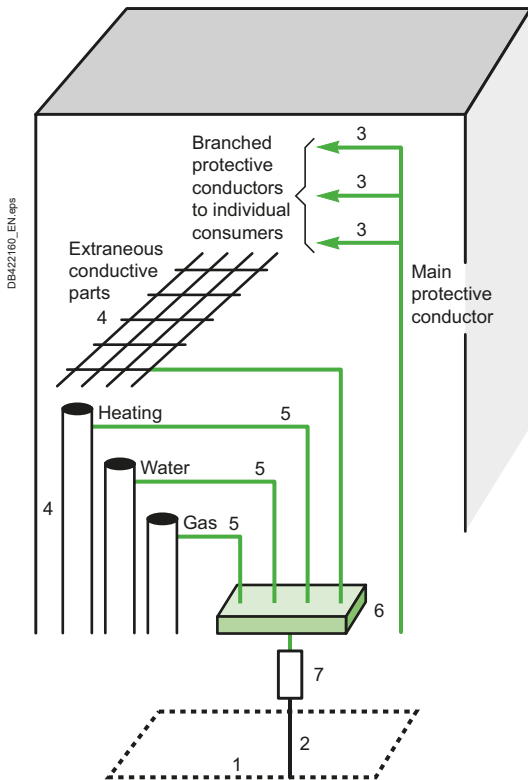


Fig. E1 An example of a block of flats in which the main earthing terminal (6) provides the main equipotential connection; the removable link (7) allows an earth-electrode-resistance check

1.1 Earthing connections

Definitions

National and international standards (IEC 60364) clearly define the various elements of earthing connections. The following terms are commonly used in industry and in the literature. Bracketed numbers refer to **Fig. E1**:

- Earth electrode (1): A conductor or group of conductors in intimate contact with, and providing an electrical connection with Earth (cf details in section 1.6 of **Chapter E**.)
- Earth: The conductive mass of the Earth, whose electric potential at any point is conventionally taken as zero
- Electrically independent earth electrodes: Earth electrodes located at such a distance from one another that the maximum current likely to flow through one of them does not significantly affect the potential of the other(s)
- Earth electrode resistance: The contact resistance of an earth electrode with the Earth
- Earthing conductor (2): A protective conductor connecting the main earthing terminal (6) of an installation to an earth electrode (1) or to other means of earthing (e.g. TN systems);
- Exposed-conductive-part: A conductive part of equipment which can be touched and which is not a live part, but which may become live under fault conditions
- Protective conductor (3): A conductor used for some measures of protection against electric shock and intended for connecting together any of the following parts:
 - Exposed-conductive-parts
 - Extraneous-conductive-parts
 - The main earthing terminal
 - Earth electrode(s)
 - The earthed point of the source or an artificial neutral
- Extraneous-conductive-part: A conductive part liable to introduce a potential, generally earth potential, and not forming part of the electrical installation (4).

For example:

- Non-insulated floors or walls, metal framework of buildings
- Metal conduits and pipework (not part of the electrical installation) for water, gas, heating, compressed-air, etc. and metal materials associated with them
- Bonding conductor (5): A protective conductor providing equipotential bonding
- Main earthing terminal (6): The terminal or bar provided for the connection of protective conductors, including equipotential bonding conductors, and conductors for functional earthing, if any, to the means of earthing.

Connections

The main equipotential bonding system

The bonding is carried out by protective conductors and the aim is to ensure that, in the event of an incoming extraneous conductor (such as a gas pipe, etc.) being raised to some potential due to a fault external to the building, no difference of potential can occur between extraneous-conductive-parts within the installation.

The bonding must be effected as close as possible to the point(s) of entry into the building, and be connected to the main earthing terminal (6).

However, connections to earth of metallic sheaths of communications cables require the authorisation of the owners of the cables.

Supplementary equipotential connections

These connections are intended to connect all exposed-conductive-parts and all extraneous-conductive-parts simultaneously accessible, when correct conditions for protection have not been met, i.e. the original bonding conductors present an unacceptably high resistance.

Connection of exposed-conductive-parts to the earth electrode(s)

The connection is made by protective conductors with the object of providing a low-resistance path for fault currents flowing to earth.

1 Earthing schemes

Components (see Fig. E2)

Effective connection of all accessible metal fixtures and all exposed-conductive-parts of electrical appliances and equipment, is essential for effective protection against electric shocks.

Component parts to consider:	
as exposed-conductive-parts	as extraneous-conductive-parts
Cableways ■ Conduits ■ Impregnated-paper-insulated lead-covered cable, armoured or unarmoured ■ Mineral insulated metal-sheathed cable (pyrotenax, etc.) Switchgear ■ cradle of withdrawable switchgear Appliances ■ Exposed metal parts of class 1 insulated appliances Non-electrical elements ■ metallic fittings associated with cableways (cable trays, cable ladders, etc.) ■ Metal objects: □ Close to aerial conductors or to busbars □ In contact with electrical equipment.	Elements used in building construction ■ Metal or reinforced concrete (RC): □ Steel-framed structure □ Reinforcement rods □ Prefabricated RC panels ■ Surface finishes: □ Floors and walls in reinforced concrete without further surface treatment □ Tiled surface ■ Metallic covering: □ Metallic wall covering Building services elements other than electrical ■ Metal pipes, conduits, trunking, etc. for gas, water and heating systems, etc. ■ Related metal components (furnaces, tanks, reservoirs, radiators) ■ Metallic fittings in wash rooms, bathrooms, toilets, etc. ■ Metallised papers
Component parts not to be considered:	
as exposed-conductive-parts	as extraneous-conductive-parts
Diverse service channels, ducts, etc. ■ Conduits made of insulating material ■ Mouldings in wood or other insulating material ■ Conductors and cables without metallic sheaths Switchgear ■ Enclosures made of insulating material Appliances All appliances having class II insulation regardless of the type of exterior envelope	■ Wooden-block floors ■ Rubber-covered or linoleum-covered floors ■ Dry plaster-block partition ■ Brick walls ■ Carpets and wall-to-wall carpeting

Fig. E2 List of exposed-conductive-parts and extraneous-conductive-parts

E3

The different earthing schemes (often referred to as the type of power system or system earthing arrangements) described characterise the method of earthing the installation downstream of the secondary winding of a MV/LV transformer and the means used for earthing the exposed conductive-parts of the LV installation supplied from it

1.2 Definition of standardised earthing schemes

The choice of these methods governs the measures necessary for protection against indirect-contact hazards.

The earthing system qualifies three originally independent choices made by the designer of an electrical distribution system or installation:

- The type of connection of the electrical system (that is generally of the neutral conductor) and of the exposed parts to earth electrode(s)
- A separate protective conductor or protective conductor and neutral conductor being a single conductor
- The use of earth fault protection of overcurrent protective switchgear which clear only relatively high fault currents or the use of additional relays able to detect and clear small insulation fault currents to earth.

In practice, these choices have been grouped and standardised as explained below.

Each of these choices provides standardised earthing systems with three advantages and drawbacks:

- Connection of the exposed conductive parts of the equipment and of the neutral conductor to the PE conductor results in equipotentiality and lower overvoltages but increases earth fault currents
- A separate protective conductor is costly even if it has a small cross-sectional area but it is much more unlikely to be polluted by voltage drops and harmonics, etc. than a neutral conductor is. Leakage currents are also avoided in extraneous conductive parts
- Installation of residual current protective relays or insulation monitoring devices are much more sensitive and permits in many circumstances to clear faults before heavy damage occurs (motors, fires, electrocution). The protection offered is in addition independent with respect to changes in an existing installation.

1 Earthing schemes

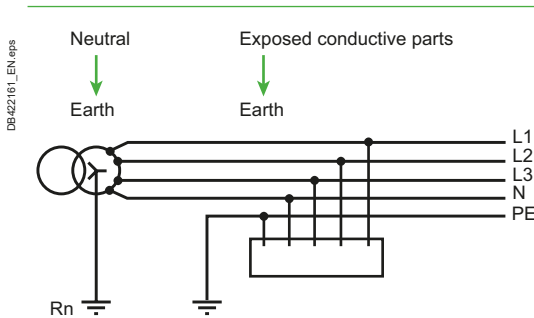


Fig. E3 TT System

TT system (earthed neutral) (see Fig. E3)

One point at the supply source is connected directly to earth. All exposed- and extraneous-conductive-parts are connected to a separate earth electrode at the installation. This electrode may or may not be electrically independent of the source electrode. The two zones of influence may overlap without affecting the operation of protective devices.

TN systems (exposed conductive parts connected to the neutral)

The source is earthed as for the TT system (above). In the installation, all exposed- and extraneous-conductive-parts are connected to the neutral conductor. The several versions of TN systems are shown below.

E4

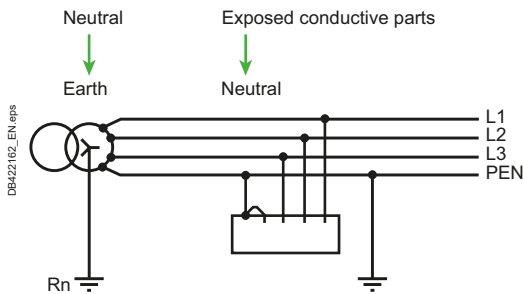


Fig. E4 TN-C system

TN-C system (see Fig. E4)

The neutral conductor is also used as a protective conductor and is referred to as a PEN (Protective Earth and Neutral) conductor. This system is not permitted for conductors of less than 10 mm² or for portable equipment.

The TN-C system requires an effective equipotential environment within the installation with dispersed earth electrodes spaced as regularly as possible since the PEN conductor is both the neutral conductor and at the same time carries phase unbalance currents as well as 3rd order harmonic currents (and their multiples).

The PEN conductor must therefore be connected to a number of earth electrodes in the installation.

Caution: In the TN-C system, the “protective conductor” function has priority over the “neutral function”. In particular, a PEN conductor must always be connected to the earthing terminal of a load and a jumper is used to connect this terminal to the neutral terminal.

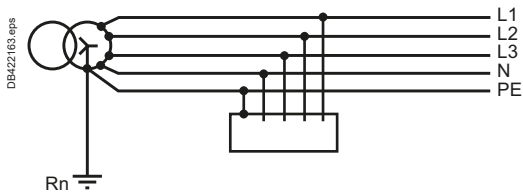


Fig. E5 TN-S system

TN-S system (see Fig. E5)

The TN-S system (5 wires) is obligatory for circuits with cross-sectional areas less than 10 mm² for portable equipment.

The protective conductor and the neutral conductor are separate. On underground cable systems where lead-sheathed cables exist, the protective conductor is generally the lead sheath. The use of separate PE and N conductors (5 wires) is obligatory for circuits with cross-sectional areas less than 10 mm² for portable equipment.

TN-C-S system (see Fig. E6 below and Fig. E7 next page)

The TN-C and TN-S systems can be used in the same installation. In the TN-C-S system, the TN-C (4 wires) system must never be used downstream of the TN-S (5 wires) system, since any accidental interruption in the neutral on the upstream part would lead to an interruption in the protective conductor in the downstream part and therefore a danger.

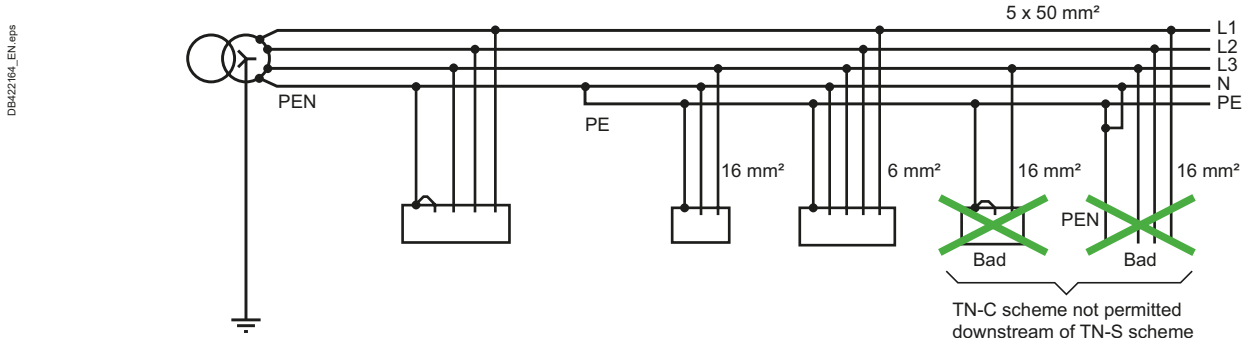


Fig. E6 TN-C-S system

1 Earthing schemes

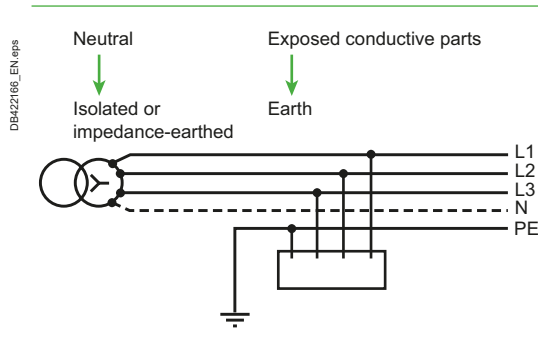


Fig. E8 IT system (isolated neutral)

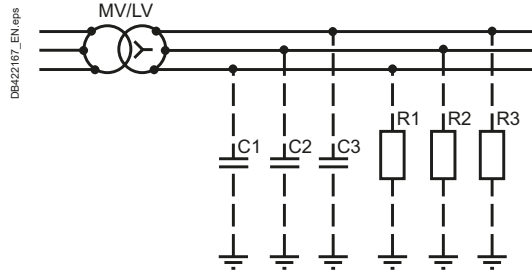


Fig. E9 Leakage impedance to earth in IT system

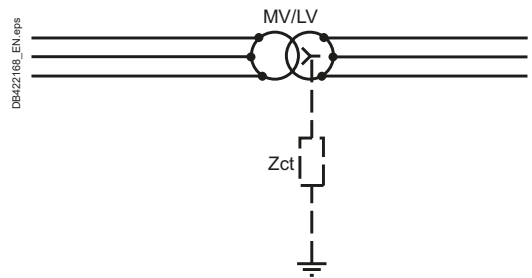


Fig. E10 Impedance equivalent to leakage impedances in an IT system

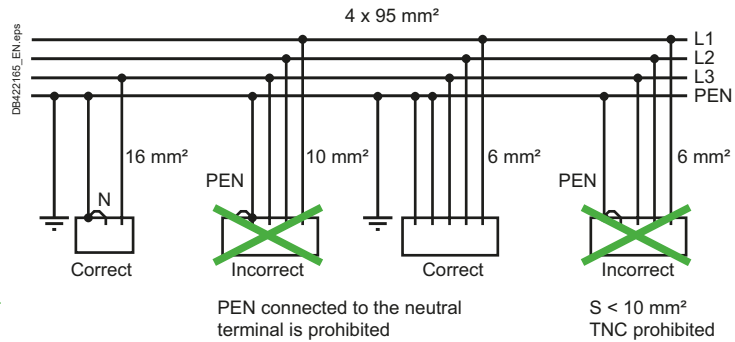


Fig. E7 Connection of the PEN conductor in the TN-C system

IT system (isolated or impedance-earthed neutral)

IT system (isolated neutral)

No intentional connection is made between the neutral point of the supply source and earth (see Fig. E8)

Exposed- and extraneous-conductive-parts of the installation are connected to an earth electrode.

In practice all circuits have a leakage impedance to earth, since no insulation is perfect. In parallel with this (distributed) resistive leakage path, there is the distributed capacitive current path, the two paths together constituting the normal leakage impedance to earth (see Fig. E9).

Example (see Fig. E10)

In a LV 3-phase 3-wire system, 1 km of cable will have a leakage impedance due to C1, C2, C3 and R1, R2 and R3 equivalent to a neutral earth impedance Z_{ct} of 3000 to 4000 Ω , without counting the filtering capacitances of electronic devices.

IT system (impedance-earthed neutral)

An impedance Z_s (in the order of 1000 to 2000 Ω) is connected permanently between the neutral point of the transformer LV winding and earth (see Fig. E11). All exposed- and extraneous-conductive-parts are connected to an earth electrode. The reasons for this form of power-source earthing are to fix the potential of a small network with respect to earth (Z_s is small compared to the leakage impedance) and to reduce the level of overvoltages, such as transmitted surges from the MV windings, static charges, etc. with respect to earth. It has, however, the effect of slightly increasing the first-fault current level.

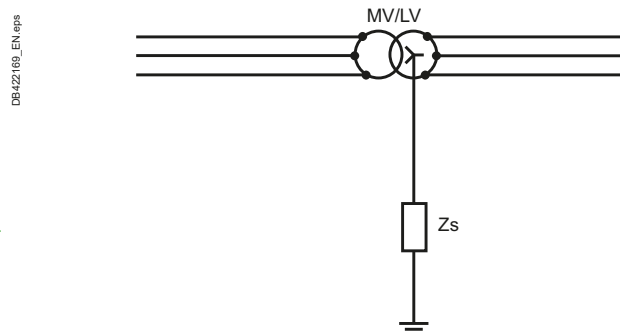


Fig. E11 IT system (impedance-earthed neutral)

1 Earthing schemes

The TT system:

- Technique for the protection of persons: the exposed conductive parts are earthed and residual current devices (RCDs) are used
- Operating technique: interruption for the first insulation fault

1.3 Characteristics of TT, TN and IT systems

TT system (see Fig. E12)

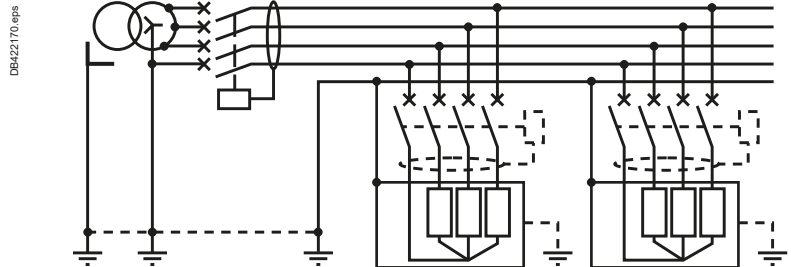


Fig. E12 TT system

Note: If the exposed conductive parts are earthed at a number of points, an RCD must be installed for each set of circuits connected to a given earth electrode.

Main characteristics

- Simplest solution to design and install. Used in installations supplied directly by the public LV distribution network.
- Does not require continuous monitoring during operation (a periodic check on the RCDs may be necessary).
- Protection is ensured by special devices, the residual current devices (RCD), which also prevent the risk of fire when they are set to ≤ 500 mA.
- Each insulation fault results in an interruption in the supply of power, however the outage is limited to the faulty circuit by installing the RCDs in series (selective RCDs) or in parallel (circuit selection).
- Loads or parts of the installation which, during normal operation, cause high leakage currents, require special measures to avoid nuisance tripping, i.e. supply the loads with a separation transformer or use specific RCDs (see section 5.1 in chapter F).

The TN system:

- Technique for the protection of persons:
 - Interconnection and earthing of exposed conductive parts and the neutral are mandatory
 - Interruption for the first fault using overcurrent protection (circuit breakers or fuses)
- Operating technique: interruption for the first insulation fault

TN system (see Fig. E13 and Fig. E14)

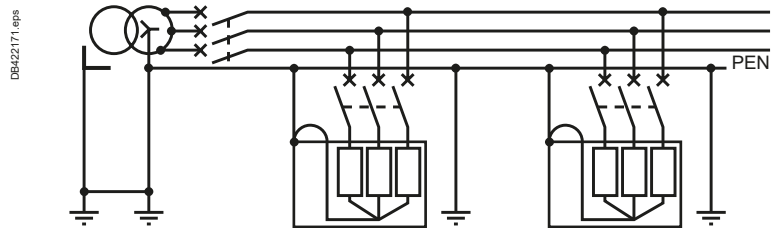


Fig. E13 TN-C system

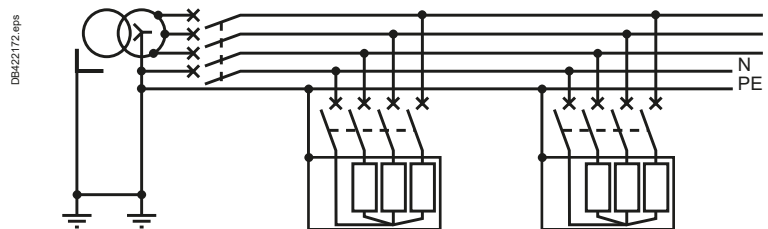


Fig. E14 TN-S system

1 Earthing schemes

Main characteristics

- Generally speaking, the TN system:
 - requires the installation of earth electrodes at regular intervals throughout the installation
 - Requires that the initial check on effective tripping for the first insulation fault be carried out by calculations during the design stage, followed by mandatory measurements to confirm tripping during commissioning
 - Requires that any modification or extension be designed and carried out by a qualified electrician
 - May result, in the case of insulation faults, in greater damage to the windings of rotating machines
 - May, on premises with a risk of fire, represent a greater danger due to the higher fault currents
- In addition, the TN-C system:
 - At first glance, would appear to be less expensive (elimination of a device pole and of a conductor)
 - Requires the use of fixed and rigid conductors
 - Is forbidden in certain cases:
 - Premises with a risk of fire
 - For computer equipment (presence of harmonic currents in the neutral)
- In addition, the TN-S system:
 - May be used even with flexible conductors and small conduits
 - Due to the separation of the neutral and the protection conductor, provides a clean PE (computer systems and premises with special risks).

IT system:

- Protection technique:
 - Interconnection and earthing of exposed conductive parts
 - Indication of the first fault by an insulation monitoring device (IMD)
 - Interruption for the second fault using overcurrent protection (circuit breakers or fuses)
- Operating technique:
 - Monitoring of the first insulation fault
 - Mandatory location and clearing of the fault
 - Interruption for two simultaneous insulation faults

IT system (see Fig. E15)

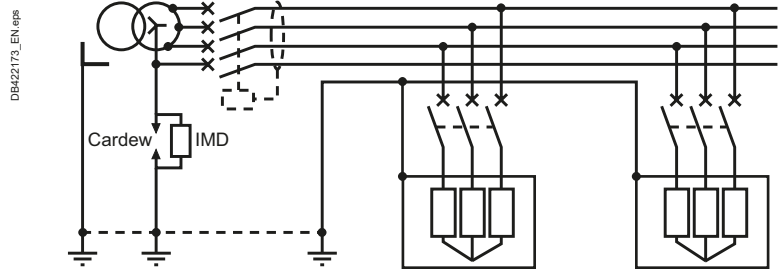


Fig. E15 IT system

Main characteristics

- Solution offering the best continuity of service during operation
- Indication of the first insulation fault, followed by mandatory location and clearing, ensures systematic prevention of supply outages
- Generally used in installations supplied by a private MV/LV or LV/LV transformer
- Requires maintenance personnel for monitoring and operation
- Requires a high level of insulation in the network (implies breaking up the network if it is very large and the use of circuit-separation transformers to supply loads with high leakage currents)
- The check on effective tripping for two simultaneous faults must be carried out by calculations during the design stage, followed by mandatory measurements during commissioning on each group of interconnected exposed conductive parts
- Protection of the neutral conductor must be ensured as indicated in section 7.2 of **Chapter G**.

1 Earthing schemes

Selection does not depend on safety criteria.
The three systems are equivalent in terms of protection of persons if all installation and operating rules are correctly followed. The selection criteria for the best system(s) depend on the regulatory requirements, the required continuity of service, operating conditions and the types of network and loads.

1.4 Selection criteria for the TT, TN and IT systems

In terms of the protection of persons, the three system earthing arrangements (SEA) are equivalent if all installation and operating rules are correctly followed. Consequently, selection does not depend on safety criteria.

It is by combining all requirements in terms of regulations, continuity of service, operating conditions and the types of network and loads that it is possible to determine the best system(s) (see Fig. E16).

Selection is determined by the following factors:

- Above all, the applicable regulations which in some cases impose certain types of SEA
- Secondly, the decision of the owner if supply is via a private MV/LV transformer (MV subscription) or the owner has a private energy source (or a separate-winding transformer).

If the owner effectively has a choice, the decision on the SEA is taken following discussions with the network designer (design office, contractor).

The discussions must cover:

- First of all, the operating requirements (the required level of continuity of service) and the operating conditions (maintenance ensured by electrical personnel or not, in-house personnel or outsourced, etc.)
- Secondly, the particular characteristics of the network and the loads (see Fig. E17 next page).

	TT	TN-S	TN-C	IT1 ^[a]	IT2 ^[b]	Comments
Electrical characteristics						
Fault current	-	--	--	+	--	Only the IT system offers virtually negligible first-fault currents
Fault voltage	-	-	-	+	-	In the IT system, the touch voltage is very low for the first fault, but is considerable for the second
Touch voltage	+/-	-	-	+	-	In the TT system, the touch voltage is very low if system is equipotential, otherwise it is high
Protection						
Protection of persons against indirect contact	+	+	+	+	+	All SEAs (system earthing arrangement) are equivalent, if the rules are followed
Protection of persons with emergency generating sets	+	-	-	+	-	Systems where protection is ensured by RCDs are not sensitive to a change in the internal impedance of the source
Protection against fire (with an RCD)	+	+	Not allowed	+	+	All SEAs in which RCDs can be used are equivalent. The TN-C system is forbidden on premises where there is a risk of fire
Overvoltages						
Continuous overvoltage	+	+	+	-	+	A phase-to-earth overvoltage is continuous in the IT system if there is a first insulation fault
Transient overvoltage	+	-	-	+	-	Systems with high fault currents may cause transient overvoltages
Overvoltage if transformer breakdown (primary/secondary)	-	+	+	+	+	In the TT system, there is a voltage imbalance between the different earth electrodes. The other systems are interconnected to a single earth electrode
Electromagnetic compatibility						
Immunity to nearby lightning strikes	-	+	+	+	+	In the TT system, there may be voltage imbalances between the earth electrodes. In the TT system, there is a significant current loop between the two separate earth electrodes
Immunity to lightning strikes on MV lines	-	-	-	-	-	All SEAs are equivalent when a MV line takes a direct lightning strike
Continuous emission of an electromagnetic field	+	+	-	+	+	Connection of the PEN to the metal structures of the building is conducive to the continuous generation of electromagnetic fields
Transient non-equipotentiality of the PE	+	-	-	+	-	The PE is no longer equipotential if there is a high fault current
Continuity of service						
Interruption for first fault	-	-	-	+	+	Only the IT system avoids tripping for the first insulation fault
Voltage dip during insulation fault	+	-	-	+	-	The TN-S, TNC and IT (2nd fault) systems generate high fault currents which may cause phase voltage dips
Installation						
Special devices	-	+	+	-	-	The TT system requires the use of RCDs. The IT system requires the use of IMDs
Number of earth electrodes	-	+	+	-/+	-/+	The TT system requires two distinct earth electrodes. The IT system offers a choice between one or two earth electrodes
Number of cables	-	-	+	-	-	Only the TN-C system offers, in certain cases, a reduction in the number of cables
Maintenance						
Cost of repairs	-	--	--	-	--	The cost of repairs depends on the damage caused by the amplitude of the fault currents
Installation damage	+	-	-	++	-	Systems causing high fault currents require a check on the installation after clearing the fault

[a] IT-net when a first fault occurs.

[b] IT-net when a second fault occurs.

Fig. E16 Comparison of system earthing arrangements

1 Earthing schemes

Type of network		Advised	Possible	Not advised
Very large network with high-quality earth electrodes for exposed conductive parts (10 Ω max.)			TT, TN, IT ^[a] or mixed	
Very large network with low-quality earth electrodes for exposed conductive parts (> 30 Ω)		TN	TN-S	IT[A] TN-C
Disturbed area (storms) (e.g. television or radio transmitter)		TN	TT	IT ^[b]
Network with high leakage currents (> 500 mA)		TN ^[d]	IT ^[d] TT ^[c] [d]	
Network with outdoor overhead lines		TT ^[e]	TN ^[e] [f]	IT ^[f]
Emergency standby generator set		IT	TT	TN ^[g]
Type of loads				
Loads sensitive to high fault currents (motors, etc.)		IT	TT	TN ^[h]
Loads with a low insulation level (electric furnaces, welding machines, heating elements, immersion heaters, equipment in large kitchens)		TN ^[i]	TT ^[i]	IT
Numerous phase-neutral single-phase loads (mobile, semi-fixed, portable)		TT ^[j] TN-S		IT ^[j] TN-C ^[j]
Loads with sizeable risks (hoists, conveyers, etc.)		TN ^[k]	TT ^[k]	IT ^[k]
Numerous auxiliaries (machine tools)		TN-S	TN-C IT ^{[l]bis}	TT ^[l]
Miscellaneous				
Supply via star-star connected power transformer[m]		TT	IT without neutral	IT ^[m] without neutral
Premises with risk of fire		IT ^[o]	TN-S ^[o] TT ^[o]	TN-C ^[n]
Increase in power level of LV utility subscription, requiring a private substation		TT ^[p]		
Installation with frequent modifications		TT ^[q]		TN ^[r] IT ^[r]
Installation where the continuity of earth circuits is uncertain (work sites, old installations)		TT ^[s]	TN-S	TN-C IT ^[s]
Electronic equipment (computers, PLCs)		TN-S		TN-C
Machine control-monitoring network, PLC sensors and actuators		IT ^[t]	TN-S, TT	

E9

[a] When the SEA is not imposed by regulations, it is selected according to the level of operating characteristics (continuity of service that is mandatory for safety reasons or desired to enhance productivity, etc.)

Whatever the SEA, the probability of an insulation failure increases with the length of the network. It may be a good idea to break up the network, which facilitates fault location and makes it possible to implement the system advised above for each type of application.

[b] The risk of flashover on the surge limiter turns the isolated neutral into an earthed neutral. These risks are high for regions with frequent thunder storms or installations supplied by overhead lines. If the IT system is selected to ensure a higher level of continuity of service, the system designer must precisely calculate the tripping conditions for a second fault.

[c] Risk of RCD nuisance tripping.

[d] Whatever the SEA, the ideal solution is to isolate the disturbing section if it can be easily identified.

[e] Risks of phase-to-earth faults affecting equipotentiality.

[f] Insulation is uncertain due to humidity and conducting dust.

[g] The TN system is not advised due to the risk of damage to the generator in the case of an internal fault. What is more, when generator sets supply safety equipment, the system must not trip for the first fault.

[h] The phase-to-earth current may be several times higher than I_n , with the risk of damaging or accelerating the ageing of motor windings, or of destroying magnetic circuits.

[i] To combine continuity of service and safety, it is necessary and highly advised, whatever the SEA, to separate these loads from the rest of the installation (transformers with local neutral connection).

[j] When load equipment quality is not a design priority, there is a risk that the insulation resistance will fall rapidly. The TT system with RCDs is the best means to avoid problems.

[k] The mobility of this type of load causes frequent faults (sliding contact for bonding of exposed conductive parts) that must be countered. Whatever the SEA, it is advised to supply these circuits using transformers with a local neutral connection.

[l] Requires the use of transformers with a local TN system to avoid operating risks and nuisance tripping at the first fault (TT) or a double fault (IT).

[l]bis] With a double break in the control circuit.

[m] Excessive limitation of the phase-to-neutral current due to the high value of the zero-phase impedance (at least 4 to 5 times the direct impedance). This system must be replaced by a star-delta arrangement.

[n] The high fault currents make the TN system dangerous. The TN-C system is forbidden.

[o] Whatever the system, the RCD must be set to Δn y 500 mA.

[p] An installation supplied with LV energy must use the TT system. Maintaining this SEA means the least amount of modifications on the existing network (no cables to be run, no protection devices to be modified).

[q] Possible without highly competent maintenance personnel.

[r] This type of installation requires particular attention in maintaining safety. The absence of preventive measures in the TN system means highly qualified personnel are required to ensure safety over time.

[s] The risks of breaks in conductors (supply, protection) may cause the loss of equipotentiality for exposed conductive parts. A TT system or a TN-S system with 30 mA RCDs is advised and is often mandatory. The IT system may be used in very specific cases.

[t] This solution avoids nuisance tripping for unexpected earth leakage.

Fig. E17 Influence of networks and loads on the selection of system earthing arrangements

1 Earthing schemes

E10

1.5 Choice of earthing method - implementation

After consulting applicable regulations, **Figures E16** and **E17** can be used as an aid in deciding on divisions and possible galvanic isolation of appropriate sections of a proposed installation.

Division of source

This technique concerns the use of several transformers instead of employing one high-rated unit. In this way, a load that is a source of network disturbances (large motors, furnaces, etc.) can be supplied by its own transformer.

The quality and continuity of supply to the whole installation are thereby improved.

The cost of switchgear is reduced (short-circuit current level is lower).

The cost-effectiveness of separate transformers must be determined on a case by case basis.

Network islands

The creation of galvanically-separated “islands” by means of LV/LV transformers makes it possible to optimise the choice of earthing methods to meet specific requirements (see **Fig. E18** and **Fig. E19**).

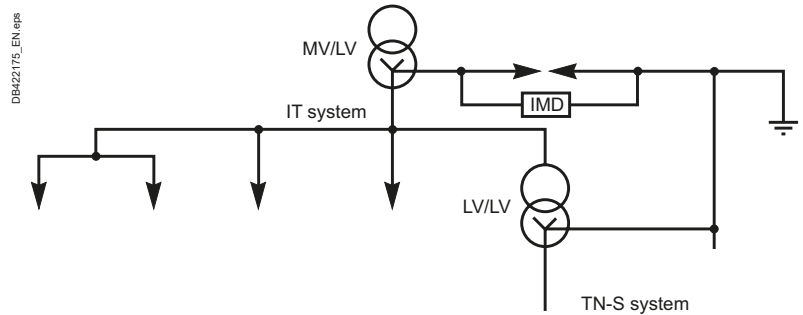


Fig. E18 TN-S island within an IT system

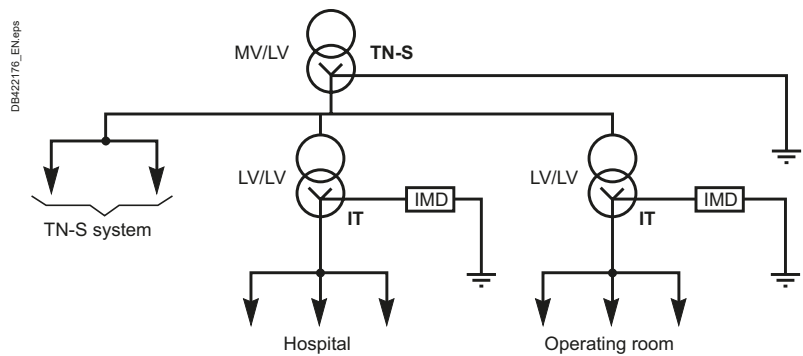


Fig. E19 IT islands within a TN-S system

Conclusion

The optimisation of the performance of the whole installation governs the choice of earthing system.

Including:

- Initial investments, and
- Future operational expenditures, hard to assess, that can arise from insufficient reliability, quality of equipment, safety, continuity of service, etc.

An ideal structure would comprise normal power supply sources, local reserve power supply sources (see section 1.4 of Chapter E) and the appropriate earthing arrangements.

1 Earthing schemes

A very effective method of obtaining a low-resistance earth connection is to bury a conductor in the form of a closed loop in the soil at the bottom of the excavation for building foundations.

The resistance R of such an electrode (in homogeneous soil) is given (approximately)

in ohms by: $R = \frac{2\rho}{L}$ where
 L = length of the buried conductor in metres
 ρ = soil resistivity in ohm-metres

1.6 Installation and measurements of earth electrodes

The quality of an earth electrode (resistance as low as possible) depends essentially on two factors:

- Installation method
- Type of soil.

Installation methods

Three common types of installation will be discussed:

Buried ring (see Fig. E20)

This solution is strongly recommended, particularly in the case of a new building. The electrode should be buried around the perimeter of the excavation made for the foundations. It is important that the bare conductor be in intimate contact with the soil (and not placed in the gravel or aggregate hard-core, often forming a base for concrete). At least four (widely-spaced) vertically arranged conductors from the electrode should be provided for the installation connections and, where possible, any reinforcing rods in concrete work should be connected to the electrode.

The conductor forming the earth electrode, particularly when it is laid in an excavation for foundations, must be in the earth, at least 50 cm below the hard-core or aggregate base for the concrete foundation. Neither the electrode nor the vertical rising conductors to the ground floor, should ever be in contact with the foundation concrete.

For existing buildings, the electrode conductor should be buried around the outside wall of the premises to a depth of at least 1 metre. As a general rule, all vertical connections from an electrode to above-ground level should be insulated for the nominal LV voltage (600-1000 V).

The conductors may be:

- Copper: Bare cable (≥ 25 mm²) or multiple-strip (≥ 25 mm² and ≥ 2 mm thick)
- Aluminium with lead jacket: Cable (≥ 35 mm²)
- Galvanised-steel cable: Bare cable (≥ 95 mm²) or multiple-strip (≥ 100 mm² and ≥ 3 mm thick).

The approximate resistance R of the electrode in ohms:

$$R = \frac{2\rho}{L}$$

where

L = length of conductor in metres

ρ = resistivity of the soil in ohm-metres (see "Influence of the type of soil" next page).

Earthing rods (see Fig. E21)

Vertically driven earthing rods are often used for existing buildings, and for improving (i.e. reducing the resistance of) existing earth electrodes.

The rods may be:

- Copper or (more commonly) copper-clad steel. The latter are generally 1 or 2 metres long and provided with screwed ends and sockets in order to reach considerable depths, if necessary (for instance, the water-table level in areas of high soil resistivity)
- Galvanised (see note (1) next page) steel pipe ≥ 25 mm diameter or rod ≥ 15 mm diameter, ≥ 2 metres long in each case.

For n rods: $R = \frac{1}{n} \frac{\rho}{L}$

DB42177.eps

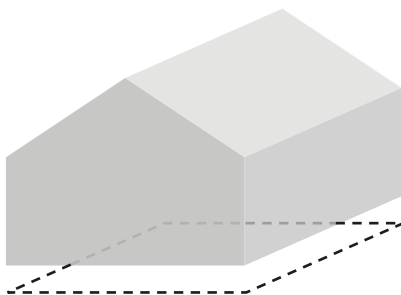


Fig. E20 Conductor buried below the level of the foundations, i.e. not in the concrete

DB42178.eps

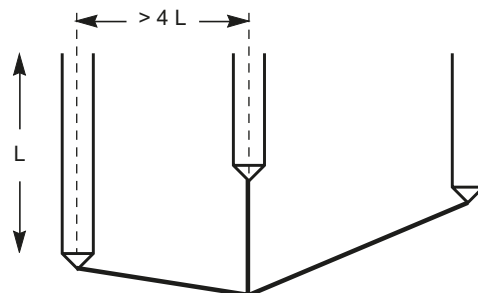


Fig. E21 Earthing rods connected in parallel

E11

1 Earthing schemes

E12

DB422173 eps

For a vertical plate electrode: $R = \frac{0.8 \rho}{L}$

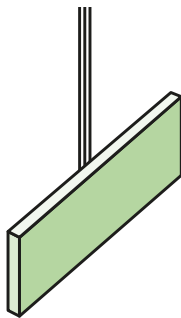


Fig. E22 Vertical plate - 2 mm thickness (Cu)

Measurements on earth electrodes in similar soils are useful to determine the resistivity value to be applied for the design of an earth-electrode system

It is often necessary to use more than one rod, in which case the spacing between them should exceed the depth to which they are driven, by a factor of 2 to 3.

The total resistance (in homogeneous soil) is then equal to the resistance of one rod, divided by the number of rods in question. The approximate resistance R obtained is:

$$R = \frac{1 \rho}{n L} \text{ if the distance separating the rods } > 4 L$$

where

L = the length of the rod in metres

ρ = resistivity of the soil in ohm-metres (see "Influence of the type of soil" below)

n = the number of rods.

Vertical plates (see Fig. E22)

Rectangular plates, each side of which must be ≥ 0.5 metres, are commonly used as earth electrodes, being buried in a vertical plane such that the centre of the plate is at least 1 metre below the surface of the soil.

The plates may be:

- Copper of 2 mm thickness
- Galvanised [1] steel of 3 mm thickness

The resistance R in ohms is given (approximately), by:

$$R = \frac{0.8 \rho}{L}$$

L = the perimeter of the plate in metres

ρ = resistivity of the soil in ohm-metres (see "Influence of the type of soil" below).

Influence of the type of soil

Type of soil	Mean value of resistivity in Ωm
Swampy soil, bogs	1 - 30
Silt alluvium	20 - 100
Humus, leaf mould	10 - 150
Peat, turf	5 - 100
Soft clay	50
Marl and compacted clay	100 - 200
Jurassic marl	30 - 40
Clayey sand	50 - 500
Siliceous sand	200 - 300
Stoney ground	1500 - 3000
Grass-covered-stoney sub-soil	300 - 500
Chalky soil	100 - 300
Limestone	1000 - 5000
Fissured limestone	500 - 1000
Schist, shale	50 - 300
Mica schist	800
Granite and sandstone	1500 - 10000
Modified granite and sandstone	100 - 600

Fig. E23 Resistivity (Ωm) for different types of soil

Type of soil	Mean value of resistivity in Ωm
Fertile soil, compacted damp fill	50
Arid soil, gravel, uncompacted non-uniform fill	500
Stoney soil, bare, dry sand, fissured rocks	3000

Fig. E24 Average resistivity values (Ωm) for an approximate sizing of earth-electrode

[1] Where galvanised conducting materials are used for earth electrodes, sacrificial cathodic protection anodes may be necessary to avoid rapid corrosion of the electrodes where the soil is aggressive. Specially prepared magnesium anodes (in a porous sack filled with a suitable "soil") are available for direct connection to the electrodes. In such circumstances, a specialist should be consulted

1 Earthing schemes

Measurement and constancy of the resistance between an earth electrode and the earth

The resistance of the electrode/earth interface rarely remains constant

Among the principal factors affecting this resistance are the following:

■ Humidity of the soil

The seasonal changes in the moisture content of the soil can be significant at depths of up to 2 meters.

At a depth of 1 metre the resistivity and therefore the resistance can vary by a ratio of 1 to 3 between a wet winter and a dry summer in temperate regions

■ Frost

Frozen earth can increase the resistivity of the soil by several orders of magnitude. This is one reason for recommending the installation of deep electrodes, in particular in cold climates

■ Ageing

The materials used for electrodes will generally deteriorate to some extent for various reasons, for example:

□ Chemical reactions (in acidic or alkaline soils)

□ Galvanic: due to stray DC currents in the earth, for example from electric railways, etc. or due to dissimilar metals forming primary cells. Different soils acting on sections of the same conductor can also form cathodic and anodic areas with consequent loss of surface metal from the latter areas. Unfortunately, the most favourable conditions for low earth-electrode resistance (i.e. low soil resistivity) are also those in which galvanic currents can most easily flow.

■ Oxidation

Brazed and welded joints and connections are the points most sensitive to oxidation. Thorough cleaning of a newly made joint or connection and wrapping with a suitable greased-tape binding is a commonly used preventive measure.

Measurement of the earth-electrode resistance

There must always be one or more removable links to isolate an earth electrode so that it can be tested.

There must always be removable links which allow the earth electrode to be isolated from the installation, so that periodic tests of the earthing resistance can be carried out. To make such tests, two auxiliary electrodes are required, each consisting of a vertically driven rod.

■ Ammeter method (see Fig. E25).

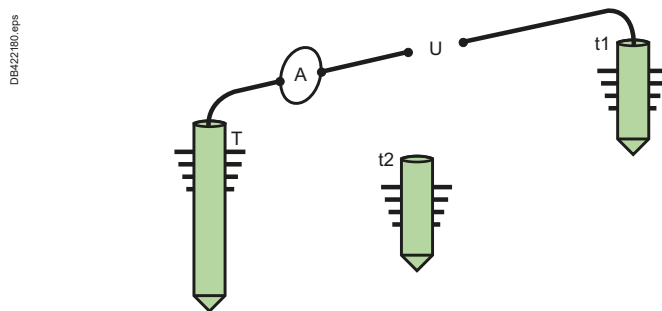


Fig. E25 Measurement of the resistance to earth of the earth electrode of an installation by means of an ammeter

$$A = R_T + R_{t1} = \frac{U_{Tt1}}{i_1}$$

$$B = R_{t1} + R_{t2} = \frac{U_{t1t2}}{i_2}$$

$$C = R_{t2} + R_T = \frac{U_{t2T}}{i_3}$$

When the source voltage U is constant (adjusted to be the same value for each test) then:

$$R_T = \frac{U}{2} \left(\frac{1}{i_1} + \frac{1}{i_3} - \frac{1}{i_2} \right)$$

1 Earthing schemes

E14

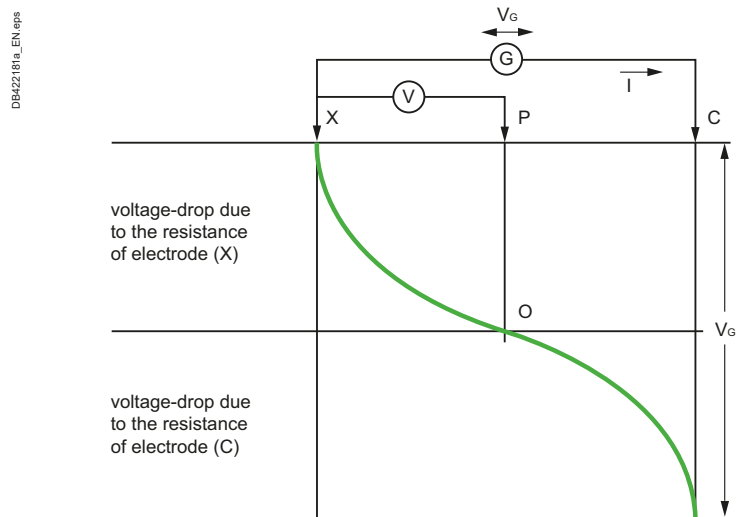
In order to avoid errors due to stray earth currents (galvanic -DC- or leakage currents from power and communication networks and so on) the test current should be AC, but at a different frequency to that of the power system or any of its harmonics. Instruments using hand-driven generators to make these measurements usually produce an AC voltage at a frequency of between 85 Hz and 135 Hz.

The distances between the electrodes are not critical and may be in different directions from the electrode being tested, according to site conditions. A number of tests at different spacings and directions are generally made to cross-check the test results.

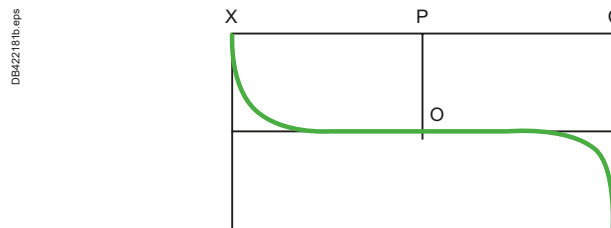
■ Use of a direct-reading earthing-resistance ohmmeter

These instruments use a hand-driven or electronic-type AC generator, together with two auxiliary electrodes, the spacing of which must be such that the zone of influence of the electrode being tested should not overlap that of the test electrode (C). The test electrode (C) furthest from the electrode (X) under test, passes a current through the earth and the electrode under test, while the second test electrode (P) picks up a voltage. This voltage, measured between (X) and (P), is due to the test current and is a measure of the contact resistance (of the electrode under test) with earth. It is clear that the distance (X) to (P) must be carefully chosen to give accurate results. If the distance (X) to (C) is increased, however, the zones of resistance of electrodes (X) and (C) become more remote, one from the other, and the curve of potential (voltage) becomes more nearly horizontal about the point (O).

In practical tests, therefore, the distance (X) to (C) is increased until readings taken with electrode (P) at three different points, i.e. at (P) and at approximately 5 metres on either side of (P), give similar values. The distance (X) to (P) is generally about 0.68 of the distance (X) to (C).



a) the principle of measurement is based on assumed homogeneous soil conditions. Where the zones of influence of electrodes C and X overlap, the location of test electrode P is difficult to determine for satisfactory results.



b) showing the effect on the potential gradient when (X) and (C) are widely spaced. The location of test electrode P is not critical and can be easily determined.

Fig. E26 Measurement of the resistance to the mass of earth of electrode (X) using an earth-electrode-testing ohmmeter

2 The installation system

Distribution switchboards, including the main LV switchboard (MLVS), are critical to the dependability of an electrical installation. They must comply with well-defined standards governing the design and construction of LV switchgear assemblies

The load requirements dictate the type of distribution switchboard to be installed

2.1 Distribution switchboards

A distribution switchboard is the point at which an incoming-power supply divides into separate circuits, each of which is controlled and protected by the fuses or switchgear of the switchboard. A distribution switchboard is divided into a number of functional units, each comprising all the electrical and mechanical elements that contribute to the fulfilment of a given function. It represents a key link in the dependability chain.

Consequently, the type of distribution switchboard must be perfectly adapted to its application. Its design and construction must comply with applicable standards and working practises.

The distribution switchboard enclosure provides dual protection:

- Protection of switchgear, indicating instruments, relays, fusegear, etc. against mechanical impacts, vibrations and other external influences likely to interfere with operational integrity (EMI, dust, moisture, vermin, etc.)
- The protection of human life against the possibility of direct and indirect electric shock (see degree of protection IP and the IK index in section 3.3 of **Chapter E**).

E15

2.1.1 Types of distribution switchboards

Distribution switchboards may differ according to the kind of application and the design principle adopted (notably in the arrangement of the busbars).

Distribution switchboards according to specific applications

The principal types of distribution switchboards are:

- The main LV switchboard - MLVS - (see **Fig. E27a**)
- Motor control centres - MCC - (see **Fig. E27b**)
- Sub-distribution switchboards (see **Fig. E28**)
- Final distribution switchboards (see **Fig. E29**).

Distribution switchboards for specific applications (e.g. heating, lifts, industrial processes) can be located:

- Adjacent to the main LV switchboard, or
- Near the application concerned.

Sub-distribution and final distribution switchboards are generally distributed throughout the site.



Fig. E27 [a] A main LV switchboard - MLVS - (Prisma P) with incoming circuits in the form of busways - [b] ALV motor control centre - MCC - (Okken)



Fig. E28 A sub-distribution switchboard (Prisma G)

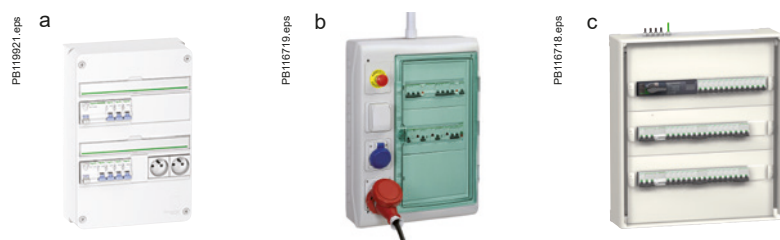


Fig. E29 Final distribution switchboards [a] Resi9; [b] Kaedra; [c] Prisma Pack 160

2 The installation system

A distinction is made between:

- Universal distribution switchboards in which switchgear and fusegear, etc. are fixed to a chassis at the rear of an enclosure
- Functional distribution switchboards for specific applications, based on modular and standardised design.

2.1.2 Two technologies of distribution switchboards

Universal distribution switchboards

Switchgear and fusegear, etc. are normally located on a chassis at the rear of the enclosure. Indications and control devices (meters, lamps, pushbuttons, etc.) are mounted on the front face of the switchboard.

The placement of the components within the enclosure requires very careful study, taking into account the dimensions of each item, the connections to be made to it, and the clearances necessary to ensure safe and trouble-free operation.

Functional distribution switchboards

Generally dedicated to specific applications, these distribution switchboards are made up of functional modules that include switchgear devices together with standardised accessories for mounting and connections, ensuring a high level of reliability and a great capacity for last-minute and future changes.

■ Many advantages

The use of functional distribution switchboards has spread to all levels of LV electrical distribution, from the main LV switchboard (MLVS) to final distribution switchboards, due to their many advantages:

- System modularity that makes it possible to integrate numerous functions in a single distribution switchboard, including protection, control, technical management and monitoring of electrical installations. Modular design also enhances distribution switchboard maintenance, operation and upgrades
- Distribution switchboard design is fast because it simply involves adding functional modules
- Prefabricated components can be mounted faster
- Finally, these distribution switchboards are subjected to type tests that ensure a high degree of dependability.

The Prisma G and P ranges of functional distribution switchboards from Schneider Electric cover needs up to 3200 A and offer:

- Flexibility and ease in building distribution switchboards
- Certification of a distribution switchboard complying with standard IEC 61439 and the assurance of servicing under safe conditions
- Time savings at all stages, from design to installation, operation and modifications or upgrades
- Easy adaptation, for example to meet the specific work habits and standards in different countries

Fig. E27a, Fig. E28 and Fig. E29 show examples of functional distribution switchboards ranging for all power ratings and **Fig. E27b** shows a high-power industrial functional distribution switchboard.

■ Main types of functional units

Three basic technologies are used in functional distribution switchboards.

□ Fixed functional units (see **Fig. E30**)

These units cannot be isolated from the supply so that any intervention for maintenance, modifications and so on, requires the shutdown of the entire distribution switchboard. Plug-in or withdrawable devices can however be used to minimise shutdown times and improve the availability of the rest of the installation.

□ Disconnectable functional units (see **Fig. E31**)

Each functional unit is mounted on a removable mounting plate and provided with a means of isolation on the upstream side (busbars) and disconnecting facilities on the downstream (outgoing circuit) side. The complete unit can therefore be removed for servicing, without requiring a general shutdown.

□ Drawer-type withdrawable functional units (see **Fig. E32**)

The switchgear and associated accessories for a complete function are mounted on a drawer-type horizontally withdrawable chassis. The function is generally complex and often concerns motor control.

Isolation is possible on both the upstream and downstream sides by the complete withdrawal of the drawer, allowing fast replacement of a faulty unit without derging the rest of the distribution switchboard.

E16

PB116721.eps



Fig. E30 Assembly of a final distribution switchboard with fixed functional units (Prisma G)

PB116722.eps



Fig. E31 Distribution switchboard with disconnectable functional units

PB116723.eps



Fig. E32 Distribution switchboard with withdrawable functional units in drawers

2 The installation system

Compliance with applicable standards is essential in order to ensure an adequate degree of dependability

Three elements of standards IEC 61439-1 & 2 contribute significantly to dependability:

- Clear definition of functional units
- Forms of separation between adjacent functional units in accordance with user requirements
- Clearly defined verification tests and routine verification

2.1.3 Standards IEC 61439

The IEC standard series 61439 («Low-voltage switchgear and controlgear assemblies») have been developed in order to provide to the End-Users of switchboards a high level of confidence in terms of **safety** and **power availability**.

Safety aspects include:

- Safety of people (risk of electrocution),
- Risk of fire,
- Risk of explosion.

Power availability is a major issue in many activity sectors, with high possible economical impact in case of long interruption consecutive to a switchboard failure.

The standards give the design and verification requirements so that no failure should be expected in case of fault, disturbance, or operation in severe environment conditions.

Compliance to the standards shall ensure that the switchboard will operate correctly not only in normal conditions, but also in difficult conditions.

E17

Standard structure

The IEC 61439 standard series consist in one base standard (IEC 61439-1) giving the general rules, and several related standards detailing which of these general rules apply (or not, or should be adapted) for specific types of assemblies:

- IEC/TR 61439-0 : Guidance to specifying assemblies
- IEC 61439-1: General rules
- IEC 61439-2: Power switchgear and controlgear assemblies
- IEC 61439-3: Distribution boards intended to be operated by ordinary persons (DBO)
- IEC 61439-4: Particular requirements for assemblies for construction sites (ACS)
- IEC 61439-5: Assemblies for power distribution in public networks
- IEC 61439-6: Busbar trunking systems (busways)
- IEC/TS 61439-7: Assemblies for specific applications such as marinas, camping sites, market squares, electric vehicles charging stations.

The first edition (IEC 61439-1 and 2) of these documents has been published in 2009, with a revision in 2011.

Major improvements with IEC61439 standard

Compared to the previous series IEC60439, several major improvements have been introduced, for the benefit of the End-User.

Requirements based on End-User expectations

The different requirements included in the standards have been introduced in order to fulfil the End-User expectations:

- Capability to operate the electrical installation,
- Voltage stress withstand capability,
- Current carrying capability,
- Short-circuit withstand capability,
- Electro-Magnetic Compatibility,
- Protection against electric shock,
- Maintenance and modifying capabilities,
- Ability to be installed on site,
- Protection against risk of fire,
- Protection against environmental conditions.

2 The installation system

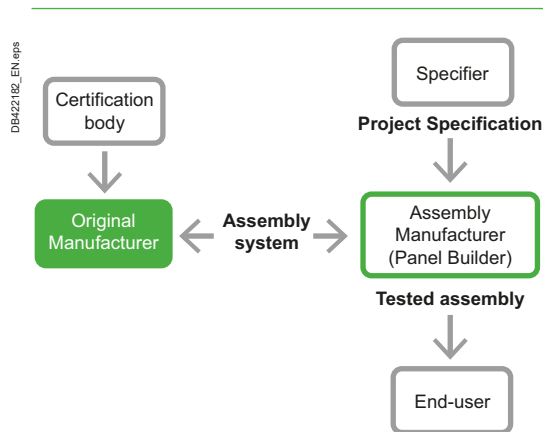


Fig. E33 Main actors and responsibilities, as defined by the IEC 61439-1&2 standard

Clear definition of responsibilities

The role of the different actors has been clearly defined, and can be summarized by the following **Fig. E33**.

Switchboards are qualified as **Assembly**, including switching devices, control, measuring, protective, regulating equipment, with all the internal electrical and mechanical interconnections and structural parts. **Assembly systems** include mechanical and electrical components (enclosures, busbars, functional units, etc.).

The **original manufacturer** is the organization that has carried out the original design and the associated verification of an assembly in accordance with the relevant standard. He is responsible for the **Design verifications** listed by IEC 61439-2 including many electrical tests.

The verification may be supervised by a **Certification body**, providing certificates to the Original Manufacturer. These certificates can be conveyed to the **Specifier** or End-User at their request.

The **assembly manufacturer**, generally a Panel Builder, is the organization taking responsibility for the completed assembly. The assembly must be completed according to the original manufacturer's instructions. If the assembly manufacturer deviates from the instructions of the original manufacturer he has to carry out again new design verifications.

Such deviations should also be submitted to the original manufacturer for validation.

At the end of assembly, **routine verifications** must be carried out by the assembly manufacturer (Panel-builder).

The result is a fully tested assembly, for which design verifications have been carried out by the original manufacturer, and routine verifications carried out by the assembly manufacturer.

This procedure gives a better visibility to the end-user, compared to the "**Partially Type Tested**" and "**Totally Type Tested**" approach proposed by the previous IEC60439 series.

Clarifications of design verification, new or updated design requirements and routine verifications

The IEC61439 standards also include:

- updated or new **design requirements** (example: new lifting test)
- highly clarified **design verifications** to be made, and the acceptable methods which can be used (or not) to do these verifications, for each type of requirement. **See Fig. E34** for more details
- a more detailed list of **routine verifications**, and more severe requirements for clearances.

The following paragraphs provide details on these evolutions.

Design requirements

For an Assembly System or switchboard to be compliant with the standards, different

requirements are applicable. These requirements are of 2 types:

- **Constructional** requirements
- **Performance** requirements.

See **Fig. E34** in "design verification" paragraph for the detailed list of requirements.

The design of the assembly system must follow these requirements, under the responsibility of the **original manufacturer**.

Design verification

Design verification, under the responsibility of the **original manufacturer**, is intended to verify compliance of the design of an assembly or assembly system with the requirements of this series of standards.

Design verification can be carried out by:

- **Testing**, which should be done on the most onerous variant (worst-case)
- **Calculation**, including use of appropriate safety margins
- **Comparison** with a tested reference design.

The IEC61439 standard have clarified a lot the definition of the different verification methods, and specifies very clearly which of these 3 methods can be used for each type of design verification, as shown in **Fig. E34**.

2 The installation system

No.	Characteristic to be verified	Clauses or subclauses	Verification options available		
			Testing	Comparison with a reference design	Assessment
1	Strength of material and parts:	10.2			
	Resistance to corrosion	10.2.2	YES	NO	NO
	Properties of insulating materials:	10.2.3			
	Thermal stability	10.2.3.1	YES	NO	NO
	Resistance to abnormal heat and fire due to internal electric effects	10.2.3.2	YES	NO	YES
	Resistance to ultra-violet (UV) radiation	10.2.4	YES	NO	YES
	Lifting	10.2.5	YES	NO	NO
	Mechanical impact	10.2.6	YES	NO	NO
	Marking	10.2.7	YES	NO	NO
2	Degree of protection of enclosures	10.3	YES	NO	YES
3	Clearances	10.4	YES	NO	NO
4	Creepage distances	10.4	YES	NO	NO
5	Protection against electric shock and integrity of protective circuits:	10.5			
	Effective continuity between the exposed conductive parts of the ASSEMBLY and the protective circuit	10.5.2	YES	NO	NO
	Short-circuit withstand strength of the protective circuit	10.5.3	YES	NO	NO
6	Incorporation of switching devices and components	10.6	NO	NO	YES
7	Internal electrical circuits and connections	10.7	NO	NO	YES
8	Terminals for external conductors	10.8	NO	NO	YES
9	Dielectric properties:	10.9			
	Power-frequency withstand voltage	10.9.2	YES	NO	NO
	Impulse withstand voltage	10.9.3	YES	NO	YES
10	Temperature-rise limits	10.10	YES	YES	YES ^[a]
11	Short-circuit withstand strength	10.11	YES	YES ^[b]	NO
12	Electromagnetic compatibility (EMC)	10.12	YES	NO	YES
13	Mechanical operation	10.13	YES	NO	NO

[a] Verification of temperature-rise limits by assessment (e.g. calculation) has been restricted and clarified with IEC61439 (2011) standard. As a synthesis:

■ for rated current ≤ 630 A and single compartment switchboards: calculation is permitted, based on a comparison between the total power losses of all the components inside the enclosure, and the power loss capability of the enclosure (measured by a test with heating resistors), and a mandatory 20% de-rating of the rated current of the circuits

■ for rated current ≤ 1600 A and switchboard with one or several compartments with maximum 3 horizontal partitions for every section: calculation is permitted based on IEC/TR 60890, but with a mandatory 20% de-rating of the rated current of the circuits.

■ for rated current > 1600 A, no calculation, only tests permitted

[b] Verification of short-circuit withstand strength by comparison with a reference design has been clarified with IEC61439 standard. In practice, in most cases it is mandatory to do this verification by testing (type-testing), and in any case **the comparison with a reference design is only possible for short-circuit protection devices of the same manufacturer**, and provided that all other elements of a very strict comparison checklist are verified (Table 13 – “Short-circuit verification by comparison with a reference design: check list” of IEC61439-1).

Fig. E34 List of design verifications to be performed, and verification options available (table D.1 of Annex D of IEC61439-1)

2 The installation system

Routine verification

Routine verification is intended to detect faults in materials and workmanship and to ascertain proper functioning of the manufactured assemblies. It is under the responsibility of the **Assembly Manufacturer** or **Panel Builder**. Routine verification is performed on each manufactured assembly or assembly system.

Check to be carried out:

Routine verification	Visual inspection	Tests
Degree of protection of enclosures	YES	
Clearances	YES	- if $D <$ minimum clearance: verification by an impulse voltage withstand test - if not evident by visual inspection to be larger than the minimum clearance (e.g. if $D <$ 1.5 times minimum clearance), verification shall be by physical measurement or by an impulse voltage withstand test
Creepage distances	YES	or measurement if visual inspection not applicable
Protection against electric shock and integrity of protective circuits	YES	random verification of tightness of the connections of protective circuit
Incorporation of built-in components	YES	
Internal electrical circuits and connections	YES	or random verification of tightness
Terminals for external conductors	-	number, type and identification of terminals
Mechanical operation	YES	effectiveness of mechanical actuating elements locks and interlocks, including those associated with removable parts
Dielectric properties	-	power-frequency dielectric test. For assemblies with incoming protection rated up to 250A, verification of insulation resistance by measurement is accepted.
Wiring, operational performance and function	YES	verification of completeness of information & markings, inspection of wiring and function test where relevant

Fig. E35 List of routine verifications to be performed

A precise approach

The IEC 61439 series introduces a precise approach, intended to give to switchboards the right level of quality and performance expected by End-Users.

Detailed design requirements are given, and a clear verification process is proposed, which differentiates design verification and routine verification.

Responsibilities are clearly defined between the original manufacturer, responsible for the design, and assembly manufacturer, responsible for assembly and delivery to the End-User.

Functional units

The same standard defines functional units:

- Part of an assembly comprising all the electrical and mechanical elements that contribute to the fulfilment of the same function
- The distribution switchboard includes an incoming functional unit and one or more functional units for outgoing circuits, depending on the operating requirements of the installation.

What is more, distribution switchboard technologies use functional units that may be fixed, disconnectable or withdrawable (see section 4.2 of **Chapter D** & **Fig. E30**, **Fig. E31**, **Fig. E32**).

Forms (see Fig. E36)

Separation of functional units within the assembly is provided by forms that are specified for different types of operation.

The various forms are numbered from 1 to 4 with variations labelled "a" or "b". Each step up (from 1 to 4) is cumulative, i.e. a form with a higher number includes the characteristics of forms with lower numbers. The standard distinguishes:

- Form 1: No separation
- Form 2: Separation of busbars from the functional units
- Form 3: Separation of busbars from the functional units and separation of all functional units, one from another, except at their output terminals
- Form 4: As for Form 3, but including separation of the outgoing terminals of all

2 The installation system

functional units, one from another.

The decision on which form to implement results from an agreement between the manufacturer and the user.

The Prima functional range offers solutions for forms 1, 2b, 3b, 4a, 4b.

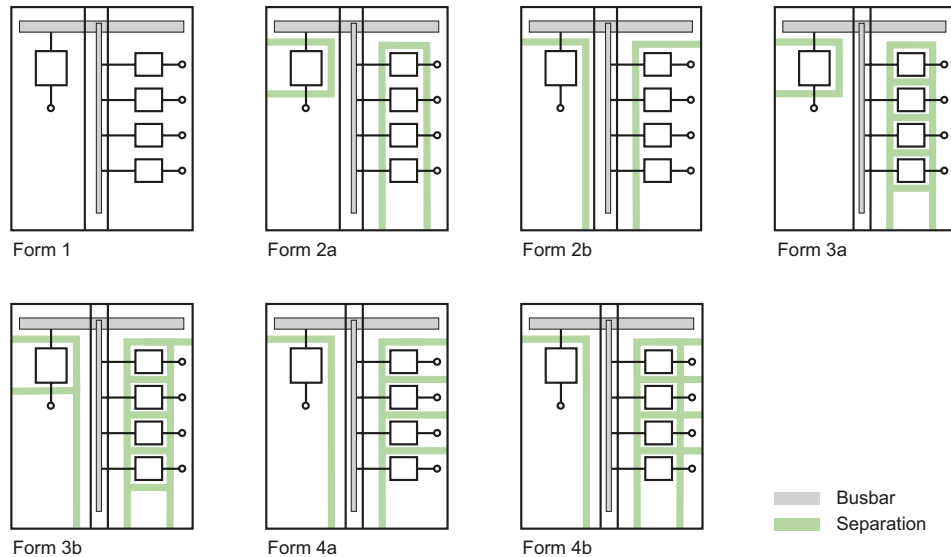


Fig. E36 Representation of different forms of LV functional distribution switchboards

Beyond the standard

Despite the improvements brought by the IEC 61439 series compared to the previous IEC 60439, there are still some limitations. In particular, for an Assembly manufacturer or Panel Builder combining equipment and devices from different sources (manufacturers), the design verification cannot be complete. All the different combinations of equipment from different sources cannot be tested at the design stage. With this approach, the compliance with the standard cannot be obtained in all particular configurations. Compliance is limited to a reduced number of configurations.

In this situation, End-users are encouraged to ask for test certificates corresponding to their particular configuration, and not only valid for generic configurations.

On the other hand, IEC 61439 sets strict limitation to the device substitution by a device from another series, for temperature rise and short-circuit withstand verification in particular. Only substitution of devices of the same make and series, i.e. same manufacturer and with the same or better limitation characteristics (I^2t , Ipk), can guarantee that the level of performance is maintained. As a consequence, substitution by another device not of same manufacturer can only be verified by testing (e.g. "type-testing") to comply to IEC61439 standard and guarantee the safety of the Assembly.

By contrast, in addition to the requirements given by the IEC 61439 series, a **full system** approach as proposed by a manufacturer like Schneider Electric provides a maximum level of confidence. All the different parts of the assembly are provided by the Original Manufacturer. Not only generic combinations are tested, but all the possible combinations permitted by the Assembly design are tested and verified.

The high level of performance is obtained through **Protection Coordination**, where the combined operation of protective and switching devices with internal electrical and mechanical interconnections and structural parts is guaranteed. All these devices have been consistently designed with this objective in mind. All the relevant device combinations are tested. There is less risk left compared with assessment through calculations or based only on catalogued data. (Protection coordination is further explained in chapter H of this Guide.).

Only the full system approach can provide the necessary peace of mind to the End-user, whatever the possible disturbance in his electrical installation.

2 The installation system

2.1.4 Internal arc withstand tests

International standard IEC 61439-2 ^[1] enables the design and manufacturing of reliable assemblies, and ensures high energy availability. However, there is always a risk, however very limited, of an internal arc-fault during the operating life of the assemblies. For example, this can be due to:

- conductive materials accidentally left in the assemblies during manufacture, installation or maintenance
- entry of small animals, e.g. mouse, snake, ...
- material default or inadequate personnel qualification
- lack of maintenance
- abnormal operating conditions that cause overheating, and eventually an internal arc-fault;

The ignition of an arc inside an assembly generates various physical phenomena, causes very high overheating (thermal avalanche) and especially high overpressure inside the enclosure, which endanger people in the close proximity of the assembly (doors sudden opening, projection of hot materials or gases outside the enclosure ...).

To evaluate the capability of an assembly to sustain internal overpressures, publication IEC/TR 61641 ^[2] (which is a technical report) has been drafted. It provides a common reference with a standardized method for tests, as well as criteria for the validation of tests results.

IEC/TR 61641 assesses the ability of an assembly to limit the risk of personal injury and damage to the assemblies, as well as the downtime and time needed to return to service after an arc due to an internal fault.

It is important to note that this is a voluntary test done at the discretion of the manufacturer and in agreement with the customer. Internal arc performance could be evaluated, for example, in the following cases:

- assemblies for applications requiring a high-level continuity of service
- assemblies for buildings considered as critical
- assemblies installed in areas accessible to unskilled persons, and for short-circuit current equal or greater than 16 kA with non-instantaneous tripping.

The 7 evaluation criteria

IEC/TR 61641 defines 7 evaluation criteria for the internal arc test results (refer to IEC/TR 61641:2014 for more details):

1. Doors and panels remain securely fastened and do not open;
2. No part of the assembly of a mass exceeding 60 g shall be ejected;
3. The arc does not cause holes to develop in the external parts of the envelope below 2 m, at the sides declared to be accessible;
4. The indicators (cotton fabric placed vertically close to the assembly) do not ignite. Indicators ignited as a result of paint or stickers burning are excluded from this assessment;
5. The protective circuit for accessible part of the enclosure is still effective in accordance with IEC 61439-2;
6. The assembly is capable of confining the arc to the defined area where it was initiated, and there is no propagation of the arc to other areas within the assembly;
7. After clearing of the fault or after isolation or disassembly of the affected functional units in the defined area, emergency operation of the remaining assembly is possible.

[1] Low-voltage switchgear and controlgear assemblies - Part 2: Power switchgear and controlgear assemblies

[2] Enclosed low-voltage switchgear and controlgear assemblies - Guide for testing under conditions of arcing due to internal fault

2 The installation system

Classification (arcing class)

Based on the results of the tests on the 7 evaluation criteria, the following classification is defined:

Classification item	Classifications	Comments
Assembly which is tested according to IEC/TR 61641	Arcing Class A: personnel protection. (Criteria 1 to 5)	
	Arcing Class B: personnel protection plus arcing restricted to a defined area within the assembly. (Criteria 1 to 6)	Where there is an agreement between the user and the manufacturer, less or different criteria may apply
	Arcing Class C: personnel protection plus arcing restricted to a defined area within the assembly. Limited operation after the fault is possible. (Criteria 1 to 7)	
	Arcing Class I: Assembly providing protection by means of arc ignition protected zones.	
Access	Restricted (default)	Authorized persons only have access to the assembly.
	Unrestricted	The assembly can be placed in a location accessible to everyone including ordinary persons

Fig. E37 Classification of assemblies according to internal arc tests (Table A.1 of IEC/TR 60641:2014)

E23

Class I is a totally different approach compared to other classes.

Class I: Arc ignition protected zones

In the unlikely case of an arc appearing in an assembly, classes A, B and C focus on the consequences of the effects of the arc, whilst Class I adopts the philosophy of "prevention is better than cure".

Class I seeks to reduce dramatically the risk of occurrence of an arc fault by insulating each conductor individually, as much as possible, with solid-insulation.

Class I may be limited to specific zones of an assembly, as declared by the manufacturer, for example a functional unit or the busbar compartment(s). These zones offering protection in accordance with the Class I are called **arc ignition protected zones**. The insulation shall provide protection against direct contact in accordance with IP 4X as per IEC 60529 [3] and withstand a dielectric test of 1.5 times the normal test value for an assembly.

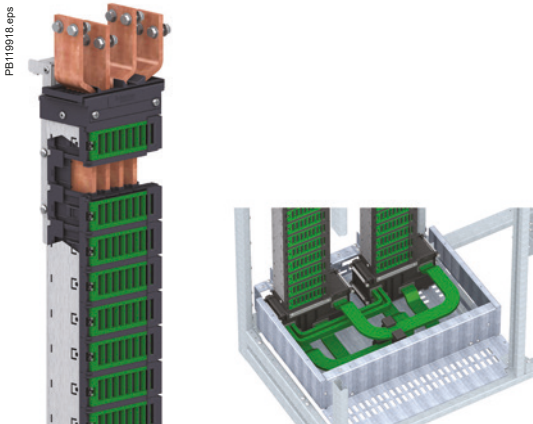


Fig. E38 Example of totally insulated busbar reducing the risk of internal arc-fault ignition (Okken MCC vertical busbar, Schneider Electric)

[3] Degrees of protection provided by enclosures (IP Code)

2 The installation system

The internal arc test

The main objective of an internal arc test is to demonstrate, as much as possible, an improved level of safety for personnel in the proximity of an assembly, when an internal arc-fault occurs.

During the test, personnel clothing is simulated by "indicators" around the assembly. The indicators are composed of different shades of cotton to simulate standard clothing or light work clothing (i.e. to represent assembly installation in non-restricted or restricted access zones).

PB119917.eps

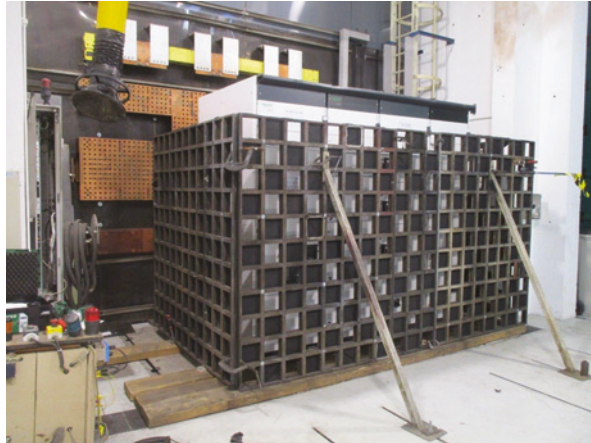


Fig. E39 Example of assembly prepared for internal arc test, with "indicators" visible on the front and side (Okken, Schneider Electric)

Another rationale to perform internal arc tests on an assembly is to demonstrate the impact of the fault on the assembly itself. In certain cases, and as defined by the Arcing class, it is worth limiting the arc damage to a part of the assembly, so that the rest of the assembly (or part of it) could be re-powered for a limited use after a few maintenance.

Arc-fault detection and mitigation

Another approach to internal arc-fault management exists:

- some relays can detect an arc-fault in an assembly, usually by sensing the light of the arc-fault, possibly in combination with current measurement. Such relays can even detect the fault in a few milliseconds
- When an arc fault is detected, this relay can trigger the "instantaneous" trip of an upstream circuit-breaker. This permit to limit dramatically the energy released by the arc-fault. See **Fig. E40** below as an example.
- In addition, the operation of an internal arc quenching device can be activated, achieving ultimate performance in reducing arc-fault duration (less than 5ms).

This topic is currently evolving in standardization committees, both for product and equipment standards.

PB119920.eps

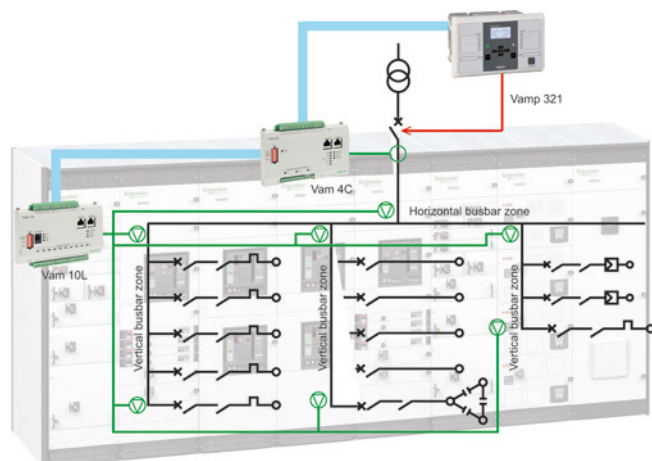


Fig. E40 Example of arc-fault mitigation system (Okken + Vamp system)

2 The installation system

Two types of distribution are possible:

- By insulated wires and cables
- By busbar trunking (busways)

2.2 Cables and busways

Distribution by insulated conductors and cables

Definitions

- Conductor



A conductor comprises a single metallic core with or without an insulating envelope.

- Cable



A cable is made up of a number of conductors, electrically separated, but joined mechanically, generally enclosed in a protective flexible sheath.

- Cableway



The term cableway refers to conductors and/or cables together with the means of support and protection, etc. for example : cable trays, ladders, ducts, trenches, and so on... are all "cableways".

Conductor marking

Conductor identification must always respect the following three rules:

- Rule 1

The double colour green and yellow is strictly reserved for the PE and PEN protection conductors

- Rule 2

When a circuit comprises a neutral conductor, it must be light blue or marked "1" for cables with more than five conductors

When a circuit does not have a neutral conductor, the light blue conductor may be used as a phase conductor if it is part of a cable with more than one conductor

- Rule 3

Phase conductors may be any colour except:

Green and yellow

Green

Yellow

Light blue (see rule 2).

Conductors in a cable are identified either by their colour or by numbers (see **Fig. E41**).

2 The installation system

E26

Number of conductors in circuit	Circuit	Fixed cableways									
		Insulated conductors					Rigid and flexible multi conductor cables				
		Ph	Ph	Pn	N	PE	Ph	Ph	Ph	N	PE
1	Protection or earth					G/Y					
2	Single-phase between phases	■	■				BL	LB			
	Single-phase between phase and neutral	■			LB		BL			LB	
	Single-phase between phase and neutral + protection conductor	■			G/Y		BL			G/Y	
3	Three-phase without neutral	■	■	■			BL	B	LB		
	2 phases + neutral	■	■		LB		BL	B		LB	
	2 phases + protection conductor	■	■			G/Y	BL	LB			G/Y
	Single-phase between phase and neutral + protection conductor	■			LB	G/Y	BL			LB	G/Y
4	Three-phase with neutral	■	■	■	LB		BL	B	BL	LB	
	Three-phase with neutral + protection conductor	■	■	■		G/Y	BL	B	LB		G/Y
	2 phases + neutral + protection conductor	■	■		LB	G/Y	BL	B		LB	G/Y
	Three-phase with PEN conductor	■	■	■	G/Y		BL	B	LB	G/Y	
5	Three-phase + neutral + protection conductor	■	■	■	LB	G/Y	BL	B	BL	LB	G/Y
> 5		Protection conductor: G/Y - Other conductors: BL: with numbering The number "1" is reserved for the neutral conductor if it exists									

G/Y: Green and yellow BL: Black ■: As indicated in rule 3 LB: Light blue B: Brown

Fig. E41 Conductor identification according to the type of circuit

DB422184_EN.eps

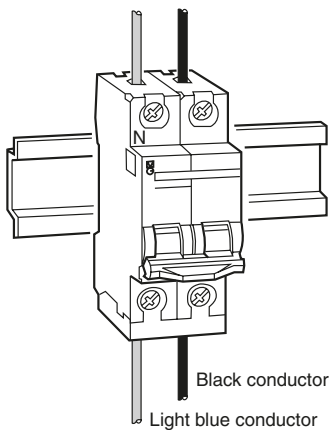


Fig. E42 Conductor identification on a circuit breaker with a phase and a neutral

DB422185_EN.eps

Note: If the circuit includes a protection conductor and if the available cable does not have a green and yellow conductor, the protection conductor may be:

- A separate green and yellow conductor
- The blue conductor if the circuit does not have a neutral conductor
- A black conductor if the circuit has a neutral conductor.

In the last two cases, the conductor used must be marked by green and yellow bands or markings at the ends and on all visible lengths of the conductor.

Equipment power cords are marked similar to multi-conductor cables (see Fig. E42).

Distribution and installation methods (see Fig. E43)

Distribution takes place via cableways that carry single insulated conductors or cables and include a fixing system and mechanical protection.

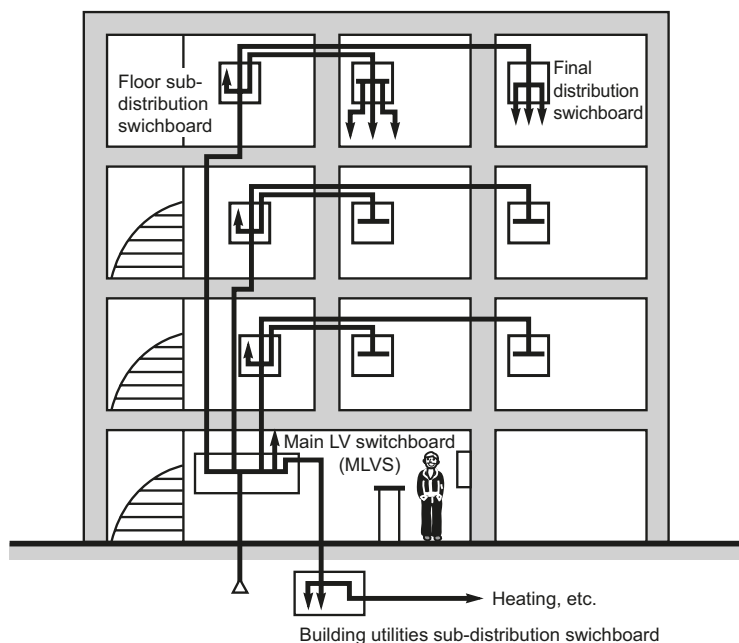


Fig. E43 Radial distribution using cables in a hotel

2 The installation system

Busways, also referred to as busbar trunking systems, stand out for their ease of installation, flexibility and number of possible connection points

Busbar trunking (busways)

Busbar trunking is intended to distribute power (from 20 A to 5000 A) and lighting (in this application, the busbar trunking may play a dual role of supplying electrical power and physically holding the lights).

Busbar trunking system components

A **busbar trunking** system comprises a set of conductors protected by an enclosure (see Fig. E44). Used for the transmission and distribution of electrical power, busbar trunking systems have all the necessary features for fitting: connectors, straights, angles, fixings, etc. The tap-off points placed at regular intervals make power available at every point in the installation.

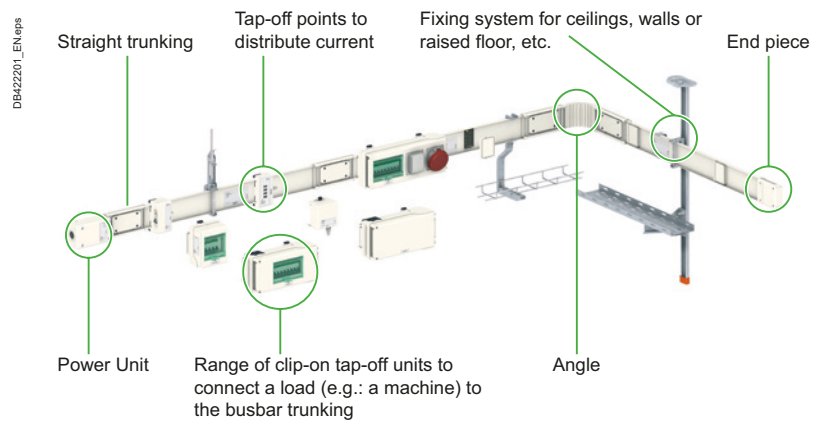


Fig. E44 Busbar trunking system design for distribution of currents from 25 to 4000 A

E27

The various types of busbar trunking:

Busbar trunking systems are present at every level in electrical distribution: from the link between the transformer and the low voltage switch switchboard (MLVS) to the distribution of power sockets and lighting to offices, or power distribution to workshops.

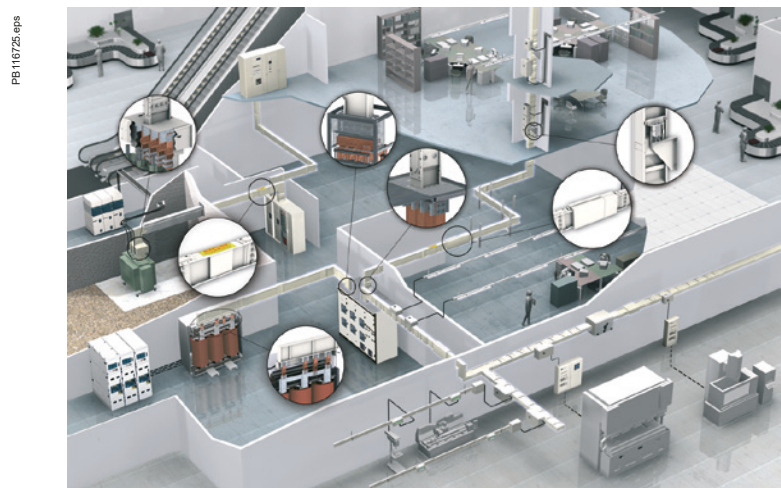


Fig. E45 Radial distribution using busways

We talk about a distributed network architecture.

2 The installation system

There are essentially three categories of busways.

■ Transformer to MLVS busbar trunking

Installation of the busway may be considered as permanent and will most likely never be modified. There are no tap-off points.

Frequently used for short runs, it is almost always used for ratings above 1600 / 2000 A, i.e. when the use of parallel cables makes installation impossible. Busways are also used between the MLVS and downstream distribution switchboards.

The characteristics of main-distribution busways authorize operational currents from

1000 to 5000 A and short-circuit withstands up to 150 kA.

■ Sub-distribution busbar trunking with low or high tap-off densities

Downstream of main-distribution busbar trunking, two types of applications must be supplied:

□ Mid-sized premises (industrial workshops with injection presses and metalwork machines or large supermarkets with heavy loads). The short-circuit and current levels can be fairly high (respectively 20 to 70 kA and 100 to 1000 A)

□ Small sites (workshops with machine-tools, textile factories with small machines, supermarkets with small loads). The short-circuit and current levels are lower (respectively 10 to 40 kA and 40 to 400 A)

Sub-distribution using busbar trunking meets user needs in terms of:

□ Modifications and upgrades given the high number of tap-off points

□ Dependability and continuity of service because tap-off units can be connected under energized conditions in complete safety.

The sub-distribution concept is also valid for vertical distribution in the form of 100 to 5000 A risers in tall buildings.

■ Lighting distribution busbar trunking

Lighting circuits can be distributed using two types of busbar trunking according to whether the lighting fixtures are suspended from the busbar trunking or not.

□ busbar trunking designed for the suspension of lighting fixtures

These busways supply and support light fixtures (industrial reflectors, discharge lamps, etc.). They are used in industrial buildings, supermarkets, department stores

and warehouses. The busbar trunkings are very rigid and are designed for one or two 25 A or 40 A circuits. They have tap-off outlets every 0.5 to 1 m.

□ busbar trunking not designed for the suspension of lighting fixtures

Similar to prefabricated cable systems, these busways are used to supply all types of lighting fixtures secured to the building structure. They are used in commercial buildings (offices, shops, restaurants, hotels, etc.), especially in false ceilings. The busbar trunking is flexible and designed for one 20 A circuit. It has tap-off outlets every 1.2 m to 3 m.

Busbar trunking systems are suited to the requirements of a large number of buildings.

■ Industrial buildings: garages, workshops, farm buildings, logistic centers, etc.

■ Commercial areas: stores, shopping malls, supermarkets, hotels, etc.

■ Tertiary buildings: offices, schools, hospitals, sports rooms, cruise liners, etc.

Standards

Busbar trunking systems must meet all rules stated in IEC 61439-6.

This defines the manufacturing arrangements to be complied with in the design of busbar trunking systems (e.g.: temperature rise characteristics, short-circuit withstand, mechanical strength, etc.) as well as test methods to check them.

The standard IEC61439-6 describes in particular the design verifications and routine verifications required to ensure compliance.

By assembling the system components on the site according to the assembly instructions, the contractor benefits from conformity with the standard.

The advantages of busbar trunking systems

Flexibility

■ Easy to change configuration (on-site modification to change production line configuration or extend production areas).

■ Reusing components (components are kept intact): when an installation is subject to major modifications, the busbar trunking is easy to dismantle and reuse.

■ Power availability throughout the installation (possibility of having a tap-off point every meter).

■ Wide choice of tap-off units.

2 The installation system

Simplicity

- Design can be carried out independently from the distribution and layout of current consumers.
- Performances are independent of implementation: the use of cables requires a lot of derating coefficients.
- Clear distribution layout
- Reduction of fitting time: the trunking system allows fitting times to be reduced by up to 50 % compared with a traditional cable installation.
- Manufacturer's guarantee.
- Controlled execution times: the trunking system concept guarantees that there are no unexpected surprises when fitting. The fitting time is clearly known in advance and a quick solution can be provided to any problems on site with this adaptable and scalable equipment.
- Easy to implement: modular components that are easy to handle, simple and quick to connect.

Dependability

- Reliability guaranteed by being factory-built
- Fool-proof units
- Sequential assembly of straight components and tap-off units making it impossible to make any mistakes

Continuity of service

- The large number of tap-off points makes it easy to supply power to any new current consumer. Connecting and disconnecting is quick and can be carried out in complete safety even when energized. These two operations (adding or modifying) take place without having to stop operations.
- Quick and easy fault location since current consumers are near to the line
- Maintenance is non-existent or greatly reduced.

Major contribution to sustainable development

- Busbar trunking systems allow circuits to be combined. Compared with a traditional cable distribution system, consumption of raw materials for insulators is divided by 4 due to the busbar trunking distributed network concept (see Fig. E46).
- Reusable device and all of its components are fully recyclable.
- Does not contain PVC and does not generate toxic gases or waste.
- Reduction of risks due to exposure to electromagnetic fields.

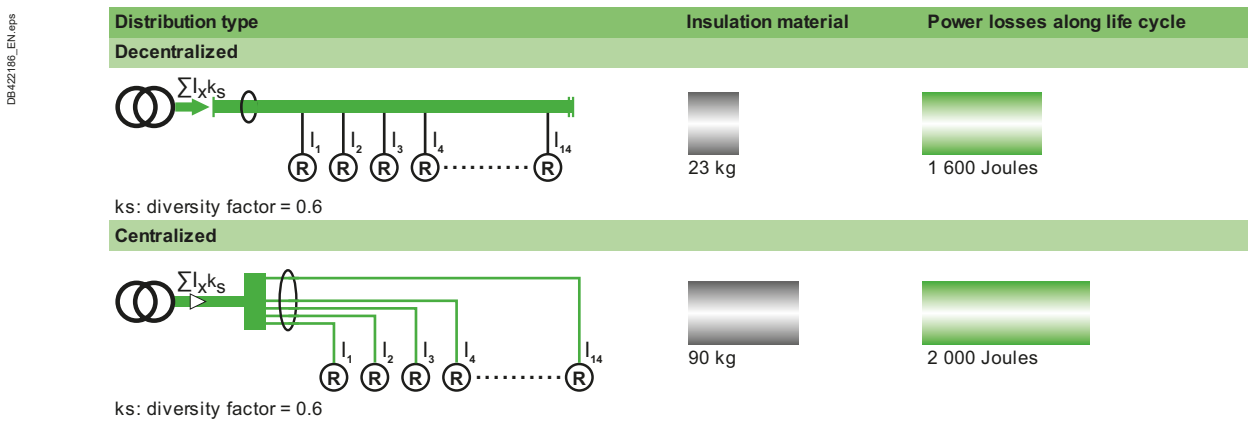


Fig. E46 Example of a set of 14 x 25A loads distributed along 34 meters (for busway, Canalis KS 250A)

Functional features for Canalis

Busbar trunking systems are getting even better. Among the features we can mention:

- Increased performance with a IP55 protection index and ratings of 160 A through to 1000 A (Ks).
- Lighting offers with pre-cabled lights and light ducts.
- Fixing accessories. Quick fixing system, cable ducts, shared support with "VDI" (voice, data, images) circuits.

2 The installation system

Busbar trunking systems are perfectly integrated with the environment:

- white color to enhance the working environment, naturally integrated in a range of electrical distribution products.
- conformity with European regulations on reducing hazardous materials (RoHS).

Examples of Canalis busbar trunking systems

PB116726.eps



Fig. E47 Rigid busbar trunking able to support light fittings: Canalis KBA or KBB (25 and 40 A)

PB116727.eps

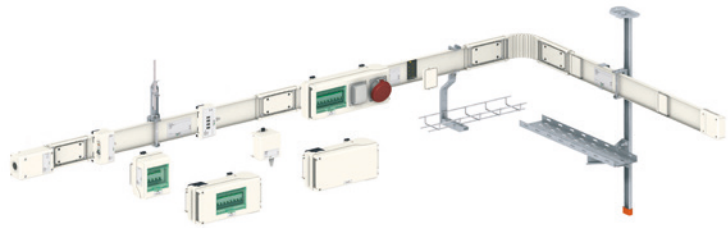


Fig. E48 A busway for medium power distribution: Canalis KN (40 up to 160 A)

PB116728.eps

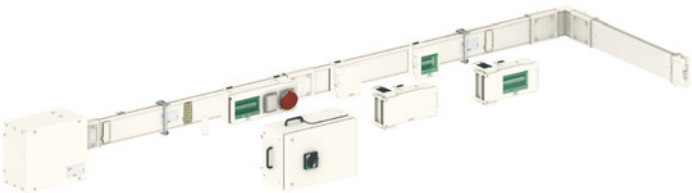


Fig. E49 A busway for medium power distribution: Canalis KS (100 up to 1000 A)

PB116729.eps

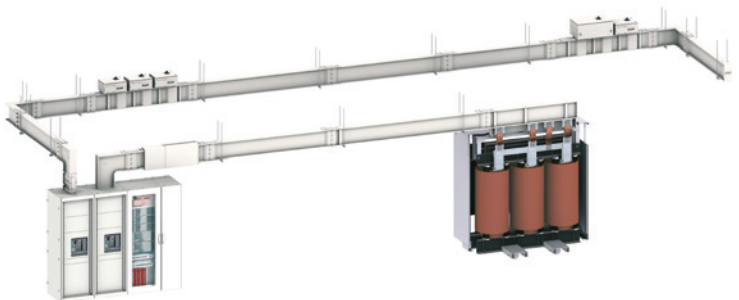


Fig. E50 A busway for high power distribution: Canalis KT (800 up to 5000 A)

2.3 Harmonic currents in the selection of busbar trunking systems (busways)

2.3.1 Introduction

Harmonic current is generated by most modern electronic loads, which can be found in all sectors of Industrial, Commercial, and domestic facilities. These electronic loads use power electronic devices which are responsible for generating harmonic currents. Common non-linear loads:

- Industrial equipment (Soldering machines, Induction furnaces, bridge rectifiers and battery chargers)
- Variable Speed Drives (VSDs) with AC or DC motors
- Uninterruptible Power Supplies (UPS)
- Information Technology Equipment (computers, monitors, servers, copiers, printers, etc.)
- Domestic equipment (TV sets, microwave ovens, fluorescent lamps, light dimmers, etc.).

E31

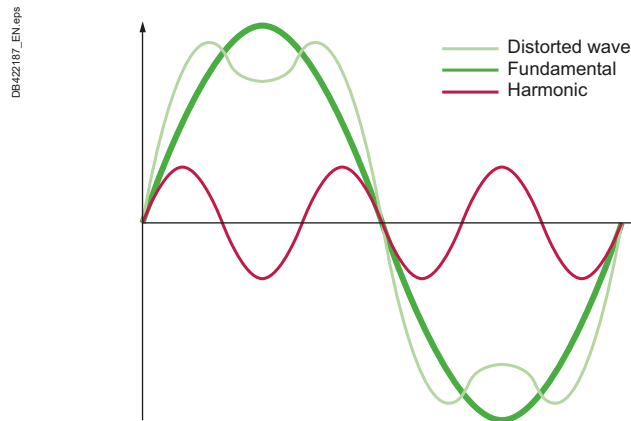


Fig. E51 Appearance of a distorted current waveform due to harmonics

Today's electronic loads share a common element: electronic power supplies. The benefits of the electronic power supply are its cost, efficiency and the ability to control its output. For this reason, they are found in a wide variety of common single and three-phase electrical equipment. Harmonic currents are a natural by-product of the manner in which electronic power supplies draw current. In order to be more efficient, these devices draw current for only a small portion of the electrical cycle.

Installations where these devices can be found in great number are computer centers, banks, Internet Data Centers etc.

Harmonic currents generated by these loads present some problems:

- Voltage distortion responsible for failure of some types of electrical equipment
- Increased losses, the rms current being higher than the fundamental design current
- Risk of resonance when power factor correction capacitors are present.

Third harmonic currents (150/180 Hz) or multiple of 3 (triple-n harmonics) are specifically responsible for increased neutral currents in three-phase, four-wire systems.

That the reason why it's important to select optimum busbar design for office buildings, where neutral conductor overload is a major concern.

2 The installation system

E32

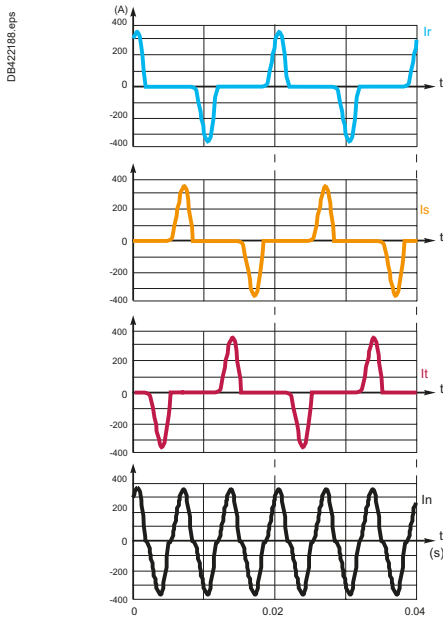
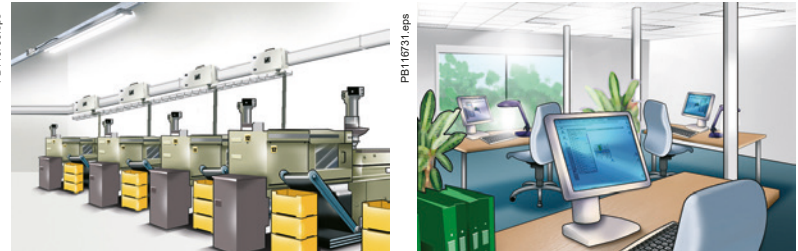


Fig. E52 Line and neutral currents absorbed by single-phase non-linear loads connected between phase and neutral.

2.3.2 Neutral current in three-phase, four-wire systems

Fig. E52 represents the non-linear phase currents and resulting non-linear neutral current, in a three-phase, four-wire system, supplying identical single phase loads.



Workshops supply:

- Mix polluting charges and clean charges (computer hardware, inverters, fluorescent lighting and motors, pumps, heaters, etc.).
- Little probability of harmonic's presence
- THD < 33 %**

Offices supply:

- A lot of polluting charges (computer hardware, inverters, fluorescent lighting, etc.).
- Strong probability of harmonic's presence
- THD ≥ 33 %**

Fig. E53 Examples of applications where the level of harmonics (THD) is either negligible or high, depending on the proportion of loads generating harmonics versus classical loads

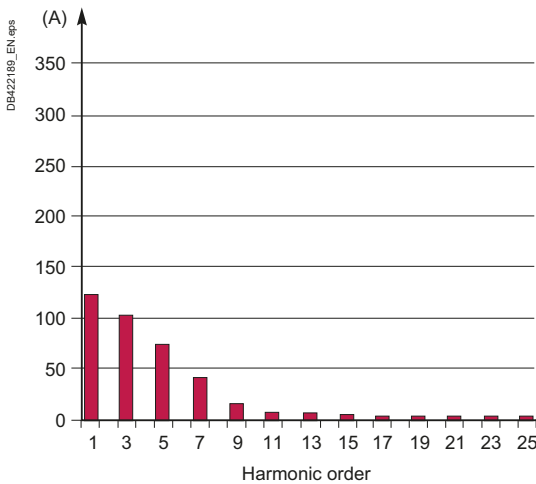


Fig. E54 Typical harmonic phase current spectrum for single-phase non-linear loads

The harmonic spectra of the phase and neutral currents are represented in **Fig. E54** and **Fig. E55**. It can be seen that the neutral current only includes third or triple-n harmonics (i.e. 3, 9, 15, etc). The amplitude of these currents are equal to three times the amplitude of the phase currents. In the neutral current measurements, third harmonic has the greatest magnitude and the other triple-n's (9, 15, 21, etc.) decrease significantly in magnitude so do not contribute significantly to the rms value.

In this example, the rms value of the neutral current is equal to 1.732 ($\sqrt{3}$) times the rms value of the line current. This theoretical value is only obtained with loads absorbing a current similar to the one represented on **Fig. E52**.

When the loads include partially linear circuits (such as motors, heating devices, incandescent lamps), the rms value of the neutral current is strictly less than $\sqrt{3}$ times the rms value of the phase currents.

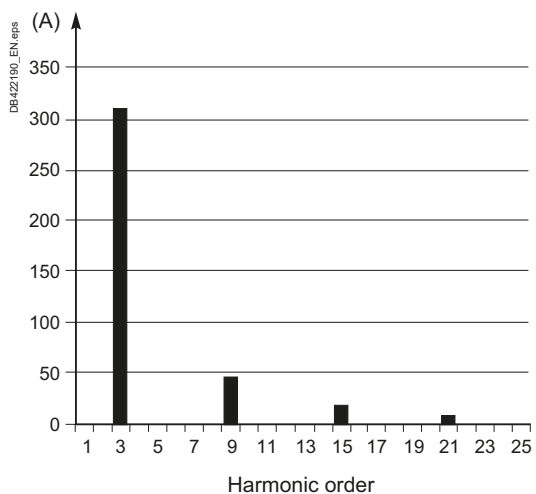


Fig. E55 Typical harmonic neutral current spectrum for single-phase non-linear loads

2 The installation system

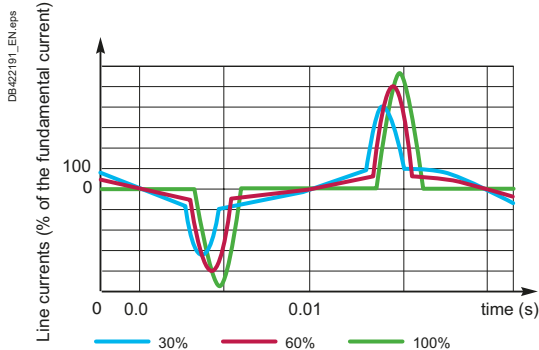


Fig. E56 Line current for different ratios of non-linear load

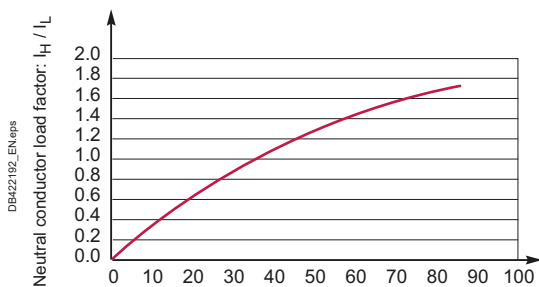


Fig. E57 Neutral conductor load factor as a function of the 3rd harmonic level.

2.3.3 Load factor of the neutral conductor

Simulations have been carried out to assess the influence of the 3rd harmonic level on the neutral conductor current. Fig. E56 represents different line current waveforms for different amounts of non-linear load. The same active power was maintained (linear loads are assumed purely resistive).

The neutral current is then calculated and compared to the line current for different levels of third harmonic. The load factor of the neutral conductor (ratio of the neutral current to the line current) is represented in Fig. E57.

In installations where there are a large number of single-phase electronic non-linear loads connected to the same neutral, a high load factor can be found in that neutral.

In these installations the neutral current may exceed the phase current and a special attention must be given to sizing the neutral conductor. This prevents the installation of a reduced size neutral conductor, and the current in all four wires should be taken into account.

The diversified power absorbed by such a group of loads is generally limited, and even if the neutral current exceeds the line current, then the neutral conductor capacity is only exceeded in extreme circumstances if its size is equal to the line conductor's.

A common practice in these conditions is to use a 200 % neutral conductor. This does not form part of the electrical/ building regulations, but is encouraged by organizations such as the Copper Development Association.

In high power installations (>100 kVA or >150 A), various factors contribute to reduce the neutral conductor load factor:

- More and more high quality IT equipment (work stations, servers, routers, PC, UPS, etc.) include Power Factor Correction circuits, reducing considerably the generation of 3rd harmonic currents

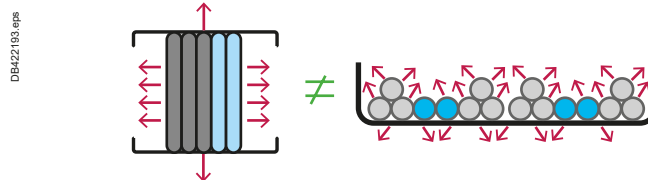


Fig. E58 Double-neutral installation for cable solution is not directly applicable for busway solution, due to their very different thermal dissipation behaviour.

- HVAC equipment in large buildings are supplied by a three-phase network, and as such do not produce triple-n harmonic currents
- Fluorescent lighting equipment (with magnetic or electronic ballast) generates triple-n harmonic currents which are phase shifted with harmonic currents generated by PCs, giving a partial vector cancellation.

Except in exceptional circumstances, the 3rd harmonic level in these installations does not exceed 33 %, so the neutral current does not exceed the line currents. It is not therefore necessary to use an oversized neutral conductor.

2 The installation system

E34

2.3.4 Effects of harmonic currents on circuit conductors

The circulation of harmonic currents produces additional heating within the conductors for several reasons:

- Heat is produced as a result of the additional high levels of triple-n harmonic currents, compared with the relatively minimal current flowing in the neutral for normal balanced linear loads.
- Additional heating of all conductors by increase of the skin effect and eddy current losses due to the circulation of all harmonic orders.

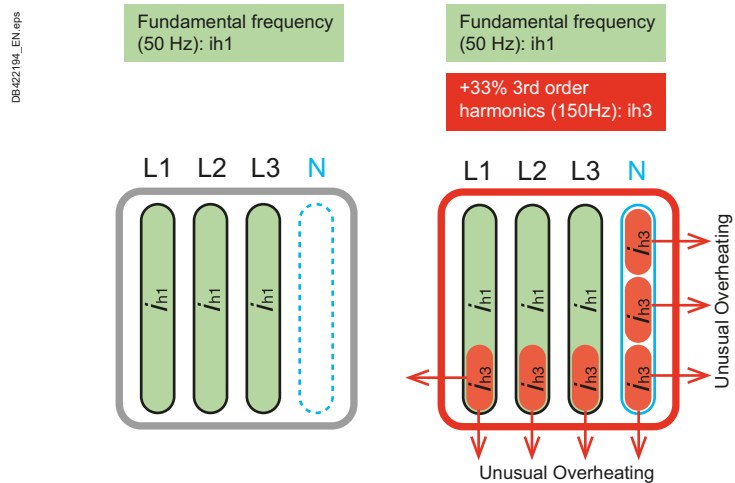


Fig. E59 Illustration of the overheating risk with standard busway sizing in presence of high level of 3rd harmonics

Modeling separately the power losses created by each harmonic order reveals the impact of harmonic currents in busbar trunking systems. Heat measurements performed on busbar trunking systems with circulation of harmonic currents of different frequencies has also been considered.

The same approach has been used to compare two different type of busbar construction both with the same total cross sectional area (c.s.a.) of active conductors, a 200 % neutral and a standard 100 % neutral. This can be seen in Fig. E60.

Placed in the same conditions, a busbar trunking system with 4 identical conductors will have a lower temperature rise than a 200 % busbar with the same total c.s.a.

It is then perfectly adapted to this situation. Of course, the selection of the size of the conductors must take the possible current flowing through the neutral conductor into account.

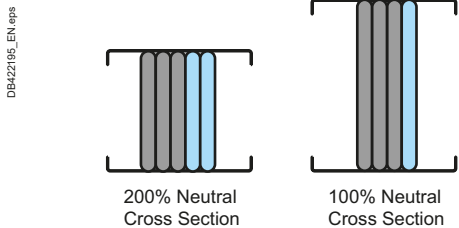


Fig. E60 Cross section architecture of 2 different busbar systems.

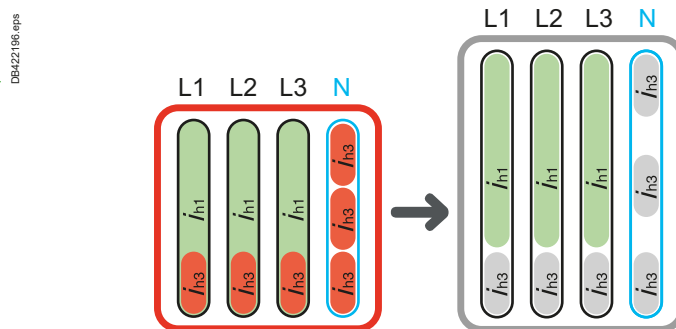


Fig. E61 The most effective solution = reduce the current density in ALL conductors, by selecting proper busway rating (single-neutral)

2.3.5 Simplified selection procedure

The first step in the selection procedure for busbar trunking systems is to assess the phase currents and 3rd harmonic current level.

Note: the 3rd harmonic current level has an impact on the neutral current, and consequently on the rating of all components in the installation:

- Switchboard,

2 The installation system

- Protection and dispatching switchgear,
- Cables and busbar trunking systems.

Depending on the estimated 3rd harmonic level, 3 cases are possible:

A) 3rd harmonic level below 15 % ($i_{h3} \leq 15\%$):

The neutral conductor is considered as not loaded. The size of the phase conductors is only dependant on the phase currents. According to IEC rules, the neutral conductor size may be smaller than the phase conductors', if the cross section area is higher than 16 mm² for copper, or 25 mm² for aluminum.

B) 3rd harmonic level between 15 and 33 % ($15 < i_{h3} \leq 33\%$)

The neutral conductor is considered as current-carrying conductor.

The practical current shall be reduced by a factor equal to 84 % (or inversely, select a busbar with a practical current equal to the phase current divided by 0.84. Generally, this leads to the selection of a busbar trunking system, which the current rating is immediately superior to the requested capacity.

The size of the neutral conductor shall be equal to that of the phases.

C) 3rd harmonic level higher than 33 % ($i_h > 33\%$)

The neutral conductor is considered as a current-carrying conductor.

The recommended approach is to adopt circuit conductors with equal size for phase and neutral. The neutral current is predominant in the selection of the size of conductor.

Generally, this leads to the selection of a busbar trunking system which current rating is higher than the requested capacity (generally by a factor of two).

Example for KT Schneider-Electric offer:

Rating (A)	No harmonic	Usual harmonic level	Very high level
1000	KTC1000	KTC1000HRB	KTC1350HRB
1350	KTC1350	KTC1350HRB	KTC1600HRB
1600	KTC1600	KTC1600HRB	KTC2000HRB
2000	KTC2000	KTC2000HRB	KTC2500HRB
2500	KTC2500	KTC2500HRB	KTC3200HRB
3200	KTC3200	KTC3200HRB	KTC4000HRB
4000	KTC4000	KTC4000HRB	
5000	KTC5000		

E35

DB422197_EN.eps

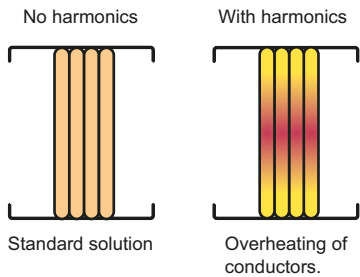


Fig. E62 Cross sectional view of a standard busway without and with harmonics

2.3.6 Conclusions

Office buildings are often subject to the circulation of high levels of triple-n harmonics in particular 3rd harmonic current. These are responsible for possible overload of the neutral conductor.

The performance of standard construction busbar trunking system with circulation of harmonic currents has been analyzed in depth.

A simplified procedure has been proposed for selection of busbar trunking systems adapted to the circulation of harmonic currents, and particularly in the neutral conductor.

A 200 % neutral conductor is not the optimum solution.

Busbar trunking systems with equal size for all conductors are perfectly adapted to harmonic distortion. The design is valid as long as the design for a realistic neutral overload is taken into consideration and is applied to the whole system.

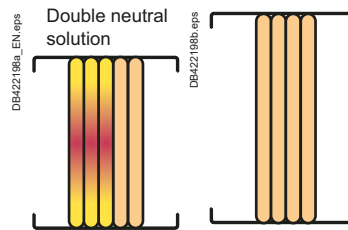
The raw material and performance optimization for more guarantees

Fig. E63 shows the comparison between 2 busway constructions. The test conditions are the same for both cases:

- Phase current: $I_L = 1600\text{ A}$
- 3rd harmonic level: $i_{h3} = 33\%$
- Neutral current: $I_N = 1520\text{ A}$

Placed in the same conditions, a busbar trunking system with 4 identical conductors will have a lower temperature rise than a 200 % busbar with the same total c.s.a.

It is then perfectly adapted to this situation. Of course, the selection of the size of the conductors must take the possible current flowing through the neutral conductor into account.



Temperature rise (°K)	200 % Neutral	100 % Neutral	The double neutral does not deal with all the additional temperature rise
Phase conductor (average)	63.5	41.5	
Neutral conductor	56	39	
Casing (maximum)	55	39	
Conductors c.s.a	200 % Neutral	100 % Neutral	Even though the total cross-section for all conductors is exactly the same for the 2 busways solutions
Phase conductor (average)	960	1200	
Neutral c.s.a. (mm ²)	1920	1200	
Total c.s.a. (mm ²)	4800	4800	

Fig. E63 Comparison between double-neutral busway solution and properly selected single-neutral solution

Coherent system approach

The approach on busway dedicated to harmonics network performance is a solution approach. The busway is optimized but completely in accordance with the electrical devices connected on it:

- Tap-off unit
- Circuit breakers
- Number of cables.

PB116164-30.eps



PB116732.eps



Fig. E64 Coherent system approach for all components of the electrical installation

3 External influences (IEC 60364-5-51)

External influences shall be taken into account when choosing:

- The appropriate measures to ensure the safety of persons (in particular in special locations or electrical installations)
- The characteristics of electrical equipment, such as degree of protection (IP), mechanical withstand (IK), etc.

If several external influences appear at the same time, they can have independent or mutual effects and the degree of protection must be chosen accordingly

3.1 Definition and reference standards

Every electrical installation occupies an environment that presents a variable degree of risk:

- For people
- For the equipment constituting the installation.

Consequently, environmental conditions influence the definition and choice of appropriate installation equipment and the choice of protective measures for the safety of persons.

The environmental conditions are referred to collectively as “external influences”. Many national standards concerned with external influences include a classification scheme which is based on, or which closely resembles, that of international standard IEC 60364-5-51.

3.2 Classification

Each condition of external influence is designated by a code comprising a group of two capital letters and a number as follows:

First letter (A, B or C)

The first letter relates to the general category of external influence:

- A = environment
- B = utilisation
- C = construction of buildings.

Second letter

The second letter relates to the nature of the external influence.

Number

The number relates to the class within each external influence.

Additional letter (optional)

Used only if the effective protection of persons is greater than that indicated by the first IP digit.

When only the protection of persons is to be specified, the two digits of the IP code are replaced by the X's.

Example: IP XXB.

Example

For example the code AC2 signifies:

- A = environment
- AC = environment-altitude
- AC2 = environment-altitude > 2000 m.

3.3 List of external influences

Fig. E65 below is from IEC 60364-5-51, which should be referred to if further details are required.

Code	External influences				Characteristics required for equipment	
A - Environment						
AA						
	Ambient temperature (°C)					
	Low	High			Specially designed equipment or appropriate arrangements	
AA1	-60 °C	+5 °C				
AA2	-40 °C	+5 °C				
AA3	-25 °C	+5 °C				
AA4	-5 °C	+40 °C				Normal (special precautions in certain cases)
AA5	+5 °C	+40 °C				Normal
AA6	+5 °C	+60 °C				Specially designed equipment or appropriate arrangements
AA7	-25 °C	+55 °C				
AA8	-50 °C	+40 °C				

Fig. E65 List of external influences (taken from Appendix A of IEC 60364-5-51)

3 External influences (IEC 60364-5-51)

Code	External influences						Characteristics required for equipment
AB	Atmospheric humidity						
	Air temperature °C		Relative humidity %		Absolute humidity g/m ³		
	Low	High	Low	High	Low	High	
AB1	-60 °C	+5 °C	3	100	0.003	7	Appropriate arrangements shall be made
AB2	-40 °C	+5 °C	10	100	0.1	7	
AB3	-25 °C	+5 °C	10	100	0.5	7	
AB4	-5 °C	+40 °C	5	95	1	29	
AB5	+5 °C	+40 °C	5	85	1	25	Normal
AB6	+5 °C	+60 °C	10	100	1	35	Appropriate arrangements shall be made
AB7	-25 °C	+55 °C	10	100	0.5	29	
AB8	-50 °C	+40 °C	15	100	0.04	36	
AC	Altitude						
AC1	≤ 2000 m						Normal
AC2	> 2000 m						May necessitate precaution (derating factors)
AD	Presence of water						
AD1	Negligible		Probability of presence of water is negligible			IPX0	
AD2	Free-falling drops		Probability of presence of water is negligible			IPX1 or IPX2	
AD3	Sprays		Possibility of water falling as a spray at an angle up to 60° from the vertical			IPX3	
AD4	Splashes		Possibility of splashes from any direction			IPX4	
AD5	Jets		Possibility of jets of water from any direction			IPX5	
AD6	Waves		Possibility of water waves (seashore locations)			IPX6	
AD7	Immersion		Possibility of intermittent partial or total covering by water			IPX7	
AD8	Submersion		Equipment is permanently and totally covered			IPX8	
AE	Presence of foreign solid bodies or dust						
			Smallest dimension	Example			
AE1	Negligible					IP0X	
AE2	Small objects		2.5 mm	Tools		IP3X	
AE3	Very small objects		1 mm	Wire		IP4X	
AE4	Light dust					IP5X if dust penetration is not harmful to functioning	
AE5	Moderate dust					IP6X if dust should not penetrate	
AE6	Heavy dust					IP6X	
AF	Presence of corrosive or polluting substances						
AF1	Negligible					Normal	
AF2	Atmospheric					According to the nature of the substance	
AF3	Intermittent, accidental					Protection against corrosion	
AF4	Continuous					Equipment specially designed	
AG	Mechanical shock						
AG1	Low severity					Normal, e.g. household and similar equipment	
AG2	Medium severity					Standard industrial equipment, where applicable, or reinforced protection	
AG3	High severity					Reinforced protection	
AH	Vibrations						
AH1	Low severity		Household or similar			Normal	
AH2	Medium severity		Usual industrial conditions			Specially designed equipment or special arrangements	
AH3	High severity		Severe industrial conditions				
AK	Presence of flora and/or moulds growth						
AK1	No hazard					Normal	
AK2	Hazard					Special protection	
AL	Presence of fauna						
AL1	No hazard					Normal	
AL2	Hazard					Special protection	
AM	Electromagnetic, electrostatic or ionising influences / Low frequency electromagnetic phenomena / Harmonics						
AM1	Harmonics, interharmonics					Refer to applicable IEC standards	
AM2	Signalling voltage						
AM3	Voltage amplitude variations						
AM4	Voltage unbalance						
AM5	Power frequency variations						
AM6	Induced low-frequency voltages						
AM7	Direct current in a.c. network						
AM8	Radiated magnetic fields						
AM9	Electric field						
AM21	Induced oscillatory voltages or currents						

Fig. E65 List of external influences (taken from Appendix A of IEC 60364-5-51)

3 External influences (IEC 60364-5-51)

Code	External influences	Characteristics required for equipment
AM22	Conducted unidirectional transients of the nanosecond time scale	Refer to applicable IEC standards
AM23	Conducted unidirectional transients of the microsecond to the millisecond time scale	
AM24	Conducted oscillatory transients	
AM25	Radiated high frequency phenomena	
AM31	Electrostatic discharges	
AM41	Ionisation	
AN	Solar radiation	
AN1	Low	Normal
AN2	Medium	
AN3	High	
AP	Seismic effect	
AP1	Negligible	Normal
AP2	Low severity	
AP3	Medium severity	
AP4	High severity	
AQ	Lightning	
AQ1	Negligible	Normal
AQ2	Indirect exposure	
AQ3	Direct exposure	
AR	Movement of air	
AR1	Low	Normal
AR2	Medium	
AR3	High	
AS	Wind	
AS1	Low	Normal
AS2	Medium	
AS3	High	
B - Utilization		
BA	Capability of persons	
BA1	Ordinary	Normal
BA2	Children	
BA3	Handicapped	
BA4	Instructed	
BA5	Skilled	
BB	Electrical resistance of human body (under consideration)	
BC	Contact of persons with earth potential	
BC1	None	Class of equipment according to IEC61140
BC2	Low	
BC3	Frequent	
BC4	Continuous	
BD	Condition of evacuation in case of emergency	
BD1	Low density / easy exit	Normal
BD2	Low density / difficult exit	
BD3	High density / easy exit	
BD4	High density / difficult exit	
BE	Nature of processed or stored materials	
BE1	No significant risks	Normal
BE2	Fire risks	Special protection
BE3	Explosion risks	
BE4	Contamination risks	
C - Construction of building		
CA	Construction materials	
CA1	Non combustible	Normal
CA2	Combustible	
CB	Building design	
CB1	Negligible risks	Normal
CB2	Propagation of fire	
CB3	Movement	
CB4	Lexible or unstable	

Fig. E65 List of external influences (taken from Appendix A of IEC 60364-5-51)

3 External influences (IEC 60364-5-51)

3.4 Protection provided for enclosed equipment: codes IP and IK

IP code definition (see Fig. E66)

The degree of protection provided by an enclosure is indicated in the IP code, recommended in IEC 60529.

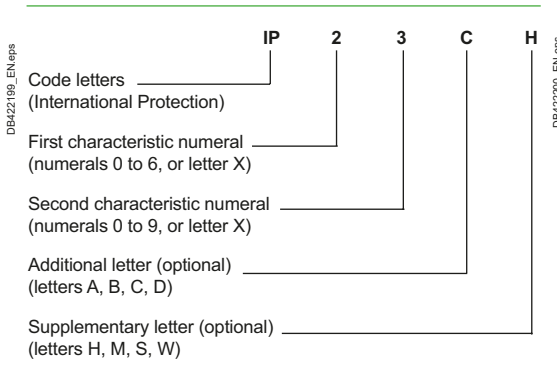
Protection is afforded against the following external influences:

- Penetration by solid bodies
- Protection of persons against access to live parts
- Protection against the ingress of dust
- Protection against the ingress of liquids.

Note: the IP code applies to electrical equipment for voltages up to and including 72.5 kV.

Elements of the IP Code and their meanings

A brief description of the IP Code elements is given in the following chart (see Fig. E67).



Where a characteristic numeral is not required to be specified, it shall be replaced by the letter "X" ("XX" if both numerals are omitted). Additional letters and/or supplementary letters may be omitted without replacement.

Fig. E66 IP Code arrangement

Element	Numerals or letters	Meaning for the protection of equipment	Meaning for the protection of persons
Code letters	IP		
First characteristic numeral	0 1 2 3 4 5 6	Against ingress of solid foreign objects (non-protected) 1 ≥ 50 mm diameter 2 ≥ 12.5 mm diameter 3 ≥ 2.5 mm diameter 4 ≥ 1.0 mm diameter 5 Dust-protected 6 Dust-tight	Against access to hazardous parts with (non-protected) Back of hand Finger Tool Wire Wire
Second characteristic numeral	0 1 2 3 4 5 6 7 8 9	Against ingress of water with harmful effects (non-protected) 1 Vertically dripping 2 Dripping (15° tilted) 3 Spraying 4 Splashing 5 Jetting 6 Powerful jetting 7 Temporary immersion 8 Continuous immersion 9 High pressure and temperature water jet	
Additional letter (optional)	A B C D		Against access to hazardous parts with back of hand Finger Tool Wire
Supplementary letter (optional)	H M S W	Supplementary information specific to: H High-voltage apparatus M Motion during water test S Stationary during water test W Weather conditions	

Fig. E67 Elements of the IP Code

3 External influences (IEC 60364-5-51)

IK Code definition

Standard IEC 62262 defines an IK code that characterises the aptitude of equipment to resist mechanical impacts on all sides (see [Fig. E68](#)).

IK code	Impact energy (in Joules)	AG code
00	0	
01	≤ 0.14	
02	≤ 0.20	AG1
03	≤ 0.35	
04	≤ 0.50	
05	≤ 0.70	
06	≤ 1	
07	≤ 2	AG2
08	≤ 5	AG3
09	≤ 10	
10	≤ 20	AG4

Fig. E68 Elements of the IK Code

E41

IP and IK code specifications for distribution switchboards

The degrees of protection IP and IK of an enclosure must be specified as a function of the different external influences defined by standard IEC 60364-5-51, in particular:

- Presence of solid bodies (code AE)
- Presence of water (code AD)
- Mechanical stresses (no code)
- Capability of persons (code BA)
- ...

Prisma switchboards are designed for indoor installation.

Unless the rules, standards and regulations of a specific country stipulate otherwise, Schneider Electric recommends the following IP and IK values (see [Fig. E69](#) and [Fig. E70](#))

IP recommendations

IK code	Impact energy (in Joules)	AG code
Normal without risk of vertically falling water	Technical rooms	30
Normal with risk of vertically falling water	Hallways	31
Very severe with risk of splashing water from all directions	Workshops	54/55

Fig. E69 IP recommendations

IK recommendations

IK codes according to conditions		
No risk of major impact	Technical rooms	07
Significant risk of major impact that could damage devices	Hallways	08 (enclosure with door)
Maximum risk of impact that could damage the enclosure	Workshops	10

Fig. E70 IK recommendations

Protection against electric shocks and electrical fires

1	Protection against electric shock	F2
	1.1 Danger relative to electric shock.....	F2
	1.2 Protection against electric shock.....	F3
2	Types of protection against electric shock	F4
	2.1 Basic protection.....	F4
	2.2 Fault protection.....	F5
3	Additional protection: High sensitivity RCDs	F6
4	Implementation of TT system	F8
	4.1 Principle.....	F8
	4.2 Practical aspects.....	F8
5	Implementation of TN system	F10
	5.1 Principle.....	F10
	5.2 Preliminary conditions.....	F13
	5.3 Earth-fault current calculation.....	F14
	5.4 High fault current-loop impedance.....	F18
6	Implementation of IT system	F19
	6.1 Principle.....	F19
	6.2 Fault protection.....	F19
	6.3 Implementation of protections.....	F24
	6.4 Practical aspects.....	F27
7	Residual Current Devices (RCDs)	F30
	7.1 Description of RCDs.....	F30
	7.2 Form factors of RCDs.....	F31
	7.3 Types of RCDs.....	F33
	7.4 Sensitivity of RCDs to disturbances.....	F36
	7.5 Coordination of residual current protective devices.....	F40
8	Other protective measures	F43
	8.1 Extra Low Voltage (ELV).....	F43
	8.2 The electrical separation of circuits.....	F44
	8.3 Class II equipment.....	F45
	8.4 Out-of-arm's reach or interposition of obstacles.....	F45
9	Protection against electrical fire risks	F47
	9.1 Fires of electrical origin.....	F47
	9.2 Protection against fire due to earth faults.....	F47
	9.3 Protection against arc faults in cables and connections.....	F50
	9.4 Conclusion.....	F56

1 Protection against electric shock

Introduction

Electric shock

An electric shock is the pathophysiological effect of an electric current through the human body.

Its passage affects essentially the muscular, circulatory and respiratory functions and sometimes results in serious burns. The degree of danger for the victim is a function of the magnitude of the current, the parts of the body through which the current passes, and the duration of current flow.

Protection measures are described in sections 1 to 8.

Electrical fires

Electrical fires are caused by overloads, short circuits and earth leakage currents, but also by electric arcs in cables and connections.

Protection measures are described in section 9.

F2

When a current exceeding 30 mA passes near the heart of a human body, the person concerned is in serious danger if the current is not interrupted in a very short time.

The protection of persons against electric shock in LV installations must be provided in conformity with appropriate national standards, statutory regulations, codes of practice, official guides and circulars etc. Relevant IEC standards include: IEC 61140, 60364, IEC 60479, IEC 61008, IEC 61009 and IEC 60947 series.

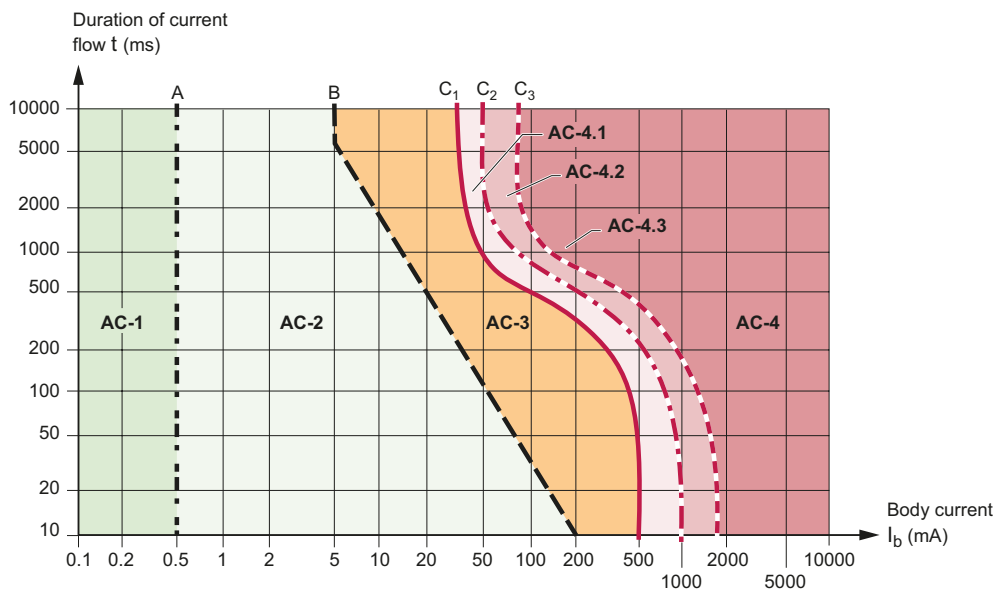
1.1 Danger relative to electric shock

IEC publication 60479-1 updated in 2016 defines four zones of current-magnitude / time-duration, in each of which the pathophysiological effects are described (see Fig. F1).

The protection of persons against electric shock in LV installations must be provided in conformity with appropriate national standards, statutory regulations, codes of practice, official guides and circulars etc.

Relevant IEC standards include: IEC 61140, IEC 60364, IEC 60479, IEC 61008, IEC 61009 and IEC 60947 series.

DE42220_EN eps



AC-1 zone: Imperceptible
 AC-2 zone: Perceptible
 AC-3 zone: Reversible effects: muscular contraction
 AC-4 zone: Possibility of irreversible effects
 AC-4-1 zone: Up to 5 % probability of heart fibrillation
 AC-4-2 zone: Up to 50 % probability of heart fibrillation
 AC-4-3 zone: More than 50 % probability of heart fibrillation

A curve: Threshold of perception of current
 B curve: Threshold of muscular reactions
 C1 curve: Ventricular fibrillation unlikely to happen
 C2 curve: Threshold of 5 % probability of ventricular fibrillation
 C3 curve: Threshold of 50 % probability of ventricular fibrillation

Fig. F1 Zones time/current of effects of AC current on human body when passing from left hand to feet

1 Protection against electric shock

Standards and regulations distinguish two kinds of dangerous contact:

- contact with live parts
- contact with conductive parts in fault conditions

and corresponding protective measures:

- Basic protection
- Fault protection

1.2 Protection against electric shock

The fundamental rule of protection against electric shock is provided by the document IEC 61140 ("Protection against electric shock – Common aspects for installations and equipment") which covers both electrical installations and electrical equipment.

Hazardous-live-parts shall not be accessible, and accessible conductive parts shall not be hazardous.

This requirement needs to apply under:

- Normal conditions, and
- Under a single fault condition.

Various measures are adopted to protect against this hazard, and include:

- Automatic disconnection of the power supply to the connected electrical equipment
- Special arrangements such as:
 - The use of class II insulation materials, or an equivalent level of insulation
 - Non-conducting location, out of arm's reach or interposition of barriers
 - Equipotential bonding
 - Electrical separation by means of isolating transformers.

Contact with live part (Direct contact)

This refers to a person coming into contact with a conductor which is live in normal circumstances (see Fig. F2).

The protection to be implemented in these circumstances is called "**Basic Protection**".

Contact with conductive parts in fault conditions (Indirect contact)

This refers to a person coming into contact with an exposed conductive-part which is not normally live, but has become live accidentally (due to insulation failure or some other cause).

The fault current raises the exposed-conductive-part to a voltage liable to be hazardous as it generates a touch current through a person coming into contact with this exposed-conductive-part (see Fig. F3).

The protection to be implemented in these circumstances is called "**Fault Protection**".

F3

DB42221_EN.eps

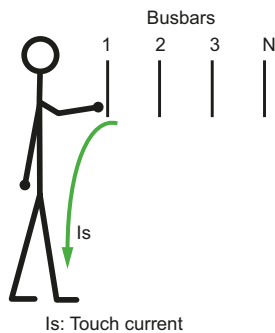


Fig. F2 Contact with live part (Direct contact)

DB42222_EN.eps

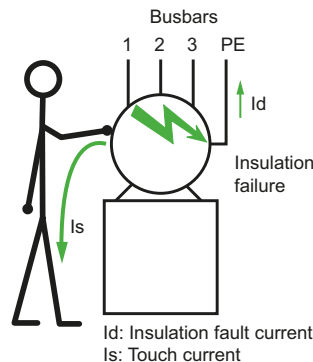


Fig. F3 Contact with parts in fault conditions (Indirect contact)

2 Types of protection against electric shock

F4

The objective is to ensure that **hazardous-live-parts shall not be accessible and accessible conductive parts shall not be hazardous**. Different protective provisions must be implemented. Protective measures result from a suitable combination of them.

Different parameters must be taken into account: ambient temperature, climatic conditions, presence of water, mechanical stresses, capability of persons and area of contact of persons.

2.1 Basic protection

Basic protection includes one or more provisions that, under normal conditions, prevent contact with live parts. Particularly:

Protection by the insulation of live parts

This protection consists of an insulation which complies with the relevant standards (see Fig. F4). Paints, lacquers and varnishes do not provide an adequate protection.

DB42223.eps

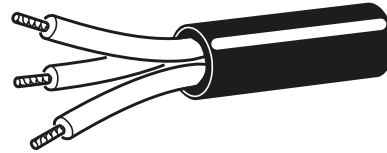


Fig. F4 Inherent protection against direct contact by insulation of a 3-phase cable with outer sheath

PB119913.eps



Fig. F5 Example of isolation by enclosure

Protection by means of barriers or enclosures

This measure is in widespread use, since many components and materials are installed in cabinets, assemblies, control panels and distribution boards (see Fig. F5).

To be considered as providing effective protection against direct contact hazards, these equipment must possess a degree of protection equal to at least IP 2X or IP XXB (see chapter E sub-clause 3.4).

Moreover, an opening in an enclosure (door, front panel, drawer, etc.) must only be removable, open or withdrawn:

- By means of a key or tool provided for this purpose, or
- After complete isolation of the live parts in the enclosure, or
- With the automatic interposition of another screen removable only with a key or a tool. The metal enclosure and all metal removable screen must be bonded to the protective earthing conductor of the installation.

Other measures of protection

■ Protection by means of obstacles, or by placing out of arm's reach.

This protection is reserved to locations to which only skilled or instructed persons have access. The erection of this protective measure is detailed in IEC 60364-4-41. See section 8.4.

■ Protection by use of Extra-Low Voltage (ELV) or by limitation of the energy of discharge. These measures are used only in low-power circuits, and in particular circumstances as described in Section 8.1.

2 Types of protection against electric shock

Fault protection can be achieved by automatic disconnection of the supply if the exposed-conductive-parts of equipment are properly earthed.

2.2 Fault protection

Two levels of protective measures exist:

- The **earthing** of all exposed-conductive-parts of electrical equipment in the installation and the constitution of an equipotential bonding network (see Chapter G, section 6)
- **Automatic disconnection** of the supply of the section of the installation concerned, in such a way that the touch-voltage/time safety requirements are respected for any level of touch voltage U_c ^[1] (see Fig. F6)

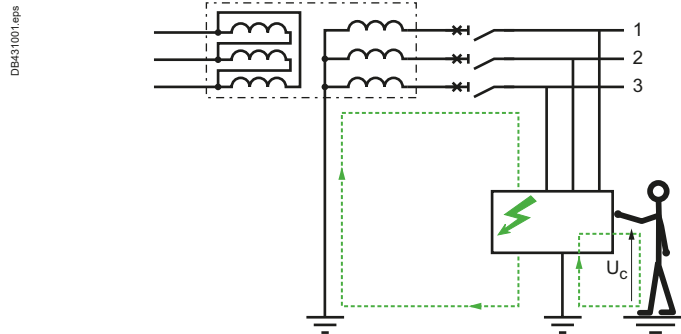


Fig. F6 Illustration of the dangerous touch voltage U_c

The higher the value of U_c , the higher the rapidity of supply disconnection required to provide protection (see Fig. F7). The highest value of U_c that can be tolerated indefinitely without danger to human beings is 50 V AC.

In DC the highest value of U_c that can be tolerated indefinitely without danger is 120 V.

Reminder of the theoretical disconnecting-time limits (IEC 60364-4-41)

U_0 (V AC)	$50 < U_0 \leq 120$	$120 < U_0 \leq 230$	$230 < U_0 \leq 400$	$U_0 > 400$
System TN	0.8	0.4	0.2	0.1
TT	0.3	0.2	0.07	0.04

U_0 is the nominal phase to earth voltage

Fig. F7 Maximum disconnecting times (in seconds) for final circuits not exceeding 63 A with one or more socket-outlets, and 32 A supplying only fixed connected current-using equipment

Nota:

- in **TN systems**, a disconnection time not exceeding 5 s is permitted for distribution circuits, and for circuits not covered by Fig. F7
- in **TT systems**, a disconnection time not exceeding 1 s is permitted for distribution circuits and for circuits not covered by Fig. F7

[1] The touch voltage U_c is the voltage existing (as the result of insulation failure) between an exposed-conductive-part and any conductive element within reach which is at a different (generally earth) potential.

3 Additional protection: High sensitivity RCDs

An additional measure of protection against the hazards of contact with live parts is provided by the use of residual current operating device, which operates at 30 mA or less, and are referred to as High Sensitivity RCDs

All the preceding protective measures are preventive, but experience has shown that for various reasons they cannot be regarded as being infallible. Among these reasons may be cited:

- Lack of proper maintenance
- Imprudence, carelessness
- Normal (or abnormal) wear and tear of insulation; for instance flexure and abrasion of connecting leads
- Accidental contact
- Immersion in water, etc. A situation in which insulation is no longer effective.

In order to protect users in such circumstances, highly sensitive fast tripping devices, based on the detection of residual currents to earth (which may or may not be through a human being or animal) are used to disconnect the power supply automatically, and with sufficient rapidity to prevent injury to, or death by electrocution, of a normally healthy human being (see Fig. F8).

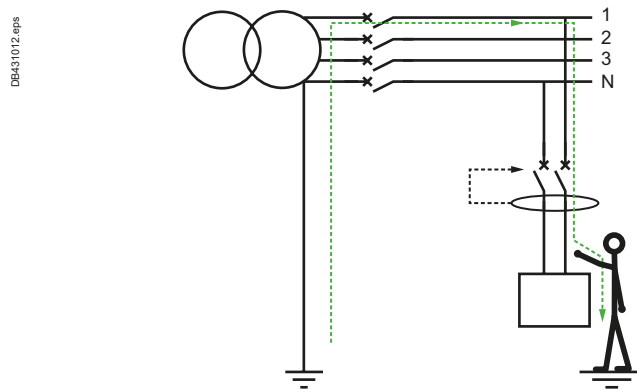


Fig. F8 Additional protection by RCD

These devices operate on the principle of residual current measurement, in which any difference between the current entering a circuit and that leaving it (on a system supplied from an earthed source) is flowing to earth, either through faulty insulation or through contact of an earthed part, such as a person, with a live conductor.

Standardized residual current devices, referred to as RCDs, sufficiently sensitive for protection against contact with live parts are rated at 30 mA of residual current. The response time as defined in IEC 61008 and 61009 is fast enough to provide protection. See Fig. F9.

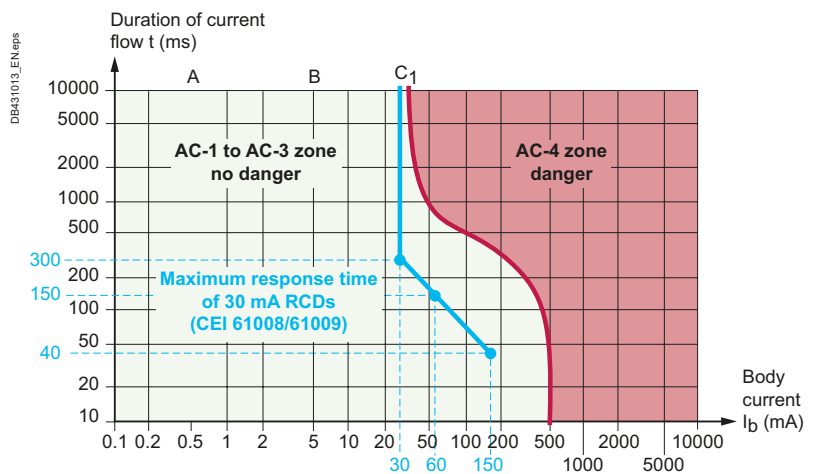


Fig. F9 Tripping curve of High Sensitivity 30mA RCD (in blue) compared to body sensitivity curves

3 Additional protection: High sensitivity RCDs

According to IEC 60364-4-41, additional protection by means of high sensitivity RCDs ($I_{\Delta n} \leq 30 \text{ mA}$) must be provided for:

- circuits supplying general use socket-outlets with a rated current $\leq 32 \text{ A}$ liable to be used by ordinary persons,
- for circuits supplying mobile equipment with a rated current $\leq 32 \text{ A}$ for use outdoors,
- AC final circuits supplying luminaires, in dwelling.

It is also recommended to limit the number of socket-outlets protected by a high sensitivity RCD (e.g. 10 socket-outlets for one RCD).

Chapter Q, clause 3 itemizes various common locations in which RCDs of high sensitivity are mandatory (in some countries), but in any case, are highly recommended as an effective protection against both contact with live parts and contact with conductive parts in fault conditions.

High sensitivity RCDs are suitable for all types of earthing systems.

See **Fig. F10 (a)** for TT or TN systems, and **(b)** for IT system.

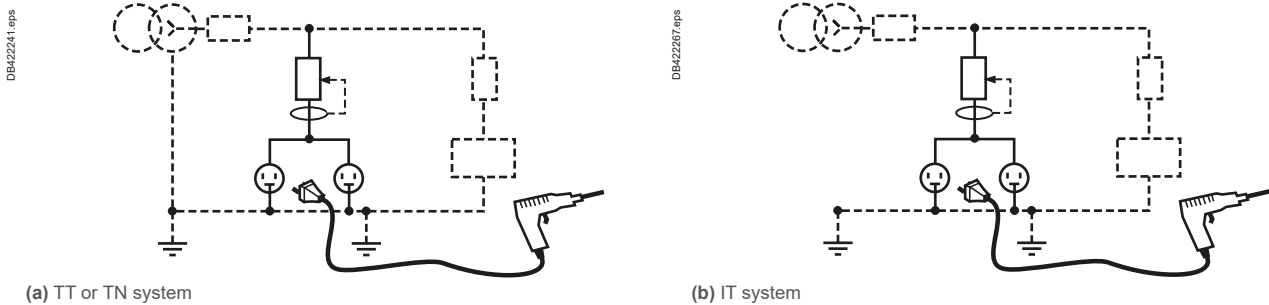


Fig. F10 Circuit supplying socket-outlets

4 Implementation of TT system

Automatic disconnection for TT system is achieved by RCD having a sensitivity of

$$I_{\Delta n} \leq \frac{50}{R_A}$$

where R_A is the resistance of the installation earth electrode

F8

4.1 Principle

In this system, all exposed-conductive-parts and extraneous-conductive-parts of the installation must be connected to a common earth electrode. The neutral point of the supply system is normally earthed at a point outside the influence area of the installation earth electrode, but need not be so. The impedance of the earth fault loop therefore consists mainly in the two earth electrodes (i.e. the source and installation electrodes) in series, so that the magnitude of the earth fault current is generally too small to operate overcurrent relays or fuses, and the use of a residual current operated device is essential.

This principle of protection is also valid if one common earth electrode only is used, notably in the case of a consumer-type substation within the installation area, where space limitation may impose the adoption of a TN system earthing, but where all other conditions required by the TN system cannot be fulfilled.

Protection by automatic disconnection of the supply used in TT system is by RCD of sensitivity:

$$I_{\Delta n} \leq \frac{50}{R_A}$$

Where:

$I_{\Delta n}$ is the rated residual operating current of the RCD

R_A is the resistance of the earth electrode for the installation (maximum value over time)

For temporary supplies (to work sites, ...) and agricultural and horticultural premises, the value of 50 V is replaced by 25 V.

Example (see Fig. F11)

- The resistance of the earth electrode of substation neutral R_n is 10 Ω.
- The resistance of the earth electrode of the installation R_A is 20 Ω.
- The earth-fault loop current $I_d = 7.7$ A.
- The fault voltage $U_f = I_d \times R_A = 154$ V and therefore dangerous, but $I_{\Delta n} \leq 50/20 = 2.5$ A so that a standard 300 mA RCD will operate in about 30 ms without intentional time delay, and will clear the fault where a fault voltage exceeding 50V appears on an exposed-conductive-part.

The choice of sensitivity of the residual current device is a function of the resistance R_A of the earth electrode for the installation, and is given in Fig. F12.

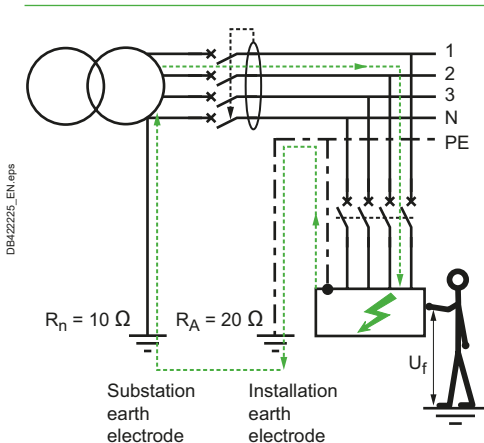


Fig. F11 Automatic disconnection of supply for TT system

$I_{\Delta n}$	Maximum resistance of the earth electrode	
	(50 V)	(25 V)
3 A	16 Ω	8 Ω
1 A	50 Ω	25 Ω
500 mA	100 Ω	50 Ω
300 mA	166 Ω	83 Ω
30 mA	1666 Ω	833 Ω

Fig. F12 The upper limit of resistance for an installation earthing electrode which must not be exceeded, for given sensitivity levels of RCDs at U_L voltage limits of 50 and 25 V

4.2 Practical aspects

Specified maximum disconnecting time

The tripping times of RCDs are generally lower than those required in most national standards; this feature facilitates their use and allows the adoption of an effective selective protection.

IEC 60364-4-41 specifies the maximum operating time of protective devices used in TT system for the protection against indirect contact:

- For all final circuits with a rated current not exceeding 63 A with one or more socket-outlets, and 32 A supplying only fixed connected current-using equipment, the maximum disconnecting time will not exceed the values indicated in Fig. F13
- For all other circuits, the maximum disconnection time is fixed to 1 s. This limit enables selectivity between RCDs when installed on distribution circuits.

4 Implementation of TT system

$U_o^{[a]}$ (VAC)	T (s)
$50 < U_o \leq 120$	0.3
$120 < U_o \leq 230$	0.2
$230 < U_o \leq 400$	0.07
$U_o > 400$	0.04

[a] U_o is the nominal phase to earth voltage

Fig. F13 Maximum disconnecting times in TT system for final circuits not exceeding 63 A with one or more socket-outlets, and 32 A supplying only fixed connected current-using equipment

RCD is a general term for all devices operating on the residual-current principle. RCCB (Residual Current Circuit Breaker) as defined in IEC 61008 series is a specific class of RCD.

General type and S type (Selective) of IEC 61008 have tripping time/current characteristics as shown in Fig. F14. These characteristics allow a certain degree of selective tripping between the several combinations of ratings and types, as shown later in sub-clause 7.5. Industrial type RCD according to IEC 60947-2 provide more possibilities of selectivity due to their flexibility of time-delaying.

$X I \Delta n$		1	2	5	> 5
Domestic	Instantaneous	0.3	0.15	0.04	0.04
	Type S	0.5	0.2	0.15	0.15
Industrial	Instantaneous	0.3	0.15	0.04	0.04
	Time-delay: 0.06s	0.5	0.2	0.15	0.15
	Time-delay (other)	According to manufacturer			

Fig. F14 Maximum operating times of RCDs (in seconds)

Case of distribution circuits (see Fig. F15)

IEC 60364-4-41 and a number of national standards recognize a maximum tripping time of 1 second in installation distribution circuits (as opposed to final circuits). This allows a degree of selectivity to be achieved:

- At level A: Time-delayed RCD, e.g. "S" type
- At level B: Instantaneous RCD.

Case where the exposed conductive parts of an appliance, or group of appliances, are connected to a separate earth electrode (see Fig. F16)

Fault Protection is provided by a RCD at the circuit breaker level protecting each group or separately-earthed individual appliance.

In each case, the sensitivity must be compatible with the resistance of the earth electrode concerned.

Protection when exposed conductive parts are not connected to earth (see Fig. F17)

(In the case of an existing installation where the location is dry and provision of an earthing connection is not possible, or in the event that a protective earth wire becomes broken).

RCDs of high sensitivity (≤ 30 mA) will afford both fault protection (against indirect-contact hazards), and the additional protection against the dangers of contact with live parts (direct contact).

DB422239_EN.eps

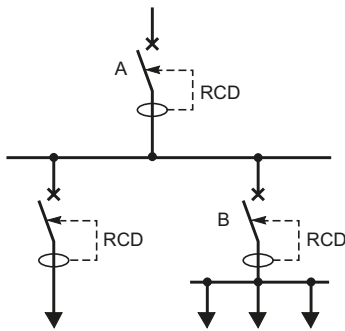


Fig. F15 Distribution circuits

DB422240_EN.eps

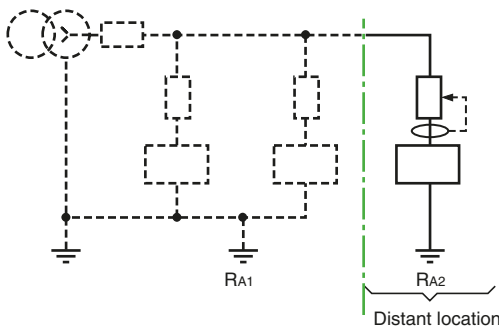


Fig. F16 Separate earth electrode

DB422243.eps

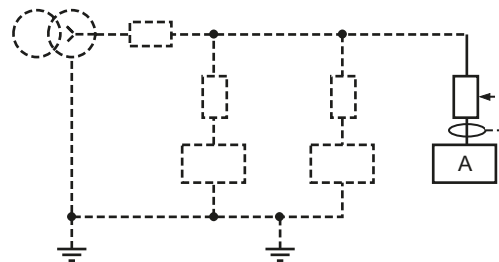


Fig. F17 Unearthed exposed conductive parts (A)

5 Implementation of TN system

The automatic disconnection for TN system is achieved by overcurrent protective devices or RCDs

F10

5.1 Principle

In this system all exposed and extraneous-conductive-parts of the installation are connected directly to the earthed point of the power supply by protective conductors.

As noted in **Chapter E Sub-clause 1.2**, the way in which this direct connection is carried out depends on whether the TN-C, TN-S, or TN-C-S method of implementing the TN principle is used. In **Fig. F18** the method TN-C is shown, in which the neutral conductor acts as both the Protective-Earth and Neutral (PEN) conductor. In all TN systems, any insulation fault to earth results in a phase to neutral short-circuit. High fault current levels allow to use overcurrent protection but can give rise to touch voltages exceeding 50 % of the phase to neutral voltage at the fault position during the short disconnection time.

In practice for utility distribution network, earth electrodes are normally installed at regular intervals along the protective conductor (PE or PEN) of the network, while the consumer is often required to install an earth electrode at the service entrance.

On large installations, additional earth electrodes dispersed around the premises are often provided, in order to reduce the touch voltage as much as possible. In high-rise apartment blocks, all extraneous conductive parts are connected to the protective conductor at each level.

In order to ensure adequate protection, the earth-fault current

$$I_d = \frac{U_o}{Z_s} \text{ or } 0.8 \frac{U_o}{Z_c}$$

must be higher or equal to I_a , where:

- I_d = fault current
- U_o = nominal phase to neutral voltage
- Z_s = earth-fault current loop impedance equal to the sum of the impedance of the source, the phase conductors to the fault position, the protective conductors from the fault position back to the source
- Z_c = the faulty-circuit loop impedance (see "conventional method" Sub-clause 6.3)
- I_a = current equal to the value required to operate the protective device in the specified time

Note: The path through earth electrodes back to the source will have (generally) much higher impedance values than those listed above, and need not be considered.

Example (see Fig. F18)

The fault voltage $U_f = \frac{230}{2} = 115 \text{ V}$ and is hazardous;

The fault loop impedance $Z_s = Z_{AB} + Z_{BC} + Z_{DE} + Z_{EN} + Z_{NA}$.

If Z_{BC} and Z_{DE} are predominant, then:

$$Z_s = 2\rho \frac{L}{S} = 64.3 \text{ m}\Omega, \text{ so that}$$

$$I_d = \frac{230}{64.3 \times 10^{-3}} = 3,576 \text{ A } (\approx 22 \text{ In based on a NSX160 circuit breaker}).$$

The "instantaneous" magnetic trip unit adjustment of the circuit breaker is many times less than this short-circuit value, so that positive operation in the shortest possible time is assured.

Note: Some authorities base such calculations on the assumption that a voltage drop of 20% occurs in the part of the impedance loop BANE.

This method, which is recommended, is explained in sub-clause 5.3 "Fault current calculation - conventional method" and in this example will give an estimated fault current of

$$\frac{230 \times 0.8 \times 10^3}{64.3} = 2,816 \text{ A } (\approx 18 \text{ In}).$$

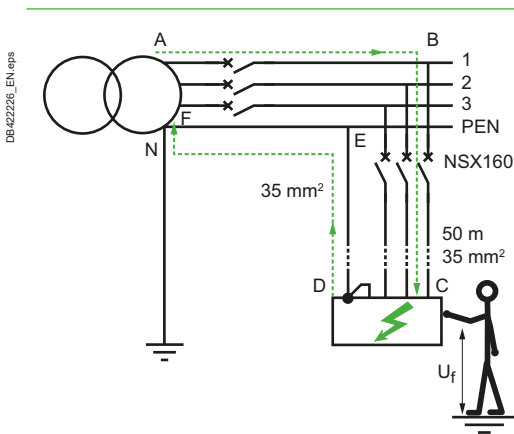


Fig. F18 Automatic disconnection in TN system

5 Implementation of TN system

Specified maximum disconnection time

IEC 60364-4-41 specifies the maximum operating time of protective devices used in TN system for fault protection:

- For all final circuits with a rated current not exceeding 63 A with one or more socket-outlets, and 32 A supplying only fixed connected current-using equipment, the maximum disconnecting time will not exceed the values indicated in Fig. F19
- For all other circuits, the maximum disconnection time is fixed to 5 s. This limit enables selectivity between protective devices installed on distribution circuits

Note: The use of RCDs may be necessary on TN-earthed systems. Use of RCDs on TN-C-S systems means that the protective conductor and the neutral conductor must (evidently) be separated upstream of the RCD. This separation is commonly made at the service entrance.

$U_0^{[a]}$ (V AC)	T (s)
$50 < U_0 \leq 120$	0.8
$120 < U_0 \leq 230$	0.4
$230 < U_0 \leq 400$	0.2
$U_0 > 400$	0.1

[a] U_0 is the nominal phase to earth voltage

Fig. F19 Maximum disconnecting times in TN system for final circuits not exceeding 63 A with one or more socket-outlets, and 32 A supplying only fixed connected current-using equipment

If the protection is to be provided by a circuit breaker, it is sufficient to verify that the fault current will always exceed the current-setting level of the instantaneous or short-time delay tripping unit (I_m)

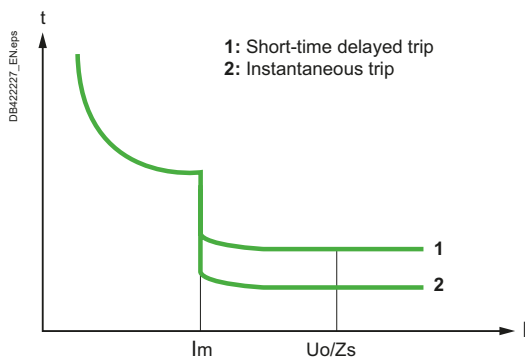


Fig. F20 Disconnection by circuit breaker for a TN system

Protection by means of circuit breaker (see Fig. F20)

The instantaneous trip unit of a circuit breaker will eliminate a fault to earth in less than 0.1 second.

In consequence, automatic disconnection within the maximum allowable time will always be assured, since all types of trip unit, magnetic or electronic, instantaneous or slightly retarded, are suitable: $I_a = I_m$. The maximum tolerance authorized by the relevant standard, however, must always be taken into consideration. It is sufficient therefore that the fault current U_0/Z_s or $0.8 U_0/Z_c$ determined by calculation (or estimated on site) be greater than the instantaneous trip-setting current I_m , or greater than the very short-time tripping threshold level, to be sure of tripping within the permitted time limit.

5 Implementation of TN system

I_s can be determined from the fuse performance curve. In any case, protection cannot be achieved if the loop impedance Z_s or Z_c exceeds a certain value

Protection by means of fuses (see Fig. F21)

The value of current which assures the correct operation of a fuse can be ascertained from a current/time performance graph for the fuse concerned.

The fault current U_0/Z_s or $0.8 U_0/Z_c$ as determined above, must largely exceed the current necessary to ensure positive operation of the fuse. The condition to observe therefore is that

$$I_a < \frac{U_0}{Z_s} \text{ or } 0.8 \frac{U_0}{Z_c} \text{ as indicated in Fig. F21.}$$

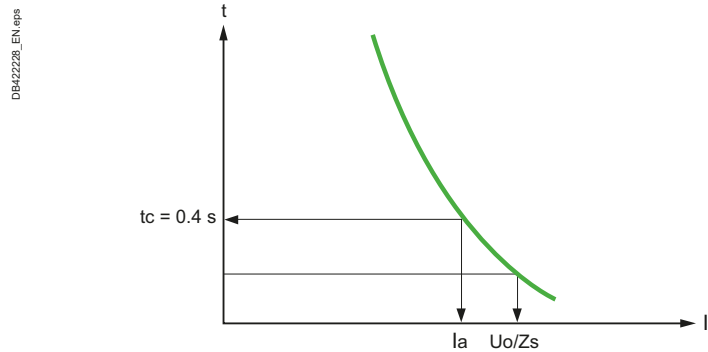


Fig. F21 Disconnection by fuses for a TN system

Example: The nominal phase to neutral voltage of the network is 230 V and the maximum disconnection time given in Fig. F19 is 0.4 s.

The corresponding value of I_a can be read from the graph. Using the voltage (230 V) and the current I_a , the complete loop impedance or the circuit loop impedance can be calculated from:

$$Z_s = \frac{230}{I_a} \text{ or } Z_c = 0.8 \frac{230}{I_a}$$

This impedance value must never be exceeded and should preferably be substantially less to ensure satisfactory fuse operation.

Protection by means of Residual Current Devices (not applicable for TN-C)

Residual Current Devices must be used where:

- The loop impedance cannot be determined precisely (lengths difficult to estimate, presence of metallic material close to the wiring)
- The fault current is so low that the disconnection time cannot be met by using overcurrent protective devices

The rated tripping current of RCDs being in the order of a few amps, it is well below the fault current level. RCDs are consequently well adapted to this situation.

In practice, they are often installed in the LV sub-distribution and in many countries, the automatic disconnection of final circuits shall be achieved by Residual Current Devices.

5 Implementation of TN system

5.2 Preliminary conditions

At the design stage, the maximum permitted lengths of cable downstream of a protective circuit breaker (or set of fuses) must be calculated, while during the installation work, certain rules must be fully respected.

Certain conditions must be observed, as listed below and illustrated in **Fig. F22**.

1. PE conductor must be regularly connected to earth as much as possible.
2. The PE conductor must not pass through ferromagnetic conduit, ducts, etc. or be mounted on steel work, since inductive and/or proximity effects can increase the effective impedance of the conductor.
3. In the case of a PEN conductor (a neutral conductor which is also used as a protective conductor), connection must be made directly to the earth terminal of an appliance (see 3 in **Fig. F22**) before being looped to the neutral terminal of the same appliance.
4. Where the conductor $\leq 6 \text{ mm}^2$ for copper or 10 mm^2 for aluminium, or where a cable is movable, the neutral and protective conductors should be separated (i.e. a TN-S system should be adopted within the installation).
5. Earth faults may be cleared by overcurrent-protection devices, i.e. by fuses or circuit breakers.

The foregoing list indicates the conditions to be respected in the implementation of a TN scheme for fault protection.

F13

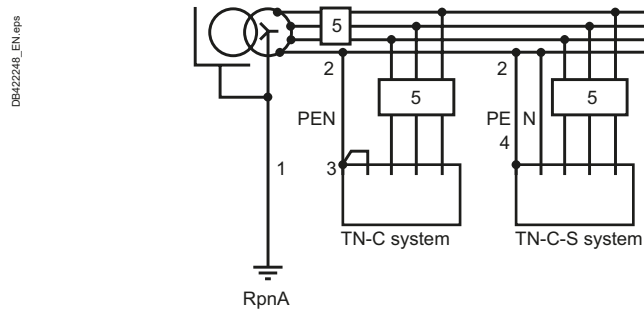


Fig. F22 Implementation of the TN earthing system

Notes:

- The TN scheme requires that the LV neutral of the MV/LV transformer, the exposed conductive parts of the substation and of the installation, and the extraneous conductive parts in the substation and installation, all be earthed to a common earthing system.
- For a substation in which the metering is at low-voltage level, a means of isolation is required at the origin of the LV installation, and the isolation must be clearly visible.
- A PEN conductor must never be interrupted under any circumstances.

Control and protective switchgear for the several TN arrangements will be:

- 3-pole when the circuit includes a PEN conductor,
- Preferably 4-pole (3 phases + neutral) when the circuit includes a neutral with a separate PE conductor.

5 Implementation of TN system

5.3 Earth-fault current calculation

Methods of determining levels of fault current

In TN-earthed systems, a fault to earth will, in principle, provide sufficient current to operate an overcurrent device.

The source and supply mains impedances are much lower than those of the installation circuits, so that any restriction in the magnitude of earth-fault currents will be mainly caused by the installation conductors (long flexible leads to appliances greatly increase the “fault-loop” impedance, with a corresponding reduction of the fault current).

The most recent IEC recommendations for fault protection on TN earthing systems only relates maximum allowable tripping times to the nominal system voltage (see Fig. F13).

The reasoning behind these recommendations is that, for TN systems, the current which must flow in order to raise the potential of an exposed conductive part to 50 V or more is so high that one of two possibilities will occur:

- Either the fault path will blow itself clear, practically instantaneously, or
- The conductor will weld itself into a solid fault and provide adequate current to operate overcurrent devices.

To ensure correct operation of overcurrent devices in the latter case, a reasonably accurate assessment of earth-fault current levels must be determined at the design stage of a project.

A rigorous analysis requires the use of phase-sequence-component techniques applied to every circuit in turn. The principle is straightforward, but the amount of computation is not considered justifiable, especially since the zero-phase sequence impedances are extremely difficult to determine with any reasonable degree of accuracy in an average LV installation.

Other simpler methods of adequate accuracy are preferred.

Three practical methods are:

- The “**method of impedances**”, based on the summation of all the impedances (positive-phase-sequence only) around the fault loop, for each circuit
- The “**method of composition**”, which is an estimation of short-circuit current at the remote end of a loop, when the short-circuit current level at the near end of the loop is known
- The “**conventional method**” of calculating the minimum levels of earth-fault currents, together with the use of tables of values for obtaining rapid results.

These methods are only reliable for the case in which the cables that make up the earth-fault-current loop are in close proximity (to each other) and not separated by ferromagnetic materials.

Note: Schneider Electric’s Ecodial software is based on the “method of impedances”.

Method of impedances

This method summates the positive-sequence impedances of each item (cable, PE conductor, transformer, etc.) included in the earth-fault loop circuit from which the earth-fault current is calculated, using the formula:

$$I = \frac{U_0}{\sqrt{(\sum R)^2 + (\sum X)^2}}$$

Where

U_0 = nominal system phase-to-neutral voltage.

$(\sum R)^2$ = (sum of all resistances in the loop)² at the design stage of a project.

$(\sum X)^2$ = (the sum of all inductive reactances in the loop)²

The application of the method is not always easy, because it supposes a knowledge of all parameter values and characteristics of the elements in the loop. In many cases, a national guide can supply typical values for estimation purposes.

[1] This results in a calculated current value which is less than what would actually flow. If the overcurrent settings are based on this calculated value, then operation of the relay, or fuse, is assured.

5 Implementation of TN system

Method of composition

This method permits the determination of the short-circuit current at the end of a loop from the known value of short-circuit at the sending end, by means of the approximate formula:

$$I_{sc} = \frac{I \cdot U_0}{U_0 + Z_s \cdot I}$$

where

I_{sc} = end-of-loop short-circuit current

I = upstream short-circuit current

U_0 = nominal system phase voltage

Z_s = impedance of loop

Note: in this method, the individual impedances are added arithmetically [1] as opposed to the previous "method of impedances" procedure.

Conventional method

This method is generally considered to be sufficiently accurate to fix the upper limit of cable lengths.

Principle

The short-circuit current calculation is based on the assumption that the voltage at the origin of the circuit concerned (i.e. at the point at which the circuit protective device is located) remains at 80% or more of the nominal phase to neutral voltage. The 80% value is used, together with the circuit loop impedance, to compute the short-circuit current.

This coefficient takes all voltage drops upstream of the point considered. In LV cables, when all conductors of a 3-phase 4-wire circuit are in close proximity (which is the normal case), the inductive reactance internal to and between conductors is negligibly small compared to the cable resistance.

This approximation is considered to be valid for cable sizes up to 120 mm².

Above that size, the resistance value R is increased as follows:

Core size (mm ²)	Value of resistance
S = 150 mm ²	R+15%
S = 185 mm ²	R+20%
S = 240 mm ²	R+25%

The maximum length of a circuit in a TN-earthed installation is given by the formula:

$$L_{max} = \frac{0.8 U_0 S_{ph}}{\rho(1+m)I_a}$$

where:

L_{max} = maximum length in meters

U_0 = phase volts = 230 V for a 230/400 V system

ρ = resistivity at normal working temperature in ohm.mm²/meter
(= 23.7 x 10⁻³ for copper; = 37.6 x 10⁻³ for aluminium)

I_a = trip current of the circuit breaker which guarantees instantaneous operation (see note below),

or:

I_a = the current which assures operation of the protective fuse concerned, in the specified time.

S_{ph} = cross-sectional area of the phase conductors of the circuit concerned in mm²

S_{PE} = cross-sectional area of the protective conductor concerned in mm².

$$m = \frac{S_{ph}}{S_{PE}}$$

(see Fig. F23)

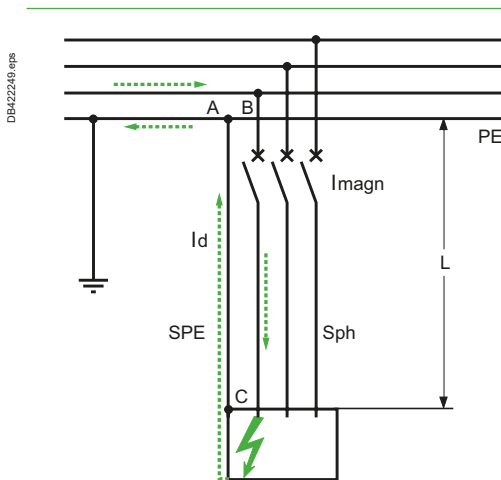


Fig. F23 Calculation of L max. for a TN-earthed system, using the conventional method

[1] This results in a calculated current value which is less than what would actually flow. If the overcurrent settings are based on this calculated value, then operation of the relay, or fuse, is assured.

5 Implementation of TN system

Tables

The following tables, applicable to TN systems, have been established according to the “conventional method” described above.

The tables give maximum circuit lengths, beyond which the ohmic resistance of the conductors will limit the magnitude of the short-circuit current to a level below that required to trip the circuit breaker (or to blow the fuse) protecting the circuit, with sufficient rapidity to ensure fault protection.

Note: for industrial circuit breakers (IEC 60947-2), a 20% tolerance is taken concerning the magnetic trip current, i.e. the real trip level I_a may be 20% higher (or lower) than the magnetic trip setting I_m of the circuit breaker. Table Fig. F25 includes this 20% tolerance and calculates the maximum length of the circuit for the worst-case, which is for $I_a = I_m \times 1.2$. For **domestic circuit breakers (IEC 60898)**, the tripping value is stated without tolerance (for example, $I_a = I_m = 10 I_n$ for C curve), so Tables Fig. F26 to Fig. F28 are calculated with short-circuit value exactly equal to I_m , without tolerance.

Correction factor m

Fig. F24 indicates the correction factor to apply to the values given in Fig. F25 to Fig. F28, according to the ratio S_{ph}/S_{PE} , the type of circuit, and the conductor materials.

The tables take into account:

- The type of protection: circuit breakers or fuses
- Operating-current settings
- Cross-sectional area of phase conductors and protective conductors
- Type of earthing system (see Fig. F16)
- Type of circuit breaker (i.e. B, C or D)^[1]

The tables may be used for 230/400 V systems.

Similar tables for protection by Schneider Electric Compact and Acti 9 circuit breakers are included in the relevant catalogues.

Circuit	Conductor material	m = S _{ph} /S _{PE} (or PEN)			
		m = 1	m = 2	m = 3	m = 4
3P+N or P+N	Copper	1	0.67	0.50	0.40
	Aluminium	0.62	0.42	0.31	0.25

Fig. F24 Correction factor to apply to the lengths given in tables Fig. F25 to Fig. F28 for TN systems

Nominal cross-sectional area of conductors mm ²	Instantaneous or short-time-delayed CB tripping current setting I_m (amperes)																													
	50	63	80	100	125	160	200	250	320	400	500	560	630	700	800	875	1000	1120	1250	1600	2000	2500	3200	4000	5000	6300	8000	10000	12500	
1.5	100	79	63	50	40	31	25	20	16	13	10	9	8	7	6	6	5	4	4											
2.5	167	133	104	83	67	52	42	33	26	21	17	15	13	12	10	10	8	7	7	5	4									
4	267	212	167	133	107	83	67	53	42	33	27	24	21	19	17	15	13	12	11	8	7	5	4							
6	400	317	250	200	160	125	100	80	63	50	40	36	32	29	25	23	20	18	16	13	10	8	6	5	4					
10			417	333	267	208	167	133	104	83	67	60	53	48	42	38	33	30	27	21	17	13	10	8	7	5	4			
16				427	333	267	213	167	133	107	95	85	76	67	61	53	48	43	33	27	21	17	13	11	8	7	5	4		
25					417	333	260	208	167	149	132	119	104	95	83	74	67	52	42	33	26	21	17	13	10	8	7			
35						467	365	292	233	208	185	167	146	133	117	104	93	73	58	47	36	29	23	19	15	12	9			
50							495	396	317	283	251	226	198	181	158	141	127	99	79	63	49	40	32	25	20	16	13			
70								417	370	333	292	267	233	208	187	146	117	93	73	58	47	37	29	23	19	15	12			
95									452	396	362	317	283	263	198	158	127	99	79	63	50	40	32	25	20	16	13			
120										457	400	357	320	250	200	160	125	100	80	63	50	40	32	25	20	16	13			
150											435	388	348	272	217	174	136	109	87	69	54	43	35	28	22	17	14			
185												459	411	321	257	206	161	128	103	82	64	51	41	33	26	20	16	13		
240																400	320	256	200	160	128	102	80	64	51	41	33			

Note: this table is calculated according to IEC60947-2, thus includes a 20% tolerance on the actual tripping current compared to the circuit breaker tripping setting (see upper note)

Fig. F25 Maximum circuit lengths (in metres) for different sizes of copper conductor and instantaneous-tripping-current settings for industrial circuit breakers (IEC 60947-2) in 230/400 V TN system with m = 1

[1] For the definition of type B, C, D circuit breakers, refer to chapter H, clause 4.2

5 Implementation of TN system

Sph mm ²	Rated current (A)															
	1	2	3	4	6	10	16	20	25	32	40	50	63	80	100	125
1.5	1200	600	400	300	200	120	75	60	48	37	30	24	19	15	12	10
2.5		1000	666	500	333	200	125	100	80	62	50	40	32	25	20	16
4			1066	800	533	320	200	160	128	100	80	64	51	40	32	26
6				1200	800	480	300	240	192	150	120	96	76	60	48	38
10						800	500	400	320	250	200	160	127	100	60	102
16							800	640	512	400	320	256	203	160	128	102
25									800	625	500	400	317	250	200	160
35										875	700	560	444	350	280	224
50												760	603	475	380	304

Fig. F26 Maximum circuit lengths (in metres) for different sizes of copper conductor and rated currents for type B ^[1] domestic circuit breakers (IEC 60898) in a 230/400 V single-phase or three-phase TN system with m = 1

Sph mm ²	Rated current (A)															
	1	2	3	4	6	10	16	20	25	32	40	50	63	80	100	125
1.5	600	300	200	150	100	60	37	30	24	18	15	12	9	7	6	5
2.5		500	333	250	167	100	62	50	40	31	25	20	16	12	10	8
4			533	400	267	160	100	80	64	50	40	32	25	20	16	13
6				600	400	240	150	120	96	75	60	48	38	30	24	19
10					667	400	250	200	160	125	100	80	63	50	40	32
16						640	400	320	256	200	160	128	101	80	64	51
25							625	500	400	312	250	200	159	125	100	80
35							875	700	560	437	350	280	222	175	140	112
50									760	594	475	380	301	237	190	152

Fig. F27 Maximum circuit lengths (in metres) for different sizes of copper conductor and rated currents for type C ^[1] domestic circuit breakers (IEC 60898) in a 230/400 V single-phase or three-phase TN system with m = 1

Sph mm ²	Rated current (A)															
	1	2	3	4	6	10	16	20	25	32	40	50	63	80	100	125
1.5	429	214	143	107	71	43	27	21	17	13	11	9	7	5	4	3
2.5	714	357	238	179	119	71	45	36	29	22	18	14	11	9	7	6
4		571	381	286	190	114	71	57	46	36	29	23	18	14	11	9
6		857	571	429	286	171	107	86	69	54	43	34	27	21	17	14
10			952	714	476	286	179	143	114	89	71	57	45	36	29	23
16					762	457	286	229	183	143	114	91	73	57	46	37
25						714	446	357	286	223	179	143	113	89	71	57
35							625	500	400	313	250	200	159	125	100	80
50								679	543	424	339	271	215	170	136	109

Fig. F28 Maximum circuit lengths (in metres) for different sizes of copper conductor and rated currents for type D ^[1] domestic circuit breakers (IEC 60898) in a 230/400 V single-phase or three-phase TN system with m = 1

Example:

A 3-phase 4-wire (230/400 V) installation is TN-C earthed. A circuit is protected by a type B circuit breaker rated at 63 A, and consists of an aluminium core cable with 50 mm² phase conductors and a neutral conductor (PEN) of 25 mm².

What is the maximum length of circuit, below which fault protection is assured by the instantaneous magnetic tripping relay of the circuit breaker?

Fig. F26 gives, for 50 mm² and a 63 A type B circuit breaker, 603 meters, to

which must be applied a factor of 0.42 (Fig. F24 for $m = \frac{S_{ph}}{S_{PE}} = 2$)

The maximum length of circuit is therefore:
603 x 0.42 = 253 meters.

Particular case where one (or more) exposed conductive part(s) is (are) earthed to a separate earth electrode

Fault Protection must be provided by a RCD at the origin of any circuit supplying an appliance or group of appliances, the exposed conductive parts of which are connected to an independent earth electrode.

The sensitivity of the RCD must be adapted to the earth electrode resistance (R_{A2} in Fig. F16). See specifications applicable to TT system.

[1] For the definition of type B, C, D circuit breakers, refer to chapter H, clause 4.2

5 Implementation of TN system

DB42250_EN.eps

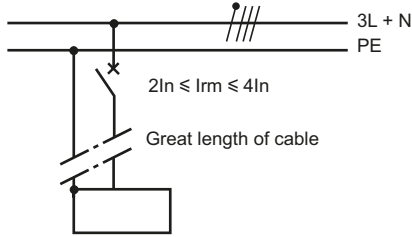


Fig. F29 Circuit breaker with low-set instantaneous magnetic tripping

DB42251_EN.eps

F18

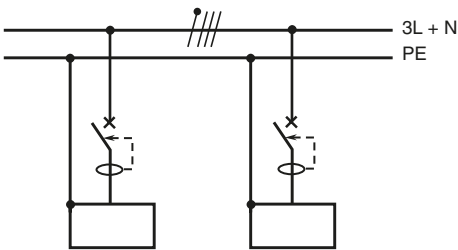


Fig. F30 RCD protection on TN systems with high earth-fault-loop impedance

5.4 High fault current-loop impedance

When the earth-fault current is limited due to an inevitably high fault-loop impedance, so that the overcurrent protection cannot be relied upon to trip the circuit within the prescribed time, the following possibilities should be considered:

Suggestion 1 (see Fig. F29)

- Install a circuit breaker which has a lower instantaneous magnetic tripping level, for example:
 $2I_n \leq I_{rm} \leq 4I_n$

This affords protection for persons on circuits which are abnormally long. It must be checked, however, that high transient currents such as the starting currents of motors will not cause nuisance trip-outs.

- Schneider Electric solutions
 - Type G Compact ($2I_n \leq I_{rm} \leq 4I_n$)
 - Type B Acti 9 circuit breaker

Suggestion 2 (see Fig. F30)

- Install a RCD on the circuit. The device does not need to be highly-sensitive (HS) (several amps to a few tens of amps). Where socket-outlets are involved, the particular circuits must, in any case, be protected by HS (≤ 30 mA) RCDs; generally one RCD for a number of socket outlets on a common circuit.

- Schneider Electric solutions
 - RCD Vigi NG125 : $I_{\Delta n} = 1$ or 3 A
 - Vigicomact REH or REM: $I_{\Delta n} = 3$ to 30 A
 - Type B Acti 9 circuit breaker

Suggestion 3

Increase the size of the PE or PEN conductors and/or the phase conductors, to reduce the loop impedance.

Suggestion 4

Add supplementary equipotential conductors. This will have a similar effect to that of suggestion 3, i.e. a reduction in the earth-fault-loop resistance, while at the same time improving the existing touch-voltage protection measures. The effectiveness of this improvement may be checked by a resistance test between each exposed conductive part and the local main protective conductor.

For TN-C installations, bonding as shown in Fig. F31 is not allowed, and suggestion 3 should be adopted.

DB42252_EN.eps

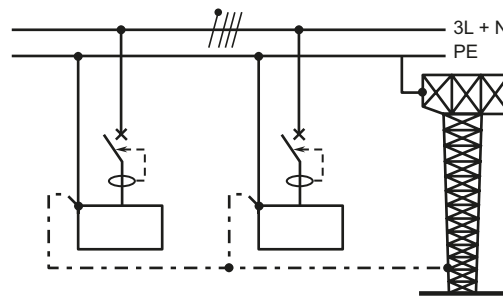


Fig. F31 Improved equipotential bonding

6 Implementation of IT system

6.1 Principle

In this type of system:

- The installation is isolated from earth, or the neutral point of its power-supply source is connected to earth through a high impedance (commonly 1500 Ω or more)
- All exposed and extraneous-conductive-parts are earthed via an installation earth electrode.

The basic feature of IT earthing system is that, in the event of a fault between phases and earth, the system can continue to operate without interruption. Such a fault is referred to as a "first fault".

The first fault current value depends on the neutral impedance (if any) and on downstream network capacitances (cables, filtering, leakage...). The first fault current I_d should be low enough to meet the rule $I_d \cdot R_A \leq 50 \text{ V}$, so that no dangerous fault voltages can occur.

The system may be allowed to operate normally until it is convenient to isolate the faulty section for repair work. This enhances continuity of service.

In practice, IT system requires certain specific measures for its satisfactory exploitation:

- Permanent monitoring of the insulation with respect to earth, which must signal (audibly or visually) the occurrence of the first fault
- A device for limiting the voltage which the neutral point of the supply transformer can reach with respect to earth
- A "first-fault" location routine by an efficient maintenance staff. Fault location is greatly facilitated by automatic devices which are currently available.
- Automatic high-speed tripping of appropriate circuit breakers must take place in the event of a "second fault" occurring before the first fault is repaired. The second fault (by definition) is an earth fault affecting a different live conductor than that of the first fault (can be a phase or neutral conductor on systems where the neutral is distributed, see Fig. F39).

F19

6.2 Fault protection

First fault situation

In IT system, the first fault to earth should not cause any disconnection.

The earth-fault current which flows under a first-fault condition is measured in mA.

Two different examples of earth-fault current calculation are presented below .

Example 1

In the simplified circuit presented on Fig. F32, the neutral point of the power-supply source is connected to earth through a 1500 Ω resistance. The current through the earthing resistor will be 153 mA in case of a fault (on a 230/400 V 3-phase system). The fault voltage with respect to earth due to this current is the product of this current and the resistance of the PE conductor plus earthing resistor (from the faulted component to the electrode), which is negligible.

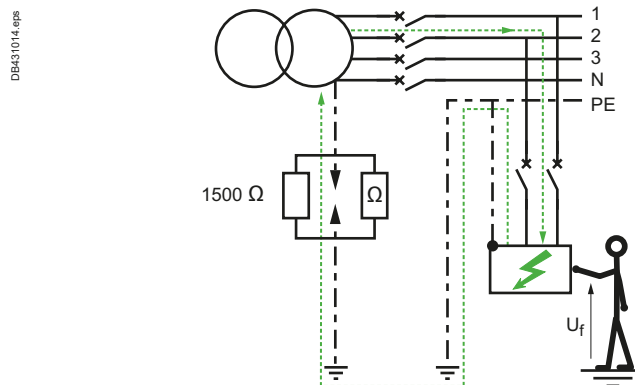


Fig. F32 Simplified circuit

6 Implementation of IT system

F20

Example 2

For a network formed of 1 km of conductors as represented on Fig. F33, the leakage impedance to earth ($\approx 1 \mu\text{F} / \text{km}$) is represented by the capacitors C_1 to C_N . The capacitive impedance Z_C is in the order of 3500Ω per phase. In normal operation, the capacitive current [1] to earth is therefore:

$$I_c = \frac{U_0}{Z_C} = \frac{230}{3500} = 66 \text{ mA per phase}$$

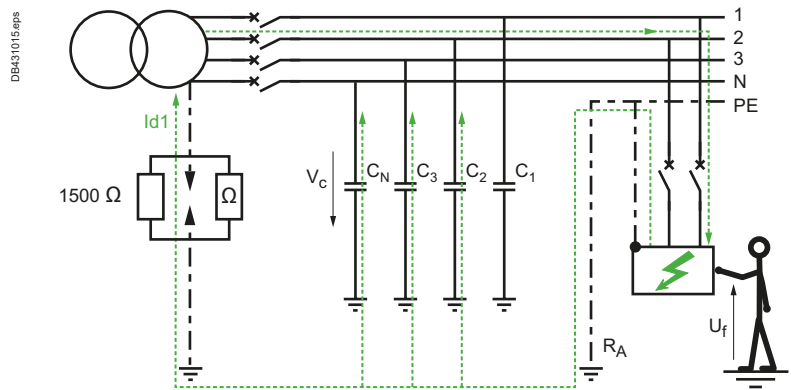


Fig. F33 Fault current path for a first fault in IT system

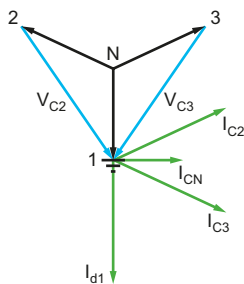


Fig. F34 Vector representation of voltages and currents in case of fault between phase 1 and earth

During a fault between phase 1 and earth as in Fig. F33, the voltage and current vectors can be represented as shown on Fig. F34.

The fault current passing through the electrode resistance R_A is the vector sum of the currents:

- Capacitive currents in the two healthy phases I_{C2} and I_{C3} ,
- Capacitive current in the neutral I_{CN} ,
- Current in the neutral impedance, I_{d1} .

The voltages of the healthy phases have (because of the fault) increased to $\sqrt{3}$ times the normal phase voltage, so that the capacitive currents increase by the same amount: $I_{C2} = I_{C3} = I_C \cdot \sqrt{3} = 66 \times \sqrt{3} = 114 \text{ mA}$

The neutral voltage is 230V, so the capacitive neutral current is: $I_{CN} = I_C = 66 \text{ mA}$

These currents are displaced one from the other by 30° , so that the total vector addition I_{d2} amounts to:

$$2(I_C \cdot \sqrt{3}) \cdot \frac{\sqrt{3}}{2} + I_C = 3 \cdot I_C + I_C = 4 \cdot I_C = 4 \times 66 = 264 \text{ mA}$$

e.g. for 3L+N circuits, the capacitive current to earth value increases by a factor of 4 during phase-to-earth fault, compared to its value in normal operation I_C

The current I_{d1} through the neutral resistance is 153 mA (see simplified example above)

The current through the fault to earth is given by the vector sum of the neutral-resistor current I_{d1} (= 153 mA) and the capacitive current I_{d2} (= 264 mA).

It is then equal to: $\sqrt{153^2 + 264^2} = 304 \text{ mA}$

Considering for example an earthing resistance R_A equal to 50Ω , the fault voltage U_f is therefore equal to:

$50 \times 304 \times 10^{-3} = 15.2 \text{ V}$, which is obviously harmless.

[1] Resistive leakage current to earth through the insulation is assumed to be negligibly small in this example.

6 Implementation of IT system

Recommendation

To take full benefit of the continuity of service on first-fault condition provided by the IT system:

- A permanent monitoring of the insulation to earth must be provided, coupled with an alarm signal (audio and/or flashing lights, etc.) operating in the event of a first earth fault (see Fig. F35)
- The location and repair of a first fault is imperative if the full benefits of the IT system are to be realized. Continuity of service is the great advantage afforded by the system. As continuity of service is provided, it is not mandatory to repair the fault immediately, avoiding to operate under stress and urgency.

PB 116742_aps



Fig. F35 Example of phase-to-earth Insulation Monitoring Device used in IT system

F21

Second fault situation

The second fault results in a short-circuit between active conductors (phases or neutral) through the earth and/or through PE bonding conductors (unless occurring on the same conductor as the first fault). Overcurrent protective devices (fuses or circuit breakers) would normally operate an automatic fault clearance.

Particularities and limitations specific to IT system are given in section 6.3.

Fault clearance is carried out differently in each of the following cases (see Fig. F36):

DB42231_EN_aps

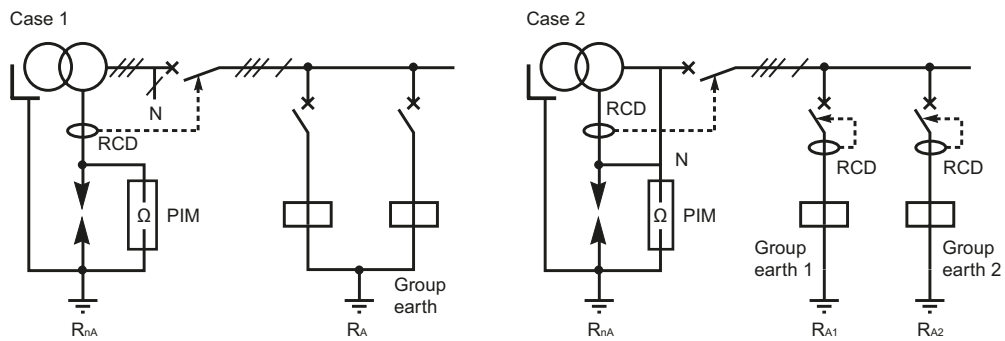


Fig. F36 Two different situations to be considered

6 Implementation of IT system

1st case

It concerns an installation in which all exposed conductive parts are bonded to a common PE conductor, as shown in Fig. F37.

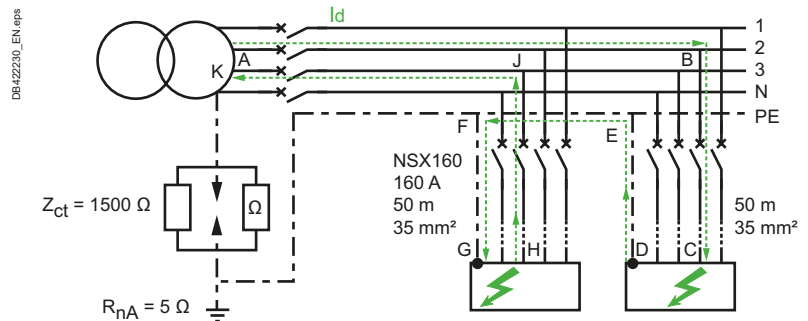


Fig. F37 Circuit breaker tripping on double fault situation when exposed-conductive-parts are connected to a common protective conductor

In this case, no earth electrodes are included in the fault current path, so that a high level of fault current is assured, and conventional overcurrent protective devices are used, i.e. circuit breakers and fuses.

To adjust the protective devices, the short-circuit current must be calculated, using one of the different methods applicable to TN system, as already presented in section 5.3:

- Methods of impedance
- Method of composition
- Conventional method

The first fault could occur at the end of a circuit in a remote part of the installation, while the second fault could feasibly be located at the opposite end of the installation.

For this reason, it is conventional to double the loop impedance of a circuit, when calculating the anticipated fault setting level for its overcurrent protective device(s).

Where the system includes a neutral conductor in addition to the 3 phase conductors, the lowest short-circuit fault currents will occur if one of the (two) faults is from the neutral conductor to earth (all four conductors are insulated from earth in an IT scheme). In four-wire IT installations, therefore, the phase-to-neutral voltage must be used to calculate short-circuit protective levels i.e. :

$$0.8 \frac{U_0}{2 Z_c} \geq I_a^{[1]}$$

Where:

U_0 = phase to neutral voltage

Z_c = impedance of the circuit fault-current loop (see 5.1)

I_a = current level for trip setting

If no neutral conductor is distributed, then the voltage to use for the fault-current calculation is the phase-to-phase value, i.e.

$$0.8 \frac{\sqrt{3} U_0}{2 Z_c} \geq I_a^{[1]}$$

The settings of overcurrent tripping relays and the ratings of fuses are the basic parameters that decide the maximum practical length of circuit that can be satisfactorily protected, as discussed in section 5.3.

Note: In normal circumstances, the fault current path is through common PE conductors, bonding all exposed conductive parts of an installation, and so the fault loop impedance is sufficiently low to ensure an adequate level of fault current.

[1] Based on the "conventional method", see section 6.3.

6 Implementation of IT system

2nd case

It concerns exposed **conductive parts which are earthed either individually** (each part having its own earth electrode) **or in separate groups** (one electrode for each group). If all exposed conductive parts are not bonded to a common electrode system, then it is possible for the second earth fault to occur in a different group or in a separately earthed individual apparatus.

Rules of TT system apply.

Additional protection to that described above for case 1, is required, and consists of a RCD associated to the circuit breaker controlling each group and each individually-earthed apparatus.

The reason for this requirement is that the separate-group electrodes are “bonded” through the earth so that the phase to phase short-circuit current will generally be limited when passing through the earth bond by the electrode contact resistances with the earth, thereby making protection by overcurrent devices unreliable.

The more sensitive RCDs are therefore necessary, but the operating current of the RCDs must evidently exceed that which occurs for a first fault (see [Fig. F38](#)).

Leakage capacitance (μF)	First fault current (A)
1	0.07
5	0.36
30	2.17

Note: 1 μF is the 1 km typical leakage capacitance for 4-conductor cable

Fig. F38 Correspondence between the eath leakage capacitance and the first fault current.

Note 1: See also: Protection of the neutral conductor (**Chapter G**, sub-clause 7.2).

Note 2: In 3-phase 4-wire installations, protection against overcurrent in the neutral conductor is sometimes more conveniently achieved by using a ring-type current transformer over the single-core neutral conductor (see [Fig. F36](#)).

[1] Based on the “conventional method”. See 6.3

6 Implementation of IT system

6.3 Implementation of protections

Protection by circuit breaker

In the case shown in **Fig. F37**, the adjustments of instantaneous and short-time delay overcurrent trip unit must be decided. The short-circuit protection provided by the NSX160 circuit breaker is suitable to clear a phase to phase short-circuit occurring at the load ends of the circuits concerned.

Reminder: In an IT system, the two circuits involved in a phase to phase short-circuit are assumed to be of equal length, with the same cross sectional area conductors, the PE conductors being the same cross sectional area as the phase conductors. In such a case, the impedance of the circuit loop when using the Conventional method be twice that calculated for one of the circuits in the TN case.

The resistance of circuit loop $FGHJ = 2 R_{JH} = 2\rho \frac{L}{a}$ in $m\Omega$

where:

ρ = resistance of copper rod 1 meter long of cross sectional area 1 mm^2 , in $m\Omega$

L = length of the circuit in meters

a = cross sectional area of the conductor in mm^2

$FGHJ = 2 \times 23.7 \times 50/35 = 67.7 \text{ m}\Omega$ and the loop resistance B, C, D, E, F, G, H, J will be $2 \times 67.7 = 135 \text{ m}\Omega$.

Therefore the fault current will be

$$0.8 \times \sqrt{3} \times 230 \times 10^3 / 135 = 2361 \text{ A.}$$

Protection by fuses

The current I_a for which fuse operation must be assured in a time specified according to here above can be found from fuse operating curves, as described in **Fig. F21**.

The current indicated should be significantly lower than the fault currents calculated for the circuit concerned.

Protection by Residual Current Devices (RCDs)

Where circuit lengths are unavoidably long, and especially if the appliances of a circuit are earthed separately (so that the fault current passes through two earth electrodes), reliable tripping on overcurrent may not be possible.

In this case, an RCD is recommended on each circuit of the installation.

Where an IT system is resistance earthed, however, care must be taken to ensure that the RCD is not too sensitive, or a first fault may cause an unwanted trip-out.

Tripping of residual current devices which satisfy IEC standards may occur at values of $0.5 I_{\Delta n}$ to $I_{\Delta n}$, where $I_{\Delta n}$ is the nominal residual-current setting level.

Maximum circuit length

The principle is the same for an IT system as that described for a TN system: the calculation of maximum circuit lengths which should not be exceeded downstream of a circuit breaker or fuses, to ensure protection by overcurrent devices.

It is clearly impossible to check circuit lengths for every feasible combination of two concurrent faults.

All cases are covered, however, if the overcurrent trip setting is based on the assumption that a first fault occurs at the remote end of the circuit concerned, while the second fault occurs at the remote end of an identical circuit, as already mentioned. This may result, in general, in one trip-out only occurring (on the circuit with the lower trip-setting level), thereby leaving the system in a first-fault situation, but with one faulty circuit switched out of service.

6 Implementation of IT system

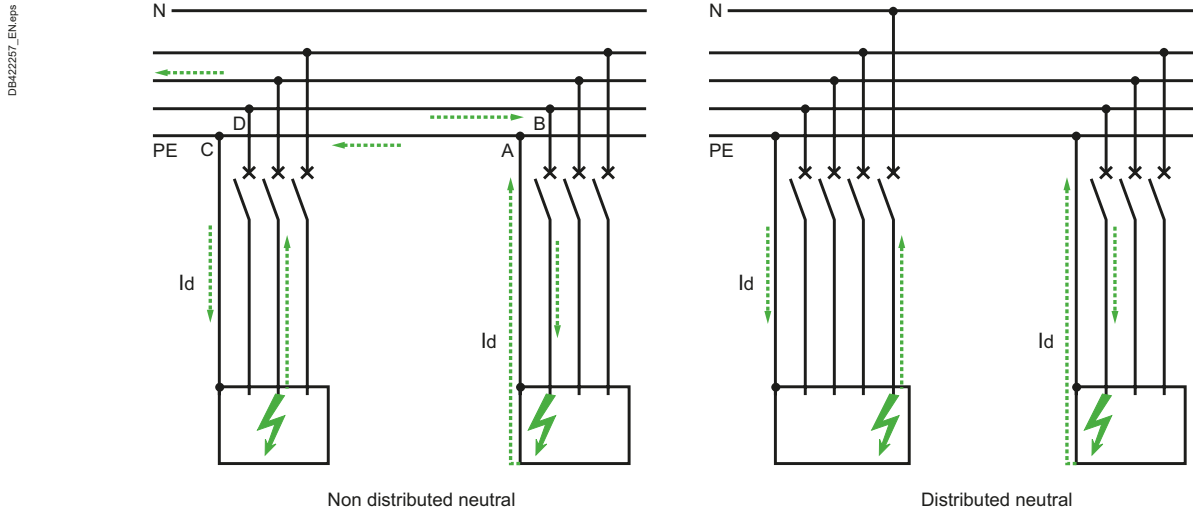


Fig. F39 Calculation of L_{max} for an IT-earthed system, showing fault-current path for a double-fault condition

- For the case of a 3-phase 3-wire installation the second fault can only cause a phase/phase short-circuit, so that the voltage to use in the formula for maximum circuit length is $\sqrt{3} U_0$.

The maximum circuit length is given by:

$$L_{max} = \frac{0.8 U_0 \sqrt{3} S_{ph}}{2 \rho I_a (1+m)} \text{ metres}$$

- For the case of a 3-phase 4-wire installation the lowest value of fault current will occur if one of the faults is on a neutral conductor. In this case, U_0 is the value to use for computing the maximum cable length, and

$$L_{max} = \frac{0.8 U_0 S_1}{2 \rho I_a (1+m)} \text{ metres}$$

i.e. 50% only of the length permitted for a TN scheme^[1]

In the preceding formulae:

L_{max} = longest circuit in metres

U_0 = phase-to-neutral voltage (230 V on a 230/400 V system)

ρ = resistivity at normal operating temperature (23.7 x 10⁻³ Ω·mm²/m for copper, 37.6 x 10⁻³ Ω·mm²/m for aluminium)

I_a = overcurrent trip-setting level in amps,

or:

I_a = current in amps required to clear the fuse in the specified time

$$m = \frac{S_{ph}}{S_{PE}}$$

S_{ph} = cross-sectional area of the phase conductors of the circuit concerned in mm²

S_{PE} = cross-sectional area of PE conductor in mm²

S_1 = S neutral if the circuit includes a neutral conductor

S_1 = S_{ph} if the circuit does not include a neutral conductor

[1] Reminder: There is no length limit for earth-fault protection on a TT scheme, since protection is provided by RCDs of high sensitivity.

6 Implementation of IT system

Tables

The tables shown in **Fig. F25** to **Fig. F28** have been established according to the “conventional method” described in section 5.3.

The tables give maximum circuit lengths, beyond which the ohmic resistance of the conductors will limit the magnitude of the short-circuit current to a level below that required to trip the circuit breaker (or to blow the fuse) protecting the circuit, with sufficient rapidity to ensure safety against indirect contact. The tables consider:

- The type of protection: circuit breakers or fuses, operating-current settings
- Cross-sectional area of phase conductors and protective conductors
- Type of earthing scheme
- Correction factor: **Fig. F40** indicates the correction factor to apply to the lengths given in tables **Fig. F25** to **Fig. F28**, when considering an IT system

Circuit	Conductor material	m = Sph/SPE (or PEN)			
		m = 1	m = 2	m = 3	m = 4
3 phases	Copper	0.86	0.57	0.43	0.34
	Aluminium	0.54	0.36	0.27	0.21
3ph + N or 1ph + N	Copper	0.50	0.33	0.25	0.20
	Aluminium	0.31	0.21	0.16	0.12

Fig. F40 Correction factor to apply to the lengths given in tables **Fig. F25** to **Fig. F28** for IT systems

F26

Example

A 3-phase 3-wire 230/400 V installation is IT-earthed.

One of its circuits is protected by a circuit breaker rated at 63 A, and consists of an aluminium-cored cable with 50 mm² phase conductors. The 25 mm² PE conductor is also aluminium. What is the maximum length of circuit, below which protection of persons against indirect-contact hazards is assured by the instantaneous magnetic tripping relay of the circuit breaker?

Fig. F26 indicates 603 meters, to which must be applied a correction factor of 0.36 (m = 2 for aluminium cable).

The maximum length is therefore 217 meters.

Maximum tripping times

Disconnecting times for IT system depends on how the different installation and substation earth electrodes are interconnected.

For final circuits (= circuits with a rated current not exceeding 63 A with one or more socket-outlets, and 32 A supplying only fixed connected current-using equipment), the maximum tripping time is the same as in TN system (see **Fig. F19**).

For the other circuits within the same group of interconnected exposed-conductive-parts, the maximum disconnecting time is 5s. This is because any double fault situation within this group will result in a short-circuit current as in TN system.

For final circuits (= circuits with a rated current not exceeding 63 A with one or more socket-outlets, and 32 A supplying only fixed connected current-using equipment) having their exposed-conductive-parts connected to an independent earth electrode electrically separated from the substation earth electrode, the maximum tripping time is given in **Fig. F13**. For the other circuits within the same group of non-interconnected exposed-conductive-parts, the maximum disconnecting time is 1s. This is because any double fault situation resulting from one insulation fault within this group and another insulation fault from another group will generate a fault current limited by the different earth electrode resistances as in TT system.

6 Implementation of IT system

6.4 Practical aspects

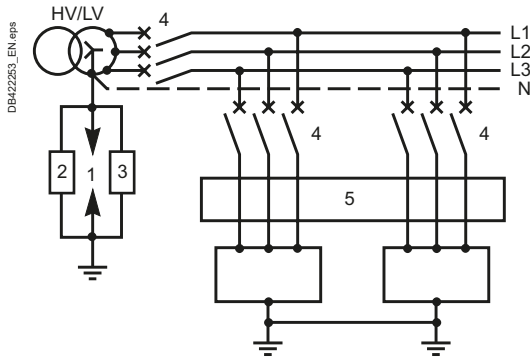


Fig. F41 Positions of essential functions in 3-phase 3-wire IT-earthed system

Minimum functions required	Components and devices	Examples
Protection against overvoltages at power frequency	1- Voltage limiter	Cardew C
Neutral earthing resistor (for impedance earthing variation)	2- Resistor	Impedance Zx
Overall earth-fault monitor with alarm for first fault condition	3- Permanent insulation monitor PIM with alarm feature	Vigilohm IM10 or IM400
Automatic fault clearance on second fault and protection of the neutral conductor against overcurrent	4- Four-pole circuit breakers (if the neutral is distributed all 4 poles trip)	Compact-circuit breakers or RCD-MS
Location of first fault	5- With device for fault-location on live system, or by successive opening of circuits	Vigilohm XGR+XRM or XD312 or XL308

Fig. F42 Essential functions in IT schemes and examples with Schneider Electric products

Principle of earth-fault monitoring

A generator of very low frequency a.c. current, or of d.c. current, (to reduce the effects of cable capacitance to negligible levels) applies a voltage between the neutral point of the supply transformer and earth. This voltage causes a small current to flow according to the insulation resistance to earth of the whole installation, plus that of any connected appliance.

Low-frequency instruments can be used on a.c. systems which generate transient d.c. components under fault conditions. Certain versions can distinguish between resistive and capacitive components of the leakage current.

Modern equipment allow the measurement of leakage-current evolution, so that prevention of a first fault can be achieved.

Examples of equipment

■ Manual fault-location (see Fig. F43)

The generator may be fixed (example: IM400) or portable (example: XGR) permitting the checking of dead circuits) and the receiver, together with the magnetic clamp-type pick-up sensor, are portable.

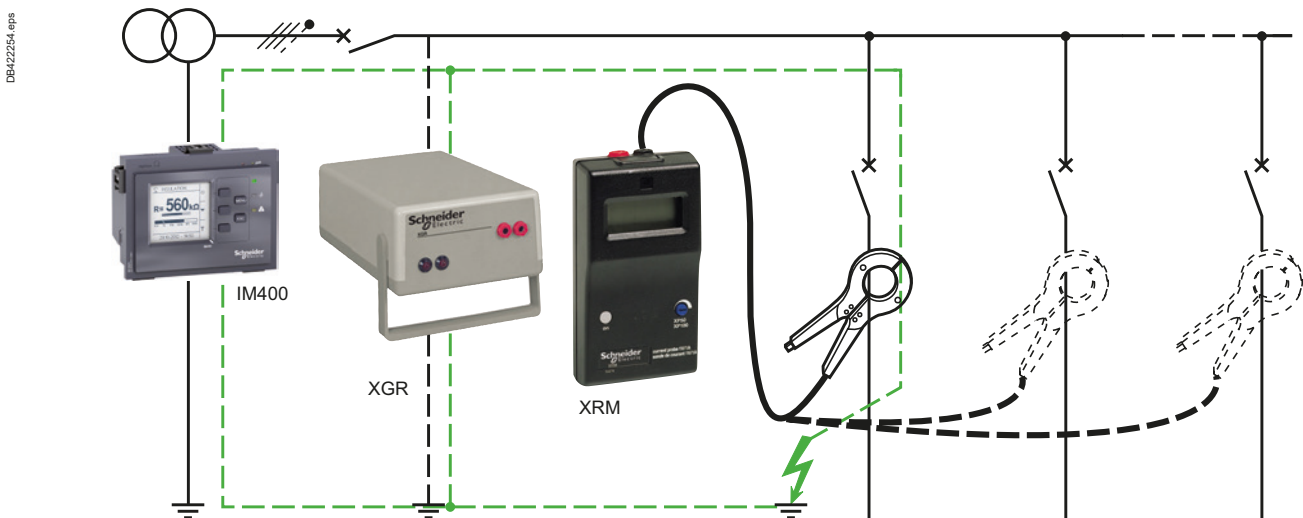


Fig. F43 Non-automatic (manual) fault location

6 Implementation of IT system

■ Fixed automatic fault location (see Fig. F44)

The PIM IM400, together with the fixed detectors XD301 or XD312 (each connected to a toroidal CT embracing the conductors of the circuit concerned) provide a system of automatic fault location on a live installation.

Moreover, the level of insulation is indicated for each monitored circuit, and two levels are checked: the first level warns of unusually low insulation resistance so that preventive measures may be taken, while the second level indicates a fault condition and gives an alarm.

Upstream supervision can centralize insulation & capacitance levels thanks to the IM400 embedded modbus communication.

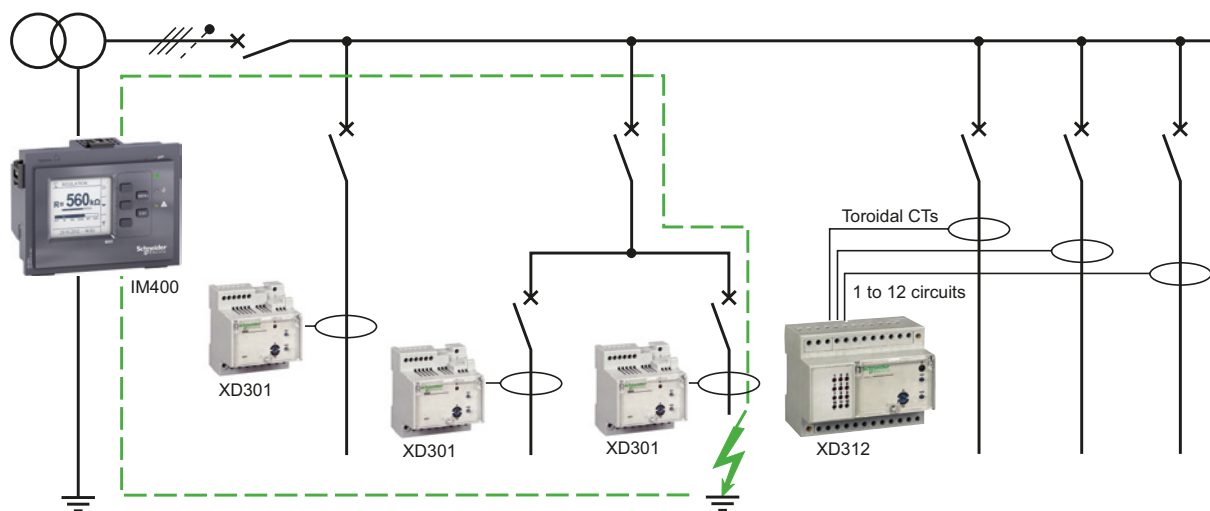


Fig. F44 Fixed automatic fault location

■ Automatic monitoring, logging, and fault location (see Fig. F45)

With Vigilohm system connected to a supervision system through Modbus RS485 communication, it is possible for a centralized supervision system to monitor insulation level and status at global level as well as for every feeder.

The central monitor XM300, together with the localization detectors XL308 and XL316, associated with toroidal CTs from several circuits, as shown in Fig. F45, provide the means for this automatic exploitation.

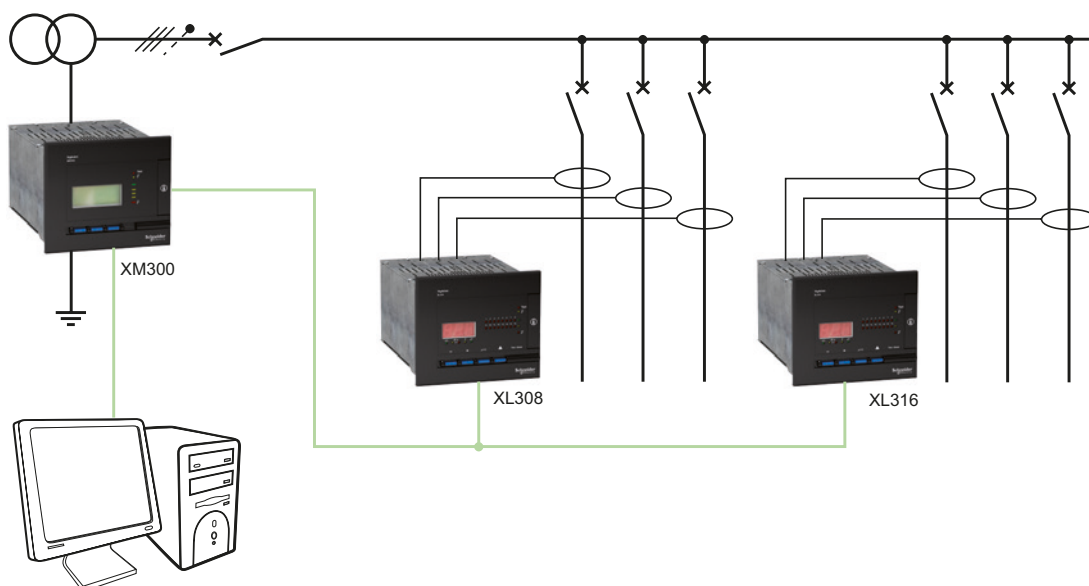


Fig. F45 Automatic fault location and insulation-resistance data logging

6 Implementation of IT system

Implementation of permanent insulation-monitoring (PIM) devices

Connection

The PIM device is normally connected between the neutral (or artificial neutral) point of the power-supply transformer and its earth electrode.

Supply

Power supply to the PIM device should be taken from a highly reliable source. In practice, this is generally directly from the installation being monitored, through overcurrent protective devices of suitable short-circuit current rating.

Level settings

Certain national standards recommend a first setting at 20% below the insulation level of the new installation. This value allows the detection of a reduction of the insulation quality, necessitating preventive maintenance measures in a situation of incipient failure.

The detection level for earth-fault alarm will be set at a much lower level.

By way of an example, the two levels might be:

- New installation insulation level: 100 k Ω
- Leakage current without danger: 300 mA (fire risk at $I > 300$ mA)
- Indication levels set by the consumer:
 - Threshold for preventive maintenance: $0.8 \times 100 = 80$ k Ω
 - Threshold for short-circuit alarm: 500 Ω

Notes:

- Following a long period of shutdown, during which the whole, or part of the installation remains de-energized, humidity can reduce the general level of insulation resistance.
- This situation, which is mainly due to leakage current over the damp surface of healthy insulation, does not constitute a fault condition, and will improve rapidly as the normal temperature rise of current-carrying conductors reduces the surface humidity.
- Some PIM device (IM20, IM400 & XM300) can measure separately the resistive and the capacitive current components of the leakage current to earth, thereby deriving the true insulation resistance from the total permanent leakage current.

7 Residual Current Devices (RCDs)

7.1 Description of RCDs

The essential features are shown schematically in Fig. F46.

A magnetic core encompasses all the current-carrying conductors of an electric circuit and the magnetic flux generated in the core will depend at every instant on the vectorial sum of the currents; the currents passing in one direction being considered as positive (I_1), while those passing in the opposite direction will be negative (I_2).

In a normally healthy circuit $\vec{I}_1 + \vec{I}_2 = 0$ and there will be no flux in the magnetic core, and zero e.m.f. in its coil.

An earth-fault current I_d will pass through the core to the fault, but will return to the source via the earth, or via protective conductors in a TN-earthed system.

The current balance in the conductors passing through the magnetic core therefore no longer exists, and the difference gives rise to a magnetic flux in the core.

The difference current is known as the "residual" current and the principle is referred to as the "residual current" principle.

F30

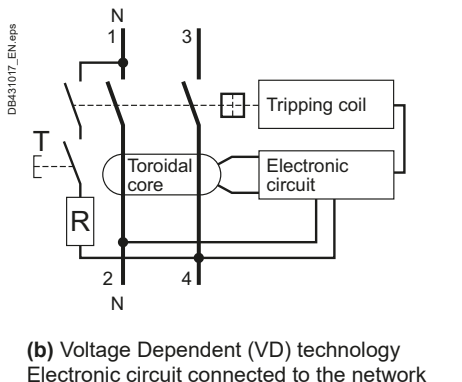
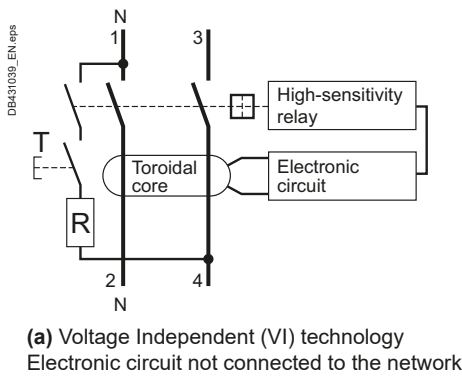


Fig. F47 The 2 technologies of RCDs

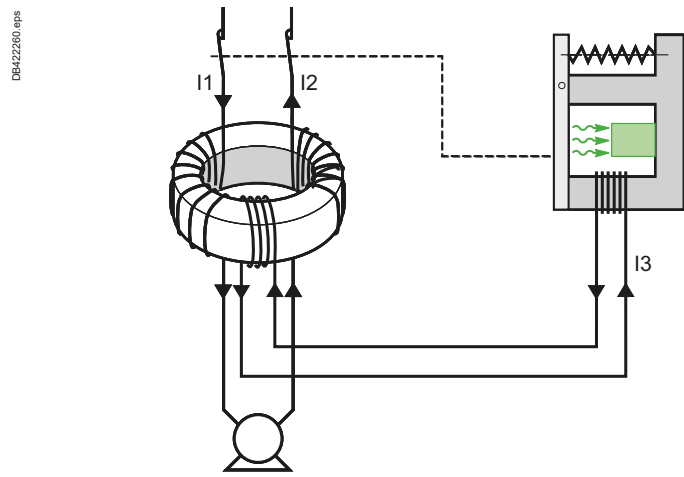


Fig. F46 Principle of RCD

In the **Voltage Independent (VI)** technology (Fig. F47a), the resultant alternating flux in the core induces an e.m.f. in its coil, so that a current I_3 flows in the tripping-device operating coil. If the residual current exceeds the value required to operate the tripping device either directly or via an electronic relay, then the associated circuit breaker will trip. The energy necessary to trip mechanism comes directly from residual current, independent of line voltage.

With this technology, whatever the line voltage is (i.e. even in case of neutral breakdown or voltage drop $< 50\text{ V}$), the RCD is able to trip in case the residual current exceeds the value required to operate.

With the **Voltage Dependent (VD)** technology (Fig. F47b), the summation current transformer measures residual current, an electronic circuit detects the tripping level and then sends an order to tripping unit to open the protected circuit. In this case, the power supply of electronic circuit and energy for tripping unit come from the line voltage.

With this technology, the RCD will be able to detect but not to trip if the line voltage is too low, because the electronic circuit and tripping units needs to be powered. The minimum supply line voltage is 50 V , in order to allow tripping.

7 Residual Current Devices (RCDs)

7.2 Form factors of RCDs

Residual current devices (RCD) are commonly incorporated in or associated with the following components:

- Industrial-type moulded-case circuit breakers (MCCB) and air circuit breakers (ACB) conforming to IEC 60947-2 and annex B or M
- Industrial type miniature circuit breakers (MCB) conforming to IEC 60947-2 and its annex B or M
- Household and similar uses miniature circuit breakers (MCB) complying with IEC 60898, IEC 61008, IEC 61009, IEC 62423
- Residual load switch conforming to particular national standards
- Relays with separate toroidal (ring-type) current transformers, conforming to IEC 60947-2 annex M

RCDs are mandatorily used at the origin of TT-earthed installations, where their ability to coordinate with other RCDs allows selective tripping, thereby ensuring the level of service continuity required.

Industrial type circuit breakers with integrated or adaptable RCD module (see Fig. F48)

Industrial circuit breakers with an integrated RCD are covered in IEC 60947-2 and its annex B



Fig. F48 Industrial-type CB with RCD module

Adaptable residual current circuit breakers, including DIN-rail mounted units (e.g. Compact or Acti 9), are available, to which may be associated an auxiliary RCD module (e.g. Vigi).

The ensemble provides a comprehensive range of protective functions (isolation, protection against short-circuit, overload, and earth-fault).

7 Residual Current Devices (RCDs)

Household and similar miniature circuit breakers with RCD (see Fig. F49)

Household or domestic circuit breakers with an integrated RCD are covered in IEC 60898, IEC 61008, IEC 61009 and IEC 62423

PB116746.eps



The incoming-supply circuit breaker can also have time-delayed characteristics and integrate a RCD (type S)

PB116747.eps



"Monobloc" iID residual current circuit breakers intended for protection of terminal socket-outlet circuits in domestic and tertiary sector applications

Fig. F49 Domestic residual current circuit breakers (RCCBs) for earth leakage protection

F32

RCDs with separate toroidal current transformer (see Fig. F50)

RCDs with separate toroidal current transformers are standardized in IEC 60947-2 annex M

RCDs with separate toroidal CTs can be used in association with circuit breakers

PB116748.eps



PB116749.eps



Fig. F50 RCDs with separate toroidal current transformers (Vigirex)

7 Residual Current Devices (RCDs)

7.3 Types of RCDs

The fault residual current could take various waveforms depending on the load characteristics. The following types of RCDs are defined in IEC 60755, for suitable protection of different forms of residual current:

Type AC

Type AC RCDs detect residual sinusoidal alternating currents. Type AC RCDs are suitable for general use and cover most of the applications in practice.

Type A

In addition to the detection characteristics of type AC RCDs, Type A RCDs detect pulsating DC residual current. Such waveforms can be caused by diode or thyristor rectifier circuit in electronic loads. Type A RCD are specifically intended to be used for single phase class 1 electronic loads.

Type F

Type F RCDs is a new RCD type recently introduced in IEC 62423 and in IEC60755. In addition to the detection characteristics of type A RCDs, type F RCDs are specially designed for circuit protection where single phase variable speed drives could be used. In these circuits, the waveform of residual current could be a composite of multi-frequencies including motor frequency, convertor switching frequency and line frequency. For the reason of energy efficiency, the use of frequency converters in certain loads (washing machine, air conditioner, ...) is increasing, and type F RCD will cover those new applications.

Type F also has enhanced disturbance withstand characteristics (non-tripping on surge current). They are capable of tripping even if a pure direct current of 10 mA is superimposed on a sinusoidal or pulsed DC differential current.

Type B

Type B RCDs can detect sinusoidal AC, pulsating DC, composite of multi-frequency as well as smooth DC residual currents. In addition, tripping conditions are defined with different frequencies from 50Hz to 1kHz. In an AC electrical distribution network, a pure DC residual current can be mainly generated from three-phase rectifying circuits, but also from some specific single phase rectifiers.

Type B RCD are intended to be used for loads with three-phase rectifier, such as variable speed drives, PV system, EV charging station and medical equipment.

Fig. F51 summarizes the definition of different types of RCD, with their main application and waveforms. It has to be noted that the different types of RCDs (AC, A, F and B) are nested one within the other like Russian dolls: type B, for example, also complies with the requirements of type F, type A and type AC.

DB431022_EN.eps





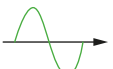
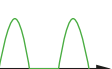

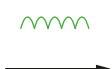
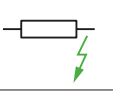
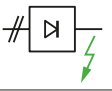
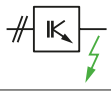
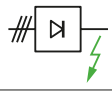
Type	AC 	A 	F 	B 
I fault				
Load	 linear	 single phase rectifier	 single phase frequency converter	 3 phase rectifier

Fig. F51 Different types of RCDs

Annex B of IEC 60755 gives, for different electronic load architectures, the possible load and residual current waveforms, and proposes the suitable types of RCD for each case. (see **Fig. F52**)

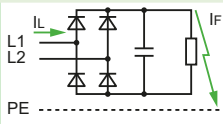


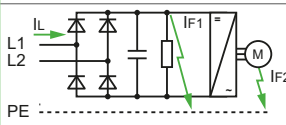
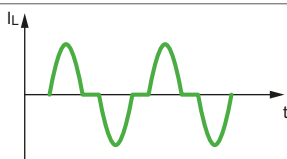
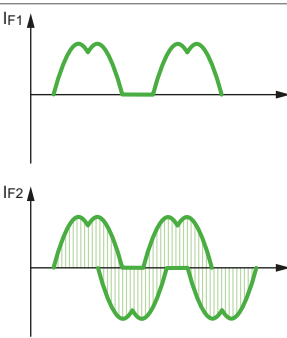
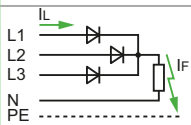
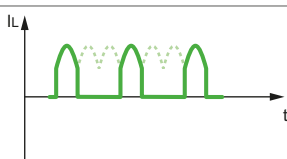
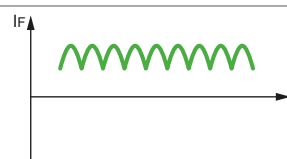
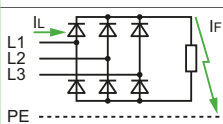
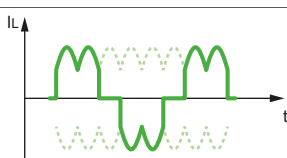
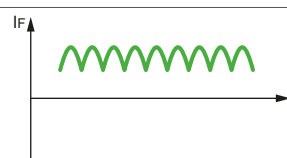
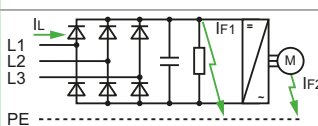
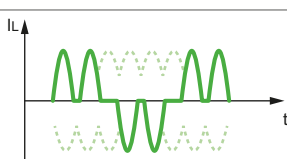
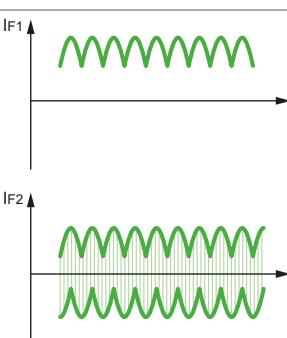
7 Residual Current Devices (RCDs)

F34

	Circuit diagram with fault location	Shape of line current I_L	Shape of earth fault current I_F	RCD tripping characteristic
1	Phase control 			AC, A, F, B
2	Burst control 			AC, A, F, B
3	Single-phase 			A, F, B
4	Two-pulse bridge 			A, F, B
5	Two-pulse bridge, half controlled 			A, F, B
6	Frequency inverter with two-pulse bridge 			F, B
7	Single-phase with smoothing 			B
8	Frequency inverter with two-pulse bridge and PFC 			B

Fig. F52 Possible fault currents in electronic loads and suitable RCD types - IEC 60755

7 Residual Current Devices (RCDs)

	Circuit diagram with fault location	Shape of line current I_L	Shape of earth fault current I_f	RCD tripping characteristic
9	Two-pulse bridge between phases 			B
10	Frequency inverter with two-pulse bridge between phases 			B
11	Three-phase star 			B
12	Six-pulse bridge 			B
13	Frequency inverter with six-pulse bridge 			B

F35

Fig. F52 Possible fault currents in electronic loads and suitable RCD types - IEC 60755

7 Residual Current Devices (RCDs)

F36

7.4 Sensitivity of RCDs to disturbances

In certain cases, aspects of the environment can disturb the correct operation of RCDs:

- **“nuisance” tripping:** Break in power supply without the situation being really hazardous. This type of tripping is often repetitive, causing major inconvenience and detrimental to the quality of the user’s electrical power supply.
- **non-tripping,** in the event of a hazard. Less perceptible than nuisance tripping, these malfunctions must still be examined carefully since they undermine user safety.

Main electrical disturbance types

Permanent earth leakage currents

Every LV installation has a permanent leakage current to earth, which is either due to:

- Unbalance of the intrinsic capacitance between live conductors and earth for three-phase circuits or
- Capacitance between live conductors and earth for single-phase circuits

The larger the installation the greater its capacitance with consequently increased leakage current.

The capacitive current to earth is sometimes increased significantly by filtering capacitors associated with electronic equipment (automation, IT and computer-based systems, etc.).

In the absence of more precise data, permanent leakage current in a given installation can be estimated from the following values, measured at 230 V 50 Hz:

- Single-phase or three-phase line: 1.5 mA /100m
- Heating floor: 1mA / kW
- Fax terminal, printer: 1 mA
- Microcomputer, workstation: 2 mA
- Copy machine: 1.5 mA

Since RCDs complying with IEC and many national standards may trip between $0.5 I_{\Delta n}$ and $I_{\Delta n}$, for residual currents higher than $0.5 I_{\Delta n}$ it is recommended to divide the installation by sub-division of circuits to avoid unwanted tripping.

For very particular cases, such as the extension, or partial renovation of extended IT-earthed installations, the manufacturers must be consulted.

High frequency components (harmonics, transients, etc.), are generated by computer equipment power supplies, converters, motors with speed regulators, fluorescent lighting systems and in the vicinity of high power switching devices and reactive energy compensation banks.

Part of these high frequency currents may flow to earth through parasitic capacitances. Although not hazardous for the user, these currents can still cause the nuisance tripping of differential devices.

SI type RCDs have a specific frequency response curve designed to prevent nuisance tripping when non-dangerous high frequency residual currents are present.

Energization

The initial energization of the capacitances mentioned above gives rise to high frequency transient currents of very short duration, similar to that shown in Fig. F53.

The sudden occurrence of a first-fault in an IT-earthed system also causes transient earth-leakage currents at high frequency, due to the sudden rise of the two healthy phases to phase/phase voltage above earth.

SI type RCDs present a small tripping delay, allowing to let pass this transient current without nuisance tripping.

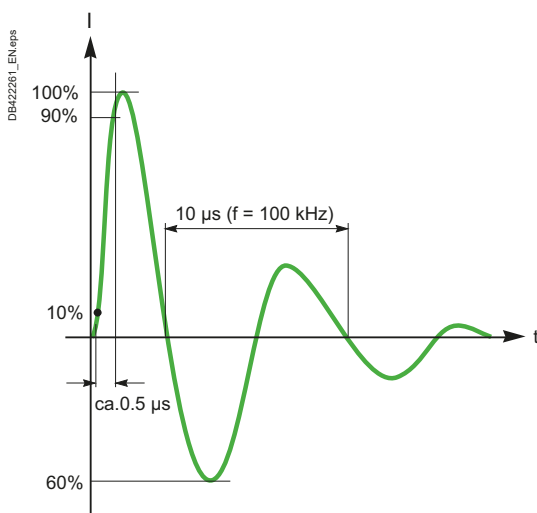


Fig. F53 Standardized 0.5 μs/100 KHz current transient wave

7 Residual Current Devices (RCDs)

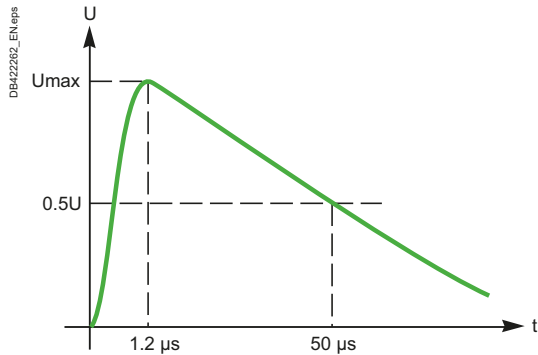


Fig. F54 Standardized 1.2/50 μs voltage transient wave

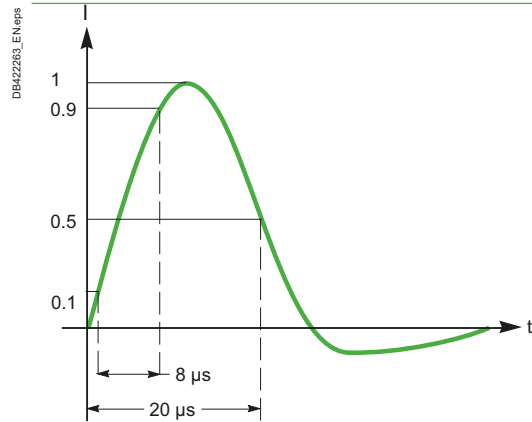


Fig. F55 Standardized current-impulse wave 8/20 μs

Common mode overvoltages

Electrical networks are subject to overvoltages due to lightning strikes or to abrupt changes of system operating conditions (faults, fuse operation, switching, etc.).

These sudden changes often cause large transient voltages and currents in inductive and capacitive circuits. Records have established that, on LV systems, overvoltages remain generally below 6 kV, and that they can be adequately represented by the conventional 1.2/50 μs impulse wave (see Fig. F54).

These overvoltages give rise to transient currents represented by a current impulse wave of the conventional 8/20 μs form, having a peak value of several tens of amperes (see Fig. F55).

The transient currents flow to earth via the capacitances of the installation.

SI type RCDs offer a high surge current capability and can withstand a 8/20μs current impulse higher than 3kA.

Main climatic disturbance types

Cold

In the cases of temperatures under - 5°C, very high sensitivity electromechanical relays in the RCD may be “welded” by the condensation – freezing action. Type “SI” devices can operate at temperatures down to - 25 °C.

Atmospheres with high concentrations of chemicals or dust

The special alloys used to make the RCDs can be notably damaged by corrosion. Dust can also block the movement of mechanical parts.

See the measures to be taken according to the levels of severity defined by standards in Fig. F56.

Regulations define the choice of earth leakage protection and its implementation.

The main reference text is IEC 60364-5-51:

- It gives a classification (AFx) for external influences in the presence of corrosive or polluting substances,
- It defines the choice of materials to be used according to extreme influences.

Presence of corrosive or polluting substances (IEC 60364-5-51)		Influence of the electrical network		Characteristics required for selection and erection of equipment
		Clean network	Disturbed network	
AF1	Negligible presence	Standard residual current protections Type AC	Super-immunized residual current protections Type A SI	Normal
AF2	Significant presence of atmospheric origin	Super-immunized residual current protections Type A SI		According to the nature of substances (for example, compliance to salt mist test according to IEC 60068-2-11)
AF3	Intermittent or accidental submission to corrosive or polluting chemical substances	Super-immunized residual current protections Type A SI + Appropriate additional protection (sealed cabinet or unit)		Protection against corrosion according to equipment specification
AF4	Continuous submission to corrosive or polluting chemical substances	Super-immunized residual current protections Type A SI + Appropriate additional protection (sealed cabinet or unit + overpressure)		Equipment specially designed according to the nature of substances

Examples of exposed sites	External influences
Iron and steel works.	Presence of sulfur, sulfur vapor, hydrogen sulfide.
Marinas, trading ports, boats, sea edges, naval shipyards.	Salt atmospheres, humid outside, low temperatures.
Swimming pools, hospitals, food & beverage.	Chlorinated compounds.
Petrochemicals.	Hydrogen, combustion gases, nitrogen oxides.
Breeding facilities, tips.	Hydrogen sulfide.

Fig. F56 External influence classification according to IEC 60364-5-51 standard

7 Residual Current Devices (RCDs)

Type SI RCDs immunity to nuisance tripping

Type SI RCDs have been designed to avoid nuisance tripping or non-tripping in case of polluted network, lightning effect, high frequency currents, RF waves, etc. **Fig. F57** below indicates the levels of tests undergone by this type of RCDs.

Disturbance type	Rated test wave	Immunity Acti 9 : ID-RCCB, DPN Vigi, Vigi iC60, Vigi C120, Vigi NG125 SI type
Continuous disturbances		
Harmonics	1 kHz	Earth leakage current = $8 \times I_{\Delta n}$
Transient disturbances		
Lightning induced overvoltage	1.2 / 50 μ s pulse (IEC/EN 61000-4-5)	4.5 kV between conductors 5.5 kV / earth
Lightning induced current	8 / 20 μ s pulse (IEC/EN 61008)	5 kA peak
Switching transient, indirect lightning currents	0.5 μ s / 100 kHz " ring wave " (IEC/EN 61008)	400 A peak
Downstream surge arrester operation, capacitance loading	10 ms pulse	500 A
Electromagnetic compatibility		
Inductive load switchings fluorescent lights, motors, etc.)	Repeated bursts (IEC 61000-4-4)	5 kV / 2.5 kHz 4 kV / 400 kHz
Fluorescent lights, thyristor controlled circuits, etc.	RF conducted waves (level 4 IEC 61000-4-6) (level 4 IEC 61000-4-16)	30 V (150 kHz to 230 MHz) 250 mA (15 kHz to 150 kHz)
RF waves (TV & radio, broadcast, telecommunications, etc.)	RF radiated waves 80 MHz to 1 GHz (IEC 61000-4-3)	30 V / m

Fig. F57 Immunity to nuisance tripping tests undergone by Schneider Electric RCDs

F38

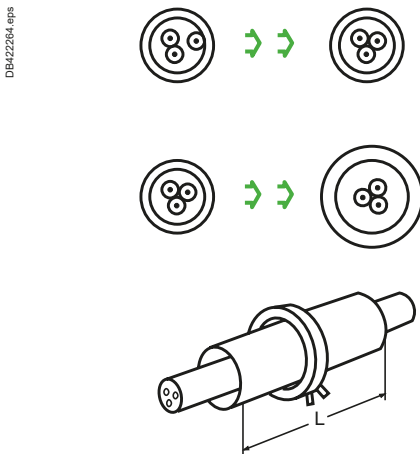
Recommendations concerning the installation of RCDs with separate toroidal current transformers

The detector of residual current is a closed magnetic circuit (usually circular) of very high magnetic permeability, on which is wound a coil of wire, the ensemble constituting a toroidal (or ring-type) current transformer.

Because of its high permeability, any small deviation from perfect symmetry of the conductors encompassed by the core, and the proximity of ferrous material (steel enclosure, chassis members, etc.) can affect the balance of magnetic forces sufficiently, at times of large load currents (motor-starting current, transformer energizing current surge, etc.) to cause unwanted tripping of the RCD.

Unless particular measures are taken, the ratio of operating current $I_{\Delta n}$ to maximum phase current I_{ph} (max.) is generally less than 1/1000.

This limit can be increased substantially (i.e. the response can be desensitized) by adopting the measures shown in **Fig. F58**, and summarized in **Fig. F59**.



L = twice the diameter of the magnetic ring core

Fig. F58 Means of reducing the ratio $I_{\Delta n}/I_{ph}$ (max.)

Measures	Diameter (mm)	Sensitivity diminution factor
Careful centralizing of cables through the ring core		3
Oversizing of the ring core	$\varnothing 50 \rightarrow \varnothing 100$	2
	$\varnothing 80 \rightarrow \varnothing 200$	2
	$\varnothing 120 \rightarrow \varnothing 300$	6
Use of a steel or soft-iron shielding sleeve	$\varnothing 50$	4
	$\varnothing 80$	3
	$\varnothing 120$	3
	$\varnothing 200$	2

These measures can be combined. By carefully centralizing the cables in a ring core of 200 mm diameter, where a 50 mm core would be large enough, and using a sleeve, the ratio 1/1000 could become 1/24000.

Fig. F59 Means of reducing the ratio $I_{\Delta n}/I_{ph}$ (max.)

7 Residual Current Devices (RCDs)

Choice of characteristics of a residual-current circuit breaker (RCCB - IEC 61008)

Rated current

The rated current of a RCCB is chosen according to the maximum sustained load current it will carry.

■ If the RCCB is connected in series with, and downstream of a circuit breaker, the rated current of both items will be the same, i.e. $I_n \geq I_{n1}$ (see (a) of Fig. F60)

■ If the RCCB is located upstream of a group of circuits, protected by circuit breakers, as shown in (b) of Fig. F60, then the RCCB rated current will be given by:

$$I_n \geq k_u \times k_s (I_{n1} + I_{n2} + I_{n3} + I_{n4})$$

Electrodynamics withstand requirements

Protection against short-circuits must be provided by an upstream SCPD (Short-Circuit Protective Device). Coordination between the RCCB and the SCPDs is necessary, and manufacturers generally provide tables associating RCCBs and circuit breakers or fuses.

DB422265 epsa

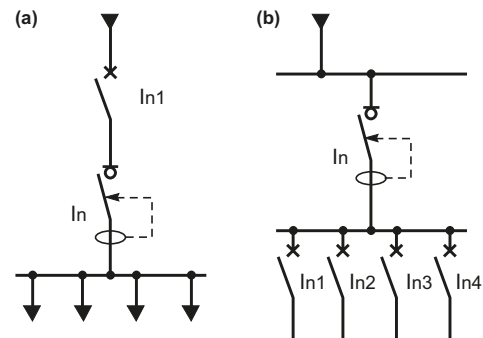


Fig. F60 Residual current circuit breakers (RCCBs)

7 Residual Current Devices (RCDs)

7.5 Coordination of residual current protective devices

Selectivity is achieved either by time-delay or by subdivision of circuits, which are then protected individually or by groups, or by a combination of both methods.

Such selectivity avoids the tripping of any RCD, other than that immediately upstream of a fault position:

■ With equipment currently available, selectivity is possible at three or four different levels of distribution:

- At the main general distribution board
- At local general distribution boards
- At sub-distribution boards
- At socket outlets for individual appliance protection

■ In general, at distribution boards (and sub-distribution boards, if existing) and on individual-appliance protection, devices for automatic disconnection in the event of an indirect-contact hazard occurring are installed together with additional protection against direct-contact hazards.

Selectivity between RCDs

The general specification for achieving total selectivity between two RCDs requires the two following conditions:

- The ratio between the rated residual operating currents must be > 3
- Time delaying the upstream RCD

Selectivity is achieved by exploiting the several levels of standardized sensitivity: 30 mA, 100 mA, 300 mA and 1 A and the corresponding tripping times, as shown in Fig. F61.

F40

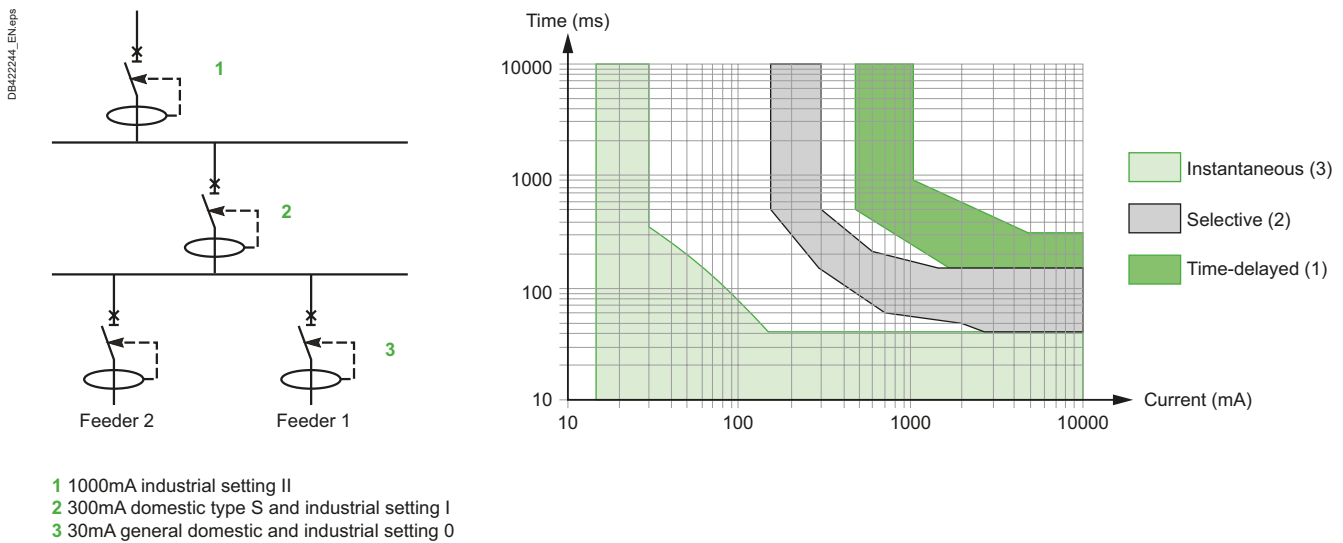


Fig. F61 Total selectivity at 3 levels

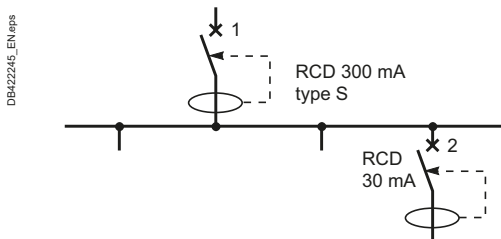


Fig. F62 Total selectivity at 2 levels

Selectivity at 2 levels (see Fig. F62)

Protection

- Level 1: RCD time-delayed setting I (for industrial device) or type S (for domestic device) for fault protection
- Level 2: RCD instantaneous, with high sensitivity on circuits supplying socket outlets or appliances at high risk (washing machines, etc.) See also **Chapter Q, Clause 3**.

Schneider Electric solutions

- Level 1: Compact or Acti 9 circuit breaker with adaptable RCD module (Vigicompact NSX160), setting I or S type
- Level 2: Circuit breaker with integrated RCD module (DPN Vigi) or adaptable RCD module (e.g. Vigi iC60) or Vigicompact NSX

Note: The setting of upstream RCCB must comply with selectivity rules and take into account all the downstream earth leakage currents.

7 Residual Current Devices (RCDs)

DB42246_EN.eps

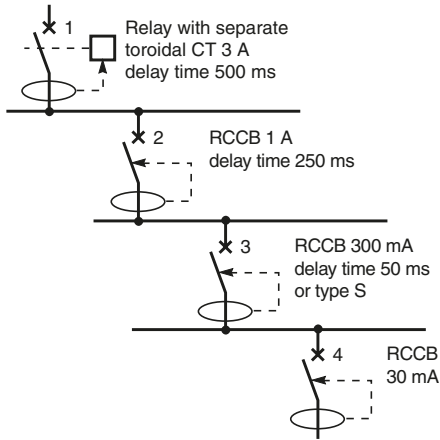


Fig. F63 Total selectivity at 3 or 4 levels

Selectivity at 3 or 4 levels (see Fig. F63)

Protection

- Level 1: RCD time-delayed (setting III)
- Level 2: RCD time-delayed (setting II)
- Level 3: RCD time-delayed (setting I) or type S
- Level 4: RCD instantaneous

Schneider Electric solutions

- Level 1: Circuit breaker associated with RCD and separate toroidal transformer (Vigirex RH)
- Level 2: Vigicomact NSX or Vigirex
- Level 3: Vigirex, Vigicomact NSX or Vigi iC60
- Level 4:
 - Vigicomact NSX or
 - Vigirex or
 - Acti 9 with integrated or adaptable RCD module: Vigi iC60 or DPN Vigi

Note: The setting of upstream RCCB must comply with selectivity rules and take into account all the downstream earth leakage currents

Specific case for the coordination with RCDs type B:

When there is a possible DC earth-leakage fault current, a RCD type B need to be used for protection against electric shock. In this case, the upstream RCD should not be blinded by the possible DC residual current and should provide its normal protection when any residual fault current happens in any other part of circuits.

For example, in the circuit of Fig. F64, the 30mA RCD type B at level 2 could have a maximum DC tripping threshold of $2 \cdot I_{\Delta n}$, according to RCD product standard IEC 62423. That means this 30mA RCD type B could let pass through almost 60mA DC residual current without tripping and the upstream RCD should not lose any of its performance with the presence of this high level of DC residual current. That's why it's often proposed to use a RCD type B at level 1 to avoid any blinding effect by DC current, as shown in Fig. F64.

However, Schneider Electric has proposed another possibility.

Some RCD type A in Schneider Electric are qualified to be not sensitive to DC residual current until 60mA. As shown in Fig. F65, they can be used upstream a 30 mA RCD type B without any blinding risk. Its type AC and type A protection behaviors are guaranteed even in the presence of a 60 mA smooth DC residual current.

These high security RCD type A include:

- Acti 9 RCD iID and Vigi 300 mA, 500 mA
- Vigi NG 125 300 mA, 500 mA, 1 A
- Vigi C120 300 mA, 500 mA, 1 A
- Compact NSXm, NSX 300 mA, and up

DB431019_EN.eps

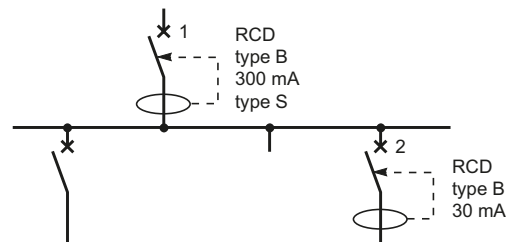


Fig. F64 Coordination between RCDs type B

DB431020_EN.eps

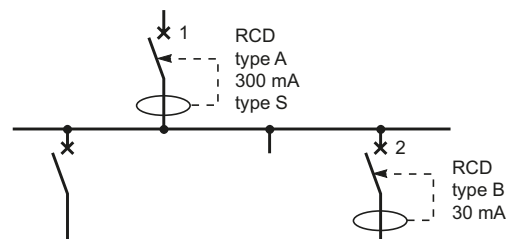


Fig. F65 Coordination between RCD type A and RCD type B

7 Residual Current Devices (RCDs)

Example of installation with selectivity at 2 or 3 levels (Fig. F66)

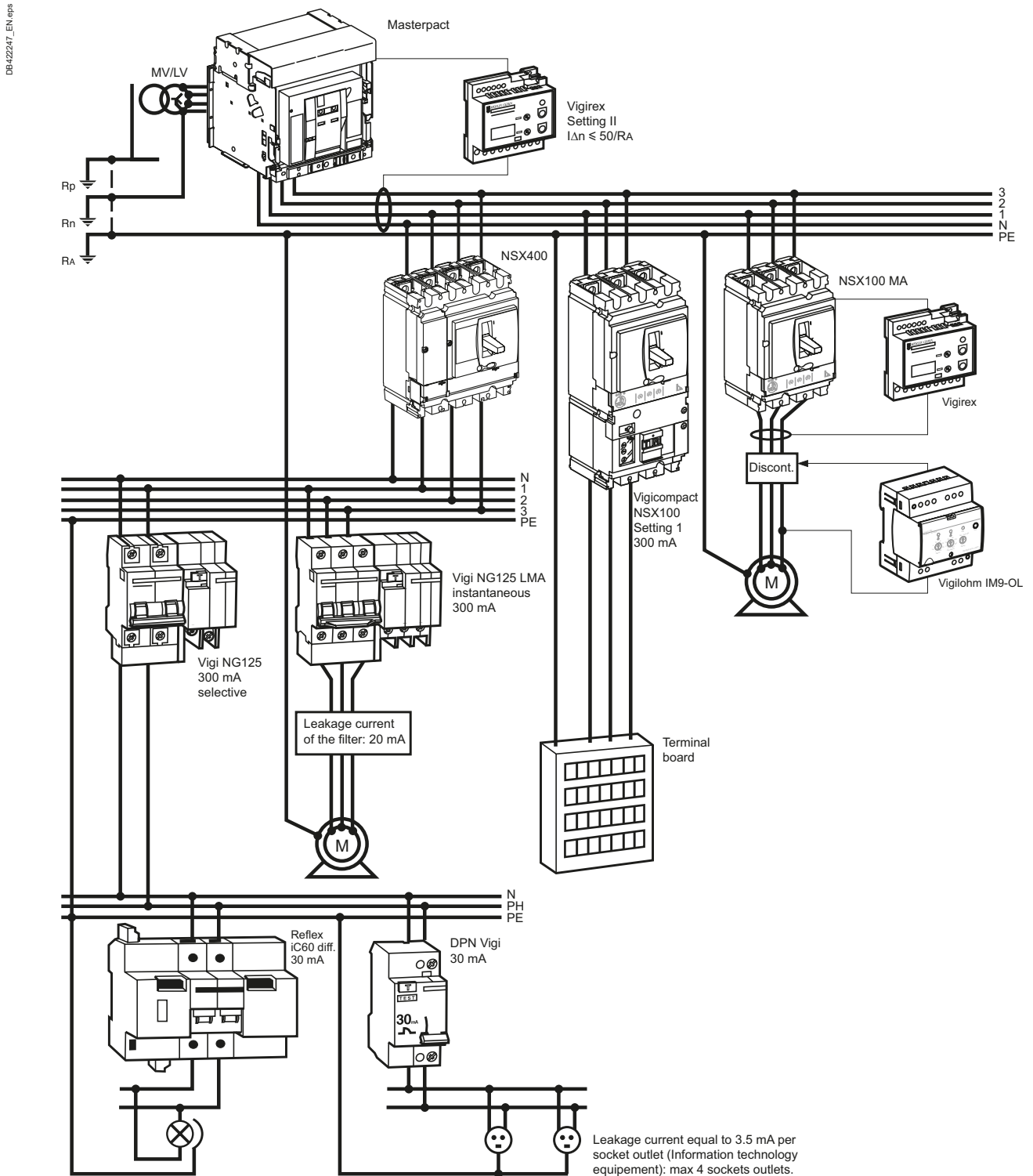


Fig. F66 Example of installation with selectivity at 2 or 3 levels

8 Other protective measures

Extra-low voltage is used where the risks are great: swimming pools, wandering-lead hand lamps, and other portable appliances for outdoor use, etc.

8.1 Extra Low Voltage (ELV)

Use of SELV (Safety Extra-Low Voltage)

Safety by extra low voltage SELV is used in situations where the operation of electrical equipment presents a serious hazard (swimming pools, amusement parks, etc.). This measure depends on supplying power at extra-low voltage from the secondary windings of isolating transformers especially designed according to national or to international (IEC 60742) standard. The impulse withstand level of insulation between the primary and secondary windings is very high, and/or an earthed metal screen is sometimes incorporated between the windings. The secondary voltage never exceeds 50 V rms.

Three conditions of exploitation must be respected in order to provide satisfactory fault protection:

- No live conductor at SELV must be connected to earth
- Exposed-conductive-parts of SELV supplied equipment must not be connected to earth, to other exposed conductive parts, or to extraneous-conductive-parts
- All live parts of SELV circuits and of other circuits of higher voltage must be separated by a distance at least equal to that between the primary and secondary windings of a safety isolating transformer.

These measures require that:

- SELV circuits must use conduits exclusively provided for them, unless cables which are insulated for the highest voltage of the other circuits are used for the SELV circuits
- Socket outlets for the SELV system must not have an earth-pin contact. The SELV circuit plugs and sockets must be special, so that inadvertent connection to a different voltage level is not possible.

Note: In normal conditions, when the SELV voltage is less than 25 V, there is no need to provide protection against direct contact hazards. Particular requirements are indicated in Chapter Q, clause 3: «Recommendations applicable to special installations and locations».

Use of PELV (Protection by Extra Low Voltage) (see Fig. F67)

This system is for general use where low voltage is required, or preferred for safety reasons, other than in the high-risk locations noted above. The conception is similar to that of the SELV system, but the secondary circuit may be earthed at one point.

IEC 60364-4-41 defines precisely the significance of the reference PELV. Basic protection is generally necessary, except when the equipment is in the zone of equipotential bonding, and the nominal voltage does not exceed 25 V rms, and the equipment is used in normally dry locations only, and large-area contact with the human body is not expected. In all other cases, 12 V rms is the maximum permitted voltage, where no basic protection is provided.

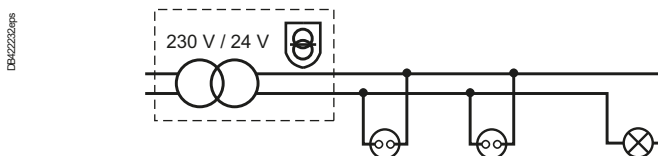


Fig. F67 Low-voltage supplies from a safety isolating transformer

FELV system (Functional Extra-Low Voltage)

Where, for functional reasons, a voltage of 50 V or less is used, but not all the requirements relating to SELV or PELV are fulfilled, appropriate measures described in IEC 60364-4-41 must be taken to ensure both basic and fault protection, according to the location and use of these circuits.

Note: Such conditions may, for example, be encountered when the circuit contains equipment (such as transformers, relays, remote-control switches, contactors) insufficiently insulated with respect to circuits at higher voltages.

8 Other protective measures

8.2 The electrical separation of circuits (see Fig. F68)

The electrical separation of circuits is suitable for relatively short cable lengths and high levels of insulation resistance. It is preferably used for an individual appliance

DB4422233 eps

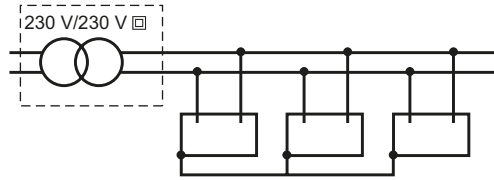


Fig. F68 Safety supply from a class II separation transformer

The principle of the electrical separation of circuits (generally single-phase circuits) for safety purposes is based on the following rationale.

The two conductors from the unearthed single-phase secondary winding of a separation transformer are insulated from earth.

If a direct contact is made with one conductor, a very small current only will flow into the person making contact, through the earth and back to the other conductor, via the inherent capacitance of that conductor with respect to earth. Since the conductor capacitance to earth is very small, the current is generally below the level of perception. As the length of circuit cable increases, the direct contact current will progressively increase to a point where a dangerous electric shock will be experienced.

Even if a short length of cable precludes any danger from capacitive current, a low value of insulation resistance with respect to earth can result in danger, since the current path is then via the person making contact, through the earth and back to the other conductor through the low conductor-to-earth insulation resistance.

For these reasons, relatively short lengths of well insulated cables are essential in separation systems.

Transformers are specially designed for this duty, with a high degree of insulation between primary and secondary windings, or with equivalent protection, such as an earthed metal screen between the windings. Construction of the transformer is to class II insulation standards.

As indicated before, successful exploitation of the principle requires that:

- No conductor or exposed conductive part of the secondary circuit must be connected to earth,
- The length of secondary cabling must be limited to avoid large capacitance values ^[1],
- A high insulation-resistance value must be maintained for the cabling and appliances.

These conditions generally limit the application of this safety measure to an individual appliance.

In the case where several appliances are supplied from a separation transformer, it is necessary to observe the following requirements:

- The exposed conductive parts of all appliances must be connected together by an insulated protective conductor, but not connected to earth,
- The socket outlets must be provided with an earth-pin connection. The earth-pin connection is used in this case only to ensure the interconnection (bonding) of all exposed conductive parts.

In the case of a second fault, overcurrent protection must provide automatic disconnection in the same conditions as those required for an IT system of power system earthing.

[1] It is recommended in IEC 364-4-41 that the product of the nominal voltage of the circuit in volts and length in metres of the wiring system should not exceed 100000, and that the length of the wiring system should not exceed 500 m.

8 Other protective measures

Class II equipment symbol:



8.3 Class II equipment

These appliances are also referred to as having “double insulation” since in class II appliances a supplementary insulation is added to the basic insulation (see Fig. F69).

No conductive parts of a class II appliance must be connected to a protective conductor:

- Most portable or semi-fixed equipment, certain lamps, and some types of transformer are designed to have double insulation. It is important to take particular care in the exploitation of class II equipment and to verify regularly and often that the class II standard is maintained (no broken outer envelope, etc.). Electronic devices, radio and television sets have safety levels equivalent to class II, but are not formally class II appliances

- Supplementary insulation in an electrical installation: IEC 60364-4-41 (Sub-clause 413-2) and some national standards such as NF C 15-100 (France) describe in more detail the necessary measures to achieve the supplementary insulation during installation work.

DB422234_EN.eps

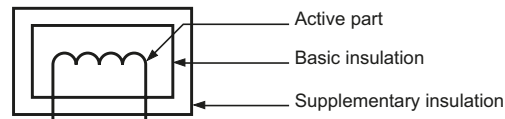


Fig. F69 Principle of class II insulation level (IEC 60364-4-41 sub-clause 412)

F45

A simple example is that of drawing a cable into a PVC conduit. Methods are also described for distribution switchboards.

- For ASSEMBLIES, IEC 61439-1 describes a set of requirements, for what is referred to as “total insulation”, equivalent to class II equipment
- Some cables are recognised as being equivalent to class II by many national standards.

In principle, safety by placing simultaneously-accessible conductive parts out-of-reach, or by interposing obstacles, requires also a non-conducting floor, and so is not an easily applied principle

8.4 Out-of-arm’s reach or interposition of obstacles

By these means, the probability of touching a live exposed-conductive-part, while at the same time touching an extraneous-conductive-part at earth potential, is extremely low (see Fig. F70). In practice, this measure can only be applied in a dry location, and is implemented according to the following conditions:

- The floor and the wall of the chamber must be non-conducting, i.e. the resistance to earth at any point must be:

- > 50 kΩ (installation voltage ≤ 500 V)
- > 100 kΩ (500 V < installation voltage ≤ 1000 V)

Resistance is measured by means of “MEGGER” type instruments (hand-operated generator or battery-operated electronic model) between an electrode placed on the floor or against the wall, and earth (i.e. the nearest protective earth conductor). The electrode contact area pressure must be evidently be the same for all tests.

Different instruments suppliers provide electrodes specific to their own product, so that care should be taken to ensure that the electrodes used are those supplied with the instrument.

- The placing of equipment and obstacles must be such that simultaneous contact with two exposed-conductive-parts or with an exposed conductive-part and an extraneous-conductive-part by an individual person is not possible.

- No exposed protective conductor must be introduced into the chamber concerned.

- Entrances to the chamber must be arranged so that persons entering are not at risk, e.g. a person standing on a conducting floor outside the chamber must not be able to reach through the doorway to touch an exposed-conductive-part, such as a lighting switch mounted in an industrial-type cast-iron conduit box, for example.

8 Other protective measures

DB42235_EN.eps

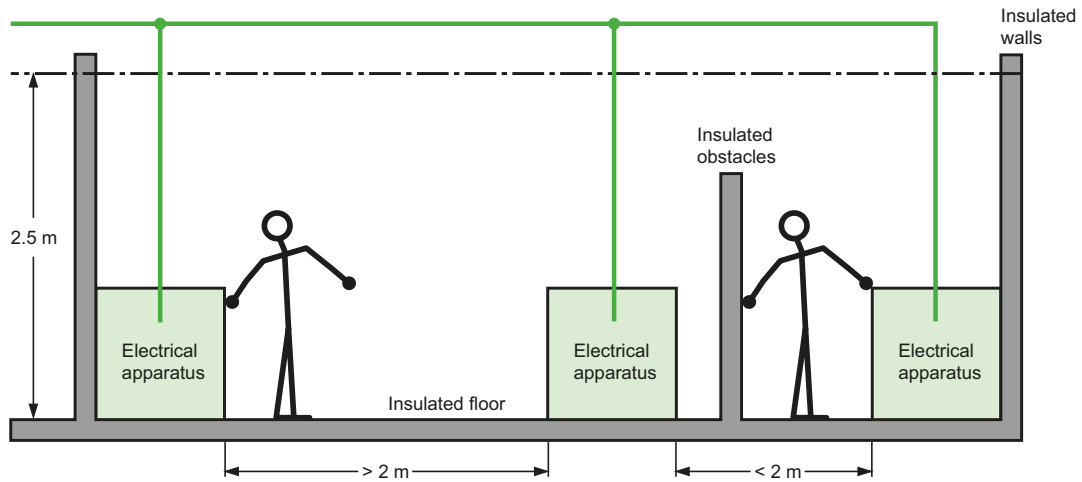


Fig. F70 Protection by out-of arm's reach arrangements and the interposition of non-conducting obstacles

F46

Earth-free equipotential chambers

Earth-free equipotential chambers are associated with particular installations (laboratories, etc.) and give rise to a number of practical installation difficulties

In this scheme, all exposed-conductive-parts, including the floor [1] are bonded by suitably large conductors, such that no significant difference of potential can exist between any two points. A failure of insulation between a live conductor and the metal envelope of an appliance will result in the whole "cage" being raised to phase-to-earth voltage, but no fault current will flow. In such conditions, a person entering the chamber would be at risk (since he/she would be stepping on to a live floor).

Suitable precautions must be taken to protect personnel from this danger (e.g. non-conducting floor at entrances, etc.). Special protective devices are also necessary to detect insulation failure, in the absence of significant fault current.

DB42236_EN.eps

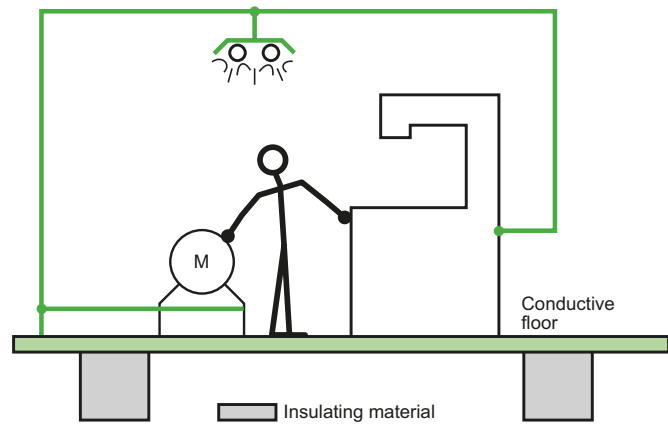


Fig. F71 Equipotential bonding of all exposed-conductive-parts simultaneously accessible

[1] Extraneous conductive parts entering (or leaving) the equipotential space (such as water pipes, etc.) must be encased in suitable insulating material and excluded from the equipotential network, since such parts are likely to be bonded to protective (earthed) conductors elsewhere in the installation.

9 Protection against electrical fire risks

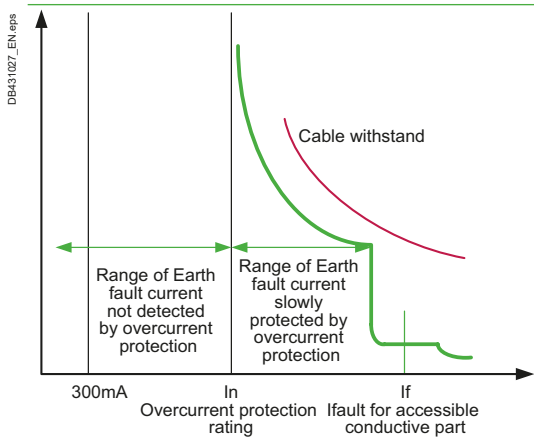


Fig. F72 Overcurrent protection curve and earth fault potential current

9.1 Fires of electrical origin

In Europe 2.000.000 fires are reported each year, which represent more than 4000 deaths, and 70000 people hospitalized due to severe injuries. On average, 90% of fires in EU happen in buildings (www.firesafeurope.eu).

Electricity is a very regularly identified cause of domestic fires. In homes, 280000 electrical fires occur each year (www.promotelec.com).

Depending on the country and the investigation methods, but also depending on the means of identification, the proportions of electrical fires are:

- 13 % in the United States (www.nfpa.org);
- 25 % in France (www.promotelec.com)
- 33 % in Germany (www.ifs-kiel.de);
- 40 % in Norway (www.sintef.no).

Electrical fires in low voltage installation may be caused by

- Overcurrents (overloads and short circuits): see **chapter G**
- earth faults: see §9.2,
- electric arcs in cables and connections: see §9.3.
- or overvoltages (lightning ...) see **chapter J**,

Note: Electric arcs in assembly are addressed in **chapter E**

RCDs are very effective devices to provide protection against fire risk due to insulation fault because they can detect leakage currents (ex : 300 mA) which are too low for the other protections, but sufficient to cause a fire.

9.2 Protection against fire due to earth faults

The great majority of electrical short-circuit in low voltage installation are line to earth insulation failure.

The protective measures against electric shock presented in previous section of this chapter will ensure automatic disconnection of the supply in case of fault between a line conductor and accessible conductive part that could lead to dangerous touch voltages.

But fault between a line conductor and earth with lower amplitude than cable overcurrent protection threshold (and no risk of "indirect contact") may also happen (see Fig. F72).

9.2.1 Protection with RCDs

An insulation failure between line conductor and earth in dusty and humid environment for instance can lead to an arc fault of low intensity according to line conductor withstand, but high enough to start a fire. Some tests have shown that even a fault current as low as 300 mA can induce a real risk of fire (see Fig. F73)

This type of fault current is too low to be detected by the overcurrent protection.

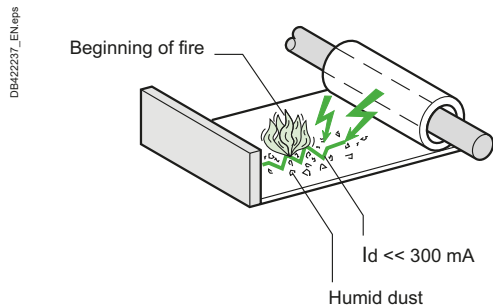
For TT, IT and TN-S systems the use of 300 mA sensitivity RCDs provides a good protection against fire risk due to this type of fault. (see Fig. F74)

The IEC 60364-4-42:2010 (clause 422.3.9) makes it mandatory to install RCDs of sensitivity ≤ 300 mA in high fire-risk locations (locations with risks of fire due to the nature of processed or stored materials - BE2 condition described in Table 51A of IEC 60364-5-51:2005). TN-C arrangement is also excluded and TN-S must be adopted.

In locations where RCD are not mandatory as per the IEC, it is still strongly recommended that you consider the use of RCDs, bearing in mind the potential consequences of fire.

See section F7 for the selection of RCDs.

Another solution is to use ground fault protection (see below) but the range of fault current detected will be reduced.



Some tests have shown that a very low leakage current (a few mA) can evolve and, from 300 mA induce a fire in humid and dusty environment.

Fig. F73 Origin of fires in building

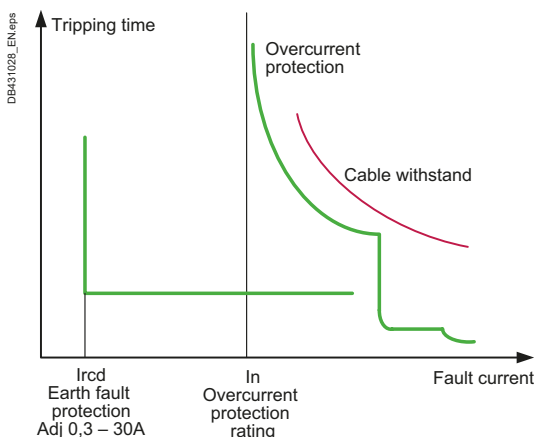


Fig. F74 Example of tripping curve of earth leakage protection

9 Protection against electrical fire risks

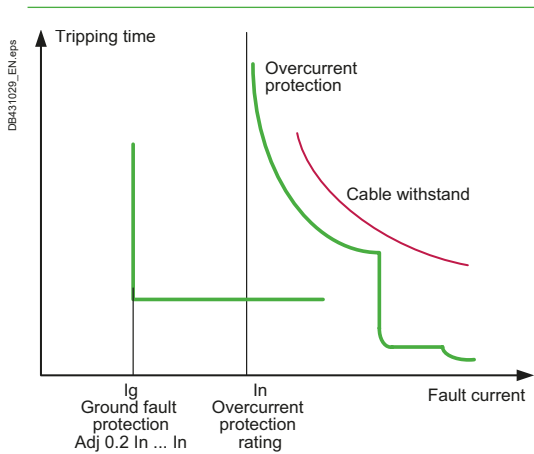


Fig. F75 Example of tripping curve of RS type ground fault protection

9.2.2 Protection with “Ground fault protection”

In TN-C system, RCD protection cannot be used, as the measurement of earth fault current by a sensor around line conductors and PEN will lead to permanent wrong measurement and unwanted trip. But a protection less sensitive than RCD but more sensitive than conductors’ overcurrent protection can be proposed. In North America this protection is commonly used and known as “Ground Fault Protection”.

Different types of ground fault protections (GFP) (see Fig. F77)

Three types of GFP may be used, depending on the measuring device installed:

■ “Residual Sensing” RS

The “insulation fault” current is calculated using the vectorial sum of currents of current transformers secondaries. The current transformer on the neutral conductor is often outside the circuit breaker.

■ “Source Ground Return” SGR

The “insulation fault current” is measured in the neutral – earth link of the LV transformer. The current transformer is outside the circuit breaker.

■ “Zero Sequence” ZS (Equivalent to IEC RCD in principle)

The “insulation fault” is directly measured at the secondary of the current transformer using the sum of currents in live conductors. This type of GFP is only used with low fault current values.

Ground fault protection can be included in the circuit breaker (see Fig. F76) or performed by a standalone relay. In all cases the device operated by the GFP shall have the breaking capacity of the maximum fault current at the point of installation, alone or in coordination with another overcurrent protective device.



Fig. F76 Example of Compact NSX630 with integrated Residual sensing ground fault protection Micrologic 6.3E

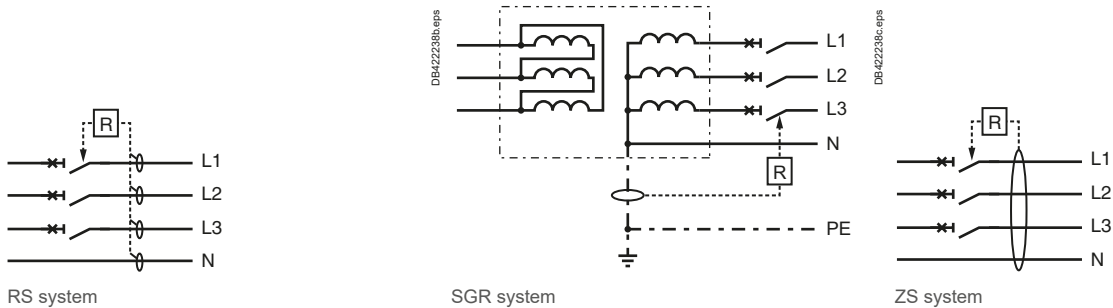


Fig. F77 Different types of ground fault protections

9 Protection against electrical fire risks

PB119910.eps



Fig. F78 Example of 250 A MCCB with earth leakage measurement and alarming (Compact NSX Micrologic Vigi 4.3)

9.2.3 Earth fault monitoring

Increasing the sensitivity of protection system will reduce the risk of fire but can also increase the risk of unexpected tripping on disturbance that are not real fault. (See section 7 for RCD sensitivity to disturbance for instance). Where balance between sensitivity and continuity of service is challenging, the monitoring of earth fault with no automatic disconnection brings also benefits.

Earth current monitoring and alarming allow:

- Early detection of deterioration of insulation
- Abnormal leakage currents
- Detection of neutral to earth unwanted contact in other place than the dedicated earthing link

PB119911.eps



Fig. F79 Example of external earth leakage monitoring relay

9 Protection against electrical fire risks

9.3 Protection against arc faults in cables and connections

9.3.1 Origin of arc faults in cables and connections

When a cable is locally damaged or an electrical connection comes loose, there are two main types of arc faults which initiate a fire:

■ Series Arc fault (see Fig. F84):

This phenomenon results from an arc between two parts of the same conductor (see Fig. F80).

Whenever a conductor is damaged or a connection is not properly tightened, a localized hot spot occurs which carbonizes the insulating materials in the vicinity of that conductor.

Carbon being a conductive material, it enables flow of the current which becomes excessive at various points.

Since the carbon is deposited in a non-homogeneous manner, the currents which pass through it generate electric arcs to facilitate their paths. Then each arc amplifies carbonization of the insulating materials, a reaction thus occurs which is maintained until the quantity of carbon is high enough for an arc to inflame it spontaneously (see Fig. F82).

■ Parallel arc fault (Resistive short circuit) (see Fig. F83):

This phenomenon happens between two different conductors (see Fig. F81).

Whenever the insulating materials between two live conductors are damaged, a significant current can be established between the two conductors, but it is too weak to be considered as a short circuit by a circuit breaker, and is undetectable by residual current protective devices as this current does not go to earth.

When passing through these insulating materials, these leakage currents optimize their paths by generating arcs which gradually transform the insulating materials into carbon.

DB422949a_EN.eps



Fig. F80 Serial Arc

F50

DB422949b_EN.eps



Fig. F81 Parallel arc fault

DB431031_EN.eps

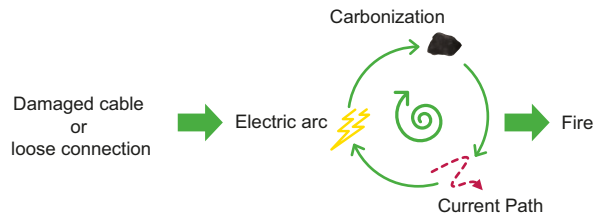


Fig. F82 Arc fault generation

PB116752.eps

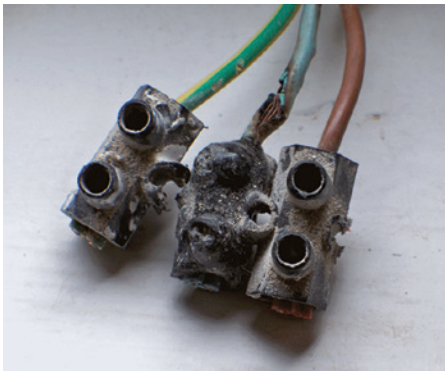


Fig. F84 Example of a carbonized connection

PB116753.eps

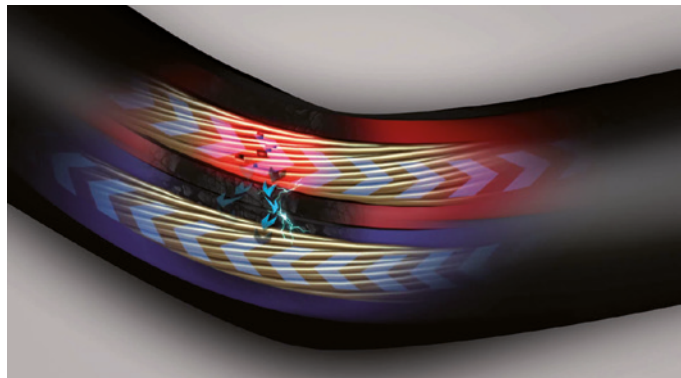
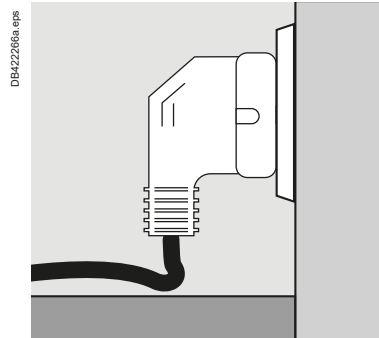


Fig. F83 Illustration of a resistive short circuit

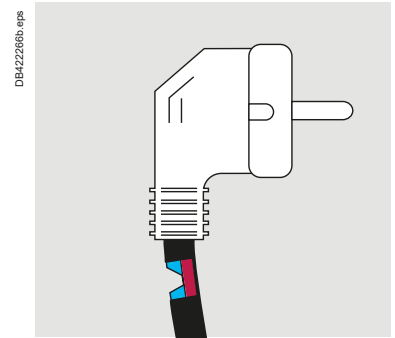
9 Protection against electrical fire risks

The common feature of these phenomena is ignition of the fire by arcs that is why detection of the presence of arcs is one way to prevent them from turning into a disaster.

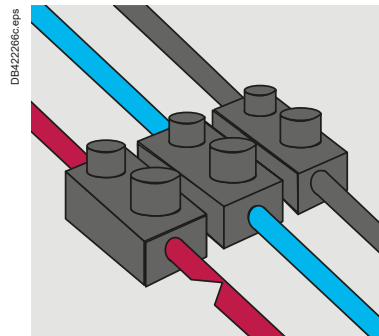
These phenomena can occur in the following situations (see Fig. F85):



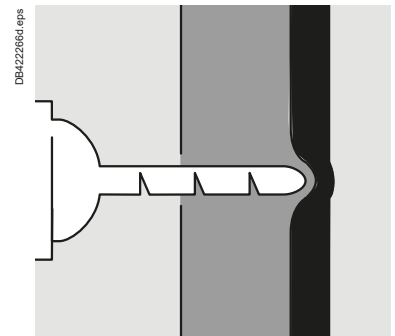
Power supply cord subjected to excessive forces (by furniture or a position)



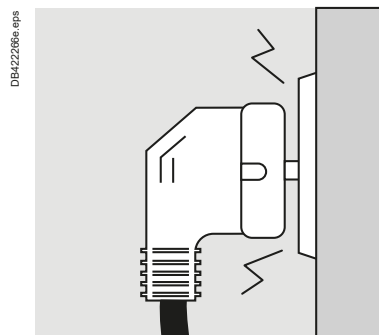
Power supply cord defective following inappropriate or excessively numerous operations



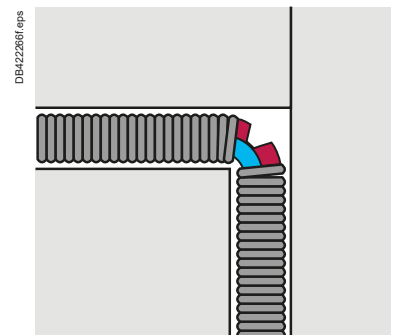
Cables weakened at connection



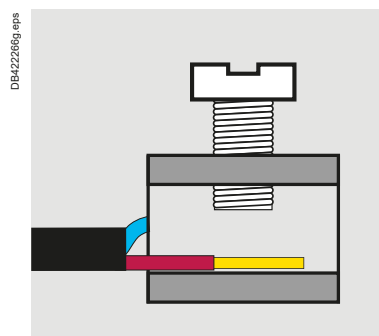
Accidental damage to a cable



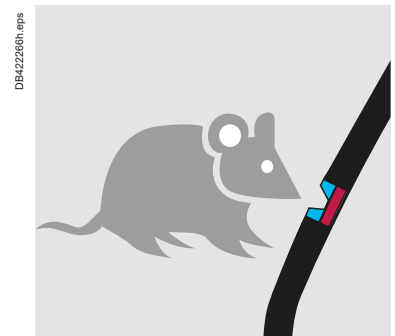
Power sockets in poor condition



Ageing of cable protective devices



Loose connections



Cables damaged by their environment UV, vibrations, moisture, rodents

Fig. F85 Situation increasing risks of fire

9 Protection against electrical fire risks

9.3.2 Arc Faults Detection Devices

How does it work?

The arc fault detection device technology makes it possible to detect dangerous arcs and thus protect installations.

Such devices have been deployed successfully in the United States since the early 2000s, and their installation is required by the National Electric Code.

Since 2013, the IEC 62606 international standard defines Arc Fault Detection Devices (AFDDs) which detect the presence of dangerous electric arcs and cut off the circuit's power supply to prevent initiating the first flame.

Speed is of the essence as an electrical arc can degrade in a flash (literally), igniting any nearby inflammable material and causing a fire. According to IEC 62606, arc fault detection devices shall react very fast in case of arc faults and isolates the circuit within limited time (see Fig. F86). These dangerous electric arcs are not detected by residual current devices nor by circuit breakers or fuses.

F52

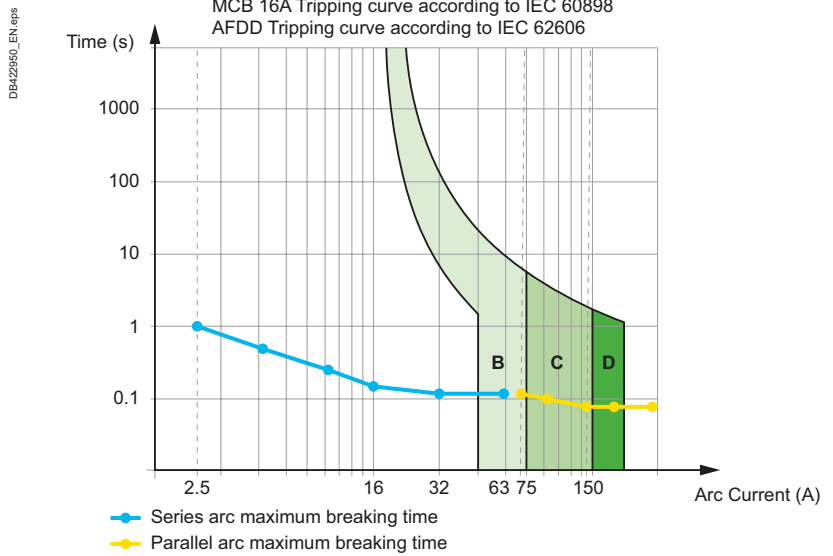


Fig. F86 MCB vs AFDD tripping curve

The arc fault detection device monitors in real time numerous electrical parameters of the circuit that it protects (see Fig. F87), in order to detect information characteristic of the presence of dangerous electric arcs (see Fig. F88). For example:

- The current of the arc (a series arc is dangerous as soon as its value equals or exceeds 2.5 Amps).
- The duration of the appearance of the arc (very short durations, for example, are characteristic of the normal operation of a switch).
- The irregularity of the arc (the arcs of brushed motors, for example, are fairly regular and as such should not be considered dangerous).
- The distortion of the current signal (sine) at the time of its zero crossing is characteristic of the presence of an electric arc: the current flows only after the appearance of an arc which needs a minimum voltage to be created (see Fig. F89).
- The presence of disturbances at varying levels of different high frequencies is characteristic of the passage of a current through heterogeneous materials (such as cable insulation).

9 Protection against electrical fire risks

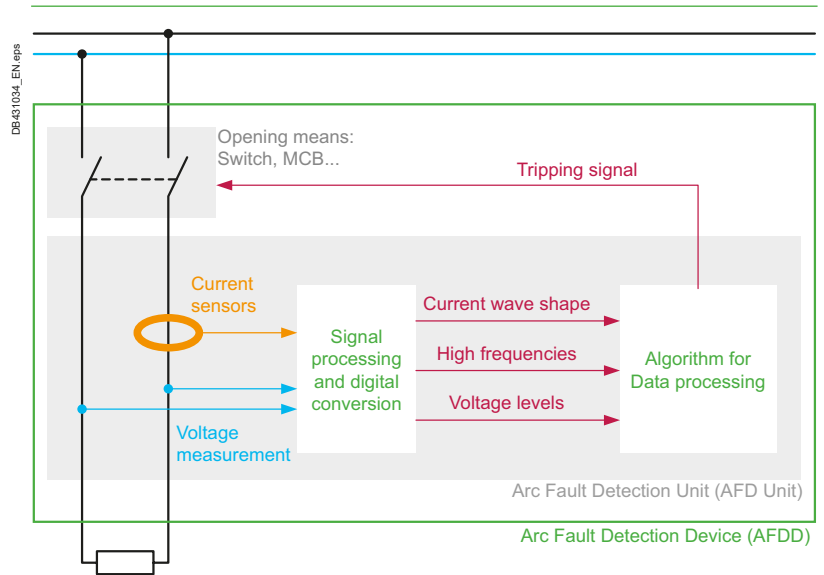


Fig. F87 General principle of Schneider Electric arc fault detection devices

F53

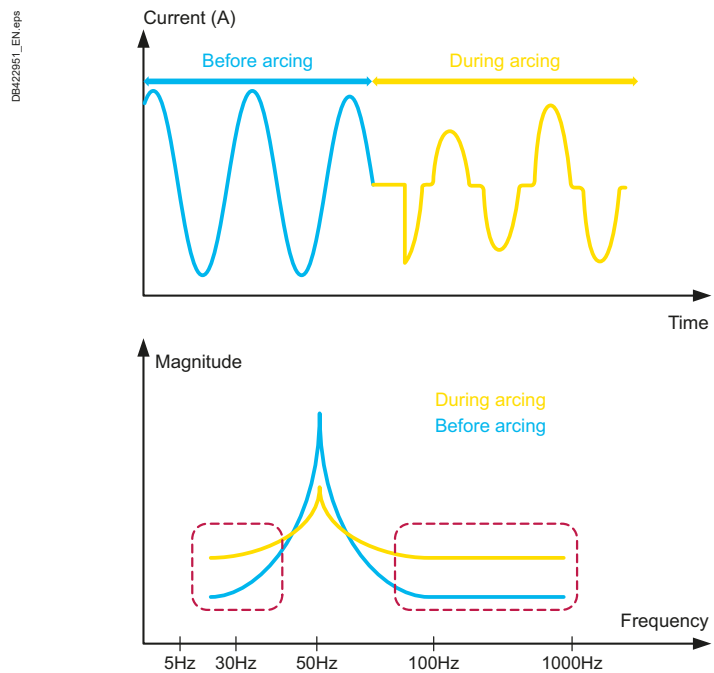


Fig. F88 Anomalies in electric currents that could indicate the presence of potentially dangerous arc faults

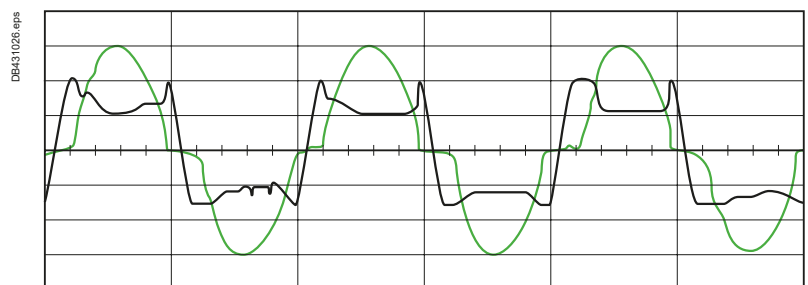


Fig. F89 Typical waveform of electric arc. Arc voltage (black) and current (green)

9 Protection against electrical fire risks

F54

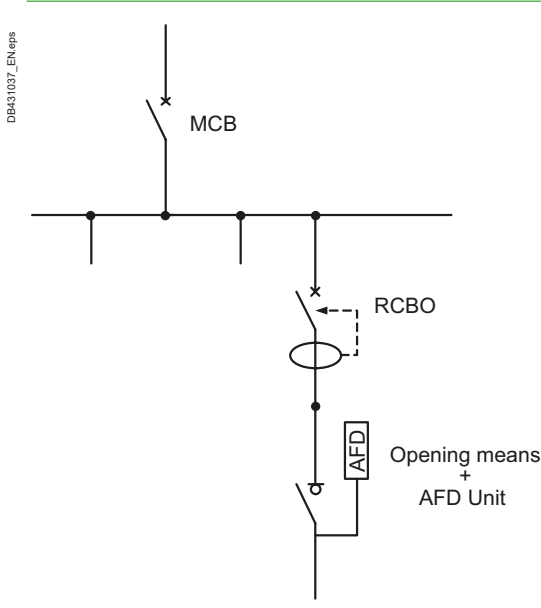


Fig. F91 AFDD unit with opening means installed in series with an RCBO

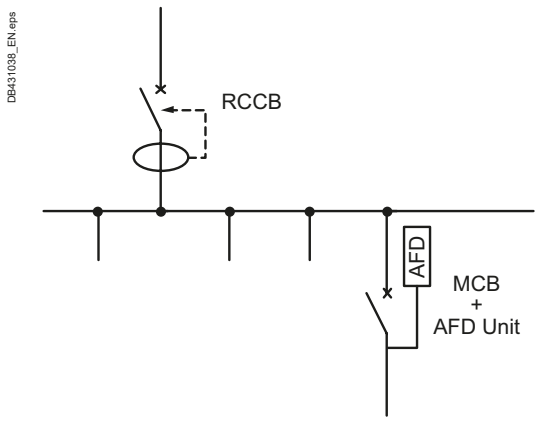


Fig. F92 AFDD unit with MCB



Fig. F93 Schneider Electric arc fault detection unit

Arc fault detection device types

AFDDs are assembled with a disconnection system that interrupts the current in case of arc fault, thus, they prevent fire to start.

According to IEC 62606 standard, three methods of construction of the arc fault detection devices are listed (See Fig. F90):

- AFDD as a single device, including an arc fault detection unit and opening means and intended to be installed in series with a protective device, that can be a MCB or RCBO (See Fig. F91)
- AFDD as one single device, including an arc fault detection unit and a protective device such as a MCB or RCBO (See Fig. F92)
- Arc fault detection unit that shall be assembled on site, with a protective device, such as MCB or RCBO. (See Fig. F93).

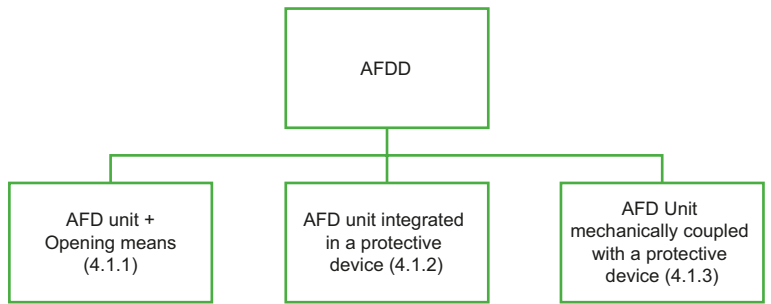


Fig. F90 Methods of construction of Arc fault detection devices

9 Protection against electrical fire risks

PB116754_epps



Fig. F94 Schneider Electric AFDD

Installation of Arc fault detection devices

Arc Fault Detection Devices (see Fig. F94) are designed to limit fire risks caused by the presence of arc fault currents in the final circuits of a fixed installation.

They are installed in electrical switchboards, to protect circuits supplying power sockets and lighting and are especially recommended in cases of renovation.

Since 2014, International Standard IEC 60364 - Electrical installations of buildings Part 4-42 makes the following recommendations surrounding the installation and application environments of AFDDs in residential and commercial buildings:

- In locations with sleeping accommodations (e.g., hotels, nursing homes, bedrooms in homes)
- In locations with risks of fire due to high quantities of flammable materials (e.g., barns, wood-working shops, stores of combustible materials)
- In locations with combustible constructional materials (e.g., wooden buildings)
- In fire propagating structures (e.g. high-rise buildings)
- In locations where irreplaceable goods are housed (e.g., museums)

It is recommended that AFDDs be installed at the place of origin of the low voltage final circuit to be protected (i.e., switchboard of an electrical installation).

More specifically, the installation of the AFDD is highly recommended to protect circuits with highest risk of fire, such as:

- Protruding cables (risk of knocks)
- Outside cables (greater risk of deterioration)
- Unprotected cables in secluded areas (like storage rooms)
- Aging, deteriorating wiring or wiring for which the connection boxes are inaccessible.

To know more about arc fault detection devices, you can download a white paper covering this topic:

<http://www.schneider-electric.com/en/download/document/EDCED117020EN>

9 Protection against electrical fire risks

9.4 Conclusion

In addition to protection against electric shock, protection against fire is another main target of a proper design of electrical installation. The minimum requirement is the coordination between overcurrent protective device and conductor permanent and short-time withstand. (See **Chapter G**). But other protective measures are recommended to reduce the risk of fire due to electrical installation.

- For main circuits and distribution circuits, more sensitive earth fault detection than the one necessary for protection against electric shock is recommended.
- For terminal circuits where mechanical withstand of conductor is lower, where the number of connection is higher, where portable equipment can be supplied, in addition to RCD, Arc fault detection device is recommended.

The table below tries to position the different types of **current-based** protections required or recommended for low voltage installations.

Earthing system	Protection against electric shock (IEC 60364-4-41)			Protection against thermal effect / Fire (IEC60364-4-42)			Protection against overcurrent (IEC 60364-4-43)
	Basic protection	Automatic disconnection	Additional protection	BE2 location ^[a]	Other location		
					Terminal Circuit	Distribution Circuit	
TNC	Insulation of live part / Barriers & enclosure	OCPD	NA	NA	NA	RS GFP ^[c]	OCPD (overload and short-circuit)
TNS		OCPD/RCD	RCD 30mA	300mA RCD	AFDD ^[b]	RCD ^[b]	
TT		RCD	RCD 30mA	AFDD	AFDD ^[b]	RCD ^[b]	
IT		OCPD/RCD	RCD 30mA		AFDD ^[b]	RCD ^[b]	

in **bold** = mandatory according to IEC60364

others = recommended to improve protection against fire risks

[a] BE2: Locations with risks of fire due to the nature of processed or stored materials (according to Table 51A of IEC 60364-5-51:2005).

[b] RCD may be already required for protection against electric shock in that case it will contribute to protection against risk of fire

[c] GFP is not described as such by IEC 60364 but is commonly used in some regions like North America

OCPD: overcurrent protective device

RCD: Residual current device (Sensitivity in the range 30mA – 30A)

RS GFP: Residual Sensing ground fault protection^[1] (Sensitivity 20% -100% circuit breaker rating)

Fig. F95 Overview of current based protection of low voltage circuit according to earthing system

[1] Cf. paragraph “Ground fault protection”.

F56

1	General	G2
	1.1 Methodology and definition	G2
	1.2 Overcurrent protection principles.....	G4
	1.3 Practical values for a protective scheme.....	G4
	1.4 Location of protective devices.....	G6
	1.5 Conductors in parallel.....	G6
2	Practical method for determining the smallest allowable cross-sectional area of circuit conductors	G7
	2.1 General method for cables	G7
	2.2 Recommended simplified approach for cables.....	G15
	2.3 Sizing of busbar trunking systems (busways)	G17
3	Determination of voltage drop	G19
	3.1 Maximum voltage drop limit.....	G19
	3.2 Calculation of voltage drop in steady load conditions.....	G20
4	Short-circuit current	G23
	4.1 Short-circuit current at the secondary terminals of a MV/LV distribution transformer ...	G23
	4.2 3-phase short-circuit current (Isc) at any point within a LV installation.....	G24
	4.3 Isc at the receiving end of a feeder as a function of the Isc at its sending end	G27
	4.4 Short-circuit current supplied by a generator or an inverter	G28
5	Particular cases of short-circuit current	G29
	5.1 Calculation of minimum levels of short-circuit current.....	G29
	5.2 Verification of the withstand capabilities of cables under short-circuit conditions	G33
6	Protective earthing conductor (PE)	G35
	6.1 Connection and choice	G35
	6.2 Conductor sizing	G36
	6.3 Protective conductor between MV/LV transformer and the Main Low Voltage Switchboard (MLVS)	G38
	6.4 Equipotential conductor.....	G39
7	The neutral conductor	G40
	7.1 Sizing the neutral conductor	G40
	7.2 Protection of the neutral conductor	G42
	7.3 Breaking of the neutral conductor.....	G42
	7.4 Isolation of the neutral conductor	G42
8	Worked example of cable calculation	G44

Component parts of an electric circuit and its protection are determined such that all normal and abnormal operating conditions are satisfied

1.1 Methodology and definition

Methodology (see Fig. G1)

Following a preliminary analysis of the power requirements of the installation, as described in Chapter A section 4, a study of cabling^[1] and its electrical protection is undertaken, starting at the origin of the installation, through the intermediate stages to the final circuits.

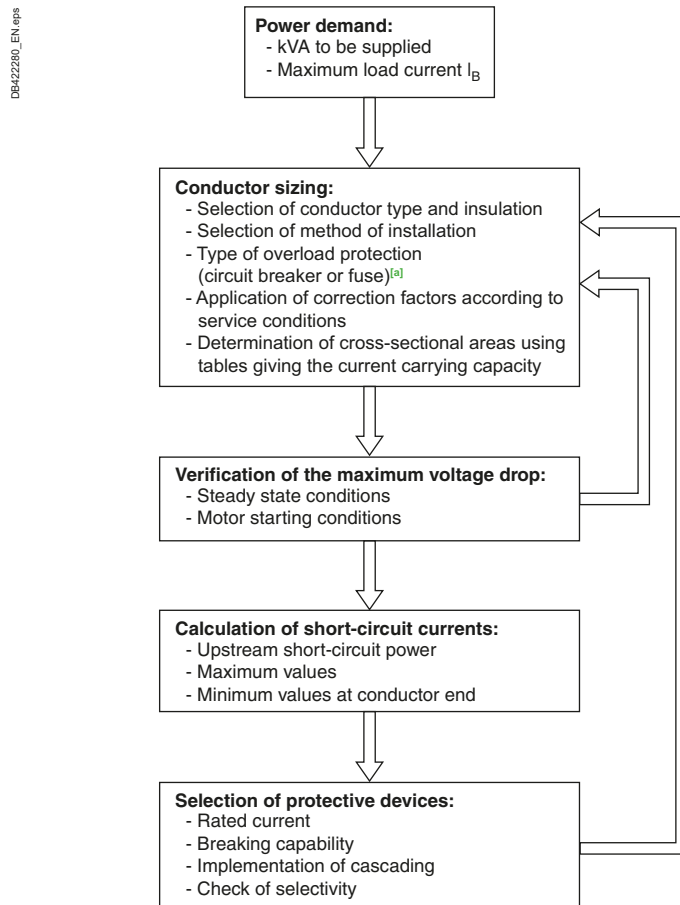
The cabling and its protection at each level must satisfy several conditions at the same time, in order to ensure a safe and reliable installation, e.g. it must:

- Carry the permanent full load current, and normal short-time overcurrents
- Not cause voltage drops likely to result in an inferior performance of certain loads, for example: an excessively long acceleration period when starting a motor, etc.

Moreover, the protective devices (circuit breakers or fuses) must:

- Protect the cabling and busbars for all levels of overcurrent, up to and including short-circuit currents
- Ensure protection of persons against indirect contact hazards (fault protection), particularly in TN- and IT- earthed systems, where the length of circuits may limit the magnitude of short-circuit currents, thereby delaying automatic disconnection (it may be remembered that TT- earthed installations are necessarily protected at the origin by a RCD, generally rated at 300 mA).

The cross-sectional areas of conductors are determined by the general method described in Sub-clause 2 of this Chapter. Apart from this method some national standards may prescribe a minimum cross-sectional area to be observed for reasons of mechanical endurance. Particular loads (as noted in Chapter N) require that the cable supplying them be oversized, and that the protection of the circuit be likewise modified.



[a] The type of overload protection (fuse or circuit breaker) has a direct impact on conductor sizing, as detailed in paragraph 1.3.

Fig. G1 Flow-chart for the selection of cable size and protective device rating for a given circuit

[1] The term “cabling” in this chapter, covers all insulated conductors, including multi-core and single-core cables and insulated wires drawn into conduits, etc.

Definitions

Maximum load current: I_b

■ At the final circuits level, this design current (according to IECV "International Electrotechnical Vocabulary" ref 826-11-10) corresponds to the rated kVA of the load. In the case of motor-starting, or other loads which take a high in-rush current, particularly where frequent starting is concerned (e.g. lift motors, resistance-type spot welding, and so on) the cumulative thermal effects of the overcurrents must be taken into account. Both cables and thermal type relays are affected.

■ At all upstream circuit levels this current corresponds to the kVA to be supplied, which takes into account the diversity and utilization factors, k_s and k_u respectively, as shown in Fig. G2.

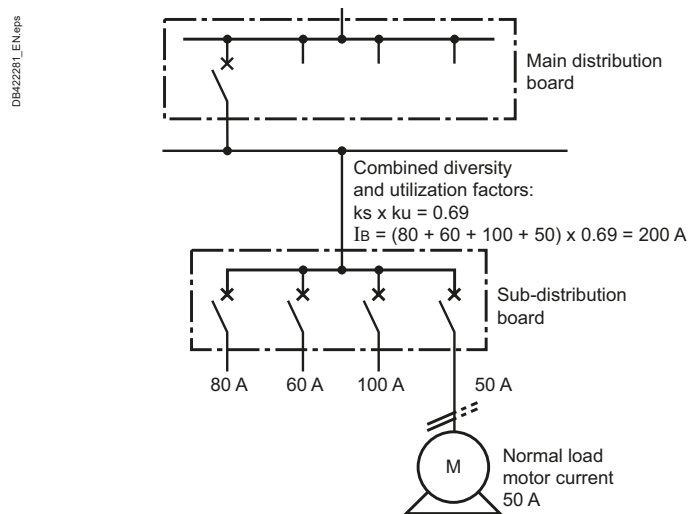


Fig. G2 Calculation of maximum load current I_b

Maximum permissible current: I_z

Current carrying capacity I_z is the maximum permissible that the cabling for the circuit can carry indefinitely, without reducing its normal life expectancy.

The current depends, for a given cross sectional area of conductors, on several parameters:

- Constitution of the cable and cable-way (Cu or Alu conductors; PVC or EPR etc. insulation; number of active conductors)
- Ambient temperature
- Method of installation
- Influence of neighbouring circuits.

Overcurrents

An overcurrent occurs each time the value of current exceeds the maximum load current I_b for the load concerned.

This current must be cut off with a rapidity that depends upon its magnitude, if permanent damage to the cabling (and appliance if the overcurrent is due to a defective load component) is to be avoided.

Overcurrents of relatively short duration can however, occur in normal operation; two types of overcurrent are distinguished:

■ Overloads

These overcurrents can occur in healthy electric circuits, for example, due to a number of small short-duration loads which occasionally occur co-incidentally: motor starting loads, and so on. If either of these conditions persists however beyond a given period (depending on protective-relay settings or fuse ratings) the circuit will be automatically cut off.

■ Short-circuit currents

These currents result from the failure of insulation between live conductors or/and between live conductors and earth (on systems having low-impedance-earthed neutrals) in any combination, viz:

- 3 phases short-circuited (and to neutral and/or earth, or not)
- 2 phases short-circuited (and to neutral and/or earth, or not)
- 1 phase short-circuited to neutral (and/or to earth)

1 General

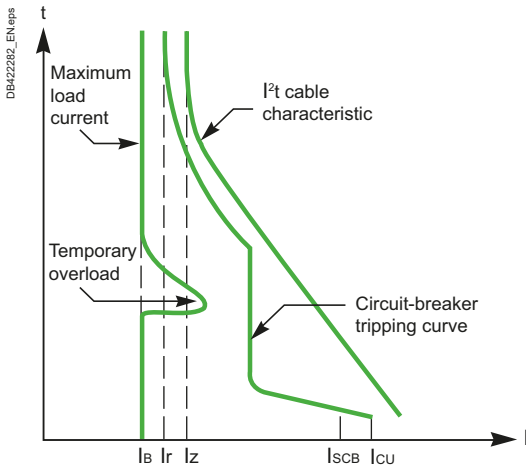


Fig. G3 Circuit protection by circuit breaker

1.2 Overcurrent protection principles

A protective device is provided at the origin of the circuit concerned (see Fig. G3 and Fig. G4).

- Acting to cut-off the current in a time shorter than that given by the I^2t characteristic of the circuit cabling
- But allowing the maximum load current I_b to flow indefinitely

The characteristics of insulated conductors when carrying short-circuit currents can, for periods up to 5 seconds following short-circuit initiation, be determined approximately by the formula:

$I^2t = k^2 S^2$ which shows that the allowable heat generated is proportional to the squared cross-sectional-area of the conductor.

where

t: Duration of short-circuit current (seconds)

S: Cross sectional area of insulated conductor (mm^2)

I: Short-circuit current (A r.m.s.)

k: Insulated conductor constant (values of k are given in Fig. G5)

For a given insulated conductor, the maximum permissible current varies according to the environment. For instance, for a high ambient temperature ($\theta_{a1} > \theta_{a2}$), I_{z1} is less than I_{z2} (see Fig. G5). θ means "temperature".

Note:

- I_{sc} : 3-phase short-circuit current
- I_{scB} : rated 3-ph. short-circuit breaking current of the circuit breaker
- I_r (or I_{rth})^[1]: regulated "nominal" current level; e.g. a 50 A nominal circuit breaker can be regulated to have a protective range, i.e. a conventional overcurrent tripping level (see Fig. G6 opposite page) similar to that of a 30 A circuit breaker.

1.3 Practical values for a protective scheme

The following methods are based on rules laid down in the IEC standards, and are representative of the practices in many countries.

General rules

A protective device (circuit breaker or fuse) functions correctly if:

- Its nominal current or its setting current I_n is greater than the maximum load current I_b but less than the maximum permissible current I_z for the circuit, i.e. $I_b \leq I_n \leq I_z$ corresponding to zone "a" in Fig. G6
- Its tripping current I_2 "conventional" setting is less than $1.45 I_z$ which corresponds to zone "b" in Fig. G6

The "conventional" setting tripping time may be 1 hour or 2 hours according to local standards and the actual value selected for I_2 . For fuses, I_2 is the current (denoted I_f) which will operate the fuse in the conventional time.

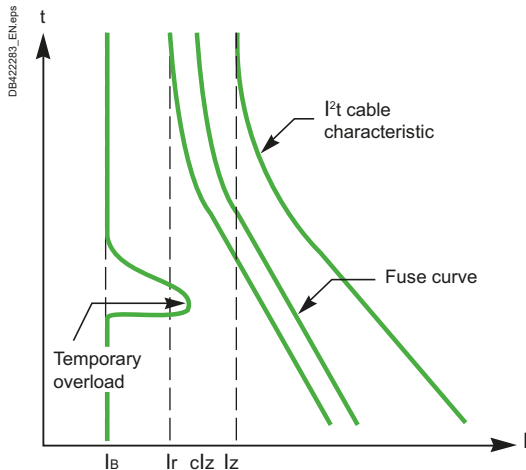


Fig. G4 Circuit protection by fuses

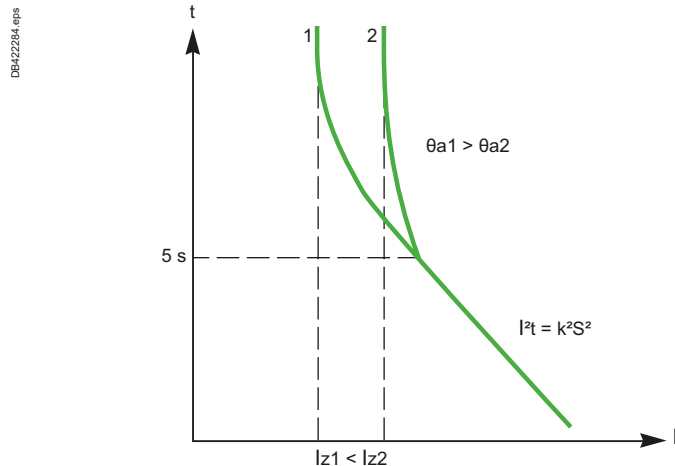


Fig. G5 I^2t characteristic of an insulated conductor at two different ambient temperatures

[1] Both designations are commonly used in different standards.

1 General

DB422385_EN.eps

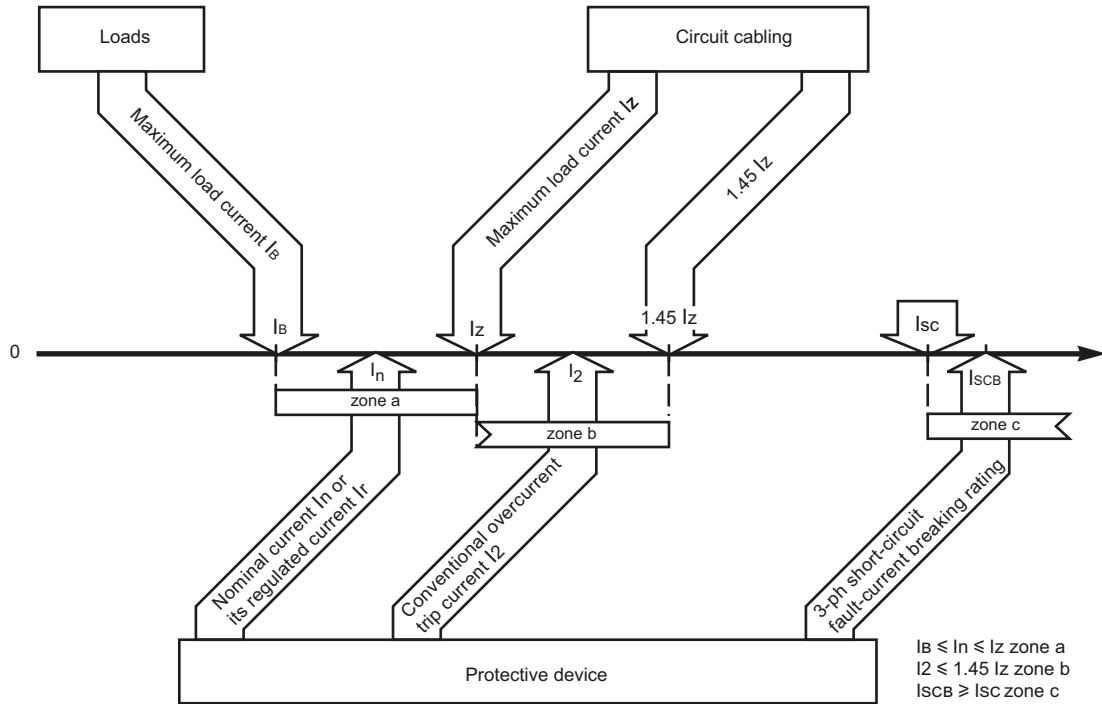


Fig. G6 Current levels for determining circuit breaker or fuse characteristics

- Its 3-phase short-circuit fault-current breaking rating is greater than the 3-phase short-circuit current existing at its point of installation. This corresponds to zone "c" in Fig. G6.

Applications

■ Protection by circuit breaker

By virtue of its high level of precision the current I_2 is always less than $1.45 I_n$ (or $1.45 I_r$) so that the condition $I_2 \leq 1.45 I_z$ (as noted in the "general rules" above) will always be respected.

□ Particular case

If the circuit breaker itself does not protect against overloads, it is necessary to ensure that, at a time of lowest value of short-circuit current, the overcurrent device protecting the circuit will operate correctly. This particular case is examined in Sub-clause 5.1.

■ Protection by fuses

The condition $I_2 \leq 1.45 I_z$ must be taken into account, where I_2 is the fusing (melting level) current, equal to $k_2 \times I_n$ (k_2 ranges from 1.6 to 1.9) depending on the particular fuse concerned.

A further factor k_3 has been introduced ($k_3 = \frac{k_2}{1.45}$) such that $I_2 \leq 1.45 I_z$

will be valid if $I_n \leq I_z/k_3$.

For fuses type gG:

$I_n < 16 \text{ A} \rightarrow k_3 = 1.31$

$I_n \geq 16 \text{ A} \rightarrow k_3 = 1.10$

Moreover, the short-circuit current breaking capacity of the fuse I_{scf} must exceed the level of 3-phase short-circuit current at the point of installation of the fuse(s).

■ Association of different protective devices

The use of protective devices which have fault-current ratings lower than the fault level existing at their point of installation are permitted by IEC and many national standards in the following conditions:

- There exists upstream, another protective device which has the necessary short-circuit rating, and
- The amount of energy allowed to pass through the upstream device is less than that which can be withstood without damage by the downstream device and all associated cabling and appliances.

Criteria for circuit breakers:
 $I_b \leq I_n \leq I_z$ and $I_{scB} \geq I_{sc}$.

Criteria for fuses:
 $I_b \leq I_n \leq I_z/k_3$ and $I_{scf} \geq I_{sc}$.

1 General

A protective device is, in general, required at the origin of each circuit

In practice this arrangement is generally exploited in:

- The association of circuit breakers/fuses
- The technique known as “cascading” or “series rating” in which the strong current-limiting performance of certain circuit breakers effectively reduces the severity of downstream short-circuits

Possible combinations which have been tested in laboratories are indicated in certain manufacturers catalogues.

1.4 Location of protective devices

General rule (see Fig. G7a)

A protective device is necessary at the origin of each circuit where a reduction of permissible maximum current level occurs.

Possible alternative locations in certain circumstances (see Fig. G7b)

The protective device may be placed part way along the circuit:

- If AB is not in proximity to combustible material, and
- If no socket-outlets or branch connections are taken from AB

Three cases may be useful in practice:

- Consider case (1) in the diagram
- AB ≤ 3 metres, and
- AB has been installed to reduce to a practical minimum the risk of a short-circuit (wires in heavy steel conduit for example)
- Consider case (2)
- The upstream device P1 protects the length AB against short-circuits in accordance with Sub-clause 5.1
- Consider case (3)
- The overload device (S) is located adjacent to the load. This arrangement is convenient for motor circuits. The device (S) constitutes the control (start/stop) and overload protection of the motor while (SC) is: either a circuit breaker (designed for motor protection) or fuses type aM
- The short-circuit protection (SC) located at the origin of the circuit conforms with the principles of Sub-clause 5.1

Circuits with no protection (see Fig. G7c)

Either

- The protective device P1 is calibrated to protect the cable S2 against overloads and short-circuits

Or

- Where the breaking of a circuit constitutes a risk, e.g.
- Excitation circuits of rotating machines
- circuits of large lifting electromagnets
- the secondary circuits of current transformers

No circuit interruption can be tolerated, and the protection of the cabling is of secondary importance.

1.5 Conductors in parallel

Conductors of the same cross-sectional-area, the same length, and of the same material, can be connected in parallel.

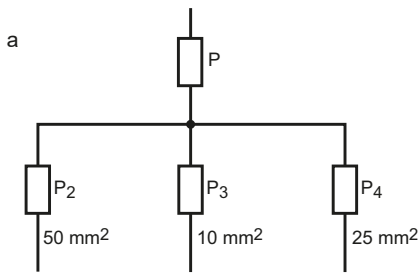
The maximum permissible current is the sum of the individual-core maximum currents, taking into account the mutual heating effects, method of installation, etc.

Protection against overload and short-circuits is identical to that for a single-cable circuit.

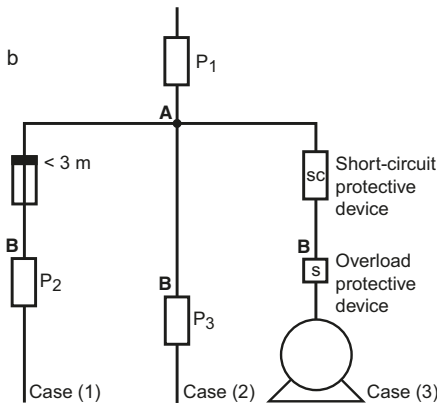
The following precautions should be taken to avoid the risk of short-circuits on the paralleled cables:

- Additional protection against mechanical damage and against humidity, by the introduction of supplementary protection
- The cable route should be chosen so as to avoid close proximity to combustible materials.

DB42286a.eps



DB42286b_EN.eps



DB42286c_EN.eps

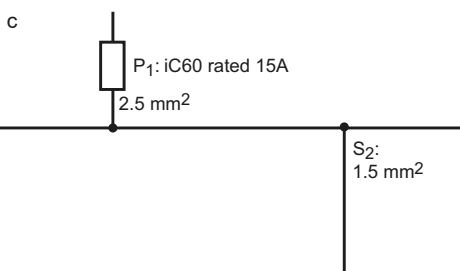


Fig. G7 Location of protective devices

2 Practical method for determining the smallest allowable cross-sectional area of circuit conductors

The reference international standard for the study of cabling is IEC 60364-5-52: “Electrical installation of buildings - Part 5-52: Selection and erection of electrical equipment - Wiring system”.

A summary of this standard is presented here, with examples of the most commonly used methods of installation. The current-carrying capacities of conductors in all different situations are given in annex A of the standard. A simplified method for use of the tables of annex A is proposed in informative annex B of the standard.

2.1 General method for cables

Possible methods of installation for different types of conductors or cables

The different admissible methods of installation are listed in Fig. G8, in conjunction with the different types of conductors and cables.

Conductors and cables		Method of installation							
		Without fixings	Clipped direct	Conduit systems	Cable trunking systems (including skirting trunking, flush floor trunking)	Cable ducting systems	Cable ladder, cable tray, cable racks	On insulators	Support wire
Bare conductors		-	-	-	-	-	-	+	-
Insulated conductors ^[b]		-	-	+	+ ^[a]	+	-	+	-
Sheathed cables (including armoured and mineral insulated)	Multi-core	+	+	+	+	+	+	0	-
	Single-core	0	+	+	+	+	+	0	+

- + Permitted.
- Not permitted.
- 0 Not applicable, or not normally used in practice.

^[a] Insulated conductors are admitted if the cable trunking systems provide at least the degree of protection IP4X or IPXXD and if the cover can only be removed by means of a tool or a deliberate action.
^[b] Insulated conductors which are used as protective conductors or protective bonding conductors may use any appropriate method of installation and need not be laid in conduits, trunking or ducting systems.

Fig. G8 Selection of wiring systems (table A.52.1 of IEC 60364-5-52)

Possible methods of installation for different situations:

Different methods of installation can be implemented in different situations. The possible combinations are presented in Fig. G9.

Situations		Method of installation							
		Without fixings	Clipped direct	Conduit systems	Cable trunking systems (including skirting trunking, flush floor trunking)	Cable ducting systems	Cable ladder, cable tray, cable racks	On insulators	Support wire
Building voids	Accessible	40	33	41, 42	6, 7, 8, 9, 12	43, 44	30, 31, 32, 33, 34	-	0
	Not accessible	40	0	41, 42	0	43	0	0	0
Cable channel		56	56	54, 55			30, 31, 32, 34	-	-
Buried in ground		72, 73	0	70, 71	70, 71	70, 71	0	-	-
Embedded in structure		57, 58	3	1, 2, 59, 60	50, 51, 52, 53	46, 45	0	-	-
Surface mounted		-	20, 21, 22, 23, 33	4, 5	6, 7, 8, 9, 12	6, 7, 8, 9	30, 31, 32, 34	36	-
Overhead/free in air		-	33	0	10, 11	10, 11	30, 31, 32, 34	36	35
Window frames		16	0	16	0	0	0	-	-
Architrave		15	0	15	0	0	0	-	-
Immersed 1		+	+	+	-	+	0	-	-

- Not permitted.
- 0 Not applicable or not normally used in practice.
- + Follow manufacturer's instructions.

Note: The number in each box, e.g. 40, 46, refers to the number of the method of installation in Table A.52.3.

Fig. G9 Erection of wiring systems (table A.52.2 of IEC 60364-5-52)

G - Sizing and protection of conductors

2 Practical method for determining the smallest allowable cross-sectional area of circuit conductors

Examples of wiring systems and reference methods of installations

An illustration of some of the many different wiring systems and methods of installation is provided in **Fig. G10**.

Several reference methods are defined (with code letters A to G), grouping installation methods having the same characteristics relative to the current-carrying capacities of the wiring systems.

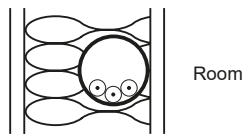
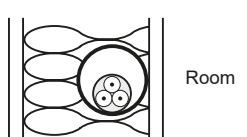
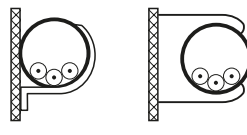
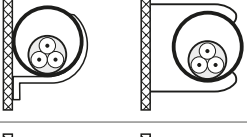
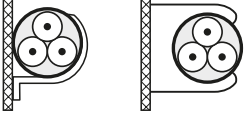
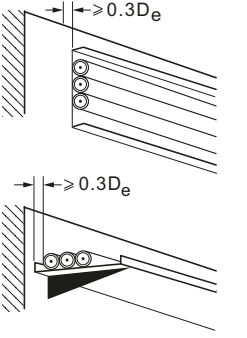
Item No	Method of installation	Description	Reference method of installation to be used to obtain current-carrying capacity
1	 Room	Insulated conductors or single-core cables in conduit in a thermally insulated wall	A1
2	 Room	Multi-core cables in conduit in a thermally insulated wall	A2
4		Insulated conductors or single-core cables in conduit on a wooden, or masonry wall or spaced less than 0.3 x conduit diameter from it	B1
5		Multi-core cable in conduit on a wooden, or masonry wall or spaced less than 0.3 x conduit diameter from it	B2
20		Single-core or multi-core cables: - fixed on, or spaced less than 0.3 x cable diameter from a wooden wall	C
30		Single-core or multi-core cables: on unperforated tray run horizontally or vertically	C

Fig. G10 Examples of methods of installation (part of table A.52.3 of IEC 60364-5-52)

G - Sizing and protection of conductors

2 Practical method for determining the smallest allowable cross-sectional area of circuit conductors

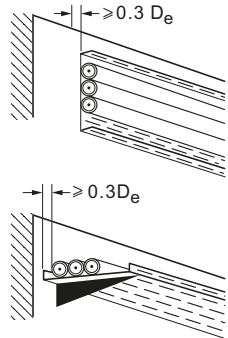
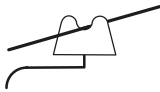

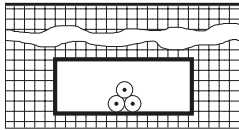
Item No	Method of installation	Description	Reference method of installation to be used to obtain current-carrying capacity
31		Single-core or multi-core cables: on perforated tray run horizontally or vertically	E or F
36		Bare or insulated conductors on insulators	G
70		Multi-core cables in conduit or in cable ducting in the ground	D1
71		Single-core cable in conduit or in cable ducting in the ground	D1

Fig. G10 Examples of methods of installation (part of table A.52.3 of IEC 60364-5-52)

G9

Maximum operating temperature:

The current-carrying capacities given in the subsequent tables have been determined so that the maximum insulation temperature is not exceeded for sustained periods of time.

For different type of insulation material, the maximum admissible temperature is given in Fig. G11.

Type of insulation	Temperature limit °C
Polyvinyl-chloride (PVC)	70 at the conductor
Cross-linked polyethylene (XLPE) and ethylene propylene rubber (EPR)	90 at the conductor
Mineral (PVC covered or bare exposed to touch)	70 at the sheath
Mineral (bare not exposed to touch and not in contact with combustible material)	105 at the sheath

Fig. G11 Maximum operating temperatures for types of insulation (table 52.1 of IEC 60364-5-52)

2 Practical method for determining the smallest allowable cross-sectional area of circuit conductors

Correction factors:

In order to take service conditions of the installation into account, correction factors have been introduced.

The cross-sectional area of cables is determined using the current-carrying capacity of the cable I_Z , multiplied by correction factors:

$$I'_Z = I_Z \cdot k_1 \cdot k_2 \dots$$

where:

I_Z = current carrying capacity of the cable in the reference installation method

I'_Z = "corrected" current carrying capacity of the cable in real installation conditions

$k_1, k_2 \dots$ = corrections factors, detailed in the following paragraphs

The cross sectional area of cables is then chosen in order to ensure that their "corrected" current-carrying capacity I'_Z is higher than the rated load current I_B : $I_B \leq I'_Z$

■ Ambient temperature

The current-carrying capacities of **cables in the air** are based on an average air temperature equal to 30 °C. For other temperatures, the correction factor is given in **Fig. G12** for PVC, EPR and XLPE insulation material.

The related correction factor is here noted k_1 .

Ambient air temperature °C	Insulation	
	PVC	XLPE and EPR
10	1.22	1.15
15	1.17	1.12
20	1.12	1.08
25	1.06	1.04
30	1	1
35	0.94	0.96
40	0.87	0.91
45	0.79	0.87
50	0.71	0.82
55	0.61	0.76
60	0.50	0.71
65	-	0.65
70	-	0.58
75	-	0.50
80	-	0.41

Fig. G12 Correction factors for ambient air temperatures other than 30 °C to be applied to the current-carrying capacities for cables in the air (from table B.52.14 of IEC 60364-5-52)

The current-carrying capacities of **cables in the ground** are based on an average ground temperature equal to 20 °C. For other temperatures, the correction factor is given in **Fig. G13** for PVC, EPR and XLPE insulation material.

The related correction factor is here noted k_2 .

Ground temperature °C	Insulation	
	PVC	XLPE and EPR
10	1.10	1.07
15	1.05	1.04
20	1	1
25	0.95	0.96
30	0.89	0.93
35	0.84	0.89
40	0.77	0.85
45	0.71	0.80
50	0.63	0.76
55	0.55	0.71
60	0.45	0.65
65	-	0.60
70	-	0.53
75	-	0.46
80	-	0.38

Fig. G13 Correction factors for ambient ground temperatures other than 20 °C to be applied to the current-carrying capacities for cables in ducts in the ground (from table B.52.15 of IEC 60364-5-52)

G - Sizing and protection of conductors

2 Practical method for determining the smallest allowable cross-sectional area of circuit conductors

■ Soil thermal resistivity

The current-carrying capacities of cables in the ground are based on a ground resistivity equal to 2.5 K.m/W. For other values, the correction factor is given in **Fig. G14**.

The related correction factor is here noted k3.

Thermal resistivity, K.m/W	0.5	0.7	1	1.5	2	2.5	3
Correction factor for cables in buried ducts	1.28	1.20	1.18	1.1	1.05	1	0.96
Correction factor for direct buried cables	1.88	1.62	1.5	1.28	1.12	1	0.90

Note 1: The correction factors given have been averaged over the range of conductor sizes and types of installation included in Tables B.52.2 to B.52.5. The overall accuracy of correction factors is within $\pm 5\%$.

Note 2: The correction factors are applicable to cables drawn into buried ducts; for cables laid direct in the ground the correction factors for thermal resistivities less than 2.5 K.m/W will be higher. Where more precise values are required they may be calculated by methods given in the IEC 60287 series.

Note 3: The correction factors are applicable to ducts buried at depths of up to 0.8 m.

Note 4: It is assumed that the soil properties are uniform. No allowance had been made for the possibility of moisture migration which can lead to a region of high thermal resistivity around the cable. If partial drying out of the soil is foreseen, the permissible current rating should be derived by the methods specified in the IEC 60287 series.

Fig. G14 Correction factors for cables in buried ducts for soil thermal resistivities other than 2.5 K.m/W to be applied to the current-carrying capacities for reference method D (table B.52.16 of IEC 60364-5-52)

Nature of soil	k3
Very wet soil (saturated)	1.21
Wet soil	1.13
Damp soil	1.05
Dry soil	1.00
Very dry soil (sunbaked)	0.86

Fig. G15 Correction factor k3 depending on the nature of soil

مقاومت حرارتی (k.m/W)	شرایط خاک	وضعیت آب و هوا
0.7	خیلی مرطوب	بسیار مرطوب
1	مرطوب	بارانی
2	خشک	به ندرت بارانی
3	خیلی خشک	بدون باران و یا کم

رطوبت اثر تعیین کننده ای در مقاومت مخصوص خاک دارد - برای هر منطقه این مقدار بایستی اندازه گیری شود. طبق استاندارد IEC-60364-5-52

Based on experience, a relationship exist between the soil nature and resistivity. Then, empiric values of correction factors k3 are proposed in **Fig. G15**, depending on the nature of soil.

■ Grouping of conductors or cables

The current-carrying capacities given in the subsequent tables relate to single circuits consisting of the following numbers of loaded conductors:

- Two insulated conductors or two single-core cables, or one twin-core cable (applicable to single-phase circuits);
- Three insulated conductors or three single-core cables, or one three-core cable (applicable to three-phase circuits).

Where more insulated conductors or cables are installed in the same group, a group reduction factor (here noted k4) shall be applied.

Examples are given in **Fig. G16** to **Fig. G18** for different configurations (installation methods, in free air or in the ground).

Fig. G16 gives the values of correction factor k4 for different configurations of unbundled cables or conductors, grouping of more than one circuit or multi-core cables.

Arrangement (cables touching)	Number of circuits or multi-core cables											Reference methods	
	1	2	3	4	5	6	7	8	9	12	16		20
Bunched in air, on a surface, embedded or enclosed	1.00	0.80	0.70	0.65	0.60	0.57	0.54	0.52	0.50	0.45	0.14	0.38	Methods A to F
Single layer on wall, floor or unperforated tray	1.00	0.85	0.79	0.75	0.73	0.72	0.72	0.71	0.70	No further reduction factor for more than nine circuits or multi-core cables			Method C
Single layer fixed directly under a wooden ceiling	0.95	0.81	0.72	0.68	0.66	0.64	0.63	0.62	0.61				Methods E and F
Single layer on a perforated horizontal or vertical tray	1.00	0.88	0.82	0.77	0.75	0.73	0.73	0.72	0.72				
Single layer on ladder support or cleats etc.	1.00	0.87	0.82	0.80	0.80	0.79	0.79	0.78	0.78				

Fig. G16 Reduction factors for groups of more than one circuit or of more than one multi-core cable (table B.52.17 of IEC 60364-5-52)

G11

G - Sizing and protection of conductors

2 Practical method for determining the smallest allowable cross-sectional area of circuit conductors

Fig. G17 gives the values of correction factor k_4 for different configurations of unburied cables or conductors, for groups of more than one circuit of single-core cables in free air.

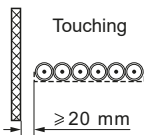
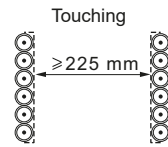
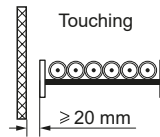
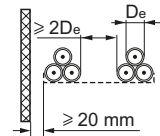
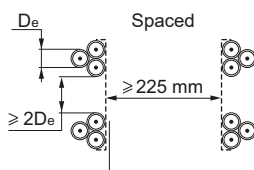
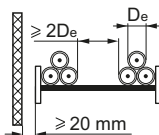
Method of installation		Number of tray	Number of three-phase circuits			Use as a multiplier to rating for	
			1	2	3		
Perforated trays	31		1	0.98	0.91	0.87	Three cables in horizontal formation
			2	0.96	0.87	0.81	
			3	0.95	0.85	0.78	
Vertical perforated trays	31		1	0.96	0.86	Three cables in vertical formation	
2	0.95	0.84					
Ladder supports, cleats, etc.	32 33 34		1	1.00	0.97	0.96	Three cables in horizontal formation
			2	0.98	0.93	0.89	
			3	0.97	0.90	0.86	
Perforated trays	31		1	1.00	0.98	0.96	Three cables in trefoil formation
2	0.97	0.93	0.89				
3	0.96	0.92	0.86				
Vertical perforated trays	31		1	1.00	0.91	0.89	
2	1.00	0.90	0.86				
Ladder supports, cleats, etc.	32 33 34		1	1.00	1.00	1.00	
			2	0.97	0.95	0.93	
			3	0.96	0.94	0.90	

Fig. G17 Reduction factors for groups of more than one circuit of single-core cables to be applied to reference rating for one circuit of single-core cables in free air - Method of installation F. (table B.52.21 of IEC 60364-5-52)

G - Sizing and protection of conductors

2 Practical method for determining the smallest allowable cross-sectional area of circuit conductors

Fig. G18 gives the values of correction factor k_4 for different configurations of cables or conductors laid directly in the ground.

Number of circuits	Cable to cable clearance ^[a]				
	Nil (cables touching)	One cable diameter	0.125 m	0.25 m	0.5 m
2	0.75	0.80	0.85	0.90	0.90
3	0.65	0.70	0.75	0.80	0.85
4	0.60	0.60	0.70	0.75	0.80
5	0.55	0.55	0.60	0.70	0.80
6	0.50	0.55	0.60	0.70	0.80
7	0.45	0.51	0.59	0.67	0.76
8	0.43	0.48	0.57	0.65	0.75
9	0.41	0.46	0.55	0.63	0.74
12	0.36	0.42	0.51	0.59	0.71
16	0.32	0.38	0.47	0.56	0.38
20	0.29	0.35	0.44	0.53	0.66

[a] Multi-core cables



[a] Single-core cables



Fig. G18 Reduction factors for more than one circuit, single-core or multi-core cables laid directly in the ground. Installation method D. (table B.52.18 of IEC 60364-5-52)

■ Harmonic current

The current-carrying capacity of three-phase, 4-core or 5-core cables is based on the assumption that only 3 conductors are fully loaded.

However, when harmonic currents are circulating, the neutral current can be significant, and even higher than the phase currents. This is due to the fact that the 3rd harmonic currents of the three phases do not cancel each other, and sum up in the neutral conductor.

This of course affects the current-carrying capacity of the cable, and a correction factor noted here k_5 shall be applied.

In addition, if the 3rd harmonic percentage h_3 is greater than 33 %, the neutral current is greater than the phase current and the cable size selection is based on the neutral current. The heating effect of harmonic currents in the phase conductors has also to be taken into account.

The values of k_5 depending on the 3rd harmonic content are given in Fig. G19.

Third harmonic content of phase current %	Correction factor	
	Size selection is based on phase current	Size selection is based on neutral current
0 - 15	1.0	
15 - 33	0.86	
33 - 45		0.86
> 45		1.0 ^[a]

[a] If the neutral current is more than 135 % of the phase current and the cable size is selected on the basis of the neutral current then the three phase conductors will not be fully loaded. The reduction in heat generated by the phase conductors offsets the heat generated by the neutral conductor to the extent that it is not necessary to apply any reduction factor to the current carrying capacity for three loaded conductors

Fig. G19 Correction factors for harmonic currents in four-core and five-core cables (table E.52.1 of IEC 60364-5-52)

2 Practical method for determining the smallest allowable cross-sectional area of circuit conductors

Admissible current as a function of nominal cross-sectional area of conductors

IEC standard 60364-5-52 proposes extensive information in the form of tables giving the admissible currents as a function of cross-sectional area of cables. Many parameters are taken into account, such as the method of installation, type of insulation material, type of conductor material, number of loaded conductors.

As an example, **Fig. G20** gives the current-carrying capacities for different methods of installation of PVC insulation, three loaded copper or aluminium conductors, free air or in ground.

Nominal cross-sectional area of conductor mm ²	Installation methods of Table B.52.1						
	A1	A2	B1	B2	C	D1	D2
1	2	3	4	5	6	7	8
Cooper							
1.5	13.5	13	15.5	15	17.5	18	19
2.5	18	17.5	21	20	24	24	24
4	24	23	28	27	32	30	33
6	31	29	36	34	41	38	41
10	42	39	50	46	57	50	54
16	56	52	68	62	76	64	70
25	73	68	89	80	96	82	92
35	89	83	110	99	119	98	110
50	108	99	134	118	144	116	130
70	136	125	171	149	184	143	162
95	164	150	207	179	223	169	193
120	188	172	239	206	259	192	220
150	216	196	262	225	299	217	246
185	245	223	296	255	341	243	278
240	286	261	346	297	403	280	320
300	328	298	394	339	464	316	359
Aluminium							
2.5	14	13.5	16.5	15.5	18.5	18.5	
4	18.5	17.5	22	21	25	24	
6	24	23	28	27	32	30	
10	32	31	39	36	44	39	
16	43	41	53	48	59	50	53
25	57	53	70	62	73	64	69
35	70	65	86	77	90	77	83
50	84	78	104	92	110	91	99
70	107	98	133	116	140	112	122
95	129	118	161	139	170	132	148
120	149	135	186	160	197	150	169
150	170	155	204	176	227	169	189
185	194	176	230	199	259	190	214
240	227	207	269	232	305	218	250
300	261	237	306	265	351	247	282

Note: In columns 3, 5, 6, 7 and 8, circular conductors are assumed for sizes up to and including 16 mm². Values for larger sizes relate to shaped conductors and may safely be applied to circular conductors.

Fig. G20 Current-carrying capacities in amperes for different methods of installation, PVC insulation, three loaded conductors, copper or aluminium, conductor temperature: 70 °C, ambient temperature: 30 °C in air, 20 °C in ground (table B.52.4 of IEC 60364-5-52)

2 Practical method for determining the smallest allowable cross-sectional area of circuit conductors

2.2 Recommended simplified approach for cables

In order to facilitate the selection of cables, 2 simplified tables are proposed, for unburied and buried cables.

These tables summarize the most commonly used configurations and give easier access to the information.

■ Unburied cables:

Reference methods	Number of loaded conductors and type of insulation												
		2 PVC	3 PVC		3 XLPE	2 XLPE							
A1													
A2	3 PVC	2 PVC		3 XLPE	2 XLPE								
B1				3 PVC	2 PVC		3 XLPE		2 XLPE				
B2			3 PVC	2 PVC		3 XLPE	2 XLPE						
C					3 PVC		2 PVC	3 XLPE		2 XLPE			
E						3 PVC	2 PVC	3 XLPE	2 XLPE		2 XLPE		
F							3 PVC		2 PVC	3 XLPE		2 XLPE	
1	2	3	4	5	6	7	8	9	10	11	12	13	
Size (mm ²)													
Cooper													
1.5	13	13.5	14.5	15.5	17	18.5	19.5	22	23	24	26	-	
2.5	17.5	18	19.5	21	23	25	27	30	31	33	36	-	
4	23	24	26	28	31	34	36	40	42	45	49	-	
6	29	31	34	36	40	43	46	51	54	58	63	-	
10	39	42	46	50	54	60	63	70	75	80	86	-	
16	52	56	61	68	73	80	85	94	100	107	115	-	
25	68	73	80	89	95	101	110	119	127	135	149	161	
35	-	-	-	110	117	126	137	147	158	169	185	200	
50	-	-	-	134	141	153	167	179	192	207	225	242	
70	-	-	-	171	179	196	213	229	246	268	289	310	
95	-	-	-	207	216	238	258	278	298	328	352	377	
120	-	-	-	239	249	276	299	322	346	382	410	437	
150	-	-	-	-	285	318	344	371	395	441	473	504	
185	-	-	-	-	324	362	392	424	450	506	542	575	
240	-	-	-	-	380	424	461	500	538	599	641	679	
Aluminium													
2.5	13.5	14	15	16.5	18.5	19.5	21	23	24	26	28	-	
4	17.5	18.5	20	22	25	26	28	31	32	35	38	-	
6	23	24	26	28	32	33	36	39	42	45	49	-	
10	31	32	36	39	44	46	49	54	58	62	67	-	
16	41	43	48	53	58	61	66	73	77	84	91	-	
25	53	57	63	70	73	78	83	90	97	101	108	121	
35	-	-	-	86	90	96	103	112	120	126	135	150	
50	-	-	-	104	110	117	125	136	146	154	164	184	
70	-	-	-	133	140	150	160	174	187	198	211	237	
95	-	-	-	161	170	183	195	211	227	241	257	289	
120	-	-	-	186	197	212	226	245	263	280	300	337	
150	-	-	-	-	226	245	261	283	304	324	346	389	
185	-	-	-	-	256	280	298	323	347	371	397	447	
240	-	-	-	-	300	330	352	382	409	439	470	530	

Fig. G21 Current-carrying capacity in amperes (table C.52.1 of IEC 60364-5-52)

2 Practical method for determining the smallest allowable cross-sectional area of circuit conductors

Correction factors are given in **Fig. G22** for groups of several circuits or multi-core cables:

Arrangement	Number of circuits or multi-core cables									
	1	2	3	4	6	9	12	16	20	
Embedded or enclosed	1.00	0.80	0.70	0.70	0.55	0.50	0.45	0.40	0.40	
Single layer on walls, floors or on unperforated trays	1.00	0.85	0.80	0.75	0.70	0.70	-	-	-	
Single layer fixed directly under a ceiling	0.95	0.80	0.70	0.70	0.65	0.60	-	-	-	
Single layer on perforated horizontal trays or on vertical trays	1.00	0.90	0.80	0.75	0.75	0.70	-	-	-	
Single layer on cable ladder supports or cleats, etc	1.00	0.85	0.80	0.80	0.80	0.80	-	-	-	

Fig. G22 Reduction factors for groups of several circuits or of several multi-core cables (table C.52.3 of IEC 60364-5-52)

■ Buried cables:

Installation method	Size mm ²	Number of loaded conductors and type of insulation			
		Two PVC	Three PVC	Two XLPE	Three XLPE
D1/D2	Copper				
	1.5	22	18	26	22
	2.5	29	24	34	29
	4	38	31	44	37
	6	47	39	56	46
	10	63	52	73	61
	16	81	67	95	79
	25	104	86	121	101
	35	125	103	146	122
	50	148	122	173	144
	70	183	151	213	178
	95	216	179	252	211
	120	246	203	287	240
	150	278	230	324	271
	185	312	258	363	304
240	361	297	419	351	
300	408	336	474	396	
D1/D2	Aluminium				
	2.5	22	18.5	26	22
	4	29	24	34	29
	6	36	30	42	36
	10	48	40	56	47
	16	62	52	73	61
	25	80	66	93	78
	35	96	80	112	94
	50	113	94	132	112
	70	140	117	163	138
	95	166	138	193	164
	120	189	157	220	186
	150	213	178	249	210
	185	240	200	279	236
	240	277	230	322	272
300	313	260	364	308	

Fig. G23 Current-carrying capacity in amperes (table B.52-1 of IEC 60364-5-52)

2 Practical method for determining the smallest allowable cross-sectional area of circuit conductors

2.3 Sizing of busbar trunking systems (busways)

The selection of busbar trunking systems is very straightforward, using the data provided by the manufacturer. Methods of installation, insulation materials, correction factors for grouping are not relevant parameters for this technology making the selection of busways much more straightforward than the sizing of a traditional distribution with cables.

The cross section area of any given model has been determined by the manufacturer based on:

- The rated current,
- An ambient air temperature equal to 35 °C,
- 3 loaded conductors.

Rated current

The rated current can be calculated taking into account:

- The layout,
- The current absorbed by the different loads connected along the trunking system.

Ambient temperature

A correction factor has to be applied for temperature higher than 35 °C. The correction factor applicable is provided by the busway manufacturer. As an example, for Schneider Electric medium and high power range (up to 4000 A) the correction factor is given in Fig. G24.

°C	35	40	45	50	55
Correction factor	1	0.97	0.93	0.90	0.86

Fig. G24 Correction factor for air temperature higher than 35 °C

Neutral current

Where 3rd harmonic currents are circulating, the neutral conductor may be carrying a significant current and the corresponding additional power losses must be taken into account.

Fig. G25 represents the maximum admissible phase and neutral currents (per unit) in a high power busbar trunking system as functions of 3rd harmonic level.

For more information, see Chapter E - paragraph 2.3 "Harmonic currents in the selection of busbar trunking systems (busways)".

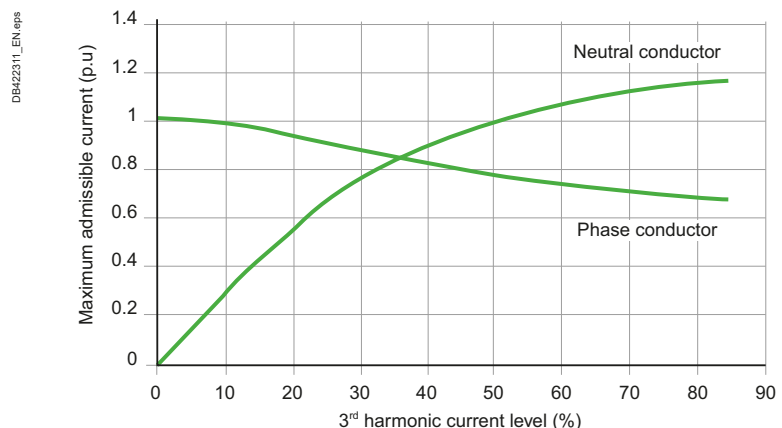


Fig. G25 Maximum admissible currents (p.u.) in a busbar trunking system as functions of the 3rd harmonic level

The layout of the trunking system depends on the position of the current consumers, the location of the power source and the possibilities for fixing the system.

2 Practical method for determining the smallest allowable cross-sectional area of circuit conductors

- One single distribution line serves a 4 to 6 meter area
- Protection devices for current consumers are placed in tap-off units, connected directly to usage points.
- One single feeder supplies all current consumers of different powers.

Once the trunking system layout is established, it is possible to calculate the absorbed current I_n on the distribution line.

I_n is equal to the sum of absorbed currents by the current I_n consumers: $I_n = \sum I_B$.

The current consumers do not all work at the same time and are not permanently on full load, so we have to use a clustering coefficient k_S : $I_n = \sum (I_B \cdot k_S)$.

Application	Number of current consumers	Ks Coefficient
Lighting, Heating		1
Distribution (engineering workshop)	2...3	0.9
	4...5	0.8
	6...9	0.7
	10...40	0.6
	40 and over	0.5

Note: for industrial installations, remember to take into account upgrading of the machine equipment base. As for a switchboard, a 20 % margin is recommended: $I_n \leq I_B \times k_S \times 1.2$.

Fig. G26 Rated diversity factor according to the number of current consumers

G18

G - Sizing and protection of conductors

3 Determination of voltage drop

The impedance of circuit conductors is low but not negligible: when carrying load current there is a voltage drop between the origin of the circuit and the load terminals. The correct operation of a load (a motor, lighting circuit, etc.) depends on the voltage at its terminals being maintained at a value close to its rated value. It is necessary therefore to determine the circuit conductors such that at full-load current, the load terminal voltage is maintained within the limits required for correct performance.

This section deals with methods of determining voltage drops, in order to check that:

- They comply with the particular standards and regulations in force
- They can be tolerated by the load
- They satisfy the essential operational requirements.

3.1 Maximum voltage drop limit

Maximum allowable voltage-drop vary from one country to another. Typical values for LV installations are given below in Fig. G27.

Type of installations	Lighting circuits	Other uses (heating and power)
Low voltage installations supplied directly from a public low voltage distribution system	3 %	5 %
Low voltage installation supplied from private LV supply	6 %	8 %

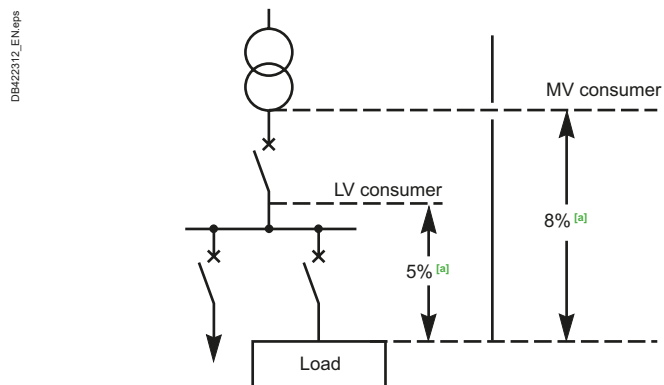
Fig. G27 Maximum voltage-drop between the origin of an installation and any load point (IEC60364-5-52 table G.52.1)

G19

These voltage-drop limits refer to normal steady-state operating conditions and do not apply at times of motor starting, simultaneous switching (by chance) of several loads, etc. as mentioned in Chapter A Sub-clause 4.3 (diversity and utilization factors, etc.). When voltage drops exceed the values shown in Fig. G27, larger cables (wires) must be used to correct the condition.

The value of 8 %, while permitted, can lead to problems for motor loads; for example:

- In general, satisfactory motor performance requires a voltage within $\pm 5\%$ of its rated nominal value in steady-state operation,
- Starting current of a motor can be 5 to 7 times its full-load value (or even higher). If an 8 % voltage drop occurs at full-load current, then a drop of 40 % or more will occur during start-up. In such conditions the motor will either:
 - Stall (i.e. remain stationary due to insufficient torque to overcome the load torque) with consequent over-heating and eventual trip-out
 - Or accelerate very slowly, so that the heavy current loading (with possibly undesirable low-voltage effects on other equipment) will continue beyond the normal start-up period
- Finally an 8 % voltage drop represents a continuous power loss, which, for continuous loads will be a significant waste of (metered) energy. For these reasons it is recommended that the maximum value of 8 % in steady operating conditions should not be reached on circuits which are sensitive to under-voltage problems (see Fig. G28).



[a] Between the LV supply point and the load.

Fig. G28 Maximum voltage drop (the values shown here are for circuits other than lighting circuits)

G - Sizing and protection of conductors

3 Determination of voltage drop

3.2 Calculation of voltage drop in steady load conditions

Use of formulae

Fig. G29 below gives formulae commonly used to calculate voltage drop in a given circuit per kilometre of length (copper cable with XLPE insulation).

If:

- I_B : The full load current in amps
- L : Length of the cable in kilometres
- R : Resistance of the cable conductor in Ω/km

$$R = \frac{23.7^{[1]} \Omega \text{ mm}^2 / \text{km}}{S(\text{c.s.a. in mm}^2)} \text{ for copper}$$

$$R = \frac{37.6^{[1]} \Omega \text{ mm}^2 / \text{km}}{S(\text{c.s.a. in mm}^2)} \text{ for aluminium}$$

Note: R is negligible above a c.s.a. of 500 mm^2

- X : inductive reactance of a conductor in Ω/km

Note: X is negligible for conductors of c.s.a. less than 50 mm^2 . In the absence of any other information, take X as being equal to 0.08 Ω/km .

- φ : phase angle between voltage and current in the circuit considered, generally:

- Incandescent lighting: $\cos \varphi = 1$
- Led lighting: $\cos \varphi > 0.9$
- Fluorescent with electronic ballast: $\cos \varphi > 0.9$
- Motor power:

- At start-up: $\cos \varphi = 0.35$

- In normal service: $\cos \varphi = 0.8$

- U_n : phase-to-phase voltage
- V_n : phase-to-neutral voltage

For prefabricated pre-wired ducts and busways (busbar trunking systems), resistance and inductive reactance values are given by the manufacturer.

Circuit	Voltage drop (ΔU)	
	in volts	in %
Phase/phase	$\Delta U = 2 I_B (R \cos \varphi + X \sin \varphi) L$	$\frac{100 \Delta U}{U_n}$
Phase/neutral	$\Delta U = 2 I_B (R \cos \varphi + X \sin \varphi) L$	$\frac{100 \Delta U}{V_n}$
Balanced 3-phase: 3 phases (with or without neutral)	$\Delta U = \sqrt{3} I_B (R \cos \varphi + X \sin \varphi) L$	$\frac{100 \Delta U}{U_n}$

Fig. G29 Voltage-drop formulae

Simplified table

Calculations may be avoided by using Fig. G30 next page, which gives, with an ampere, in terms of:

- Kinds of circuit use: motor circuits with $\cos \varphi$ close to 0.8, or lighting with a $\cos \varphi$ close to 1.
- Type of circuit; single-phase or 3-phase

Voltage drop in a cable is then given by:

$$K \times I_B \times L$$

K is given by the table,

I_B is the full-load current in amps,

L is the length of cable in km.

The column motor power " $\cos \varphi = 0.35$ " of Fig. G30 may be used to compute the voltage drop occurring during the start-up period of a motor (see example no. 1 after the Fig. G30).

[1] Values of r according to IEC60909-0 and Cenelec TR 50480. See Fig. G38.

G - Sizing and protection of conductors

3 Determination of voltage drop

این جدول در
ABB
HANDBOOK
به گونه ای دیگر
آورده شده است

Copper cables							Aluminium cables						
c.s.a. in mm ²	Single-phase circuit			Balanced three-phase circuit			c.s.a. in mm ²	Single-phase circuit			Balanced three-phase circuit		
	Motor power		Lighting	Motor power		Lighting		Motor power		Lighting	Motor power		Lighting
	Normal service	Start-up		Normal service	Start-up			Normal service	Start-up		Normal service	Start-up	
	cos φ = 0.8	cos φ = 0.35	cos φ = 1	cos φ = 0.8	cos φ = 0.35	cos φ = 1		cos φ = 0.8	cos φ = 0.35	cos φ = 1	cos φ = 0.8	cos φ = 0.35	cos φ = 1
1.5	25.4	11.2	32	33	9.7	27							
2.5	15.3	6.8	19	13.2	5.9	16							
4	9.6	4.3	11.9	8.3	3.7	10.3	6	10.1	4.5	12.5	8.8	3.9	10.9
6	6.4	2.9	7.9	5.6	2.5	6.8	10	6.1	2.8	7.5	5.3	2.4	6.5
10	3.9	1.8	4.7	3.4	1.6	4.1	16	3.9	1.8	4.7	3.3	1.6	4.1
16	2.5	1.2	3	2.1	1	2.6	25	2.50	1.2	3	2.2	1	2.6
25	1.6	0.81	1.9	1.4	0.70	1.6	35	1.8	0.90	2.1	1.6	1.78	1.9
35	1.18	0.62	1.35	1	0.54	1.2	50	1.4	0.70	1.6	1.18	0.61	1.37
50	0.89	0.50	1.00	0.77	0.43	0.86	70	0.96	0.53	1.07	0.83	0.46	0.93
70	0.64	0.39	0.68	0.55	0.34	0.59	120	0.60	0.37	0.63	0.52	0.32	0.54
95	0.50	0.32	0.50	0.43	0.28	0.43	150	0.50	0.33	0.50	0.43	0.28	0.43
120	0.41	0.29	0.40	0.36	0.25	0.34	185	0.42	0.29	0.41	0.36	0.25	0.35
150	0.35	0.26	0.32	0.30	0.23	0.27	240	0.35	0.26	0.31	0.30	0.22	0.27
185	0.30	0.24	0.26	0.26	0.21	0.22	300	0.30	0.24	0.25	0.26	0.21	0.22
240	0.25	0.22	0.20	0.22	0.19	0.17	400	0.25	0.22	0.19	0.21	0.19	0.16
300	0.22	0.12	0.16	0.19	0.18	0.14	500	0.22	0.20	0.15	0.19	0.18	0.13

Fig. G30 Phase-to-phase voltage drop ΔU for a circuit, in volts per ampere per km

G21

Examples

Example 1 (see Fig. G31)

A three-phase 35 mm² copper cable 50 metres long supplies a 400 V motor taking:

- 100 A at a cos φ = 0.8 on normal permanent load
- 500 A (5 I_n) at a cos φ = 0.35 during start-up

The voltage drop at the origin of the motor cable in normal circumstances (i.e. with the distribution board of Fig. G31 distributing a total of 1000 A) is 10 V phase-to-phase.

What is the voltage drop at the motor terminals:

- In normal service?
- During start-up?

Solution:

- Voltage drop in normal service conditions:

$$\Delta U\% = 100 \frac{\Delta U}{U_n}$$

Table G30 shows 1 V/A/km so that:

$$\Delta U \text{ for the cable} = 1 \times 100 \times 0.05 = 5 \text{ V}$$

$$\Delta U \text{ total} = 10 + 5 = 15 \text{ V} = \text{i.e.}$$

$$\frac{15}{400} \times 100 = 3.75 \%$$

This value is less than that authorized (8 %) and is satisfactory.

- Voltage drop during motor start-up:

$$\Delta U_{\text{cable}} = 0.54 \times 500 \times 0.05 = 13.5 \text{ V}$$

Owing to the additional current taken by the motor when starting, the voltage drop at the distribution board will exceed 10 Volts.

Supposing that the infeed to the distribution board during motor starting is 900 + 500 = 1400 A then the voltage drop at the distribution board will increase approximately pro rata, i.e.

$$\frac{10 \times 1400}{1000} = 14 \text{ V}$$

$$\Delta U \text{ distribution board} = 14 \text{ V}$$

$$\Delta U \text{ for the motor cable} = 13 \text{ V}$$

$$\Delta U \text{ total} = 13.5 + 14 = 27.5 \text{ V i.e.}$$

$$\frac{27.5}{400} \times 100 = 6.9 \%$$

a value which is satisfactory during motor starting.

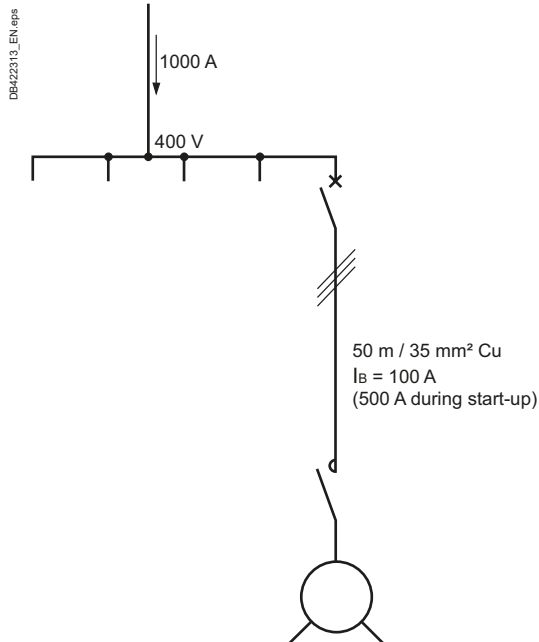


Fig. G31 Example 1

3 Determination of voltage drop

Example 2 (see Fig. G32)

A 3-phase 4-wire copper line of 70 mm² c.s.a. and a length of 50 m passes a current of 150 A. The line supplies, among other loads, 3 single-phase lighting circuits, each of 2.5 mm² c.s.a. copper 20 m long, and each passing 20 A.

It is assumed that the currents in the 70 mm² line are balanced and that the three lighting circuits are all connected to it at the same point.

What is the voltage drop at the end of the lighting circuits?

Solution:

■ Voltage drop in the 4-wire line:

$$\Delta U\% = 100 \frac{\Delta U}{U_n}$$

Fig. G30 shows 0.59 V/A/km

$$\Delta U \text{ line} = 0.59 \times 150 \times 0.05 = 4.4 \text{ V phase-to-phase}$$

$$\text{which gives: } \frac{4.4}{\sqrt{3}} = 2.54 \text{ V phase to neutral.}$$

■ Voltage drop in any one of the lighting single-phase circuits:

$$\Delta U \text{ for a single-phase circuit} = 19 \times 20 \times 0.02 = 7.6 \text{ V}$$

The total voltage drop is therefore

$$7.6 + 2.54 = 10.1 \text{ V}$$

$$\frac{10.1 \text{ V}}{230 \text{ V}} \times 100 = 4.4 \%$$

This value is satisfactory, being less than the maximum permitted voltage drop of 6%.

DB422314_EN.eps

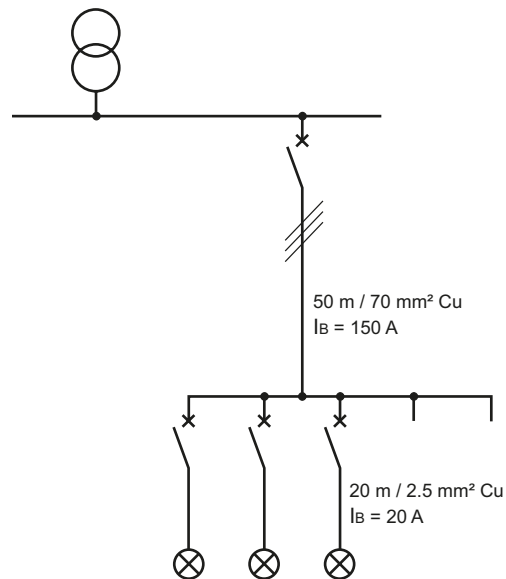


Fig. G32 Exemple 2

4 Short-circuit current

Knowing the levels of 3-phase symmetrical short-circuit currents (Isc) at different points in an installation is an essential feature of its design

A knowledge of 3-phase symmetrical short-circuit current values (Isc) at strategic points of an installation is necessary in order to determine switchgear (breaking capacity), cables (thermal withstand rating), protective devices (selective trip settings) and so on...

In the following notes a 3-phase short-circuit of zero impedance (the so-called bolted short-circuit) fed through a typical MV/LV distribution transformer will be examined. Except in very unusual circumstances, this type of fault is the most severe, and is certainly the simplest to calculate.

Short-circuit currents occurring in a network supplied from a generator and also in DC systems are dealt with in Chapter N.

The simplified calculations and practical rules which follow give conservative results of sufficient accuracy, in the large majority of cases, for installation design purposes.

4.1 Short-circuit current at the secondary terminals of a MV/LV distribution transformer

The case of one transformer

■ In a simplified approach, the impedance of the MV system is assumed to be

negligibly small, so that: $I_{sc} = \frac{I_n \times 100}{U_{sc}}$ where $I_n = \frac{S \times 10^3}{U_{20} \sqrt{3}}$ and:

S = kVA rating of the transformer

U₂₀ = phase-to-phase secondary no-load voltage

I_n = rated current of the transformer

I_{sc} = short-circuit current in amps

U_{sc} = short-circuit impedance voltage of the transformer in %.

Typical values of U_{sc} for distribution transformers are given in Fig. G33.

Transformer rating (kVA)	U _{sc} in %	
	Oil-immersed	Cast-resin dry type
50 to 750	4	6
800 to 3200	6	6

Fig. G33 Typical values of U_{sc} for different kVA ratings of transformers with MV windings ≤ 20 kV

■ Example

400 kVA transformer, 420 V at no load

U_{sc} = 4 %

$$I_n = \frac{400 \times 10^3}{420 \times \sqrt{3}} = 550 \text{ A} \quad I_{sc} = \frac{550 \times 100}{4} = 13.7 \text{ kA}$$

The case of several transformers in parallel feeding a busbar

The value of fault current on an outgoing circuit immediately downstream of the busbars (see Fig. G34) can be estimated as the sum of the I_{sc} from each transformer calculated separately.

It is assumed that all transformers are supplied from the same MV network, in which case the values obtained from Fig. G33 when added together will give a slightly higher fault-level value than would actually occur.

Other factors which have not been taken into account are the impedance of the busbars and of the cable between transformers and circuit breakers.

The conservative fault-current value obtained however, is sufficiently accurate for basic installation design purposes. The choice of circuit breakers and incorporated protective devices against short-circuit and fault currents is described in Chapter H Sub-clause 4.4.

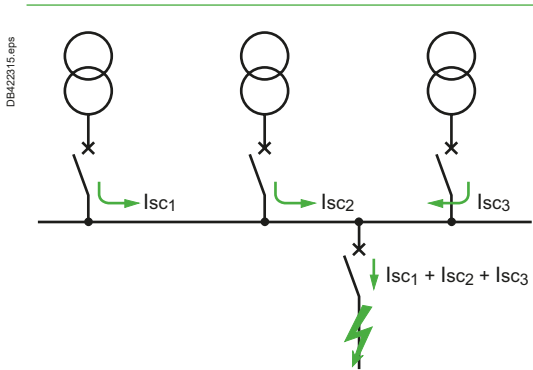


Fig. G34 Case of several transformers in parallel

4 Short-circuit current

4.2 3-phase short-circuit current (I_{sc}) at any point within a LV installation

In a 3-phase installation I_{sc} at any point is given by:

$$I_{sc} = \frac{U_{20}}{\sqrt{3} Z_T} \quad \text{where}$$

U₂₀ = phase-to-phase voltage of the open circuited secondary windings of the power supply transformer(s).

Z_T = total impedance per phase of the installation upstream of the fault location (in Ω).

Method of calculating Z_T

Each component of an installation (MV network, transformer, cable, busbar, and so on...) is characterized by its impedance Z, comprising an element of resistance (R) and an inductive reactance (X). It may be noted that capacitive reactances are not important in short-circuit current calculations.

The parameters R, X and Z are expressed in ohms, and are related by the sides of a right angled triangle, as shown in the impedance diagram of Fig. G35.

The method consists in dividing the network into convenient sections, and to calculate the R and X values for each.

Where sections are connected in series in the network, all the resistive elements in the section are added arithmetically; likewise for the reactances, to give R_T and X_T. The impedance (Z_T) for the combined sections concerned is then calculated from:

$$Z_T = \sqrt{R_T^2 + X_T^2}$$

Any two sections of the network which are connected in parallel, can, if predominantly both resistive (or both inductive) be combined to give a single equivalent resistance (or reactance) as follows:

Let R₁ and R₂ be the two resistances connected in parallel, then the equivalent resistance R₃ will be given by:

$$R_3 = \frac{R_1 \times R_2}{R_1 + R_2} \quad \text{or for reactances } X_3 = \frac{X_1 \times X_2}{X_1 + X_2}$$

It should be noted that the calculation of X₃ concerns only separated circuit without mutual inductance. If the circuits in parallel are close together the value of X₃ will be notably higher.

Determination of the impedance of each component

■ Network upstream of the MV/LV transformer (see Fig. G36)

The 3-phase short-circuit fault level P_{sc}, in kA or in MVA^[1] is given by the power supply authority concerned, from which an equivalent impedance can be deduced.

P _{sc}	U ₂₀ (V)	R _a (mΩ)	X _a (mΩ)
250 MVA	420	0.07	0.7
500 MVA	420	0.035	0.351

Fig. G36 The impedance of the MV network referred to the LV side of the MV/LV transformer

A formula which makes this deduction and at the same time converts the impedance to an equivalent value at LV is given, as follows:

$$Z_a = \frac{U_{20}^2}{P_{sc}}$$

where

Z_a = impedance of the MV voltage network, expressed in milli-ohms

U₂₀ = phase-to-phase no-load LV voltage, expressed in volts

P_{sc} = MV 3-phase short-circuit fault level, expressed in kVA

The upstream (MV) resistance R_a is generally found to be negligible compared with the corresponding X_a, the latter then being taken as the ohmic value for Z_a. If more accurate calculations are necessary, X_a may be taken to be equal to 0.995 Z_a and R_a equal to 0.1 X_a.

Fig. G36 gives values for R_a and X_a corresponding to the most common MV^[2] short-circuit levels in utility power-supply networks, namely, 250 MVA and 500 MVA.

D0422316.eps

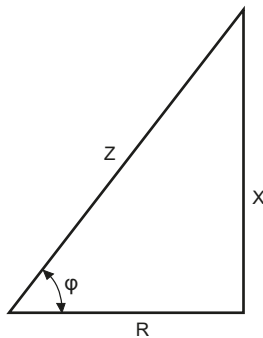


Fig. G35 Impedance diagram

[1] Short-circuit MVA: 3 EL I_{sc} where:

■ EL = phase-to-phase nominal system voltage expressed in kV (r.m.s.)

■ I_{sc} = 3-phase short-circuit current expressed in kA (r.m.s.)

[2] up to 36 kV

4 Short-circuit current

■ Transformers (see Fig. G37)

The impedance Z_{tr} of a transformer, viewed from the LV terminals, is given by the formula:

$$Z_{tr} = \frac{U_{20}^2}{S_n} \times \frac{U_{sc}}{100} \text{ in milli-ohms}$$

where:

U_{20} = open-circuit secondary phase-to-phase voltage expressed in volts

S_n = rating of the transformer (in kVA)

U_{sc} = the short-circuit impedance voltage of the transformer expressed in %

The transformer windings resistance R_{tr} can be derived from the total load-losses as follows:

$$P_{cu} = 3I_n^2 \times R_{tr} \text{ so that } R_{tr} = \frac{P_{cu} \times 10^3}{3I_n^2} \text{ in milli-ohms}$$

where

P_{cu} = total load-losses in watts

I_n = nominal full-load current in amps

R_{tr} = resistance of one phase of the transformer in milli-ohms (the LV and corresponding MV winding for one LV phase are included in this resistance value).

$$X_{tr} = \sqrt{Z_{tr}^2 - R_{tr}^2}$$

Note: for an approximate calculation, in the absence of more precise information on transformer characteristics, Cenelec 50480 suggests to use the following guidelines:

■ if U_{20} is not known, it may be assumed to be 1.05 U_n

■ in the absence of more precise information, the following values may be used:

$R_{tr} = 0.31 Z_{tr}$ and $X_{tr} = 0.95 Z_{tr}$

Example: for a transformer of 630kVA with $U_{sc}=4\%$ / $U_n = 400V$, approximate calculation gives:

■ $U_{20} = 400 \times 1.05 = 420V$

■ $Z_{tr} = 420^2 / 630 \times 4\% = 11 \text{ m}\Omega$

■ $R_{tr} = 0.31 Z_{tr} = 3.5 \text{ m}\Omega$ and $X_{tr} = 0.95 Z_{tr} = 10.6 \text{ m}\Omega$

Rated Power (kVA)	Oil-immersed				Cast-resin			
	Usc (%)	Rtr (mΩ)	Xtr (mΩ)	Ztr (mΩ)	Usc (%)	Rtr (mΩ)	Xtr (mΩ)	Ztr (mΩ)
100		37.9	9.5	70.6	6	37.0	99.1	105.8
160	4	16.2	41.0	44.1	6	18.6	63.5	66.2
200	4	11.9	33.2	35.3	6	14.1	51.0	52.9
250	4	9.2	26.7	28.2	6	10.7	41.0	42.3
315	4	6.2	21.5	22.4	6	8.0	32.6	33.6
400	4	5.1	16.9	17.6	6	6.1	25.8	26.5
500	4	3.8	13.6	14.1	6	4.6	20.7	21.2
630	4	2.9	10.8	11.2	6	3.5	16.4	16.8
800	6	2.9	12.9	13.2	6	2.6	13.0	13.2
1000	6	2.3	10.3	10.6	6	1.9	10.4	10.6
1250	6	1.8	8.3	8.5	6	1.5	8.3	8.5
1600	6	1.4	6.5	6.6	6	1.1	6.5	6.6
2000	6	1.1	5.2	5.3	6	0.9	5.2	5.3

Fig. G37 Resistance, reactance and impedance values for typical distribution 400V transformers (no-load voltage = 420 V) with MV windings ≤ 20 kV

■ Busbars

The resistance of busbars is generally negligible, so that the impedance is practically all reactive, and amounts to approximately 0.15 mΩ/metre^[1] length for LV busbars (doubling the spacing between the bars increases the reactance by about 10 % only). In practice, it's almost never possible to estimate the busbar length concerned by a short-circuit downstream a switchboard.

■ Circuit conductors

The resistance of a conductor is given by the formula: $R_c = \rho \frac{L}{S}$

where

ρ = the resistivity of the conductor material at the normal operating temperature:

ρ has to be considered:

□ at cold state (20°C) to determine maximum short-circuit current,

□ at steady state (normal operating temperature) to determine minimum short-circuit current.

L = length of the conductor in m

S = c.s.a. of conductor in mm²

	20 °C	PR/XLPE 90 °C	PVC 70 °C
Copper	18.51	23.69	22.21
Alu	29.41	37.65	35.29

Fig. G38 Values of ρ as a function of the temperature, cable insulation and cable core material, according to IEC60909-0 and Cenelec TR 50480 (in mΩ.mm²/m).

[1] For 50 Hz systems, but 0.18 mΩ/m length at 60 Hz

4 Short-circuit current

Cable reactance values can be obtained from the manufacturers. For c.s.a. of less than 50 mm² reactance may be ignored. In the absence of other information, a value of 0.08 mΩ/metre may be used (for 50 Hz systems) or 0.096 mΩ/metre (for 60 Hz systems). For busways (busbar trunking systems) and similar pre-wired ducting systems, the manufacturer should be consulted.

■ **Motors**

At the instant of short-circuit, a running motor will act (for a brief period) as a generator, and feed current into the fault.

In general, this fault-current contribution may be ignored. However, if the total power of motors running simultaneously is higher than 25 % of the total power of transformers, the influence of motors must be taken into account. Their total contribution can be estimated from the formula:

$$I_{scm} = 3.5 I_n \text{ from each motor i.e. } 3.5mI_n \text{ for } m \text{ similar motors operating concurrently.}$$

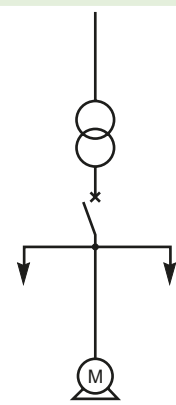
The motors concerned will be the 3-phase motors only; single-phase-motor contribution being insignificant.

■ **Fault-arc resistance**

Short-circuit faults generally form an arc which has the properties of a resistance. The resistance is not stable and its average value is low, but at low voltage this resistance is sufficient to reduce the fault-current to some extent. Experience has shown that a reduction of the order of 20 % may be expected. This phenomenon will effectively ease the current-breaking duty of a CB, but affords no relief for its fault-current making duty.

■ **Recapitulation table (see Fig. G39)**

G26



Supply network Figure G34	$\frac{R_a}{X_a} = 0.1$	$X_a = 0.995 Z_a; Z_a = \frac{U_{20}^2}{P_{sc}}$
Transformer Figure G35	$R_{tr} = \frac{P_{cu} \times 10^3}{3I_n^2}$ where $I_n = \frac{S_n \times 10^3}{U_{20}\sqrt{3}}$ Rtr is often negligible compared to Xtr for transformers > 100 kVA	$X_{tr} = \sqrt{Z_{tr}^2 - R_{tr}^2}$ with $Z_{tr} = \frac{U_{20}^2}{S_n} \times \frac{U_{sc}}{100}$
Circuit breaker	Not considered in practice	
Busbars	Negligible for S > 200 mm ² , below use the formula: $R = \rho \frac{L}{S}$ [a]	$X_b = 0.15 \text{ m}\Omega/\text{m}$
Circuit conductors [b]	$R = \rho \frac{L}{S}$ [a]	Cables: $X_c = 0.08 \text{ m}\Omega/\text{m}$
Motors	See Sub-clause 4.2 Motors (often negligible at LV)	
Three-phase maximum short circuit current in kA	$I_{sc} = \frac{U_{20}}{\sqrt{3} \sqrt{R_T^2 + X_T^2}}$	

U₂₀: Phase-to-phase no-load secondary voltage of MV/LV transformer (in volts).
 P_{sc}: 3-phase short-circuit power at MV terminals of the MV/LV transformers (in kVA).
 P_{cu}: 3-phase total losses of the MV/LV transformer (in watts).
 S_n: Rating of the MV/LV transformer (in kVA).
 U_{sc}: Short-circuit impedance voltage of the MV/LV transformer (in %).
 R_T: Total resistance. X_T: Total reactance

[a] ρ = resistivity at 20°C.

[b] If there are several conductors in parallel per phase, then divide the resistance of one conductor by the number of conductors. The reactance remains practically unchanged.

Fig. G39 Recapitulation table of impedances for different parts of a power-supply system

4 Short-circuit current

■ Example of short-circuit calculations (see Fig. G40)

LV installation	R (mΩ)	X (mΩ)	RT (mΩ)	XT (mΩ)	$I_{sc} = \frac{420}{\sqrt{3} \cdot \sqrt{R_T^2 + X_T^2}}$
MV network P _{sc} = 500 MVA	0.035	0.351			
Transformer 20 kV/420 V P _n = 1000 kVA U _{sc} = 5 % P _{cu} = 13.3 x 10 ³ watts	2.35	8.5			
Single-core cables 5 m copper 4 x 240 mm ² /phase	$R_c = \frac{18.51}{4} \times \frac{5}{240} = 0.10$	X _c = 0.08 x 5 = 0.40	2.48	9.25	I _{sc1} = 25 kA
Main circuit breaker	Not considered in practice				
Busbars 10 m	Not considered in practice				
Three-core cable 100 m 95 mm ² copper	$R_c = 18.51 \times \frac{100}{95} = 19.5$	X _c = 100 x 0.08 = 8	22	17.3	I _{sc3} = 8.7 kA
Three-core cable 20 m 10 mm ² copper final circuits	$R_c = 18.51 \times \frac{20}{10} = 37$	X _c = 20 x 0.08 = 1.6	59	18.9	I _{sc4} = 3.9 kA

RT : Total resistance. XT: Total reactance. I_{sc} : 3-phase maximum short-circuit current
Calculations made as described in figure G36

Fig. G40 Example of maximum short-circuit calculations for a LV installation supplied at 400 V (nominal) from a 1000 kVA MV/LV transformer

4.3 I_{sc} at the receiving end of a feeder as a function of the I_{sc} at its sending end

The network shown in Fig. G41 typifies a case for the application of Fig. G42 next page, derived by the «method of composition» (mentioned in Chapter F Sub-clause 6.2). These tables give a rapid and sufficiently accurate value of short-circuit current at a point in a network, knowing:

- The value of short-circuit current upstream of the point considered
 - The length and composition of the circuit between the point at which the short-circuit current level is known, and the point at which the level is to be determined
- It is then sufficient to select a circuit breaker with an appropriate short-circuit fault rating immediately above that indicated in the tables.

If more precise values are required, it is possible to make a detailed calculation (see Sub-Clause 4.2) or to use a software package, such as Ecodial. In such a case, moreover, the possibility of using the cascading technique should be considered, in which the use of a current limiting circuit breaker at the upstream position would allow all circuit breakers downstream of the limiter to have a short-circuit current rating much lower than would otherwise be necessary (See chapter H Sub-Clause 4.5).

Method

Select the c.s.a. of the conductor in the column for copper conductors (in this example the c.s.a. is 50 mm²).

Search along the row corresponding to 50 mm² for the length of conductor equal to that of the circuit concerned (or the nearest possible on the low side). Descend vertically the column in which the length is located, and stop at a row in the middle section (of the 3 sections of the Figure) corresponding to the known fault-current level (or the nearest to it on the high side).

In this case 30 kA is the nearest to 28 kA on the high side. The value of short-circuit current at the downstream end of the 20 metre circuit is given at the intersection of the vertical column in which the length is located, and the horizontal row corresponding to the upstream I_{sc} (or nearest to it on the high side).

This value in the example is seen to be 14.7 kA.

The procedure for aluminium conductors is similar, but the vertical column must be ascended into the middle section of the table.

In consequence, a DIN-rail-mounted circuit breaker rated at 63 A and I_{sc} of 25 kA (such as a NG125N unit) can be used for the 55 A circuit in Fig. G41.

A Compact rated at 160 A with an I_{sc} capacity of 25 kA (such as a NSX160 unit) can be used to protect the 160 A circuit.

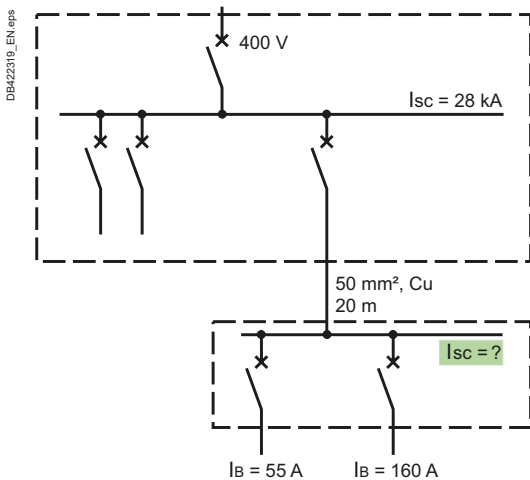


Fig. G41 Determination of downstream short-circuit current level I_{sc} using Fig. G40

4 Short-circuit current

در صفحات 186 و 187 این هندبوک مقادیر حداکثر طول کابل برای اطمینان از قطع حداقل جریان اتصال کوتاه گفته شده است

Copper 230 V / 400 V																						
c.s.a. of phase conductors (mm ²)	Length of circuit (in metres)																					
1.5																						
2.5																						
4																						
6																						
10																						
16																						
25																						
35																						
50 [a]																						
70																						
95																						
120																						
150																						
185																						
240																						
300																						
2x120																						
2x150																						
2x185																						
55x120																						
3x150																						
3x185																						
Isc upstream (in kA)	Isc downstream (in kA)																					
100	93	90	87	82	77	70	62	54	45	37	29	22	17.0	12.6	9.3	6.7	4.9	3.5	2.5	1.8	1.3	0.9
90	84	82	79	75	71	65	58	51	43	35	28	22	16.7	12.5	9.2	6.7	4.8	3.5	2.5	1.8	1.3	0.9
80	75	74	71	68	64	59	54	47	40	34	27	21	16.3	12.2	9.1	6.6	4.8	3.5	2.5	1.8	1.3	0.9
70	66	65	63	61	58	54	49	44	38	32	26	20	15.8	12.0	8.9	6.6	4.8	3.4	2.5	1.8	1.3	0.9
60	57	56	55	53	51	48	44	39	35	29	24	20	15.2	11.6	8.7	6.5	4.7	3.4	2.5	1.8	1.3	0.9
50	48	47	46	45	43	41	38	35	31	27	22	18.3	14.5	11.2	8.5	6.3	4.6	3.4	2.4	1.7	1.2	0.9
40	39	38	38	37	36	34	32	30	27	24	20	16.8	13.5	10.6	8.1	6.1	4.5	3.3	2.4	1.7	1.2	0.9
35	34	34	33	33	32	30	29	27	24	22	18.8	15.8	12.9	10.2	7.9	6.0	4.5	3.3	2.4	1.7	1.2	0.9
30	29	29	29	28	27	27	25	24	22	20	17.3	14.7	12.2	9.8	7.6	5.8	4.4	3.2	2.4	1.7	1.2	0.9
25	25	24	24	24	23	23	22	21	19.1	17.4	15.5	13.4	11.2	9.2	7.3	5.6	4.2	3.2	2.3	1.7	1.2	0.9
20	20	20	19.4	19.2	18.8	18.4	17.8	17.0	16.1	14.9	13.4	11.8	10.1	8.4	6.8	5.3	4.1	3.1	2.3	1.7	1.2	0.9
15	14.8	14.8	14.7	14.5	14.3	14.1	13.7	13.3	12.7	11.9	11.0	9.9	8.7	7.4	6.1	4.9	3.8	2.9	2.2	1.6	1.2	0.9
10	9.9	9.9	9.8	9.8	9.7	9.6	9.4	9.2	8.9	8.5	8.0	7.4	6.7	5.9	5.1	4.2	3.4	2.7	2.0	1.5	1.1	0.9
7	7.0	6.9	6.9	6.9	6.9	6.8	6.7	6.6	6.4	6.2	6.0	5.6	5.2	4.7	4.2	3.6	3.0	2.4	1.9	1.4	1.1	0.9
5	5.0	5.0	5.0	4.9	4.9	4.9	4.9	4.8	4.7	4.6	4.5	4.3	4.0	3.7	3.4	3.0	2.5	2.1	1.7	1.3	1.0	0.9
4	4.0	4.0	4.0	4.0	4.0	3.9	3.9	3.9	3.8	3.7	3.6	3.5	3.3	3.1	2.9	2.6	2.2	1.9	1.6	1.2	1.0	0.7
3	3.0	3.0	3.0	3.0	3.0	3.0	2.9	2.9	2.9	2.9	2.8	2.7	2.6	2.5	2.3	2.1	1.9	1.6	1.4	1.1	0.9	0.7
2	2.0	2.0	2.0	2.0	2.0	2.0	2.0	2.0	2.0	2.0	1.9	1.9	1.9	1.8	1.7	1.6	1.4	1.3	1.1	1.0	0.8	0.6
1	1.0	1.0	1.0	1.0	1.0	1.0	1.0	1.0	1.0	1.0	1.0	1.0	1.0	0.9	0.9	0.9	0.8	0.8	0.7	0.6	0.6	0.5
Aluminium 230 V / 400 V																						
c.s.a. of phase conductors (mm ²)	Length of circuit (in metres)																					
2.5																						
4																						
6																						
10																						
16																						
25																						
35																						
50 [a]																						
70																						
95																						
120																						
150																						
185																						
240																						
300																						
2x120																						
2x150																						
2x185																						
2x240																						
3x120																						
3x150																						
3x185																						
3x240																						

[a] for 50 mm² cables, the actual cross-section used for calculation is 47.5 mm². For more information, see note in Fig. G53

Note: for a 3-phase system having 230 V between phases, divide the above lengths by $\sqrt{3}$.

Fig. G42 Isc at a point downstream, as a function of a known upstream fault-current value and the length and c.s.a. of the intervening conductors, in a 230/400 V 3-phase system

4.4 Short-circuit current supplied by a generator or an inverter: Please refer to Chapter N

5 Particular cases of short-circuit current

If a protective device in a circuit is intended only to protect against short-circuit faults, it is essential that it will operate with certainty at the lowest possible level of short-circuit current that can occur on the circuit

5.1 Calculation of minimum levels of short-circuit current

In general, on LV circuits, a single protective device protects against all levels of current, from the overload threshold through the maximum rated short-circuit current breaking capability of the device. The protection device should be able to operate in a maximum time to ensure people and circuit safety, for all short-circuit current or fault current that may occur. To check that behavior, calculation of minimal short-circuit current or fault current is mandatory.

In addition, in certain cases overload protective devices and separate short-circuit protective devices are used.

Examples of such arrangements

Fig. G43 to Fig. G45 show some common arrangements where overload and short-circuit protections are achieved by separate devices.

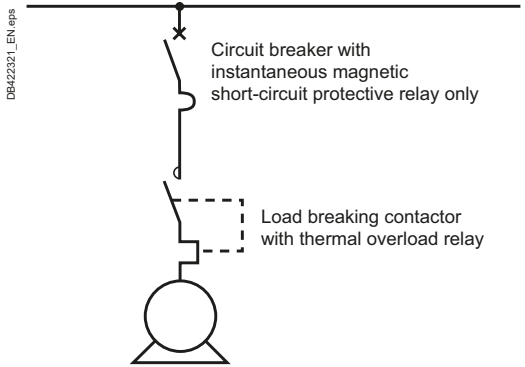


Fig. G44 Circuit protected by circuit breaker without thermal overload relay

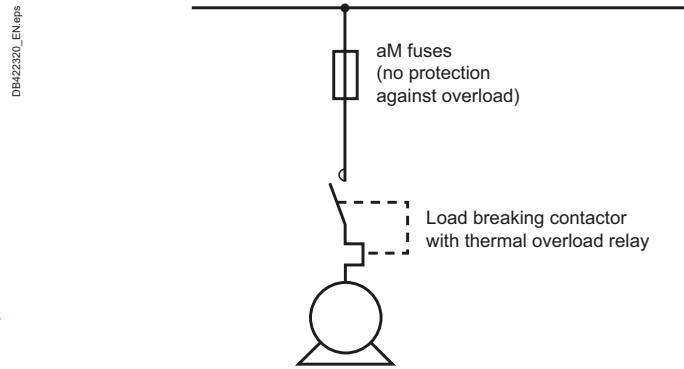


Fig. G43 Circuit protected by aM fuses

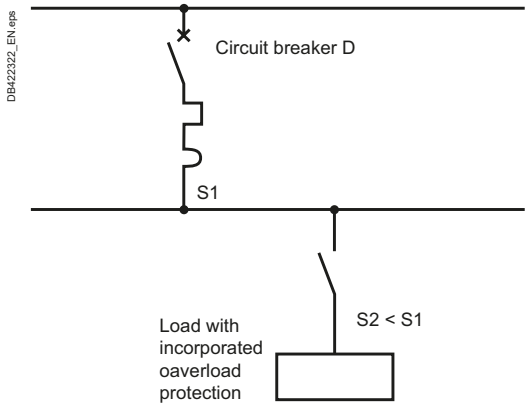


Fig. G45 Circuit breaker D provides protection against short-circuit faults as far as and including the load

As shown in Fig. G43 and Fig. G44, the most common circuits using separate devices control and protect motors.

Fig. G45 constitutes a derogation to the basic protection rules, and is generally used on circuits of busways (busbar trunking systems), lighting rails, etc.

Variable speed drive

Fig. G46 shows the functions provided by the variable speed drive, and if necessary some additional functions provided by devices such as circuit breaker, thermal relay, RCD.

Protection to be provided	Protection generally provided by the variable speed drive	Additional protection if not provided by the variable speed drive
Cable overload	Yes	CB / Thermal relay
Motor overload	Yes	CB / Thermal relay
Downstream short-circuit	Yes	
Variable speed drive overload	Yes	
Oversvoltage	Yes	
Undersvoltage	Yes	
Loss of phase	Yes	
Upstream short-circuit		Circuit breaker (short-circuit tripping)
Internal fault		Circuit breaker (short-circuit and overload tripping)
Downstream earth fault (indirect contact)	(self protection)	RCD ≥ 300 mA or CB in TN earthing system
Direct contact fault		RCD ≤ 30 mA

Fig. G46 Protection to be provided for variable speed drive applications

5 Particular cases of short-circuit current

The protective device must fulfill:

- instantaneous trip setting $I_m < I_{sc_{min}}$ for a circuit breaker
- fusion current $I_a < I_{sc_{min}}$ for a fuse

Conditions to be fulfilled

The protective device must therefore satisfy the two following conditions:

- Its breaking capacity must be greater than I_{sc} , the 3-phase short-circuit current at its point of installation
- Elimination of the minimum short-circuit current possible in the circuit, in a time t_c compatible with the thermal constraints of the circuit conductors, where:

$$t_c \leq \frac{k^2 S^2}{I_{sc_{min}}^2} \quad (\text{valid for } t_c < 5 \text{ seconds})$$

where S is the cross section area of the cable, k is a factor depending of the cable conductor material, the insulation material and initial temperature.

Example: for copper XLPE, initial temperature 90 °C, $k = 143$ (see IEC60364-4-43 §434.3.2 table 43A and Fig. G52).

Comparison of the tripping or fusing performance curve of protective devices, with the limit curves of thermal constraint for a conductor shows that this condition is satisfied if:

- $I_{sc}(\text{min}) > I_m$ (instantaneous or short time delay circuit breaker trip setting current level), (see Fig. G47)
- $I_{sc}(\text{min}) > I_a$ for protection by fuses. The value of the current I_a corresponds to the crossing point of the fuse curve and the cable thermal withstand curve (see Fig. G48 and Fig. G49).

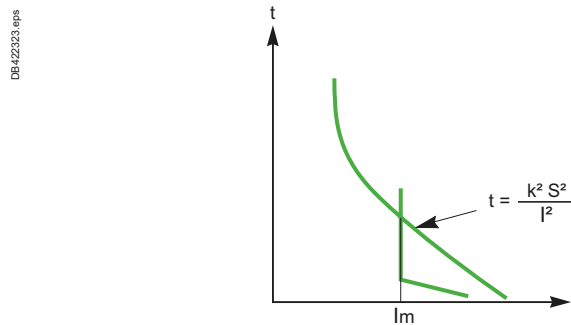


Fig. G47 Protection by circuit breaker

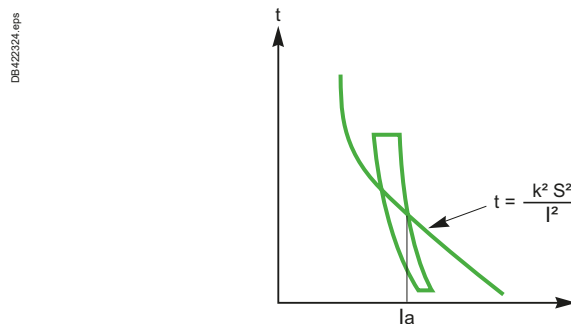


Fig. G48 Protection by aM-type fuses

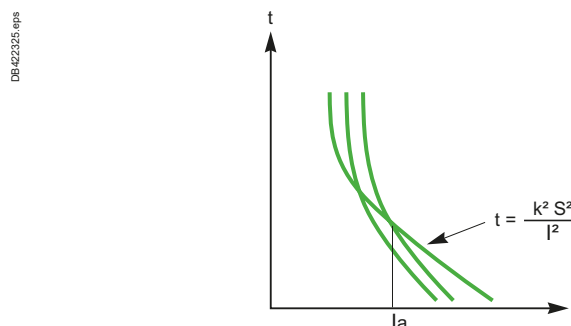


Fig. G49 Protection by gG-type fuses

5 Particular cases of short-circuit current

In practice this means that the length of circuit downstream of the protective device must not exceed a calculated maximum length:

$$L_{max} = \frac{0.8 U S_{ph}}{2 \rho I_m}$$

Practical method of calculating Lmax

The limiting effect of the impedance of long circuit conductors on the value of short-circuit currents must be checked and the length of a circuit must be restricted accordingly.

For protection of people (fault protection or indirect contacts), the method to calculate the maximum circuit length for TN system and IT system (second fault) is presented in Chapter F Sub-clauses 5.3 and 6.3.

Two other cases are considered below, for phase-to-phase and phase-to-neutral short-circuits.

1 - Calculation of Lmax for a 3-phase 3-wire circuit

The minimum short-circuit current will occur when two phase wires are short-circuited at the remote end of the circuit (see Fig. G50).

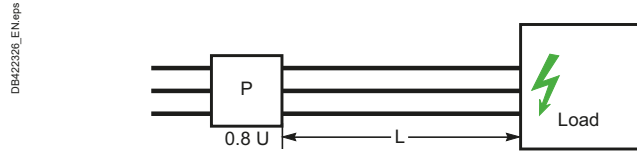


Fig. G50 Definition of L for a 3-phase 3-wire circuit

Using the “conventional method”, the voltage at the point of protection P is assumed to be 80 % of the nominal voltage during a short-circuit fault, so that 0.8 U = I_{sc} Z_d, where:

Z_d = impedance of the fault loop

I_{sc} = short-circuit current (ph/ph)

U = phase-to-phase nominal voltage

For cables ≤ 120 mm², reactance may be neglected, so that Z_d = ρ $\frac{2L}{S_{ph}}$ [1]

where:

ρ = resistivity of conductor material at the average temperature during a short-circuit,

S_{ph} = c.s.a. of a phase conductor in mm²

L = length in metres

The condition for the cable protection is I_m ≤ I_{sc} with I_m = trip current which guarantees instantaneous operation of the circuit breaker.

This leads to I_m ≤ $\frac{0.8 U}{Z_d}$ which gives L ≤ $\frac{0.8 U S_{ph}}{2 \rho I_m}$

For conductors of similar nature, U and ρ are constants (U = 400 V for phase-to-phase fault, ρ = 0.023 Ω.mm²/m [2] for copper conductors), so the upper formula can be written as:

$$L_{max} = \frac{k S_{ph}}{I_m}$$

with L_{max} = maximum circuit length in metres

For industrial circuit breakers (IEC 60947-2), the value of I_m is given with ±20% tolerance, so L_{max} should be calculated for I_m+20% (worst case).

k factor values are provided in the following table, for copper cables, taking into account these 20%, and as a function of cross-section for S_{ph} > 120 mm² [1]

Cross-section (mm ²)	≤ 120	150	185	240	300
k (for 400 V)	5800	5040	4830	4640	4460

2 - Calculation of Lmax for a 3-phase 4-wire 230/400 V circuit

The minimum I_{sc} will occur when the short-circuit is between a phase conductor and the neutral at the end of the circuit.

A calculation similar to that of example 1 above is required, but for a single-phase fault (230V).

■ If S_n (neutral cross-section) = S_{ph}

L_{max} = k S_{ph} / I_m with k calculated for 230V, as shown in the table below

Cross-section (mm ²)	≤ 120	150	185	240	300
k (for 230 V)	3333	2898	2777	2668	2565

■ If S_n (neutral cross-section) < S_{ph}, then (for cable cross-section ≤ 120mm²)

$$L_{max} = 6\,666 \frac{S_{ph}}{I_m} \frac{1}{1+m} \text{ where } m = \frac{S_{ph}}{S_n}$$

[1] For c.s.a. > 120 mm², the resistance calculated for the conductors must be increased to account for the non-uniform current density in the conductor (due to “skin” and “proximity” effects)

Suitable values are as follows:

150 mm²: R + 15 %

185 mm²: R + 20 %

240 mm²: R + 25 %

300 mm²: R + 30 %

[2] Resistivity for copper EPR/XLPE cables when passing short-circuit current, eg for the max temperature they can withstand = 90°C (cf Fig. G37).

5 Particular cases of short-circuit current

Tabulated values for L_{max}

Based on the practical calculation method detailed in previous paragraph, pre-calculated tables can be prepared.

In practice, the tables **Fig. F25** to **Fig. F28** already used in chapter F for earth-fault calculation can also be used here, but applying the correction factors in **Fig. G51** below, to obtain L_{max} value related to phase-to-phase or phase-to-neutral short-circuits.

Note: for aluminium conductors, the lengths obtained must be multiplied again by 0.62.

Circuit detail		
3-phase 3-wire 400 V circuit or 1-phase 2-wire 400 V circuit (no neutral)		1.73
1-phase 2-wire (phase and neutral) 230 V circuit		1
3-phase 4-wire 230/400 V circuit or 2-phase 3-wire 230/400 V circuit (i.e with neutral)	Sph / S neutral = 1	1
	Sph / S neutral = 2	0.67

Fig. G51 Correction factor to apply to lengths obtained from **Fig. F25** to **Fig. F28**, to obtain L_{max} considering phase-to-phase or phase-to-neutral short-circuits

Examples

Example 1

In a 3-phase 3-wire 400 V installation the short-circuit protection of a 22 kW (50 A) motor is provided by a magnetic circuit breaker type GV4L, the instantaneous short-circuit current trip is set at 700 A (accuracy of $\pm 20\%$), i.e. in the worst case would require $700 \times 1.2 = 840$ A to trip.

The cable c.s.a. = 10 mm² and the conductor material is copper.

In **Fig. F25** the column I_m = 700 A crosses the row c.s.a. = 10 mm² at the value for L_{max} of 48 m. **Fig. G51** gives a factor 1.73 to apply to this value for 3-phase 3-wire circuit (no neutral). The circuit breaker protects the cable against short-circuit faults, therefore, provided that its length does not exceed $48 \times 1.73 = 83$ metres.

Example 2

In a 3L+N 400 V circuit, the protection is provided by a 220 A circuit breaker type NSX250N with micrologic 2 trip unit having instantaneous short-circuit protection set at 3000A ($\pm 20\%$), i.e. a worst case of 3600 A to be certain of tripping.

The cable c.s.a. = 120 mm² and the conductor material is aluminium.

In **Fig. F25** the column I_m = 3200 A (first value > 3000 A, as the table already includes the +20% on I_m in its calculation) crosses the row c.s.a. = 120 mm² at the value for L_{max} of 125 m. Being a 3-phase 4-wire 400 V circuit (with neutral), the correction factor from **Fig. G51** to apply is 1. In complement, as the conductor is aluminium, a factor of 0.62 has to be applied.

The circuit breaker will therefore protect the cable against short-circuit current, provided that its length does not exceed $125 \times 0.62 = 77$ metres.

5 Particular cases of short-circuit current

In general, verification of the thermal-withstand capability of a cable is not necessary, except in cases where cables of small c.s.a. are installed close to, or feeding directly from, the main general distribution board

5.2 Verification of the withstand capabilities of cables under short-circuit conditions

Thermal constraints

When the duration of short-circuit current is brief (several tenths of a second up to five seconds maximum) all of the heat produced is assumed to remain in the conductor, causing its temperature to rise. The heating process is said to be adiabatic, an assumption that simplifies the calculation and gives a pessimistic result, i.e. a higher conductor temperature than that which would actually occur, since in practice, some heat would leave the conductor and pass into the insulation.

For a period of 5 seconds or less, the relationship $I^2t = k^2S^2$ characterizes the time in seconds during which a conductor of c.s.a. S (in mm^2) can be allowed to carry a current I , before its temperature reaches a level which would damage the surrounding insulation.

The factor k is given in Fig. G52 below.

	Conductor insulation			
	PVC $\leq 300 \text{ mm}^2$	PVC $> 300 \text{ mm}^2$	EPR XLPE	Rubber 60 °C
Initial temperature °C	70	70	90	60
Final temperature °C	160	140	250	200
Conductor material	Copper	115	103	143
	Aluminium	76	68	94

Fig. G52 Value of the constant k according to table 43A of IEC 60364-4-43

The method of verification consists in checking that the thermal energy I^2t per ohm of conductor material, allowed to pass by the protecting circuit breaker (from manufacturers catalogues) is less than that permitted for the particular conductor (as given in Fig. G53 below).

S (mm^2)	PVC		XLPE	
	Copper	Aluminium	Copper	Aluminium
1.5	0.0297	0.0130	0.0460	0.0199
2.5	0.0826	0.0361	0.1278	0.0552
4	0.2116	0.0924	0.3272	0.1414
6	0.4761	0.2079	0.7362	0.3181
10	1.3225	0.5776	2.0450	0.8836
16	3.3856	1.4786	5.2350	2.2620
25	8.2656	3.6100	12.7806	5.5225
35	16.2006	7.0756	25.0500	10.824
50 [a]	29.839	13.032	46.133	19.936

[a] For 50 mm^2 cables, the actual cross-section used for calculation is 47.5 mm^2 [1].

Fig. G53 Maximum allowable thermal stress for cables I^2t (expressed in ampere² x second x 10⁶)

Example

Is a copper-cored XLPE cable of 4 mm^2 c.s.a. adequately protected by a iC60N circuit breaker? (see Fig. G54)

Fig. G53 shows that the I^2t value for the cable is 0.3272 x 10⁶, while the maximum "let-through" value by the circuit breaker, as given in the manufacturer's catalogue, is considerably less (< 0.1.10⁶ A²s).

The cable is therefore adequately protected by the circuit breaker up to its full rated breaking capability.

[1] In fact, the cable (maximum) resistance values that should be used for precise calculation are the ones given by the IEC 60228 "conductors of insulated cables" standard. Calculation of cable resistance with the formula $R = \rho L / S$, as used for this table, provides values that are sufficiently close to these values (in the order of 1%), except for 50 mm^2 cables for which a "theoretical" cross-section of 47.5 mm^2 should be used.

5 Particular cases of short-circuit current

Electrodynamic constraints

For all type of circuit (conductors or bus-trunking), it is necessary to take electrodynamic effects into account.

To withstand the electrodynamic constraints, the conductors must be solidly fixed and the connections must be strongly tightened, making traditional cable installations withstand level directly depending on the quality of the work executed by the electrical contractor.

For busways (busbar trunking systems), rails, etc. it is also necessary to verify that they will withstand the electrodynamic constraints during a short-circuit. But for busways the electrodynamic withstand performance is defined by construction, and verified by type tests according to IEC 61439-6, with a specified overcurrent protective device.

Manufacturers like Schneider Electric provide [ready-to-use coordination tables between their circuit breakers](#) and their busways, making it quick and easy to select the optimal solution that guarantees the withstand strength of the system.

G34

Type of Canalis busbar trunking KSA100							
Isc max. in kA rms		25 kA	36 kA	50 kA			
Type of circuit breaker	NG125	NG125N100	NG125H80	NG125L 80			
	Compact NSXm	NSXm B/F/N/H 100	NSXm F/N/H 100				
	Compact NSX	NSX100B/F/N/H/S/L					

Type of Canalis busbar trunking KSA160							
Isc max. in kA rms		25 kA	36 kA	50 kA	70 kA	90 kA	
Type of circuit breaker	Compact NSXm	NSXm B/F/N/H 160	NSXm F/N/H 160	NSXm N/H 160	NSXm H 160		
	Compact NSX	NSX100B/F/N/H/S/L	NSX100F/N/H/S/L	NSX100N/H/S/L	NSX100H/S/L	NSX100S/L	
		NSX160B/F/N/H/S/L	NSX160F/N/H/S/L	NSX160N/H/S/L	NSX160H/S/L		
		NSX250B/F/N/H/S/L	NSX250F/N/H/S/L	NSX250N/H/S/L			

Type of Canalis busbar trunking KSA250							
Isc max. in kA rms		25 kA	36 kA	50 kA	70 kA	100 kA	150 kA
Type of circuit breaker	Compact NSX	NSX160B/F/N/H/S/L	NSX160F/N/H/S/L	NSX160N/H/S/L	NSX160H/S/L	NSX160S/L	NSX160L
		NSX250B/F/N/H/S/L	NSX250F/N/H/S/L	NSX250N/H/S/L	NSX250H/S/L	NSX250S/L	NSX250L
		NSX400F/N/H/S/L	NSX400N/H/S/L				
	Compact NS	NS630b N/H/L/LB	NS630b L/LB	NS630b L/LB	NS630b LB		

Type of Canalis busbar trunking KSA400							
Isc max. in kA rms		25 kA	36 kA	50 kA	70 kA	100 kA	150 kA
Type of circuit breaker	Compact NSX	NSX250B/F/N/H/S/L	NSX250F/N/H/S/L	NSX250N/H/S/L	NSX250H/S/L	NSX250S/L	NSX250L
		NSX400F/N/H/S/L	NSX400F/N/H/S/L	NSX400N/H/S/L	NSX400H/S/L	NSX400S/L	NSX400L
		NSX630F/N/H/S/L	NSX630F/N/H/S/L	NSX630N/H/S/L	NSX630H/S/L	NSX630S/L	NSX630L
	Compact NS	NS630b N/H/L/LB	NS630b L/LB	NS630b L/LB	NS630b LB		

Type of Canalis busbar trunking KSA500							
Isc max. in kA rms		25 kA	36 kA	50 kA	70 kA	100 kA	150 kA
Type of circuit breaker	Compact NSX	NSX400F/N/H/S/L	NSX400F/N/H/S/L	NSX400N/H/S/L	NSX400H/S/L	NSX400S/L	NSX400L
		NSX630F/N/H/S/L	NSX630F/N/H/S/L	NSX630N/H/S/L	NSX630H/S/L	NSX630S/L	NSX630L
	Compact NS	NS630b N/H/L/LB		NS630b L / LB		NS630b LB	

Type of Canalis busbar trunking KSA630							
Isc max. in kA rms		≤ 32 kA	36 kA	50 kA	70 kA	100 kA	150 kA
Type of circuit breaker	Compact NSX	NSX400F/N/H/S/L		NSX400N/H/S/L	NSX400H/S/L	NSX400S/L	NSX400L
		NSX630F/N/H/S/L		NSX630N/H/S/L	NSX630H/S/L	NSX630S/L	NSX630L
	Compact NS	NS630b N/H/L/LB		NS630b L/LB			NS630b LB
Masterpact MTZ1		NS800N/H/L/LB		NS800L/LB			NS800LB
	MTZ1 06 H1/H2/H3/L1			MTZ1 06 L1			
		MTZ1 08 H1/H2/H3/L1		MTZ1 08 L1			

Fig. G54 Example of coordination table between circuit-breakers and busways (Schneider Electric)

6 Protective earthing conductor (PE)

6.1 Connection and choice

Protective (PE) conductors provide the bonding connection between all exposed and extraneous conductive parts of an installation, to create the main equipotential bonding system. These conductors conduct fault current due to insulation failure (between a phase conductor and an exposed conductive part) to the earthed neutral of the source. PE conductors are connected to the main earthing terminal of the installation.

The main earthing terminal is connected to the earthing electrode (see Chapter E) by the earthing conductor (grounding electrode conductor in the USA).

PE conductors must be:

- Insulated and coloured yellow and green (stripes)
- Protected against mechanical and chemical damage.

In IT and TN-earthed schemes it is strongly recommended that PE conductors should be installed in close proximity (i.e. in the same conduits, on the same cable tray, etc.) as the live cables of the related circuit. This arrangement ensures the minimum possible inductive reactance in the earth-fault current carrying circuits.

It should be noted that this arrangement is provided by construction for busways (busbar trunking systems).

Connection

PE conductors must:

- Not include any means of breaking the continuity of the circuit (such as a switch, removable links, etc.)
- Connect exposed conductive parts individually to the main PE conductor, i.e. in parallel, not in series, as shown in Fig. G55
- Have an individual terminal on common earthing bars in distribution boards.

TT scheme

The PE conductor need not necessarily be installed in close proximity to the live conductors of the corresponding circuit, since high values of earth-fault current are not needed to operate the RCD-type of protection used in TT installations.

IT and TN schemes

The PE or PEN conductor, as previously noted, must be installed as close as possible to the corresponding live conductors of the circuit and no ferro-magnetic material must be interposed between them. A PEN conductor must always be connected directly to the earth terminal of an appliance, with a looped connection from the earth terminal to the neutral terminal of the appliance (see Fig. G56).

- TN-C scheme (the neutral and PE conductor are one and the same, referred to as a PEN conductor)

The protective function of a PEN conductor has priority, so that all rules governing PE conductors apply strictly to PEN conductors

- TN-C to TN-S transition

The PE conductor for the installation is connected to the PEN terminal or bar (see Fig. G57) generally at the origin of the installation. Downstream of the point of separation, no PE conductor can be connected to the neutral conductor.

DB422328_EN.eps

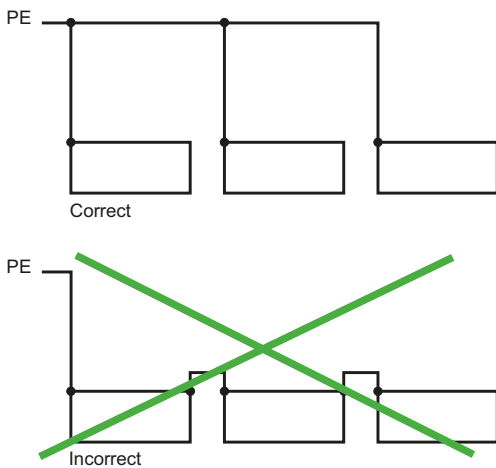


Fig. G55 A poor connection in a series arrangement will leave all downstream appliances unprotected

DB422329.eps

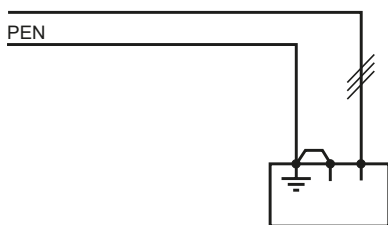


Fig. G56 Direct connection of the PEN conductor to the earth terminal of an appliance

DB422330.eps



Fig. G57 The TN-C-S scheme

6 Protective earthing conductor (PE)

Types of materials

Materials of the kinds mentioned below in Fig. G58 can be used for PE conductors, provided that the conditions mentioned in the last column are satisfied.

Type of protective earthing conductor (PE)	IT scheme	TN scheme	TT scheme	Conditions to be respected	
Supplementary conductor	In the same cable as the phases, or in the same cable run	Strongly recommended	Strongly recommended	Correct	The PE conductor must be insulated to the same level as the phases
	Independent of the phase conductors	Possible [a]	Possible [a] [b]	Correct	<ul style="list-style-type: none"> The PE conductor may be bare or insulated [b]
Metallic housing of bus-trunking or of other prefabricated prewired ducting [e]	Possible [c]	PE possible [c] PEN possible [h]	Correct	<ul style="list-style-type: none"> The electrical continuity must be assured by protection against deterioration by mechanical, chemical and electrochemical hazards 	
External sheath of extruded, mineral- insulated conductors (e.g. «pyrotenax» type systems)	Possible [c]	PE possible [c] PEN not recommended [b] [c]	Possible	<ul style="list-style-type: none"> Their conductance must be adequate 	
Certain extraneous conductive elements [f] such as: <ul style="list-style-type: none"> Steel building structures Machine frames Water pipes [g] 	Possible [d]	PE possible [d] PEN forbidden	Possible		
Metallic cable ways, such as, conduits [i], ducts, trunking, trays, ladders, and so on...	Possible [d]	PE possible [d] PEN not recommended [b] [d]	Possible		

Forbidden for use as PE conductors, are: metal conduits [i], gas pipes, hot-water pipes, cable-armouring tapes [i] or wires [i]

[a] In TN and IT schemes, fault clearance is generally achieved by overcurrent devices (fuses or circuit breakers) so that the impedance of the fault-current loop must be sufficiently low to assure positive protective device operation. The surest means of achieving a low loop impedance is to use a supplementary core in the same cable as the circuit conductors (or taking the same route as the circuit conductors). This solution minimizes the inductive reactance and therefore the impedance of the loop.

[b] The PEN conductor is a neutral conductor that is also used as a protective earth conductor. This means that a current may be flowing through it at any time (in the absence of an earth fault). For this reason an insulated conductor is recommended for PEN operation.

[c] The manufacturer provides the necessary values of R and X components of the impedances (phase/PE, phase/PEN) to include in the calculation of the earth-fault loop impedance.

[d] Possible, but not recommended, since the impedance of the earth-fault loop cannot be known at the design stage. Measurements on the completed installation are the only practical means of assuring adequate protection for persons.

[e] It must allow the connection of other PE conductors. **Note:** these elements must carry an individual green/yellow striped visual indication, 15 to 100 mm long (or the letters PE at less than 15 cm from each extremity).

[f] These elements must be demountable only if other means have been provided to ensure uninterrupted continuity of protection.

[g] With the agreement of the appropriate water authorities.

[h] In the prefabricated pre-wired trunking and similar elements, the metallic housing may be used as a PEN conductor, in parallel with the corresponding bar, or other PE conductor in the housing.

[i] Forbidden in some countries only. Universally allowed to be used for supplementary equipotential conductors.

Fig. G58 Choice of protective conductors (PE)

6.2 Conductor sizing

Fig. G59 below is based on IEC 60364-5-54. This table provides two methods of determining the appropriate c.s.a. for both PE or PEN conductors.

	c.s.a. of phase conductors S _{ph} (mm ²)	Minimum c.s.a. of PE conductor (mm ²)	Minimum c.s.a. of PEN conductor (mm ²)	
			Cu	Al
Simplified method [a]	S _{ph} ≤ 16	S _{ph} [b]	S _{ph} [c]	S _{ph} [c]
	16 < S _{ph} ≤ 25	16	16	25
	25 < S _{ph} ≤ 35	S _{ph} / 2	S _{ph} / 2	S _{ph} / 2
	35 < S _{ph} ≤ 50			
	S _{ph} > 50			
Adiabatic method	Any size	S _{PE/PEN} = $\frac{\sqrt{I^2 \cdot t}}{k}$ [c] [d]		

[a] Data valid if the prospective conductor is of the same material as the line conductor. Otherwise, a correction factor must be applied.

[b] When the PE conductor is separated from the circuit phase conductors, the following minimum values must be respected:

- 2.5 mm² if the PE is mechanically protected
- 4 mm² if the PE is not mechanically protected.

[c] For mechanical reasons, a PEN conductor, shall have a cross-sectional area not less than 10 mm² in copper or 16 mm² in aluminium.

[d] Refer to table A.54 of IEC60364-4-54 or Fig. G60 to get values of k factor.

Fig. G59 Minimum cross section area of protective conductors

6 Protective earthing conductor (PE)

The two methods are:

- Adiabatic (which corresponds with that described in IEC 60724)

This method, while being economical and assuring protection of the conductor against overheating, leads to small c.s.a.'s compared to those of the corresponding circuit phase conductors. The result is sometimes incompatible with the necessity in IT and TN schemes to minimize the impedance of the circuit earth-fault loop, to ensure positive operation by instantaneous overcurrent tripping devices. This method is used in practice, therefore, for TT installations, and for dimensioning an earthing conductor [1].

- Simplified

This method is based on PE conductor sizes being related to those of the corresponding circuit phase conductors, assuming that the same conductor material is used in each case.

Thus, in Fig. G59 for:

$$S_{ph} \leq 16 \text{ mm}^2 \quad S_{PE} = S_{ph}$$

$$16 < S_{ph} \leq 35 \text{ mm}^2 \quad S_{PE} = 16 \text{ mm}^2$$

$$S_{ph} > 35 \text{ mm}^2 \quad S_{PE} = \frac{S_{ph}}{2}$$

Note: when, in a TT scheme, the installation earth electrode is beyond the zone of influence of the source earthing electrode, the c.s.a. of the PE conductor can be limited to 25 mm² (for copper) or 35 mm² (for aluminium).

The neutral cannot be used as a PEN conductor unless its c.s.a. is equal to or larger than 10 mm² (copper) or 16 mm² (aluminium).

Moreover, a PEN conductor is not allowed in a flexible cable. Since a PEN conductor functions also as a neutral conductor, its c.s.a. cannot, in any case, be less than that necessary for the neutral, as discussed in Subclause 7.1 of this Chapter.

This c.s.a. cannot be less than that of the phase conductors unless:

- The kVA rating of single-phase loads is less than 10 % of the total kVA load, and
- I_{max} likely to pass through the neutral in normal circumstances, is less than the current permitted for the selected cable size.

Furthermore, protection of the neutral conductor must be assured by the protective devices provided for phase-conductor protection (described in Sub-clause 7.2 of this Chapter).

Values of factor k to be used in the formulae

These values are identical in several national standards, and the temperature rise ranges, together with factor k values and the upper temperature limits for the different classes of insulation, correspond with those published in IEC60364-5-54, Annex A.

The data presented in Fig. G60 are those most commonly needed for LV installation design.

k values	Nature of insulation	
	Polyvinylchloride (PVC)	Cross-linked-polyethylene (XLPE) Ethylene-propylene-rubber (EPR)
Final temperature (°C)	160	250
Initial temperature (°C)	30	30
Insulated conductors not incorporated in cables or bare conductors in contact with cable jackets	Copper	143
	Aluminium	95
	Steel	52
Conductors of a multi-core-cable	Copper	115
	Aluminium	76
		64

Fig. G60 k factor values for LV PE conductors, commonly used in national standards and complying with IEC60364-5-54 Annex A

[1] Grounding electrode conductor

6 Protective earthing conductor (PE)

These conductors must be sized according to national practices

6.3 Protective conductor between MV/LV transformer and the Main Low Voltage Switchboard (MLVS)

All phase and neutral conductors upstream of the main incoming circuit breaker controlling and protecting the MLVS are protected against short-circuit and fault current by devices at the MV side of the transformer. The conductors in question, together with the PE conductor, must be dimensioned accordingly. Dimensioning of the phase and neutral conductors from the transformer is exemplified in Sub-clause 7.5 of this chapter (for circuit C1 of the system illustrated in Fig. G69).

Recommended conductor sizes for bare and insulated PE conductors from the transformer neutral point, shown in Fig. G61, are indicated below in Fig. G62. The kVA rating to consider is the sum of all (if more than one) transformers connected to the MLVS.

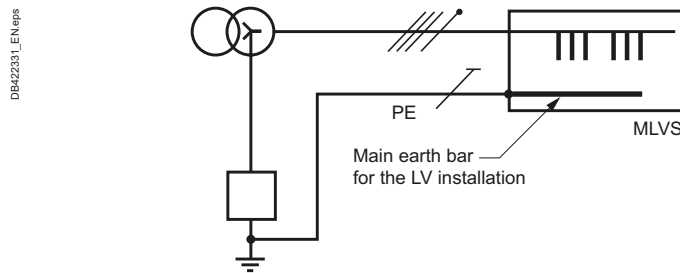


Fig. G61 PE conductor to the main earth bar in the MLVS

The table indicates the c.s.a. of the conductors in mm² according to:

- The nominal rating of the MV/LV transformer(s) in kVA
- The fault-current clearance time by the MV protective devices, in seconds
- The kinds of insulation and conductor materials.

If the MV protection is by fuses, then use the 0.2 seconds columns.

In IT schemes, if an overvoltage protection device is installed (between the transformer neutral point and earth) the conductors for connection of the device should also be dimensioned in the same way as that described above for PE conductors.

Transformer rating in kVA (230/400 V output)	Conductor material	Bare conductors			PVC-insulated conductors			XLPE-insulated conductors		
		c.s.a. of PE conductors SPE (mm ²)								
		0.2	0.5	-	0.2	0.5	-	0.2	0.5	-
≤100	Copper t(s)	25	25	25	25	25	25	25	25	25
160	Aluminium t(s)	-	0.2	0.5	-	0.2	0.5	-	0.2	0.5
200		25	25	35	25	25	50	25	25	35
250		25	35	50	25	35	50	25	25	50
315		25	35	70	35	50	70	25	35	50
400		35	50	70	35	50	95	35	50	70
500		50	70	95	50	70	95	35	50	95
630		50	70	120	70	95	120	50	70	95
800		70	95	150	70	95	150	70	95	120
1000		70	120	150	95	120	185	70	95	150
1250		95	120	185	95	120	185	70	120	150
		95	150	185	120	150	240	95	120	185

Fig. G62 Recommended c.s.a. of PE conductor between the MV/LV transformer and the MLVS, as a function of transformer ratings and fault-clearance times.

This table is the result of the application of the adiabatic method described in 6.2 with:

- i^2 short-circuit level at the transformer LV side,
- t is the tripping time of the MV device for this short circuit current.

6 Protective earthing conductor (PE)

6.4 Equipotential conductor

The main equipotential conductor

This conductor must, in general, have a c.s.a. at least equal to half of that of the largest PE conductor, but in no case need exceed 25 mm² (copper) or 35 mm² (aluminium) while its minimum c.s.a. is 6 mm² (copper) or 10 mm² (aluminium).

Supplementary equipotential conductor

This conductor allows an exposed conductive part which is remote from the nearest main equipotential conductor (PE conductor) to be connected to a local protective conductor. Its c.s.a. must be at least half of that of the protective conductor to which it is connected.

If it connects two exposed conductive parts (M1 and M2 in Fig. G63) its c.s.a. must be at least equal to that of the smaller of the two PE conductors (for M1 and M2). Equipotential conductors which are not incorporated in a cable, should be protected mechanically by conduits, ducting, etc. wherever possible.

Other important uses for supplementary equipotential conductors concern the reduction of the earth-fault loop impedance, particularly for fault protection (indirect contact protection) schemes in TN- or IT-earthed installations, and in special locations with increased electrical risk (refer to IEC 60364-4-41).

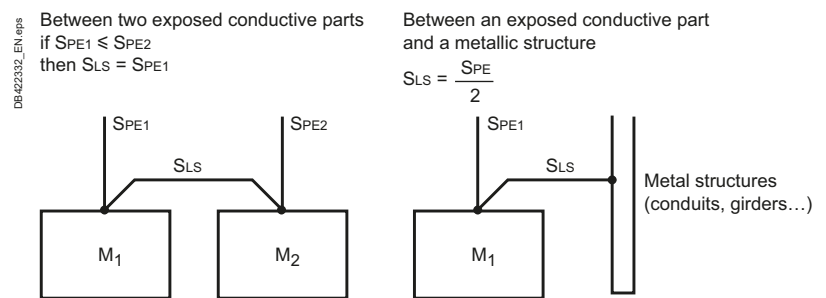


Fig. G63 Supplementary equipotential conductors

7 The neutral conductor

The c.s.a. and the protection of the neutral conductor, apart from its current-carrying requirement, depend on several factors, namely:

- The type of earthing system, TT, TN, etc.
- The harmonic currents
- The method of protection against indirect contact hazards according to the methods described below.

The color of the neutral conductor is statutorily blue. PEN conductor, when insulated, shall be marked by one of the following methods :

- Green-and-yellow throughout its length with, in addition, light blue markings at the terminations, or
- Light blue throughout its length with, in addition, green-and-yellow markings at the terminations.

7.1 Sizing the neutral conductor

Influence of the type of earthing system

TT and TN-S schemes

■ Single-phase circuits or those of c.s.a. $\leq 16 \text{ mm}^2$ (copper) 25 mm^2 (aluminium): the c.s.a. of the neutral conductor must be equal to that of the phases

■ Three-phase circuits of c.s.a. $> 16 \text{ mm}^2$ copper or 25 mm^2 aluminium: the c.s.a. of the neutral may be chosen to be:

- Equal to that of the phase conductors, or
- Smaller, on condition that:

- The current likely to flow through the neutral in normal conditions is less than the permitted value I_z . The influence of triplen^[1] harmonics must be given particular consideration or

- The neutral conductor is protected against short-circuit, in accordance with the following Sub-clause G-7.2

- The size of the neutral conductor is at least equal to 16 mm^2 in copper or 25 mm^2 in aluminium.

TN-C scheme

The same conditions apply in theory as those mentioned above, but in practice, the neutral conductor must not be open-circuited under any circumstances since it constitutes a PE as well as a neutral conductor (see Fig. G59 "c.s.a. of PEN conductor" column).

IT scheme

In general, it is not recommended to distribute the neutral conductor, i.e. a 3-phase 3-wire scheme is preferred. When a 3-phase 4-wire installation is necessary, however, the conditions described above for TT and TN-S schemes are applicable.

Influence of harmonic currents

Effects of triplen harmonics

Harmonics are generated by the non-linear loads of the installation (computers, fluorescent lighting, LED lighting, rectifiers, power electronic choppers) and can produce high currents in the Neutral. In particular triplen harmonics of the three Phases have a tendency to cumulate in the Neutral as:

- Fundamental currents are out-of-phase by $2\pi/3$ so that their sum is zero
- On the other hand, triplen harmonics of the three Phases are always positioned in the same manner with respect to their own fundamental, and are in phase with each other (see Fig. G64).

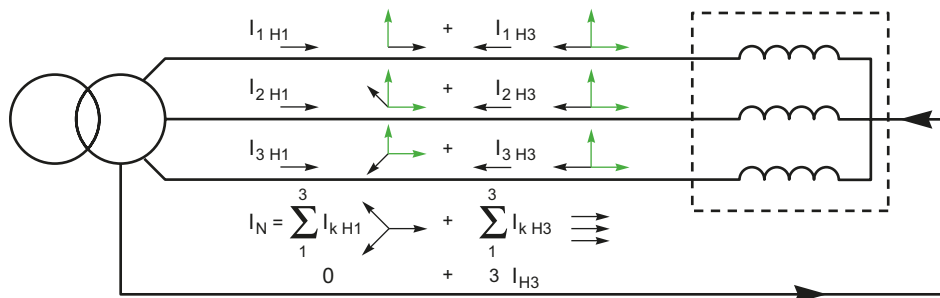


Fig. G64 Triplen harmonics are in phase and cumulate in the Neutral

[1] Harmonics of order 3 and multiple of 3

7 The neutral conductor

Fig. G65 shows the load factor of the neutral conductor as a function of the percentage of 3rd harmonic.

In practice, this maximum load factor cannot exceed $\sqrt{3}$.

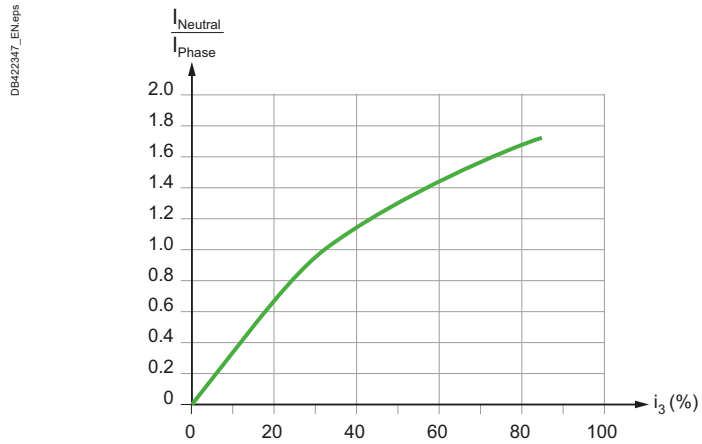


Fig. G65 Load factor of the neutral conductor vs the percentage of 3rd harmonic

Reduction factors for harmonic currents in four-core and five-core cables with four cores carrying current

The basic calculation of a cable concerns only cables with three loaded conductors i.e there is no current in the neutral conductor. Because of the third harmonic current, there is a current in the neutral. As a result, this neutral current creates an hot environment for the 3 phase conductors and for this reason, a reduction factor for phase conductors is necessary (see **Fig. G67**).

Reduction factors, applied to the current-carrying capacity of a cable with three loaded conductors, give the current-carrying capacity of a cable with four loaded conductors, where the current in the fourth conductor is due to harmonics. The reduction factors also take the heating effect of the harmonic current in the phase conductors into account.

- Where the neutral current is expected to be higher than the phase current, then the cable size should be selected on the basis of the neutral current
- Where the cable size selection is based on a neutral current which is not significantly higher than the phase current, it is necessary to reduce the tabulated current carrying capacity for three loaded conductors
- If the neutral current is more than 135 % of the phase current and the cable size is selected on the basis of the neutral current then the three phase conductors will not be fully loaded. The reduction in heat generated by the phase conductors offsets the heat generated by the neutral conductor to the extent that it is not necessary to apply any reduction factor to the current carrying capacity for three loaded conductors.

■ In order to protect cables, the fuse or circuit breaker has to be sized taking into account the greatest of the values of the line currents (phase or neutral). However, there are special devices (for example the Compact NSX circuit breaker equipped with the OSN tripping unit), that allow the use of a c.s.a. of the phase conductors smaller than the c.s.a. of the neutral conductor. A big economic gain can thus be made.



Fig. G66 Compact NSX100 circuit breaker

Third harmonic content of phase current (%)	Reduction factor	
	Size selection is based on phase current	Size selection is based on neutral current
0 - 15	1.0	-
15 - 33	0.86	-
33 - 45	-	0.86
> 45	-	1.0 [a]

[a] If the neutral current is more than 135 % of the phase current and the cable size is selected on the basis of the neutral current then the three phase conductors will not be fully loaded. The reduction in heat generated by the phase conductors offsets the heat generated by the neutral conductor to the extent that it is not necessary to apply any reduction factor to the current carrying capacity for three loaded conductors.

Fig. G67 Reduction factors for harmonic currents in four-core and five-core cables (according to IEC 60364-5-52)

7 The neutral conductor

Examples

Consider a three-phase circuit with a design load of 37 A to be installed using four-core PVC insulated cable clipped to a wall, installation method C. From **Fig. G2**, a 6 mm² cable with copper conductors has a current-carrying capacity of 40 A and hence is suitable if harmonics are not present in the circuit.

■ If 20 % third harmonic is present, then a reduction factor of 0.86 is applied and the design load becomes: $37/0.86 = 43$ A.

For this load a 10 mm² cable is necessary.

In this case, the use of a special protective device (Compact NSX equipped with the OSN trip unit for instance) would allow the use of a 6 mm² cable for the phases and of 10 mm² for the neutral.

■ If 40 % third harmonic is present, the cable size selection is based on the neutral current which is: $37 \times 0.4 \times 3 = 44.4$ A and a reduction factor of 0.86 is applied, leading to a design load of: $44.4/0.86 = 51.6$ A.

For this load a 10 mm² cable is suitable.

■ If 50 % third harmonic is present, the cable size is again selected on the basis of the neutral current, which is: $37 \times 0.5 \times 3 = 55.5$ A. In this case the rating factor is 1 and a 16 mm² cable is required.

In this case, the use of a special protective device (Compact NSX equipped with the OSN trip for instance) would allow the use of a 6 mm² cable for the phases and of 10 mm² for the neutral.

G42

7.2 Protection of the neutral conductor

(see **Fig. G68** next page)

Protection against overload

If the neutral conductor is correctly sized (including harmonics), no specific protection of the neutral conductor is required because it is protected by the phase protection.

However, in practice, if the c.s.a. of the neutral conductor is lower than the phase c.s.a, a neutral overload protection must be installed.

Protection against short-circuit

If the c.s.a. of the neutral conductor is lower than the c.s.a. of the phase conductor, the neutral conductor must be protected against short-circuit.

If the c.s.a. of the neutral conductor is equal or greater than the c.s.a. of the phase conductor, no specific protection of the neutral conductor is required because it is protected by the phase protection.

7.3 Breaking of the neutral conductor

(see **Fig. G68** next page)

The need to break or not the neutral conductor is related to the protection against indirect contact (fault protection).

In TN-C scheme

The neutral conductor must not be open-circuited under any circumstances since it constitutes a PE as well as a neutral conductor.

In TT, TN-S and IT schemes^[1]

In the event of a fault, the circuit breaker will open all poles, including the neutral pole, i.e. the circuit breaker is omnipolar.

The action can only be achieved with fuses in an indirect way, in which the operation of one or more fuses triggers a mechanical trip-out of all poles of an associated series-connected load-break switch.

7.4 Isolation of the neutral conductor

(see **Fig. G68** next page)

It is considered to be the good practice that every circuit be provided with the means for its isolation.

[1] In some countries the rules applied for TN-S are the same as the rules for TN-C

7 The neutral conductor

	TT	TN-C	TN-S	IT
Single-phase (Phase-Neutral)	<p>or</p>			[b] <p>or</p>
Single-phase (Phase-Phase)	[a] <p>or</p>		[a] <p>or</p>	
Three-phase four wires $S_n \geq u S_{ph}$			[c]	[b] <p>or</p>
Three-phase four wires $S_n < u S_{ph}$				[b] <p>or</p>

[a] Authorized for TT or TN-S systems if a RCD is installed at the origin of the circuit or upstream of it, and if no artificial neutral is distributed downstream of its location.

[b] The neutral overcurrent protection is not necessary:

- If the neutral conductor is protected against short-circuits by a device placed upstream, or,
- If the circuit is protected by a RCD which sensitivity is less than 15 % of the neutral admissible current.

[c] In some countries the rules applied for TN-S are the same than the rules for TN-C

Fig. G68 The various situations in which the neutral conductor may appear

8 Worked example of cable calculation

Worked example of cable calculation (see Fig. G69)

The installation is supplied through a 630 kVA transformer. The process requires a high degree of supply continuity and part of the installation can be supplied by a 250 kVA standby generator. The global earthing system is TN-S, except for the most critical loads supplied by an isolation transformer with a downstream IT configuration.

The single-line diagram is shown in Fig. G69 below. The results of a computer study for the circuit from transformer T1 down to the cable C7 is reproduced on Fig. G70. This study was carried out with Ecodial (a Schneider Electric software).

This is followed by the same calculations carried out by the simplified method described in this guide.

DB431011_LEV.eps

G44

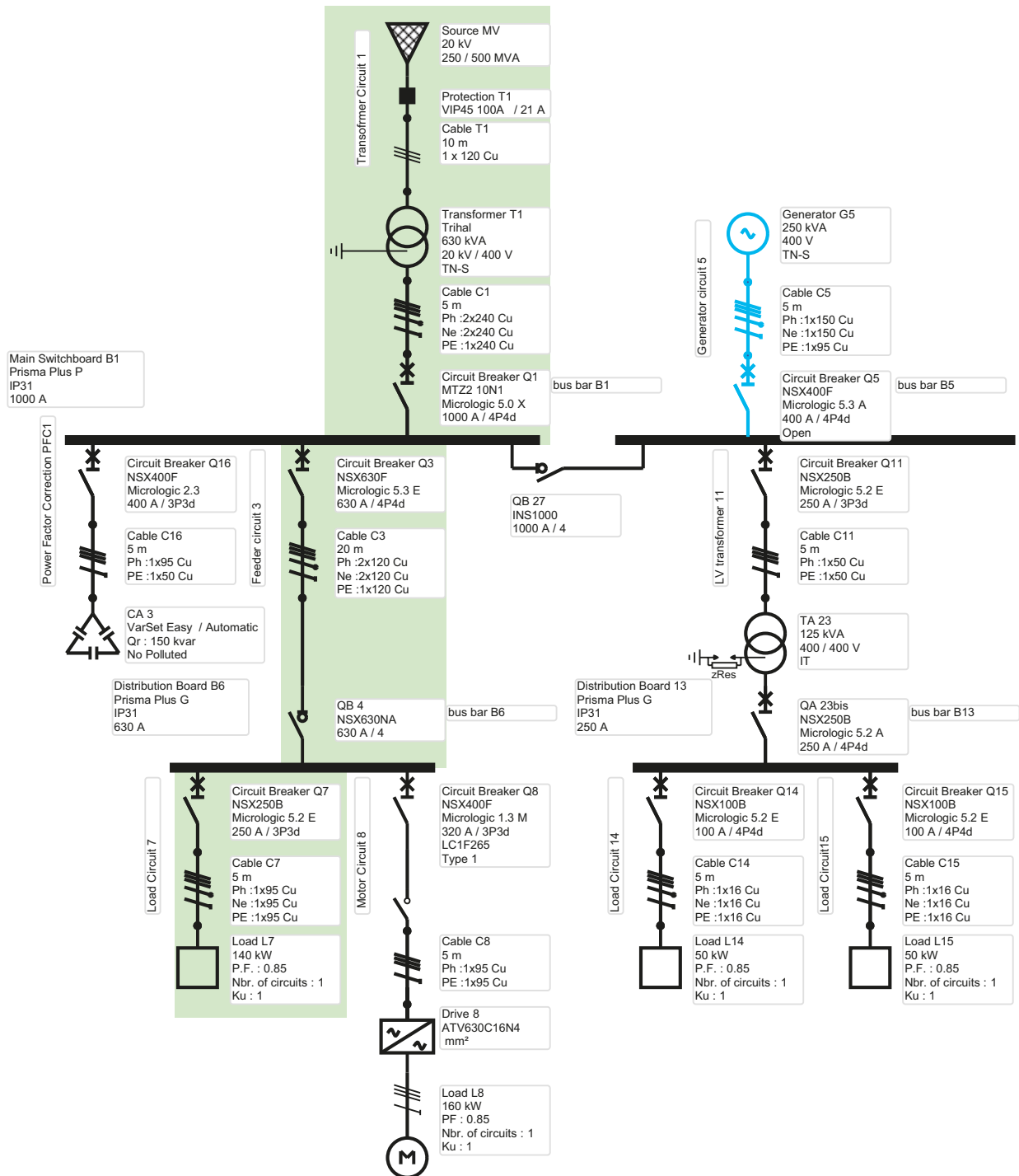


Fig. G69 Example of single-line diagram

8 Worked example of cable calculation

Calculation using software Ecodial

General network characteristics			
Earthing system	TN-S	Number of poles and protected poles	4P4d
Neutral distributed	No	Tripping unit	Micrologic 5.3 E
Voltage (V)	400	Overload trip I _r (A)	518
Frequency (Hz)	50	Short-delay trip I _m / I _{sd} (A)	1036
Upstream fault level (MVA)	500	Cable C3	
Resistance of MV network (mΩ)	0.035	Length	20
Reactance of MV network (mΩ)	0.351	Maximum load current (A)	518
Transformer T1		Type of insulation	PVC
Rating (kVA)	630	Ambient temperature (°C)	30
Short-circuit impedance voltage (%)	4	Conductor material	Copper
Load-losses (P _{krT}) (W)	7100	Single-core or multi-core cable	Single
No-load voltage (V)	420	Installation method	F31
Rated voltage (V)	400	Phase conductor selected csa (mm ²)	2 x 120
Cable C1		Neutral conductor selected csa (mm ²)	2 x 120
Length (m)	5	PE conductor selected csa (mm ²)	1 x 120
Maximum load current (A)	909	Cable voltage drop ΔU (%)	0.459
Type of insulation	PVC	Total voltage drop ΔU (%)	0.583
Ambient temperature (°C)	30	3-phase short-circuit current I _{k3} (kA)	21.5
Conductor material	Copper	1-phase-to-earth fault current I _{ef} (kA)	18
Single-core or multi-core cable	Single	Distribution Board B6	
Installation method	31F	Reference	Prisma Plus G
Number of layers	1	Rated current (A)	630
Phase conductor selected csa (mm ²)	2 x 240	Circuit breaker Q7	
Neutral conductor selected csa (mm ²)	2 x 240	Load current (A)	238
PE conductor selected csa (mm ²)	1 x 240	Type	Compact
Voltage drop ΔU (%)	0.124	Reference	NSX250B
3-phase short-circuit current I _{k3} (kA)	21.5	Rated current (A)	250
Earth fault current I _{ef} (kA)	18	Number of poles and protected poles	3P3d
Circuit breaker Q1		Tripping unit	Micrologic 5.2 E
Load current (A)	909	Overload trip I _r (A)	238
Type	Masterpact	Short-delay trip I _m / I _{sd} (A)	2380
Reference	MTZ2 10N1	Cable C7	
Rated current (A)	1000	Length	5
Number of poles and protected poles	4P4d	Maximum load current (A)	238
Tripping unit	Micrologic 5.0X	Type of insulation	PVC
Overload trip I _r (A)	920	Ambient temperature (°C)	30
Short-delay trip I _m / I _{sd} (A)	9200	Conductor material	Copper
Tripping time t _m (ms)	50	Single-core or multi-core cable	Single
Switchboard B1		Installation method	F31
Reference	Prisma Plus P	Phase conductor selected csa (mm ²)	1 x 95
Rated current (A)	1000	Neutral conductor selected csa (mm ²)	1 x 95
Circuit breaker Q3		PE conductor selected csa (mm ²)	1 x 95
Load current (A)	518	Cable voltage drop ΔU (%)	0.131
Type	Compact	Total voltage drop ΔU (%)	0.714
Reference	NSX630F	3-phase short-circuit current I _{k3} (kA)	18.0
Rated current (A)	630	1-phase-to-earth fault current I _{ef} (kA)	14.2

Fig. G70 Partial results of calculation carried out with Ecodial software (Schneider Electric). The calculation is performed according to Cenelec TR50480 and IEC 60909

The same calculation using the simplified method recommended in this guide

■ Dimensioning circuit C1

The MV/LV 630 kVA transformer has a rated voltage of 400 V. Circuit C1 must be suitable for a current of:

$$I_b = \frac{630 \times 10^3}{\sqrt{3} \times 400} = 909 \text{ A per phase}$$

8 Worked example of cable calculation

Two single-core PVC-insulated copper cables in parallel will be used for each phase. These cables will be laid on cable trays according to method 31F.

Each conductor will therefore carry 455 A. Fig. G21 indicates that for 3 loaded conductors with PVC insulation, the required c.s.a. is 240 mm².

The resistance and the inductive reactance, for the two conductors in parallel, and for a length of 5 metres, are:

$$R = \frac{18.51 \times 5}{240 \times 2} = 0.19 \text{ m}\Omega \text{ (cable resistance: } 18.51 \text{ m}\Omega \cdot \text{mm}^2/\text{m at } 20 \text{ }^\circ\text{C)}$$

$$X = 0.08 / 2 \times 5 = 0.2 \text{ m}\Omega \text{ (cable reactance: } 0.08 \text{ m}\Omega/\text{m, 2 cables in parallel)}$$

■ Dimensioning circuit C3

Circuit C3 supplies two loads, in total 310 kW with $\cos \phi = 0.85$, so the total load current is:

$$I_b = \frac{310 \times 10^3}{\sqrt{3} \times 400 \times 0.85} = 526 \text{ A}$$

Two single-core PVC-insulated copper cables in parallel will be used for each phase. These cables will be laid on cable trays according to method F.

Each conductor will therefore carry 263 A. Fig. G21 indicates that for 3 loaded conductors with PVC insulation, the required c.s.a. is 120 mm².

The resistance and the inductive reactance, for the two conductors in parallel, and for a length of 20 metres, are:

$$R = \frac{18.51 \times 20}{120 \times 2} = 1.54 \text{ m}\Omega \text{ (cable resistance: } 18.51 \text{ m}\Omega \cdot \text{mm}^2/\text{m at } 20 \text{ }^\circ\text{C)}$$

$$X = 0.08 / 2 \times 20 = 0.8 \text{ m}\Omega \text{ (cable reactance: } 0.08 \text{ m}\Omega/\text{m, 2 cables in parallel)}$$

■ Dimensioning circuit C7

Circuit C7 supplies one 140kW load with $\cos \phi = 0.85$, so the total load current is:

$$I_b = \frac{140 \times 10^3}{\sqrt{3} \times 400 \times 0.85} = 238 \text{ A}$$

One single-core PVC-insulated copper cable will be used for each phase. The cables will be laid on cable trays according to method F.

Each conductor will therefore carry 238 A. Fig. G21 indicates that for 3 loaded conductors with PVC insulation, the required c.s.a. is 95 mm².

The resistance and the inductive reactance for a length of 5 metres is:

$$R = \frac{18.51 \times 5}{95} = 0.97 \text{ m}\Omega \text{ (cable resistance: } 18.51 \text{ m}\Omega \cdot \text{mm}^2/\text{m)}$$

$$X = 0.08 \times 5 = 0.4 \text{ m}\Omega \text{ (cable reactance: } 0.08 \text{ m}\Omega/\text{m)}$$

■ Calculation of short-circuit currents for the selection of circuit breakers Q1, Q3, Q7 (see Fig. G71)

Circuit components	R (mΩ)	X (mΩ)	Z (mΩ)	Ikmax (kA)
Upstream MV network, 500MVA fault level (see Fig. G36)	0.035	0.351		
Transformer 630kVA, 4 % (see Fig. G37)	2.90	10.8		
Cable C1	0.19	0.20		
Sub-total	3.13	11.4	11.8	21
Cable C3	1.54	0.80		
Sub-total	4.67	12.15	13.0	19
Cable C7	0.97	0.40		
Sub-total	5.64	12.55	13.8	18

Fig. G71 Example of short-circuit current evaluation

8 Worked example of cable calculation

■ **The protective conductor**

Generally, for circuits with phase conductor c.s.a. $S_{ph} \geq 50 \text{ mm}^2$, the PE conductor minimum c.s.a. will be $S_{ph} / 2$.

The proposed c.s.a. of the PE conductor will thus be $1 \times 240 \text{ mm}^2$ for circuit C1, $1 \times 120 \text{ mm}^2$ for C3, and $1 \times 50 \text{ mm}^2$ for C7.

The minimum c.s.a. for the protective earth conductor (PE) can be calculated using the adiabatic method (formula given in Fig. G59):

$$S_{PE} = \frac{\sqrt{I^2 \cdot t}}{k}$$

For circuit C1, $I = 21 \text{ kA}$ and $k = 143$.

t is the maximum operating time of the MV protection, e.g. 0.5 s

This gives:

$$S_{PE} = \frac{\sqrt{I^2 \cdot t}}{k} = \frac{21000 \times \sqrt{0.5}}{143} = 104 \text{ mm}^2$$

A single 120 mm^2 conductor is therefore largely sufficient, provided that it also satisfies the requirements for fault protection (indirect contact), i.e. that its impedance is sufficiently low.

■ **Fault protection (protection against indirect contact)**

For TN earthing system, the minimum value of L_{max} is given by phase to earth fault (highest impedance). Chapter F section "Implementation of TN system" details the calculation of typical phase-to-earth fault and maximum circuit length calculation.

In this example (3-phase 4-wire circuit), the maximum permitted length of the circuit is given by the formula:

$$L_{max} = \frac{0.8 \times U_0 \times S_{ph}}{\rho \times (1 + m) \times I_a}$$

where $m = S_{ph} / S_{PE}$

For circuit C3, this gives:

$$L_{max} = \frac{0.8 \times 230 \times 2 \times 120}{23.7 \times 10^{-3} \times (1+2) \times 630 \times 11} = 90 \text{ m}$$

(The value in the denominator 630×11 is the maximum current level at which the instantaneous short-circuit magnetic trip of the 630 A circuit breaker operates).

The length of 20 metres is therefore fully protected by "instantaneous" over-current devices.

■ **Voltage drop**

The voltage drop is calculated using the data given in Fig. G30, for balanced three-phase circuits, motor power normal service ($\cos \varphi = 0.8$).

The results are summarized on Fig. G72:

The total voltage drop at the end of cable C7 is then: 0.73% .

	C1	C3	C7
c.s.a.	2 x 240 mm ²	2 x 120 mm ²	1 x 95 mm ²
ΔU per conductor (V/A/km) see Fig. G30	0.22	0.36	0.43
Load current (A)	909	526	238
Length (m)	5	20	5
Voltage drop (V)	0.50	1.89	0.51
Voltage drop (%)	0.12	0.47	0.13

Fig. G72 Voltage drop introduced by the different cables

G - Sizing and protection of conductors

G48

LV switchgear: functions & selection

1	The basic functions of LV switchgear	H2
	1.1 Electrical protection	H2
	1.2 Isolation	H3
	1.3 Switchgear control	H4
2	The switchgear	H5
	2.1 Elementary switching devices	H5
	2.2 Combined switchgear elements	H9
3	Choice of switchgear	H10
	3.1 Switchgear selection	H10
	3.2 Tabulated functional capabilities of LV switchgear	H10
4	Circuit breaker	H11
	4.1 Standards and description	H11
	4.2 Fundamental characteristics of a circuit breaker	H13
	4.3 Other characteristics of a circuit breaker	H15
	4.4 Selection of a circuit breaker	H18
	4.5 Coordination between circuit breakers	H23
	4.6 Selectivity MV/LV in a consumer's substation	H27
	4.7 Ultra rapid circuit breaker	H28
5	Maintenance of low voltage switchgear	H31

1 The basic functions of LV switchgear

The role of switchgear is:

- Electrical protection
- Safe isolation from live parts
- Local or remote switching

switchgear

General term covering switching devices and their combination with associated control, measuring, protective and regulating equipment, also assemblies of such devices and equipment with associated interconnections, accessories, enclosures and supporting structures, intended in principle for use in connection with generation, transmission, distribution and conversion of electric energy [IEV 441-11-02].

Low voltage electrical installation rules such as IEC 60364 series and related national standards give:

- rules for design and erection of electrical installation, and
 - requirement for selection of electrical equipment including the devices to ensure protection and control of the electrical installation.
- These devices are collectively referred to as «switchgear».

The main functions of switchgear are:

- Electrical protection
- Electrical isolation of the electrical installation, circuits or individual equipment
- Local or remote switching

These functions are summarized below in Fig. H1.

In addition to those functions shown in Fig. H1, other functions, namely:

- Over-voltage protection
- Under-voltage protection

are provided by specific devices (lightning and various other types of voltage-surge arrester, relays associated with contactors, remotely controlled circuit breakers, and with combined circuit breaker/isolators... and so on)

Electrical protection against	Isolation	Control
<ul style="list-style-type: none"> ■ Overload currents ■ Short-circuit currents ■ Insulation failure 	<ul style="list-style-type: none"> ■ Isolation clearly indicated by an authorized fail-proof mechanical indicator ■ A gap or interposed insulating barrier between the open contacts, clearly visible 	<ul style="list-style-type: none"> ■ Functional switching ■ Emergency switching ■ Emergency stopping ■ Switching off for mechanical maintenance

Fig. H1 Basic functions of LV switchgear

Electrical protection assures:

- Protection of circuit elements against the thermal and mechanical stresses of short-circuit currents
- Protection of persons in the event of insulation failure
- Protection of appliances and apparatus being supplied (e.g. motors, etc.)

1.1 Electrical protection

The aim is to avoid or to limit the destructive or dangerous consequences of excessive (short-circuit) currents, or those due to overloading and insulation failure, and to separate the defective circuit from the rest of the installation.

A distinction is made between the protection of:

- The elements of the installation or circuits (cables, wires, switchgear...)
- Persons and animals
- Equipment and appliances supplied from the installation

The protection of circuits:

- Against overload; a condition of excessive current being drawn from a healthy (unfaulted) installation
- Against short-circuit currents due to complete failure of insulation between conductors of different phases or between a phase and neutral conductor or between a phase and PE or earth.

Protection in these cases is provided by overcurrent protective devices.

Such devices could be circuit-breaker (IEC 60898, IEC 60947-2, IEC 60947-6-2, IEC 61009), or fuses (IEC 60269-2, IEC 60269-3, IEC 60269-4 or IEC 60947-3).

The protection of persons

According to IEC 60364-4-41, Automatic disconnection in case of fault is a protective measure permitted for protection against electric shock.

Circuit breaker or fuses can be used as protective devices that «automatically interrupt the supply to the line conductor of a circuit or equipment in the event of a fault of negligible impedance between the line conductor and an exposed-conductive-part or a protective conductor in the circuit or equipment within the disconnection time required « (IEC 60364-4-41 sub-clause 411).

1 The basic functions of LV switchgear

The protection of appliances (e.g electric motors)

Switchgear such as circuit breakers or fuses can also provide protection of appliance alone or with additional relay. For induction motor for example protection against long start , stalled rotor, single-phasing could be required. Against overheating, due, for example, to long term overloading, stalled rotor, single-phasing, etc. Overload relays specially designed to match the particular characteristics of motors are used.

Such relays may, if required, also protect the motor-circuit cable against overload.

1.2 Isolation

A state of isolation clearly indicated by an approved “fail-proof” indicator, or the visible separation of contacts, are both deemed to satisfy the national standards of many countries

The aim of isolation is to separate a circuit or apparatus (such as a motor, etc.) from the remainder of a system which is energized, in order that personnel may carry out work on the isolated part in perfect safety.

In principle, all circuits of an LV installation shall have means to be isolated. In practice, in order to maintain an optimum continuity of service, it is preferred to provide a means of isolation at the origin of each circuit.

An isolating device must fulfil the following requirements:

- All poles of a circuit, including the neutral (except where the neutral is a PEN conductor) must open^[1]
- It must be provided with a locking system in open position with a key (e.g. by means of a padlock) in order to avoid an unauthorized reclosure by inadvertence
- It must comply with a recognized national or international standard (e.g. IEC 60947-3) concerning clearance between contacts, creepage distances, overvoltage withstand capability, etc.:

Other requirements apply:

- Verification that the contacts of the isolating device are, in fact, open.
The verification may be:
 - Either visual, where the device is suitably designed to allow the contacts to be seen (some national standards impose this condition for an isolating device located at the origin of a LV installation supplied directly from a MV/LV transformer)
 - Or mechanical, by means of an indicator solidly welded to the operating shaft of the device. In this case the construction of the device must be such that, in the eventuality that the contacts become welded together in the closed position, the indicator cannot possibly indicate that it is in the open position
- Leakage currents. With the isolating device open, leakage currents between the open contacts of each phase must not exceed:
 - 0.5 mA for a new device
 - 6.0 mA at the end of its useful life
- Voltage-surge withstand capability, across open contacts. The isolating device, when open must withstand a 1.2/50 µs impulse, having a peak value of 6, 8 or 12 kV according to its service voltage, as shown in Fig. H2. The device must satisfy these conditions for altitudes up to 2,000 metres. Correction factors are given in IEC 60664-1 for altitudes greater than 2,000 metres.

System voltage	Impulse-withstand voltage for isolating devices kV	
	Overvoltage category III	Overvoltage category IV
400/230V 480/277V	4	6
690/400V	6	8
1000/577V	8	12

Fig. H2 Peak value of impulse voltage according to normal service voltage. Overvoltage category III and IV are defined in IEC 60664-1

- Equipment of overvoltage category IV is for use at the origin of the installation.
- Equipment of overvoltage category III is for all other equipments in fixed installations

[1] the concurrent opening of all live conductors, while not always obligatory, is however, strongly recommended (for reasons of greater safety and facility of operation). A switched neutral pole shall break not before and shall make not after the other poles (IEC 60947-1).

1 The basic functions of LV switchgear

Switchgear-control functions allow system operating personnel to modify a loaded system at any moment, according to requirements, and include:

- Functional control (routine switching, etc.)
- Emergency switching
- Maintenance operations on the power system

1.3 Switchgear control

In broad terms “control” signifies any facility for safely modifying a load-carrying power system at all levels of an installation. The operation of switchgear is an important part of power-system control.

Functional control

This control relates to all switching operations in normal service conditions for energizing or de-energizing a part of a system or installation, or an individual piece of equipment, item of plant, etc.

Switchgear intended for such duty must be installed at least:

- At the origin of any installation
- At the final load circuit or circuits (one switch may control several loads)

Marking (of the circuits being controlled) must be clear and unambiguous.

In order to provide the maximum flexibility and continuity of operation, particularly where the switching device also constitutes the protection (e.g. a circuit breaker or switch-fuse) it is preferable to include a switch at each level of distribution, i.e. on each outgoing way of all distribution and subdistribution boards.

The operation may be:

- Either manual (by means of an operating lever on the switch) or
- Electric, by push-button on the switch or at a remote location (load-shedding and reconnection, for example)

These switches operate instantaneously (i.e. with no deliberate delay), and those that provide protection are invariably omni-polar^[1].

The main circuit breaker for the entire installation, as well as any circuit breakers used for change-over (from one source to another) must be omni-polar units.

Emergency switching - emergency stop

An emergency switching is intended to de-energize a live circuit which is, or could become, dangerous (electric shock or fire).

An emergency stop is intended to halt a movement which has become dangerous.

In the two cases:

- The emergency control device or its means of operation (local or at remote location(s)) such as a large red mushroom-headed emergency-stop pushbutton must be recognizable and readily accessible, in proximity to any position at which danger could arise or be seen
- A single action must result in a complete switching-off of all live conductors^{[2] [3]}
- A “break glass” emergency switching initiation device is authorized, but in unmanned installations the re-energizing of the circuit can only be achieved by means of a key held by an authorized person

It should be noted that in certain cases, an emergency system of braking, may require that the auxiliary supply to the braking-system circuits be maintained until final stoppage of the machinery.

Switching-off for mechanical maintenance work

This operation assures the stopping of a machine and its impossibility to be inadvertently restarted while mechanical maintenance work is being carried out on the driven machinery. The shutdown is generally carried out at the functional switching device, with the use of a suitable safety lock and warning notice at the switch mechanism.

[1] One break in each phase and (where appropriate) one break in the neutral.

[2] Taking into account stalled motors.

[3] In a TN schema the PEN conductor must never be opened, since it functions as a protective earthing wire as well as the system neutral conductor.

2 The switchgear

DB42230 eps



Fig. H3 Symbol for a disconnector (or isolator)

DB42231 eps

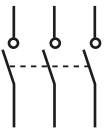


Fig. H4 Symbol for a load-break switch

2.1 Elementary switching devices

Disconnecter (or isolator) (see Fig. H3)

This switch is a manually-operated, lockable, two-position device (open/closed) which provides safe isolation of a circuit when locked in the open position. Its characteristics are defined in IEC 60947-3. A disconnector is not designed to make or to break current [1] and no rated values for these functions are given in standards. It must, however, be capable of withstanding the passage of short-circuit currents and is assigned a rated short-time withstand capability, generally for 1 second, unless otherwise agreed between user and manufacturer. This capability is normally more than adequate for longer periods of (lower-valued) operational overcurrents, such as those of motor-starting. Standardized mechanical-endurance, overvoltage, and leakage-current tests, must also be satisfied.

Load-breaking switch (see Fig. H4)

This control switch is generally operated manually (but is sometimes provided with electrical tripping for operator convenience) and is a non-automatic two-position device (open/closed).

It is used to close and open loaded circuits under normal unfaulted circuit conditions.

It does not consequently, provide any protection for the circuit it controls.

IEC standard 60947-3 defines:

- The frequency of switch operation (600 close/open cycles per hour maximum)
 - Mechanical and electrical endurance (generally less than that of a contactor)
 - Current making and breaking ratings for normal and infrequent situations
- When closing a switch to energize a circuit there is always the possibility that an unsuspected short-circuit exists on the circuit. For this reason, load-break switches are assigned a fault-current making rating, i.e. successful closure against the electrodynamic forces of short-circuit current is assured. Such switches are commonly referred to as “fault-make load-break” switches. Upstream protective devices are relied upon to clear the short-circuit fault

Category AC-23 includes occasional switching of individual motors. The switching of capacitors or of tungsten filament lamps shall be subject to agreement between manufacturer and user.

The utilization categories referred to in Fig. H5 do not apply to an equipment normally used to start, accelerate and/or stop individual motors.

Example

A 100 A load-break switch of category AC-23 (inductive load) must be able:

- To make a current of 10 I_n (= 1,000 A) at a power factor of 0.35 lagging
- To break a current of 8 I_n (= 800 A) at a power factor of 0.45 lagging
- To withstand short duration short-circuit currents when closed

H5

Utilization category		Typical applications	Cos φ	Making current x I _n	Breaking current x I _n
Frequent operations	Infrequent operations				
AC-20A	AC-20B	Connecting and disconnecting under no-load conditions	-	-	-
AC-21A	AC-21B	Switching of resistive loads including moderate overloads	0.95	1.5	1.5
AC-22A	AC22B	Switching of mixed resistive and inductive loads, including moderate overloads	0.65	3	3
AC-23A	AC-23B	Switching of motor loads or other highly inductive loads	0.45 for I ≤ 100 A 0.35 for I > 100 A	10	8

Fig. H5 Utilization categories of LV AC switches according to IEC 60947-3

[1] i.e. a LV disconnector is essentially a dead system switching device to be operated with no voltage on either side of it, particularly when closing, because of the possibility of an unsuspected short-circuit on the downstream side. Interlocking with an upstream switch or circuit breaker is frequently used.

2 The switchgear

DB422392_EN.eps

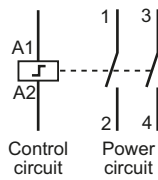


Fig. H6 Symbol for a bistable remote control switch (impulse relay)

DB422393_EN.eps

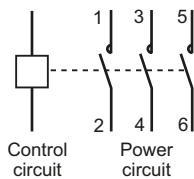


Fig. H7 Symbol for a monostable remote control switch (contactor, relay)

H6

Impulse relay (see Fig. H6)

This device is extensively used in the control of lighting circuits where the depression of a pushbutton (at a remote control position) will open an already-closed switch or close an opened switch in a bistable sequence.

Typical applications are:

- Two way or more switching points in stairways, corridors in housing or commercial building
- Large space (open space) in office building
- Industrial facilities.

Auxiliary devices are available to provide:

- Remote indication of its state at any instant
- Time-delay functions
- Maintained-contact features

Contactor (see Fig. H7)

The contactor is a solenoid-operated switching device which is generally held closed by (a reduced) current through the closing solenoid (although various mechanically-latched types exist for specific duties). Contactors are designed to carry out numerous close/open cycles and are commonly controlled remotely by on-off pushbuttons. The large number of repetitive operating cycles is standardized in table VIII of IEC 60947-4-1 by:

- The operating duration: 8 hours; uninterrupted; intermittent; temporary of 3, 10, 30, 60 and 90 minutes
- Utilization category: for example, a contactor of category AC3 can be used for the starting and stopping of a cage motor
- The start-stop cycles (1 to 1,200 cycles per hour)
- Mechanical endurance (number of off-load manoeuvres)
- Electrical endurance (number of on-load manoeuvres)
- A rated current making and breaking performance according to the category of utilization concerned

Example:

A 150 A contactor of category AC3 must have a minimum current-breaking capability of $8 I_n (= 1,200 \text{ A})$ and a minimum current-making rating of $10 I_n (= 1,500 \text{ A})$ at a power factor (lagging) of 0.35.

Discontactor ^[1]

A contactor equipped with a thermal-type relay for protection against overloading defines a "discontactor". Discontactors are used and considered as an essential element in a motor controller, as noted in sub-clause 2.2. "combined switchgear elements". The discontactor is not the equivalent of a circuit breaker, since its short-circuit current breaking capability is limited to 8 or 10 I_n . For short-circuit protection therefore, it is necessary to include either fuses or a circuit breaker in series with, and upstream of, the discontactor contacts.

Integrated control circuit breaker

"Integrated control circuit breaker" is a single device which combines the following main and additional functions :

- Circuit breaker for cables protection
- Remote control by latched or/and impulse type orders
- Remote indication of status
- Interface compatible with building management system

That type of device allows simplifying design and implementation in switchboard.

Fuses (see Fig. H8)

The first letter indicates the breaking range:

- "g" fuse-links (full-range breaking-capacity fuse-link)
- "a" fuse-links (partial-range breaking-capacity fuse-link)

The second letter indicates the utilization category; this letter defines with accuracy the time-current characteristics, conventional times and currents, gates.

For example

- "gG" indicates fuse-links with a full-range breaking capacity for general application
- "gM" indicates fuse-links with a full-range breaking capacity for the protection of motor circuits
- "aM" indicates fuse-links with a partial range breaking capacity for the protection of motor circuits

Two classes of LV cartridge fuse are very widely used:

- For domestic and similar installations type gG
- For industrial installations type gG, gM or aM

[1] This term is not defined in IEC publications but is commonly used in some countries.

2 The switchgear

DB422394.eps

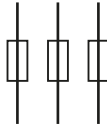


Fig. H8 Symbol for fuses

Fuses exist with and without “fuse-blown” mechanical indicators. Fuses break a circuit by controlled melting of the fuse element when a current exceeds a given value for a corresponding period of time; the current/time relationship being presented in the form of a performance curve for each type of fuse. Standards define two classes of fuse:

- Those intended for domestic installations, manufactured in the form of a cartridge for rated currents up to 100 A and designated type gG in IEC 60269-1 and 3
- Those for industrial use, with cartridge types designated gG (general use); and gM and aM (for motor-circuits) in IEC 60269-1 and 2

The main differences between domestic and industrial fuses are the nominal voltage and current levels (which require much larger physical dimensions) and their fault-current breaking capabilities. Type gG fuse-links are often used for the protection of motor circuits, which is possible when their characteristics are capable of withstanding the motor-starting current without deterioration.

A more recent development has been the adoption by the IEC of a fuse-type gM for motor protection, designed to cover starting, and short-circuit conditions. This type of fuse is more popular in some countries than in others, but at the present time the aM fuse in combination with a thermal overload relay is more-widely used.

A gM fuse-link, which has a dual rating is characterized by two current values. The first value I_n denotes both the rated current of the fuse-link and the rated current of the fuseholder; the second value I_{ch} denotes the time-current characteristic of the fuse-link as defined by the gates in Tables II, III and VI of IEC 60269-1.

These two ratings are separated by a letter which defines the applications.

For example: $I_n M I_{ch}$ denotes a fuse intended to be used for protection of motor circuits and having the characteristic G. The first value I_n corresponds to the maximum continuous current for the whole fuse and the second value I_{ch} corresponds to the G characteristic of the fuse link. For further details see note at the end of sub-clause 2.1.

An aM fuse-link is characterized by one current value I_n and time-current characteristic as shown in Fig. H11 next page.

Important: Some national standards use a gl (industrial) type fuse, similar in all main essentials to type gG fuses.

Type gl fuses should never be used, however, in domestic and similar installations.

H7

gM fuses require a separate overload relay, as described in the note at the end of this sub-clause 2.1.

DB422395_EN.eps

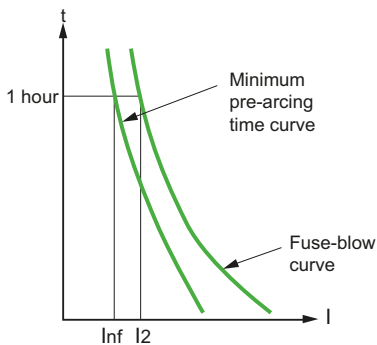


Fig. H9 Zones of fusing and non-fusing for gG and gM fuses

Fusing zones - conventional currents

The conditions of fusing (melting) of a fuse are defined by standards, according to their class.

Class gG fuses

These fuses provide protection against overloads and short-circuits.

Conventional non-fusing and fusing currents are standardized, as shown in Fig. H9 and in Fig. H10.

- The conventional non-fusing current I_{nf} is the value of current that the fusible element can carry for a specified time without melting.

Example: A 32 A fuse carrying a current of $1.25 I_n$ (i.e. 40 A) must not melt in less than one hour (Fig. H10)

- The conventional fusing current I_f ($= I_2$ in Fig. H9) is the value of current which will cause melting of the fusible element before the expiration of the specified time.
- Example: A 32 A fuse carrying a current of $1.6 I_n$ (i.e. 52.1 A) must melt in one hour or less

IEC 60269-1 standardized tests require that a fuse-operating characteristic lies between the two limiting curves (shown in Fig. H9) for the particular fuse under test. This means that two fuses which satisfy the test can have significantly different operating times at low levels of overloading.

Rated current I_n (A)	Conventional non-fusing current I_{nf}	Conventional fusing current I_2	Conventional time (h)
$I_n \leq 4$ A	$1.5 I_n$	$2.1 I_n$	1
$4 < I_n < 16$ A	$1.5 I_n$	$1.9 I_n$	1
$16 < I_n \leq 63$ A	$1.25 I_n$	$1.6 I_n$	1
$63 < I_n \leq 160$ A	$1.25 I_n$	$1.6 I_n$	2
$160 < I_n \leq 400$ A	$1.25 I_n$	$1.6 I_n$	3
$400 < I_n$	$1.25 I_n$	$1.6 I_n$	4

[a] I_{ch} for gM fuses.

Fig. H10 Zones of fusing and non-fusing for LV types gG and gM class fuses (IEC 60269-1 and 60269-2-1)

2 The switchgear

Class aM fuses protect against short-circuit currents only, and must always be associated with another device which protects against overload

■ The two examples given above for a 32 A fuse, together with the foregoing notes on standard test requirements, explain why these fuses have a poor performance in the low overload range

■ It is therefore necessary to install a cable larger in ampacity than that normally required for a circuit, in order to avoid the consequences of possible long term overloading (60% overload for up to one hour in the worst case)

By way of comparison, a circuit breaker of similar current rating:

- Which passes 1.05 I_n must not trip in less than one hour; and
- When passing 1.25 I_n it must trip in one hour, or less (25% overload for up to one hour in the worst case)

Class aM (motor) fuses

These fuses afford protection against short-circuit currents only and must necessarily be associated with other switchgear (such as discontactors or circuit breakers) in order to ensure overload protection < 4 I_n . They are not therefore autonomous. Since aM fuses are not intended to protect against low values of overload current, no levels of conventional non-fusing and fusing currents are fixed.

The characteristic curves for testing these fuses are given for values of fault current exceeding approximately 4 I_n (see Fig. H11), and fuses tested to IEC 60269 must give operating curves which fall within the shaded area.

Note: the small "arrowheads" in the diagram indicate the current/time "gate" values for the different fuses to be tested (IEC 60269).

Rated short-circuit breaking currents

A characteristic of modern cartridge fuses is that, owing to the rapidity of fusion in the case of high short-circuit current levels^[1], a current cut-off begins before the occurrence of the first major peak, so that the fault current never reaches its prospective peak value (see Fig. H12).

This limitation of current reduces significantly the thermal and dynamic stresses which would otherwise occur, thereby minimizing danger and damage at the fault position. The rated short-circuit breaking current of the fuse is therefore based on the rms value of the AC component of the prospective fault current.

No short-circuit current-making rating is assigned to fuses.

Reminder

Short-circuit currents initially contain DC components, the magnitude and duration of which depend on the XL/R ratio of the fault current loop.

Close to the source (MV/LV transformer) the relationship I_{peak} / I_{rms} (of AC component) immediately following the instant of fault, can be as high as 2.5 (standardized by IEC, and shown in Fig. H13 next page).

At lower levels of distribution in an installation, as previously noted, XL is small compared with R and so for final circuits $I_{peak} / I_{rms} \sim 1.41$, a condition which corresponds with Fig. H12.

The peak-current-limitation effect occurs only when the prospective rms AC component of fault current attains a certain level. For example, in the Fig. H13 graph, the 100 A fuse will begin to cut off the peak at a prospective fault current (rms) of 2 kA (a). The same fuse for a condition of 20 kA rms prospective current will limit the peak current to 10 kA (b). Without a current-limiting fuse the peak current could attain 50 kA (c) in this particular case. As already mentioned, at lower distribution levels in an installation, R greatly predominates XL, and fault levels are generally low. This means that the level of fault current may not attain values high enough to cause peak current limitation. On the other hand, the DC transients (in this case) have an insignificant effect on the magnitude of the current peak, as previously mentioned.

Note: On gM fuse ratings

A gM type fuse is essentially a gG fuse, the fusible element of which corresponds to the current value I_{ch} (ch = characteristic) which may be, for example, 63 A. This is the IEC testing value, so that its time/ current characteristic is identical to that of a 63 A gG fuse.

This value (63 A) is selected to withstand the high starting currents of a motor, the steady state operating current (I_n) of which may be in the 10-20 A range.

This means that a physically smaller fuse barrel and metallic parts can be used, since the heat dissipation required in normal service is related to the lower figures (10-20 A). A standard gM fuse, suitable for this situation would be designated 32M63 (i.e. I_n M I_{ch}).

The first current rating I_n concerns the steady-load thermal performance of the fuselink, while the second current rating (I_{ch}) relates to its (short-time) starting-current performance. It is evident that, although suitable for short-circuit protection, overload protection for the motor is not provided by the fuse, and so a separate

DB422396_EN.eps

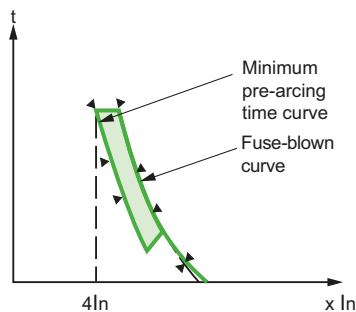
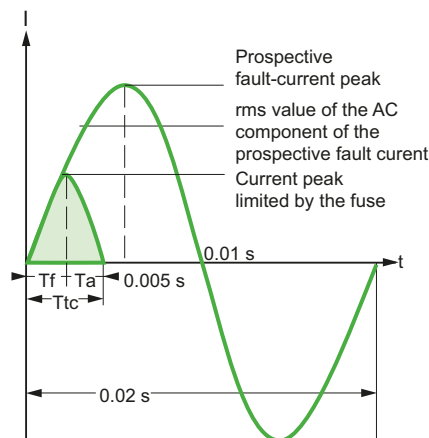


Fig. H11 Standardized zones of fusing for type aM fuses (all current ratings)

DB422397_EN.eps



Tf: Fuse pre-arc fusing time
Ta: Arcing time
Ttc: Total fault-clearance time

Fig. H12 Current limitation by a fuse

[1] For currents exceeding a certain level, depending on the fuse nominal current rating, as shown below in Figure H16.

2 The switchgear

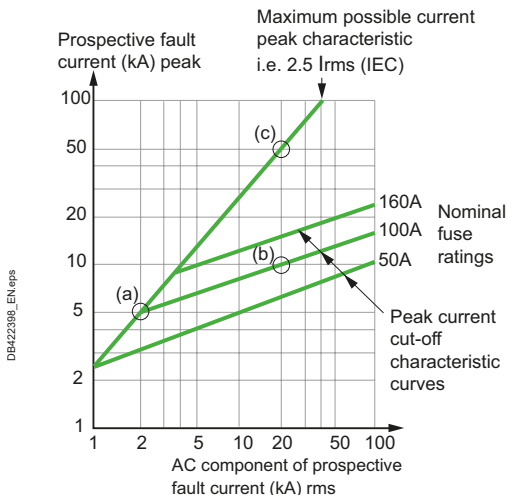


Fig. H13 Limited peak current versus prospective rms values of the AC component of fault current for LV fuses

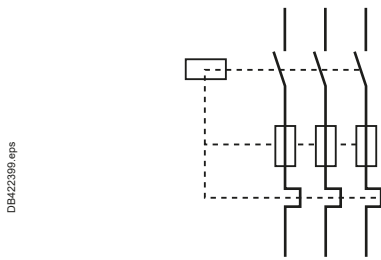


Fig. H14 Symbol for an automatic tripping switch-fuse

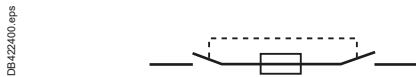


Fig. H15 Symbol for a non-automatic fuse-switch

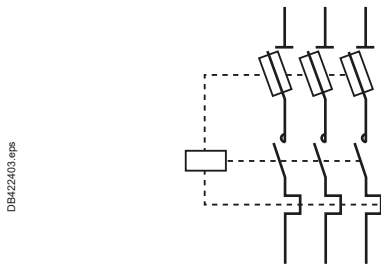


Fig. H17 Symbol for a fuse disconnecter + disconnector

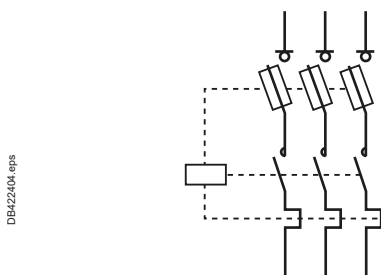


Fig. H18 Symbol for a fuse-switch disconnecter + disconnector

thermal-type relay is always necessary when using gM fuses. The only advantage offered by gM fuses, therefore, when compared with aM fuses, are reduced physical dimensions and slightly lower cost.

2.2 Combined switchgear elements

Single units of switchgear do not, in general, fulfil all the requirements of the three basic functions, viz: Protection, control and isolation.

Where the installation of a circuit breaker is not appropriate (notably where the switching rate is high, over extended periods) combinations of units specifically designed for such a performance are employed. The most commonly-used combinations are described below.

Switch and fuse combinations

Two cases are distinguished:

- The type in which the operation of one (or more) fuse(s) causes the switch to open. This is achieved by the use of fuses fitted with striker pins, and a system of switch tripping springs and toggle mechanisms (see Fig. H14)
- The type in which a non-automatic switch is associated with a set of fuses in a common enclosure.

In some countries, and in IEC 60947-3, the terms “switch-fuse” and “fuse-switch” have specific meanings, viz:

- A switch-fuse comprises a switch (generally 2 breaks per pole) on the upstream side of three fixed fuse-bases, into which the fuse carriers are inserted (see Fig. H15)
- A fuse-switch consists of three switch blades each constituting a double-break per phase.

These blades are not continuous throughout their length, but each has a gap in the centre which is bridged by the fuse cartridge. Some designs have only a single break per phase, as shown in Fig. H16.

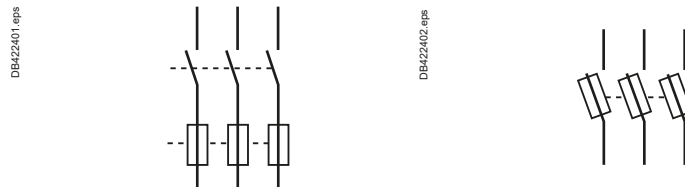


Fig. H16 Symbol for a non-automatic switch-fuse

The current range for these devices is limited to 100 A maximum at 400 V 3-phase, while their principal use is in domestic and similar installations. To avoid confusion between the first group (i.e. automatic tripping) and the second group, the term “switch-fuse” should be qualified by the adjectives “automatic” or “non-automatic”.

Fuse – disconnecter + disconnector

Fuse - switch-disconnector + disconnector

As previously mentioned, a disconnector does not provide protection against short-circuit faults. It is necessary, therefore, to add fuses (generally of type aM) to perform this function. The combination is used mainly for motor control circuits, where the disconnector or switch-disconnector allows safe operations such as:

- The changing of fuse links (with the circuit isolated)
- Work on the circuit downstream of the disconnector (risk of remote closure of the disconnector)

The fuse-disconnector must be interlocked with the disconnector such that no opening or closing manoeuvre of the fuse disconnecter is possible unless the disconnector is open (Fig. H17), since the fuse disconnecter has no load-switching capability.

A fuse-switch-disconnector (evidently) requires no interlocking (Fig. H18). The switch must be of class AC22 or AC23 if the circuit supplies a motor.

Circuit breaker + contactor

Circuit breaker + disconnector

These combinations are used in remotely controlled distribution systems in which the rate of switching is high, or for control and protection of a circuit supplying motors.

3 Choice of switchgear

3.1 Switchgear selection

Software is being used more and more in the field of optimal selection of switchgear. Each circuit is considered one at a time, and a list is drawn up of the required protection functions and exploitation of the installation, among those mentioned in Fig. H19 and summarized in Fig. H1.

A number of switchgear combinations are studied and compared with each other against relevant criteria, with the aim of achieving:

- Satisfactory performance
- Compatibility among the individual items; from the rated current I_n to the fault-level rating I_{cu}
- Compatibility with upstream switchgear or taking into account its contribution
- Conformity with all regulations and specifications concerning safe and reliable circuit performance

In order to determine the number of poles for an item of switchgear, reference is made to chapter G, clause 7 Fig. G68. Multifunction switchgear, initially more costly, reduces installation costs and problems of installation or exploitation. It is often found that such switchgear provides the best solution.

3.2 Tabulated functional capabilities of LV switchgear

After having studied the basic functions of LV switchgear (clause 1, Fig. H1) and the different components of switchgear (clause 2), Fig. H19 summarizes the capabilities of the various components to perform the basic functions.

H10

Switchgear item	Isolation	Control				Electrical protection		
		Functional	Emergency switching	Emergency stop (mechanical)	Switching for mechanical maintenance	Overload	Short-circuit	Electric shock
Isolator (or disconnector) ^[d]	■							
Switch ^[e]	■	■	■ [a]	■ [a] [b]	■			
Residual device (RCCB) ^[e]	■	■	■ [a]	■ [a] [b]	■			■
Switch-disconnector	■	■	■ [a]	■ [a] [b]	■			
Contactors		■	■ [a]	■ [a] [b]	■	■ [c]		
Remote control switch		■	■ [a]	■ [a] [b]	■			
Fuse	■	■	■ [a]	■ [a] [b]	■	■	■	[f]
Circuit breaker	■	■	■ [a]	■ [a] [b]	■	■	■	[f]
Circuit breaker disconnector ^[e]	■	■	■ [a]	■ [a] [b]	■	■	■	[f]
Residual and overcurrent circuit breaker (RCBO) ^[e]	■	■	■ [a]	■ [a] [b]	■	■	■	■
Point of installation (general principle)	Origin of each circuit	All points where, for operational reasons it may be necessary to stop the process	In general at the incoming circuit to every distribution board	At the supply point to each machine and/or on the machine concerned	At the supply point to each machine	Origin of each circuit	Origin of each circuit	Origin of circuits where the earthing system is appropriate TN-S, IT, TT

[a] Where cut-off of all active conductors is provided

[b] It may be necessary to maintain supply to a braking system

[c] If it is associated with a thermal relay (the combination is commonly referred to as a “discontactor”)

[d] In certain countries a disconnector with visible contacts is mandatory at the origin of a LV installation supplied directly from a MV/LV transformer

[e] Certain items of switchgear are suitable for isolation duties (e.g. RCCBs according to IEC 61008) without being explicitly marked as such

[f] Circuit breaker and fuse can ensure also protective measure in case of fault by automatic disconnection of the supply

Fig. H19 Functions fulfilled by different items of switchgear

4 Circuit breaker

The circuit breaker/disconnector fulfills all of the basic switchgear functions, while, by means of accessories, numerous other possibilities exist

As shown in **Fig. H20** the circuit breaker/ disconnector is the only item of switchgear capable of simultaneously satisfying all the basic functions necessary in an electrical installation.

Moreover, it can, by means of auxiliary units, provide a wide range of other functions, for example: indication (on-off - tripped on fault); undervoltage tripping; remote control etc. These features make a circuit breaker/ disconnector the basic unit of switchgear for any electrical installation.

Functions		Possible conditions
Isolation		■
Control	Functional	■
	Emergency switching	□ (With the possibility of a tripping coil for remote control)
	Switching-off for mechanical maintenance	■
Protection	Overload	■
	Short-circuit	■
	Insulation fault	□ (With differential-current relay)
	Undervoltage	□ (With undervoltage-trip coil)
Remote control		□ Added or incorporated
Indication and measurement		□ (Generally optional with an electronic tripping device)

Fig. H20 Functions performed by a circuit breaker/disconnector

Industrial circuit breakers must comply with IEC 60947-1 and 60947-2 or other equivalent standards
 Domestic-type circuit breakers must comply with IEC standard 60898, or an equivalent national standard

4.1 Standards and description

Standards

For industrial LV installations the relevant IEC standards are, or are due to be:

- 60947-1: general rules
- 60947-2: part 2: circuit breakers
- 60947-3: part 3: switches, disconnectors, switch-disconnectors and fuse combination units
- 60947-4: part 4: contactors and motor starters
- 60947-5: part 5: control-circuit devices and switching elements
- 60947-6: part 6: multiple function switching devices
- 60947-7: part 7: ancillary equipment
- 60947-8: Part 8: Control units for built-in thermal protection (PTC) for rotating electrical machines.

For domestic and similar LV installations, the appropriate standard is IEC 60898, or an equivalent national standard.

Description

Fig. H21 shows schematically the main parts of a LV circuit breaker and its four essential functions:

- The circuit-breaking components, comprising the fixed and moving contacts and the arc-dividing chamber
- The latching mechanism which becomes unlatched by the tripping device on detection of abnormal current conditions

This mechanism is also linked to the operation handle of the breaker.

- A trip-mechanism actuating device:
 - Either: a thermal-magnetic device, in which a thermally-operated bi-metal strip detects an overload condition, while an electromagnetic striker pin operates at current levels reached in short-circuit conditions, or
 - An electronic relay operated from current transformers, one of which is installed on each phase
- A space allocated to the several types of terminal currently used for the main power circuit conductors

Domestic circuit breakers (see **Fig. H22** next page) complying with IEC 60898 and similar national standards perform the basic functions of:

- Isolation
- Protection against overcurrent

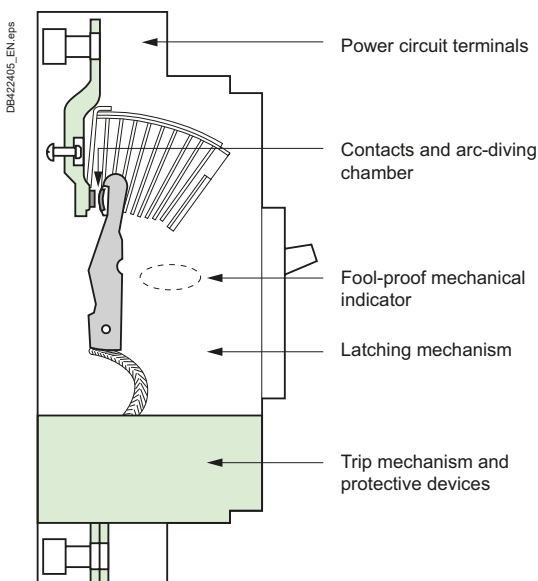


Fig. H21 Main parts of a circuit breaker

4 Circuit breaker

PB116761.eps



Fig. H22 Domestic-type circuit breaker providing overcurrent protection and circuit isolation features

PB116762.eps



Fig. H23 Domestic-type circuit breaker with incorporated protection against electric shocks

Some models can be adapted to provide sensitive detection (30 mA) of earth-leakage current with CB tripping, by the addition of a modular block, while other models (RCBOs, complying with IEC 61009 and CBRs complying with IEC 60947-2 Annex B) have this residual current feature incorporated as shown in **Fig. H23**.

Apart from the above-mentioned functions further features can be associated with the basic circuit breaker by means of additional modules, as shown in **Fig. H24**; notably remote control and indication (on-off-fault).

DB422406_EN.eps

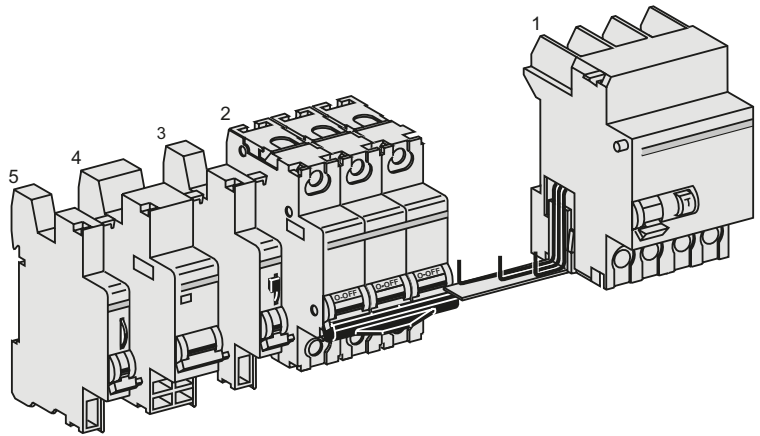


Fig. H24 "Acti 9" system of LV modular switchgear components

Moulded-case circuit breakers complying with IEC 60947-2 are available from 100 to 630 A and provide a similar range of auxiliary functions to those described above (see **Fig. H25**).

Air circuit breakers of large current ratings, complying with IEC 60947-2, are generally used in the main switch board and provide protector for currents from 630 A to 6300 A, typically.(see **Fig. H26**).

In addition to the protection functions, the Micrologic unit provides optimized functions such as measurement (including power quality functions), diagnosis, communication, control and monitoring.

PB105112_z.eps



Fig. H25 Example of a Compact NSX industrial type of circuit breaker capable of numerous auxiliary functions

PB116184-50.eps



PB116047_20.eps



Fig. H26 Example of air circuit breakers. Masterpact provides many control features in its "Micrologic" tripping unit

4 Circuit breaker

4.2 Fundamental characteristics of a circuit breaker

The fundamental characteristics of a circuit breaker are:

- Its rated voltage U_e
- Its rated current I_n
- Its tripping-current-level adjustment ranges for overload protection ($I_r^{[1]}$ or $I_{rth}^{[1]}$) and for short-circuit protection (I_m)^[1]
- Its short-circuit current breaking rating (I_{cu} for industrial CBs; I_{cn} for domestic-type CBs).

Rated operational voltage (U_e)

This is the voltage at which the circuit breaker has been designed to operate, in normal (undisturbed) conditions.

Other values of voltage are also assigned to the circuit breaker, corresponding to disturbed conditions, as noted in sub-clause 4.3.

Rated current (I_n)

This is the maximum value of current that a circuit breaker, fitted with a specified overcurrent tripping relay, can carry indefinitely at an ambient temperature stated by the manufacturer, without exceeding the specified temperature limits of the current carrying parts.

Example

A circuit breaker rated at $I_n = 125$ A for an ambient temperature of 40 °C will be equipped with a suitably calibrated overcurrent tripping relay (set at 125 A). The same circuit breaker can be used at higher values of ambient temperature however, if suitably "derated". Thus, the circuit breaker in an ambient temperature of 50 °C could carry only 117 A indefinitely, or again, only 109 A at 60 °C, while complying with the specified temperature limit.

Derating a circuit breaker is achieved therefore, by reducing the trip-current setting of its overload relay, and marking the CB accordingly. The use of an electronic-type of tripping unit, designed to withstand high temperatures, allows circuit breakers (derated as described) to operate at 60 °C (or even at 70 °C) ambient.

Note: I_n for circuit breakers (in IEC 60947-2) is equal to I_u for switchgear generally, I_u being the rated uninterrupted current.

Frame-size rating

A circuit breaker which can be fitted with overcurrent tripping units of different current level-setting ranges, is assigned a rating which corresponds to the highest current-level-setting tripping unit that can be fitted.

Example

A Compact NSX630N circuit breaker can be equipped with 3 electronic trip units from 250 A to 630 A. The size of the circuit breaker is 630 A.

Overload relay trip-current setting (I_{rth} or I_r)

Apart from small circuit breakers which are very easily replaced, industrial circuit breakers are equipped with removable, i.e. exchangeable, overcurrent-trip relays. Moreover, in order to adapt a circuit breaker to the requirements of the circuit it controls, and to avoid the need to install over-sized cables, the trip relays are generally adjustable. The trip-current setting I_r or I_{rth} (both designations are in common use) is the current above which the circuit breaker will trip. It also represents the maximum current that the circuit breaker can carry without tripping. That value must be greater than the maximum load current I_B , but less than the maximum current permitted in the circuit I_z (see chapter G, sub-clause 1.3).

The thermal-trip relays are generally adjustable from 0.7 to 1.0 times I_n , but when electronic devices are used for this duty, the adjustment range is greater; typically 0.4 to 1 times I_n .

Example (see Fig. H27)

A NSX630N circuit breaker equipped with a 400 A Micrologic 6.3E overcurrent trip relay, set at 0.9, will have a trip-current setting:

$$I_r = 400 \times 0.9 = 360 \text{ A}$$

Note: For circuit breakers equipped with non-adjustable overcurrent-trip relays, $I_r = I_n$. Example: for iC60N 20 A circuit breaker, $I_r = I_n = 20$ A.

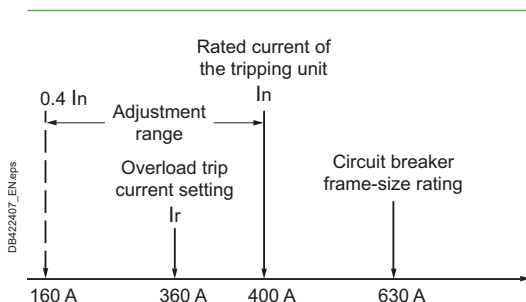


Fig. H27 Example of a Compact NSX630N circuit breaker with a Micrologic rated 400A adjusted to 0.9 to give $I_r = 360$ A

[1] Current-level setting values which refer to the current-operated thermal and "instantaneous" magnetic tripping devices for over-load and short-circuit protection.

4 Circuit breaker

Short-circuit relay trip-current setting (I_m)

Short-circuit tripping relays (instantaneous or slightly time-delayed) are intended to trip the circuit breaker rapidly on the occurrence of high values of fault current. Their tripping threshold I_m is:

- Either fixed by standards for domestic type CBs, e.g. IEC 60898, or,
- Indicated by the manufacturer for industrial type CBs according to related standards, notably IEC 60947-2.

For the latter circuit breakers there exists a wide variety of tripping devices which allow a user to adapt the protective performance of the circuit breaker to the particular requirements of a load (see Fig. H28, Fig. H29 and Fig. H30).

	Type of protective relay	Overload protection	Short-circuit protection		
			Low setting type B	Standard setting type C	High setting circuit type D
Domestic breakers IEC 60898	Thermal-magnetic	$I_r = I_n$	$3 I_n \leq I_m \leq 5 I_n$	$5 I_n \leq I_m \leq 10 I_n$	$10 I_n \leq I_m \leq 20 I_n^{[a]}$
Modular industrial ^[b] circuit breakers	Thermal-magnetic	$I_r = I_n$ fixed	Low setting type B or Z $3.2 I_n \leq \text{fixed} \leq 4.8 I_n$	Standard setting type C $7 I_n \leq \text{fixed} \leq 10 I_n$	High setting type D or K $10 I_n \leq \text{fixed} \leq 14 I_n$
Industrial ^[b] circuit breakers IEC 60947-2	Thermal-magnetic	$I_r = I_n$ fixed Adjustable: $0.7 I_n \leq I_r \leq I_n$	Fixed: $I_m = 7$ to $10 I_n$ Adjustable: - Low setting : 2 to $5 I_n$ - Standard setting: 5 to $10 I_n$		
	Electronic	Long delay $0.4 I_n \leq I_r \leq I_n$	Short-delay, adjustable $1.5 I_r \leq I_m \leq 10 I_r$ Instantaneous (I) fixed $I = 12$ to $15 I_n$		

[a] $50 I_n$ in IEC 60898, which is considered to be unrealistically high by most European manufacturers (Schneider Electric = 10 to 14 I_n).
 [b] For industrial use, IEC standards do not specify values. The above values are given only as being those in common use.

Fig. H28 Tripping-current ranges of overload and short-circuit protective devices for LV circuit breakers

H14

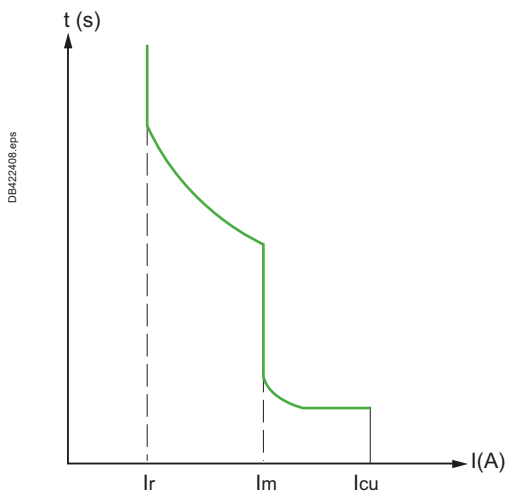
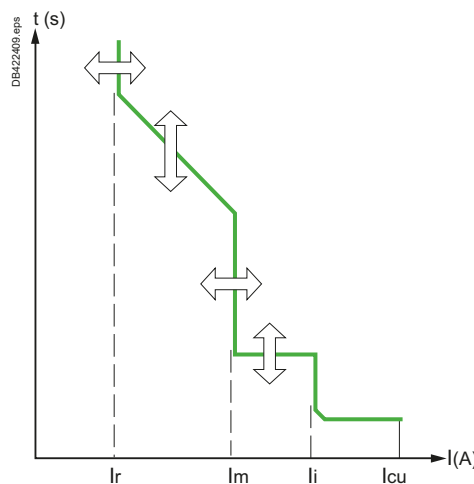


Fig. H29 Tripping curve of a thermal-magnetic circuit breaker




I_r : Overload (thermal or long-delay) relay trip-current setting
 I_m : Short-circuit (magnetic or short-delay) relay trip-current setting
 I_i : Short-circuit instantaneous relay trip-current setting.
 I_{cu} : Breaking capacity

Fig. H30 Tripping curve of a circuit breaker with advanced electronic trip unit

4 Circuit breaker

Circuit breaker suitable for isolation

A circuit breaker is suitable for isolating a circuit if it fulfills all the conditions prescribed for a disconnector (at its rated voltage) in the relevant standard (see sub-clause 1.2). In such a case it is referred to as a circuit breaker-disconnector and marked on its front face with the symbol 

All Acti 9, Compact NSX and Masterpact LV switchgear of Schneider Electric ranges are in this category.

The short-circuit current-breaking performance of a LV circuit breaker is related (approximately) to the $\cos \varphi$ of the fault-current loop. Standard values for this relationship have been established in some standards

Rated short-circuit breaking capacity (Icu or Icn)

The short-circuit current-breaking rating of a CB is the highest (prospective) value of current that the CB is capable of breaking without being damaged. The value of current quoted in the standards is the rms value of the AC component of the fault current, i.e. the DC transient component (which is always present in the worst possible case of short-circuit) is assumed to be zero for calculating the standardized value. This rated value (Icu) for industrial CBs and (Icn) for domestic-type CBs is normally given in kA rms.

Icu (rated ultimate s.c. breaking capacity) and Ics (rated service s.c. breaking capacity) are defined in IEC 60947-2 together with a table relating Ics with Icu for different categories of utilization A (instantaneous tripping) and B (time-delayed tripping) as discussed in subclause 4.3.

Tests for proving the rated s.c. breaking capacities of CBs are governed by standards, and include:

- Operating sequences, comprising a succession of operations, i.e. closing and opening on short-circuit
- Current and voltage phase displacement. When the current is in phase with the supply voltage ($\cos \varphi$ for the circuit = 1), interruption of the current is easier than that at any other power factor. Breaking a current at low lagging values of $\cos \varphi$ is considerably more difficult to achieve; a zero power-factor circuit being (theoretically) the most onerous case.

In practice, all power-system short-circuit fault currents are (more or less) at lagging power factors, and standards are based on values commonly considered to be representative of the majority of power systems. In general, the greater the level of fault current (at a given voltage), the lower the power factor of the fault-current loop, for example, close to generators or large transformers.

Fig. H31 below extracted from IEC 60947-2 relates standardized values of $\cos \varphi$ to industrial circuit breakers according to their rated Icu.

- Following an open - time delay - close/open sequence to test the Icu capacity of a CB, further tests are made to ensure that:
 - The dielectric withstand capability
 - The disconnection (isolation) performance and
 - The correct operation of the overload protection have not been impaired by the test.

Icu	cos φ
6 kA < Icu ≤ 10 kA	0.5
10 kA < Icu ≤ 20 kA	0.3
20 kA < Icu ≤ 50 kA	0.25
50 kA < Icu	0.2

Fig. H31 Icu related to power factor (cos φ) of fault-current circuit (IEC 60947-2)

4.3 Other characteristics of a circuit breaker

Rated insulation voltage (Ui)

This is the value of voltage to which the dielectric tests voltage (generally greater than 2 Ui) and creepage distances are referred to.

The maximum value of rated operational voltage must never exceed that of the rated insulation voltage, i.e. $U_e \leq U_i$.

4 Circuit breaker

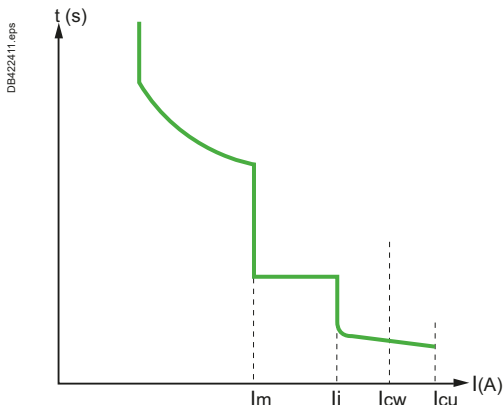


Fig. H32 Category B circuit breaker

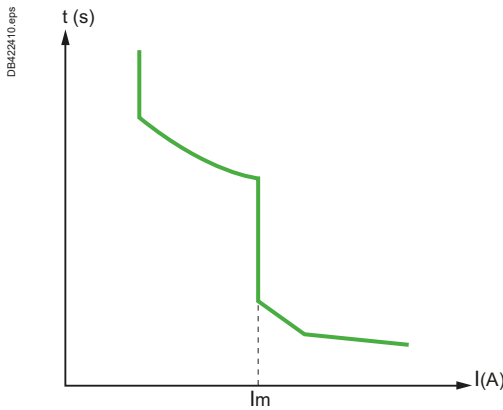


Fig. H33 Category A circuit breaker

Rated impulse-withstand voltage (Uimp)

This characteristic expresses, in kV peak (of a prescribed form and polarity) the value of voltage which the equipment is capable of withstanding without failure, under test conditions.

Generally, for industrial circuit breakers, $U_{imp} = 8 \text{ kV}$ and for domestic types, $U_{imp} = 6 \text{ kV}$.

Selectivity categories and rated short-time withstand current (Icw)

IEC 60947-2 defines two types of circuit breaker defined by their “selectivity category”:

■ **Selectivity category B** comprises circuit breakers providing selectivity by having a short-time withstand current rating and an associated short-time delay. For this category of circuit breaker, manufacturer shall provide the value of short-circuit current (I_{cw}) that can be withstood for a specified time.

It is possible to delay the tripping of this type circuit breaker, where the fault-current level is lower than this short-time withstand current rating (I_{cw}) (see Fig. H32). This is generally applied to power open type or “Air” circuit breakers and to certain heavy-duty molded-case types. I_{cw} is the maximum current that the B category circuit breaker can withstand, thermally and electro-dynamically, without sustaining damage, for a period of time given by the manufacturer.

■ **Selectivity category A** comprises all other circuit breakers. This category of circuit breaker has no deliberate delay in the operation of the “instantaneous” short-circuit magnetic tripping device (see Fig. H33). Usually molded-case type circuit breakers or modular circuit breaker are category A. These circuit breakers may provide selectivity under short-circuit conditions by other means. But manufacturer will not provide I_{cw} value.

Rated making capacity (Icm)

I_{cm} is the highest instantaneous value of current that the circuit breaker can establish at rated voltage in specified conditions. In AC systems this instantaneous peak value is related to I_{cu} (i.e. to the rated breaking current) by the factor k , which depends on the power factor ($\cos \phi$) of the short-circuit current loop (as shown in Fig. H34).

I_{cu}	$\cos \phi$	$I_{cm} = k I_{cu}$
$6 \text{ kA} < I_{cu} \leq 10 \text{ kA}$	0.5	$1.7 \times I_{cu}$
$10 \text{ kA} < I_{cu} \leq 20 \text{ kA}$	0.3	$2 \times I_{cu}$
$0 \text{ kA} < I_{cu} \leq 50 \text{ kA}$	0.25	$2.1 \times I_{cu}$
$50 \text{ kA} \leq I_{cu}$	0.2	$2.2 \times I_{cu}$

Fig. H34 Relation between rated breaking capacity I_{cu} and rated making capacity I_{cm} at different power-factor values of short-circuit current, as standardized in IEC 60947-2

Example: A Masterpact NW08H2 circuit breaker has a rated breaking capacity I_{cu} of 100 kA. The peak value of its rated making capacity I_{cm} will be $100 \times 2.2 = 220 \text{ kA}$.

Rated service short-circuit breaking capacity (Ics)

The rated breaking capacity (I_{cu}) or (I_{cn}) is the maximum fault-current a circuit breaker can successfully interrupt without being damaged. The probability of such a current occurring is extremely low, and in normal circumstances the fault-currents are considerably less than the rated breaking capacity (I_{cu}) of the CB. On the other hand it is important that high currents (of low probability) be interrupted under good conditions, so that the CB is immediately available for reclosure, after the faulty circuit has been repaired. It is for these reasons that a new characteristic (I_{cs}) has been created, expressed as a percentage of I_{cu} , viz: 25, 50, 75, 100% for industrial circuit breakers. The standard test sequence is as follows:

- O - CO - CO^[1] (at I_{cs})
- Tests carried out following this sequence are intended to verify that the CB is in a good state and available for normal service

For domestic CBs, $I_{cs} = k I_{cn}$. The factor k values are given in IEC 60898 table XIV.

In Europe it is the industrial practice to use a k factor of 100% so that $I_{cs} = I_{cu}$.

[1] O represents an opening operation.
CO represents a closing operation followed by an opening operation.

4 Circuit breaker

Many designs of LV circuit breakers feature a short-circuit current limitation capability, whereby the current is reduced and prevented from reaching its (otherwise) maximum peak value (see Fig. H35). The current-limitation performance of these CBs is presented in the form of graphs, typified by that shown in Fig. H36, diagram (a)

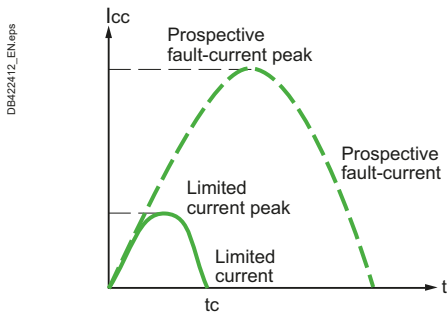


Fig. H35 Prospective and actual currents

Fault-current limitation

The fault-current limitation capacity of a CB concerns its ability, more or less effective, in preventing the passage of the maximum prospective fault-current, permitting only a limited amount of current to flow, as shown in Fig. H35. The current-limitation performance is given by the CB manufacturer in the form of curves (see Fig. H36).

■ Diagram (a) shows the limited peak value of current plotted against the rms value of the AC component of the prospective fault current ("prospective" fault-current refers to the fault-current which would flow if the CB had no current-limiting capability)

■ Limitation of the current greatly reduces the thermal stresses (proportional I^2t) and this is shown by the curve of diagram (b) of Fig. H36, again, versus the rms value of the AC component of the prospective fault current.

LV circuit breakers for domestic and similar installations are classified in certain standards (notably European Standard EN 60 898). CBs belonging to one class (of current limiters) have standardized limiting I^2t let-through characteristics defined by that class.

In these cases, manufacturers do not normally provide characteristic performance curves.

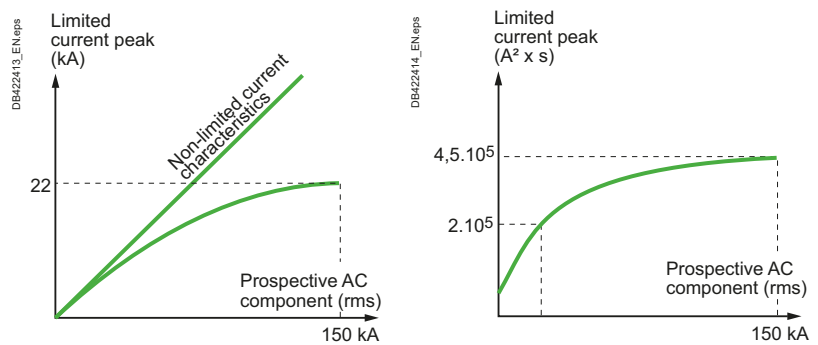


Fig. H36 Performance curves of a typical LV current-limiting circuit breaker

Current limitation reduces both thermal and electrodynamic stresses on all circuit elements through which the current passes, thereby prolonging the useful life of these elements. Furthermore, the limitation feature allows "cascading" techniques to be used (see 4.5) thereby significantly reducing design and installation costs

The advantages of current limitation

The use of current-limiting CBs affords numerous advantages:

- Better conservation of installation networks: current-limiting CBs strongly attenuate all harmful effects associated with short-circuit currents
- Reduction of thermal effects: Conductors (and therefore insulation) heating is significantly reduced, so that the life of cables is correspondingly increased
- Reduction of mechanical effects: forces due to electromagnetic repulsion are lower, with less risk of deformation and possible rupture, excessive burning of contacts, etc.
- Reduction of electromagnetic-interference effects:
 - Less influence on measuring instruments and associated circuits, telecommunication systems, etc.

These circuit breakers therefore contribute towards an improved exploitation of:

- Cables and wiring
- Prefabricated cable-trunking systems
- Switchgear, thereby reducing the ageing of the installation

Example

On a system having a prospective shortcircuit current of 150 kA rms, a Compact L circuit breaker limits the peak current to less than 10% of the calculated prospective peak value, and the thermal effects to less than 1% of those calculated.

Cascading of the several levels of distribution in an installation, downstream of a limiting CB, will also result in important savings.

The technique of cascading, described in sub-clause 4.5 allows, in fact, substantial savings on switchgear (lower performance permissible downstream of the limiting CB(s)) enclosures, and design studies, of up to 20% (overall).

Selective protection schemes and cascading are compatible, in the Compact NSX range, up to the full short-circuit breaking capacity of the switchgear.

4 Circuit breaker

The choice of a range of circuit breakers is determined by: the electrical characteristics of the installation, the environment, the loads and a need for remote control, together with the type of communications system envisaged

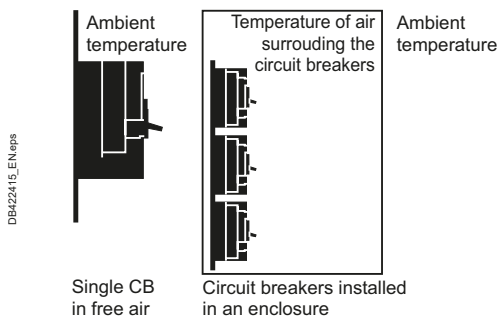


Fig. H37 Ambient temperature

Circuit breakers with uncompensated thermal tripping units have a trip current level that depends on the surrounding temperature

4.4 Selection of a circuit breaker

Choice of a circuit breaker

The choice of a CB is made in terms of:

- Electrical characteristics (AC or DC, Voltage...) of the installation for which the CB is intended
- Its environment: ambient temperature, in a kiosk or switchboard enclosure, climatic conditions, etc.
- Presumed short-circuit current at the point of installation
- Characteristics of the protected cables, busbars, busbar trunking system and application (distribution, motor...)
- Co-ordination with upstream and/or downstream device: selectivity, cascading, coordination with switch disconnecter, contactor...
- Operational specifications: requirements (or not) for remote control and indication and related auxiliary contacts, auxiliary tripping coils, connection
- Installation regulations; in particular: protection against electric shock and thermal effect (See Chapter F)
- Load characteristics, such as motors, fluorescent lighting, LED lighting, LV/LV transformers

The following notes relate to the choice LV circuit breaker for use in distribution systems.

Choice of rated current in terms of ambient temperature

The rated current of a circuit breaker is defined for operation at a given ambient temperature, in general:

- 30°C for domestic-type CBs according to IEC 60898 series
- 40°C by default for industrial-type CBs, according to IEC 60947 series. Different value may be proposed however.

Performance of these CBs in a different ambient temperature depends mainly on the technology of their tripping units (see Fig. H24).

Uncompensated thermal magnetic tripping units

Circuit breakers with uncompensated thermal tripping elements have a tripping-current level that depends on the surrounding temperature. If the CB is installed in an enclosure, or in a hot location (boiler room, etc.), the current required to trip the CB on overload will be sensibly reduced. When the temperature in which the CB is located exceeds its reference temperature, it will therefore be "derated".

For this reason, CB manufacturers provide tables which indicate factors to apply at temperatures different to the CB reference temperature. It may be noted from typical examples of such tables (see Fig. H39) that a lower temperature than the reference value produces an up-rating of the CB. Moreover, small modular-type CBs mounted in juxtaposition, as shown typically in Fig. H24, are usually mounted in a small closed metal case. In this situation, mutual heating, when passing normal load currents, generally requires them to be derated by a factor of 0.8.

Example

What rating (I_n) should be selected for a iC60N?

- Protecting a circuit, the maximum load current of which is estimated to be 34 A
- Installed side-by-side with other CBs in a closed distribution box
- In an ambient temperature of 60°C

A iC60N circuit breaker rated at 40 A would be derated to 38.2 A in ambient air at 60°C (see Fig. H39). To allow for mutual heating in the enclosed space, however, the 0.8 factor noted above must be employed, so that, $38.2 \times 0.8 = 30.5$ A, which is not suitable for the 34 A load.

A 50 A circuit breaker would therefore be selected, giving a (derated) current rating of $47.6 \times 0.8 = 38$ A.

Compensated thermal-magnetic tripping units

These tripping units include a bi-metal compensating strip which allows the overload trip-current setting (I_r or I_{rth}) to be adjusted, within a specified range, irrespective of the ambient temperature.

For example:

In certain countries, the TT system is standard on LV distribution systems, and domestic (and similar) installations are protected at the service position by a circuit breaker provided by the supply authority. This CB, besides affording protection against indirect-contact hazard, will trip on overload; in this case, if the consumer exceeds the current level stated in his supply contract with the power authority. The circuit breaker (≤ 60 A) is compensated for a temperature range of -5 °C to $+40$ °C.

4 Circuit breaker

Examples of tables giving the derated/uprated current values according to temperature, for circuit breakers with uncompensated thermal tripping units

Rating (A)	Ambient temperature (°C)												
	10	15	20	25	30	35	40	45	50	55	60	65	70
0.5	0.58	0.57	0.56	0.55	0.54	0.53	0.52	0.51	0.5	0.49	0.48	0.47	0.45
1	1.16	1.14	1.12	1.1	1.08	1.06	1.04	1.02	1	0.98	0.96	0.93	0.91
2	2.4	2.36	2.31	2.26	2.21	2.16	2.11	2.05	2	1.94	1.89	1.83	1.76
3	3.62	3.55	3.48	3.4	3.32	3.25	3.17	3.08	3	2.91	2.82	2.73	2.64
4	4.83	4.74	4.64	4.54	4.44	4.33	4.22	4.11	4	3.88	3.76	3.64	3.51
6	7.31	7.16	7.01	6.85	6.69	6.52	6.35	6.18	6	5.81	5.62	5.43	5.22
10	11.7	11.5	11.3	11.1	10.9	10.7	10.5	10.2	10	9.8	9.5	9.3	9
13	15.1	14.8	14.6	14.3	14.1	13.8	13.6	13.3	13	12.7	12.4	12.1	11.8
16	18.6	18.3	18	17.7	17.3	17	16.7	16.3	16	15.7	15.3	14.9	14.5
20	23	22.7	22.3	21.9	21.6	21.2	20.8	20.4	20	19.6	19.2	18.7	18.3
25	28.5	28.1	27.6	27.2	26.8	26.4	25.9	25.5	25	24.5	24.1	23.6	23.1
32	37.1	36.5	35.9	35.3	34.6	34	33.3	32.7	32	31.3	30.6	29.9	29.1
40	46.4	45.6	44.9	44.1	43.3	42.5	41.7	40.9	40	39.1	38.2	37.3	36.4
50	58.7	57.7	56.7	55.6	54.5	53.4	52.3	51.2	50	48.8	47.6	46.3	45
63	74.9	73.5	72.1	70.7	69.2	67.7	66.2	64.6	63	61.4	59.7	57.9	56.1

Fig. H38 iC60 (IEC 60947-2) - derated/uprated current values according to ambient temperature

Circuit breaker thermal characteristics are given considering the section and type of conductor (Cu or Al) according to IEC60947-1 Table 9 & 10 and IEC60898-1 & 2 Table 10

Rating (A)	Ambient temperature (°C)												
	10	15	20	25	30	35	40	45	50	55	60	65	70
16	18.4	18.7	18	18	17	16.6	16	15.6	15.2	14.8	14.5	14	13.8
25	28.8	28	27.5	25	26.3	25.6	25	24.5	24	23.5	23	22	21
32	36.8	36	35.2	34.4	33.6	32.8	32	31.3	30.5	30	29.5	29	28.5
40	46	45	44	43	42	41	40	39	38	37	36	35	34
50	57.5	56	55	54	52.5	51	50	49	48	47	46	45	44
63	72	71	69	68	66	65	63	61.5	60	58	57	55	54
80	92	90	88	86	84	82	80	78	76	74	72	70	68
100	115	113	110	108	105	103	100	97.5	95	92.5	90	87.5	85
125	144	141	138	134	131	128	125	122	119	116	113	109	106
160	184	180	176	172	168	164	160	156	152	148	144	140	136
200	230	225	220	215	210	205	200	195	190	185	180	175	170
250	288	281	277	269	263	256	250	244	238	231	225	219	213

Fig. H39 Compact NSX100-250 equipped with TM-D or TM-G trip units - derated/uprated current values according to ambient temperature

Electronic trip units

An important advantage with electronic tripping units is their stable performance in changing temperature conditions. However, the switchgear itself often imposes operational limits in elevated temperatures, so that manufacturers generally provide an operating chart relating the maximum values of permissible trip-current levels to the ambient temperature (see Fig. H40).

Moreover, electronic trip units can provide information that can be used for a better management of the electrical distribution, including energy efficiency and power quality.

Electronic tripping units are highly stable in changing temperature levels

Type of Drawout Masterpact	MT22 N1 - H1 - H2 - H3 -L1 -H10						
	08	10	12	16	20 [a]	20 [b]	
In front or rear horizontal	40	800	1000	1250	1600	2000	2000
	45						
	50						
	55						
	60						
	65						
	70						
In rear vertical	40	800	1000	1250	1600	2000	2000
	45						
	50						
	55						
	60						
	65						
	70						

[a] Type: H1/H2/H3

[b] Type: L1

Fig. H40 Derating of Masterpact MT22 circuit breaker, according to the temperature

4 Circuit breaker

H20

Selection of an instantaneous, or short-time-delay, tripping threshold

Fig. H41 below summarizes the main characteristics of the instantaneous or short-time delay trip units.

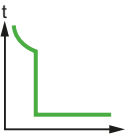
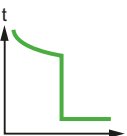
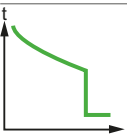

Type	Tripping unit	Applications
	Low setting type B	<ul style="list-style-type: none"> Sources producing low short-circuit-current levels (standby generators) Long lengths of line or cable
	Standard setting	<ul style="list-style-type: none"> Protection of circuits: general case
	High setting type C	<ul style="list-style-type: none"> Protection of circuits having high initial transient current levels (e.g. motors, transformers, resistive loads)
	12 In type MA	<ul style="list-style-type: none"> Protection of motors in association with contactors and overload protection

Fig. H41 Different tripping units, instantaneous or short-time-delayed

The installation of a LV circuit breaker requires that its short-circuit breaking capacity (or that of the CB together with an associated device) be equal to or exceeds the calculated prospective short-circuit current at its point of installation

Selection of a circuit breaker according to the presumed short-circuit current

The installation of a circuit breaker in a LV installation must fulfil one of the two following conditions:

- Either have a rated short-circuit breaking capacity I_{cu} (or I_{cn}) which is equal to or exceeds the prospective short-circuit current calculated for its point of installation, or
- If this is not the case, be associated with another device which is located upstream, and which has the required short-circuit breaking capacity

In the second case, the characteristics of the two devices must be co-ordinated such that the energy permitted to pass through the upstream device must not exceed that which the downstream device and all associated cables, wires and other components can withstand, without being damaged in any way.

This technique is profitably employed in:

- Associations of fuses and circuit breakers
- Associations of current-limiting circuit breakers. The technique is known as "cascading" (see sub-clause 4.5 of this chapter)


Circuit breakers suitable for IT systems

In IT system, circuit breakers may have to face an unusual situation called double earth fault when a second fault to earth occurs in presence of a first fault on the opposite side of a circuit breaker (see Fig. H42).

In that case circuit breaker has to clear the fault with phase to phase voltage across a single pole instead of phase to neutral voltage. Breaking capacity of the breaker may be modified in such a situation.

Annex H of IEC60947-2 deals with this situation and circuit breaker used in IT system shall have been tested according to this annex.

When a circuit breaker has not been tested according to this annex, a marking by

the symbol  shall be used on the nameplate.

Regulation in some countries may add additional requirements.

DB422437_EN_eps

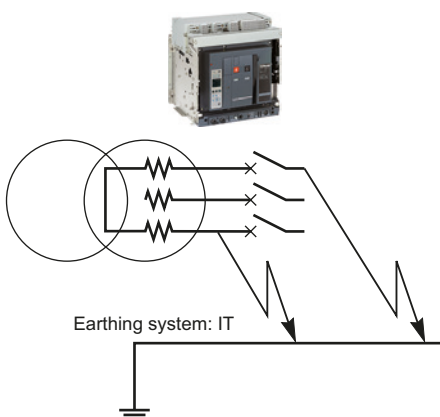


Fig. H42 Double earth fault situation

4 Circuit breaker

Selection of circuit breakers as main incomer and feeders:

Installation supplied by one transformer

If the transformer is located in a consumer's substation, certain national standards require a LV circuit breaker in which the open contacts are clearly visible such as withdrawable circuit breaker.

Example (see Fig. H43)

What type of circuit breaker is suitable for the main circuit breaker of an installation supplied through a 250 kVA MV/LV (400 V) 3-phase transformer in a consumer's substation?

I_n transformer = 360 A

I_{sc} (3-phase) = 9 kA

A Compact NSX400N with an adjustable tripping-unit range of 160 A - 400 A and a short-circuit breaking capacity (I_{cu}) of 50 kA would be a suitable choice for this duty.

Installation supplied by several transformers in parallel (see Fig. H44)

■ The feeder circuit breakers CBP must each be capable of breaking the total fault current from all transformers connected to the busbars: $I_{sc1} + I_{sc2} + I_{sc3}$

■ The main incomer circuit breakers CBM, must be capable of dealing with a maximum short-circuit current of (for example) $I_{sc2} + I_{sc3}$ only, for a short-circuit located on the upstream side of CBM1.

From these considerations, it will be seen that the circuit breaker of the smallest transformer will be subjected to the highest level of fault current in these circumstances, while the circuit breaker of the largest transformer will pass the lowest level of short-circuit current

■ The ratings of CBMs must be chosen according to the kVA ratings of the associated transformers

Note: The essential conditions for the successful operation of 3-phase transformers in parallel may be summarized as follows:

1. the phase shift of the voltages, primary to secondary, must be the same in all units to be paralleled.
 2. the open-circuit voltage ratios, primary to secondary, must be the same in all units.
 3. the short-circuit impedance voltage ($Z_{sc}\%$) must be the same for all units.
- For example, a 750 kVA transformer with a $Z_{sc} = 6\%$ will share the load correctly with a 1,000 kVA transformer having a Z_{sc} of 6%, i.e. the transformers will be loaded automatically in proportion to their kVA ratings. For transformers having a ratio of kVA ratings exceeding 2, parallel operation is not recommended.

Fig. H46 indicates, for the most usual arrangement (2 or 3 transformers of equal kVA ratings) the maximum short-circuit currents to which main and principal CBs (CBM and CBP respectively, in Figure H45) are subjected. It is based on the following hypotheses:

- The short-circuit 3-phase power on the MV side of the transformer is 500 MVA
- The transformers are standard 20/0.4 kV distribution-type units rated as listed
- The cables from each transformer to its LV circuit breaker comprise 5 metres of single core conductors
- Between each incoming-circuit CBM and each outgoing-circuit CBP there is 1 metre of busbar
- The switchgear is installed in a floor-mounted enclosed switchboard, in an ambient-air temperature of 30 °C

Example (see Fig. H45)

■ Circuit breaker selection for CBM duty:

For a 800 kVA transformer $I_n = 1155$ A; I_{cu} (minimum) = 38 kA (from Fig. H46), the CBM indicated in the table is a Compact NS1250N ($I_{cu} = 50$ kA)

■ Circuit breaker selection for CBP duty:

The s.c. breaking capacity (I_{cu}) required for these circuit breakers is given in the Fig. H46 as 56 kA.

A recommended choice for the three outgoing circuits 1, 2 and 3 would be current-limiting circuit breakers types NSX400 L, NSX250 L and NSX100 L. The I_{cu} rating in each case = 150 kA.

DB422421_EN.eps

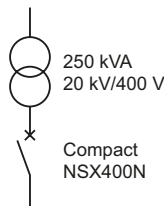


Fig. H43 Example of a transformer in a consumer's substation

DB422422_EN.eps

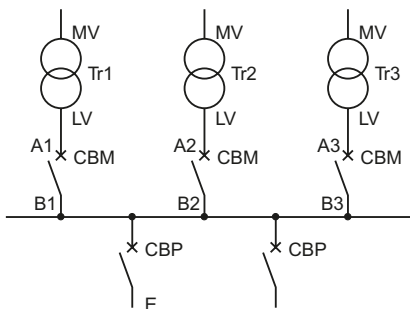


Fig. H44 Transformers in parallel

DB422423_EN.eps

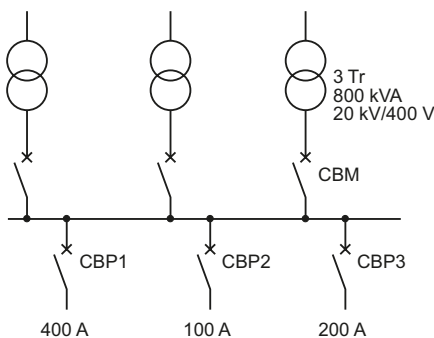


Fig. H45 Transformers in parallel

4 Circuit breaker

Number and kVA ratings of 20/0.4 kV transformers	Minimum S.C breaking capacity of main CBs (Icu) kA	Main circuit breakers (CBM) total selectivity with out going circuit breakers (CBP)	Minimum S.C breaking capacity of principal CBs (Icu) kA	Rated current In of principal circuit breaker (CPB) 250A
2 X 400	14	MTZ1 08H1 / MTZ2 08N1 / NS800N	28	NSX100-630F
3 X 400	28	MTZ1 08H1 / MTZ2 08N1 / NS800N	42	NSX100-630N
2 X 630	22	MTZ1 10H1 / MTZ2 10N1 / NS1000N	44	NSX100-630N
3 X 630	44	MTZ1 10H2 / MTZ2 10N1 / NS1000N	66	NSX100-630S
2 X 800	19	MTZ1 12H1 / MTZ2 12N1 / NS1250N	38	NSX100-630N
3 X 800	38	MTZ1 12H1 / MTZ2 12N1 / NS1250N	57	NSX100-630H
2 X 1000	23	MTZ1 16H1 / MTZ2 16N1 / NS1600N	46	NSX100-630N
3 X 1000	46	MTZ1 16H2 / MTZ2 16N1 / NS1600N	69	NSX100-630H
2 X 1250	29	MTZ2 20N1/NS2000N	58	NSX100-630H
3 X 1250	58	MTZ2 20H1/NS2000N	87	NSX100-630S
2 X 1600	36	MTZ2 25N1/NS2500N	72	NSX100-630S
3 X 1600	72	MTZ25 20H2/NS2500H	108	NSX100-630L
2 X 2000	45	MTZ2 32H1/NS3200N	90	NSX100-630S
3 X 2000	90	MTZ2 32H2	135	NSX100-630L

Fig. H46 Maximum values of short-circuit current to be interrupted by incomer and feeder circuit breakers (CBM and CBP respectively), for several transformers in parallel

These circuit breakers provide the advantages of:

- Total selectivity with the upstream (CBM) breakers
- Exploitation of the “cascading” technique, with its associated savings for all downstream components

Selection of feeder CBs and final-circuit CBs

Use of table Fig. G42

From this table, the value of 3-phase short-circuit current can be determined rapidly for any point in the installation, knowing:

- The value of short-circuit current at a point upstream of that intended for the CB concerned
- The length, c.s.a., and the composition of the conductors between the two points

A circuit breaker rated for a short-circuit breaking capacity exceeding the tabulated value may then be selected.

Detailed calculation of the short-circuit current level

In order to calculate more precisely the short-circuit current, notably, when the short-circuit current-breaking capacity of a CB is slightly less than that derived from the table, it is necessary to use the method indicated in chapter G clause 4.

Two-pole circuit breakers (for phase and neutral) with one protected pole only

These CBs are generally provided with an overcurrent protective device on the phase pole only, and may be used in TT, TN-S and IT schemes. In an IT scheme, however, the following conditions must be respected:

- Condition (B) of table in Fig. G68 for the protection of the neutral conductor against overcurrent in the case of a double fault
- Short-circuit current-breaking rating: a 2-pole phase-neutral CB must be capable of breaking on one pole (at the phase-to-phase voltage) the current of a double fault
- Protection against indirect contact: this protection is provided according to the rules for IT schemes

H22

Short-circuit fault-current levels at any point in an installation may be obtained from tables

4 Circuit breaker

4.5 Coordination between circuit breakers

Cascading or Back-up protection

Definition of the cascading technique

By limiting the peak value of short-circuit current passing through it, a current-limiting CB permits the use, in all circuits downstream of its location, of switchgear and circuit components having much lower short-circuit breaking capacities, and thermal and electromechanical withstand capabilities than would otherwise be necessary. Reduced physical size and lower performance requirements lead to substantial economy and to the simplification of installation work. It may be noted that, while a current-limiting circuit breaker has the effect on downstream circuits of (apparently) increasing the source impedance during short-circuit conditions, it has no such effect in any other condition; for example, during the starting of a large motor (where a low source impedance is highly desirable). The range of Compact NSX current-limiting circuit breakers with powerful limiting performances is particularly interesting.

Conditions of implementation

Most national standards admit the cascading technique, on condition that the amount of energy “let through” by the limiting CB is less than the energy all downstream CBs and components are able to withstand without damage.

In practice this can only be verified for CBs by tests performed in a laboratory. Such tests are carried out by manufacturers who provide the information in the form of tables, so that users can confidently design a cascading scheme based on the combination of recommended circuit breaker types. As an example, **Fig. H47** indicates the cascading possibilities of circuit breaker types iC60, C120 and NG125 when installed downstream of current-limiting CBs Compact NSX 250 N, H or L for a 230/400 V or 240/415 V 3-phase installation.

The technique of “cascading” uses the properties of current-limiting circuit breakers to permit the installation of all downstream switchgear, cables and other circuit components of significantly lower performance than would otherwise be necessary, thereby simplifying and reducing the cost of an installation

In general, laboratory tests are necessary to ensure that the conditions of implementation required by national standards are met and compatible switchgear combinations must be provided by the manufacturer

H23

Upstream CB			NSX250					
			B	F	N	H	S	L
Icu (kA)			25	36	50	70	100	150
Downstream CB								
Type	Rating (A)	Icu (kA)	Reinforced breaking capacity (kA)					
iDPN ^[a]	1-40	6	10	10	10	10	10	10
iDPN N ^[a]	1-16	10	20	20	20	20	20	20
	25-40	10	16	16	16	16	16	16
iC60N	0,5-40	10	20	25	30	30	30	30
	50-63	10	20	25	25	25	25	25
iC60H	0,5-40	15	25	30	30	30	30	30
	50-63	15	25	25	25	25	25	25
iC60L	0,5-25	25	25	30	30	30	30	30
	32-40	20	25	30	30	30	30	30
	50-63	15	25	25	25	25	25	25
C120N	63-125	10	25	25	25	25	25	25
C120H	63-125	15	25	25	25	25	25	25
NG125N	1-125	25		36	36	36	50	70
NG125H	1-125	36			40	50	70	100
NG125L	1-80	50			50	70	100	150

[a] 230 V phase to neutral

Note: for up-to-date cascading values, refer to manufacturer’s documentation, such as Schneider Electric’s “[Complementary Technical Information](#)”.

Fig. H47 Example of cascading possibilities on a 230/400 V or 240/415 V 3-phase installation

Advantages of cascading

The current limitation benefits all downstream circuits that are controlled by the current-limiting CB concerned.

The principle is not restrictive, i.e. current-limiting CBs can be installed at any point in an installation where the downstream circuits would otherwise be inadequately rated.

The result is:

- Simplified short-circuit current calculations
- Simplification, i.e. a wider choice of downstream switchgear and appliances
- The use of lighter-duty switchgear and appliances, with consequently lower cost
- Economy of space requirements, since light-duty equipment have generally a smaller volume

4 Circuit breaker

Selectivity is essential to ensure continuity of supply and fast fault localization.

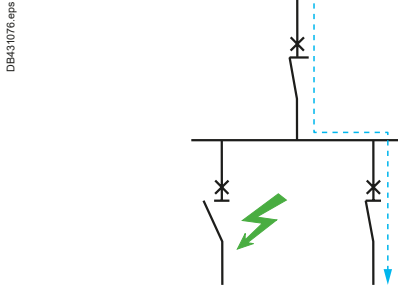


Fig. H48 Principle of selectivity

Principles of Selectivity

Selectivity is achieved by overcurrent and earth fault protective devices if a fault condition, occurring at any point in the installation, is cleared by the protective device located immediately upstream of the fault, while all other protective devices remain unaffected (see Fig. H48).

Selectivity is required for installation supplying critical loads where one fault on one circuit shall not cause the interruption of the supply of other circuits. In IEC 60364 series it is mandatory for installation supplying safety services (IEC60364-5-56 2009 560.7.4). Selectivity may also be required by some local regulation or for some special application like :

- Medical location
- Marine
- High-rise building

Selectivity is highly recommended where continuity of supply is critical due to the nature of the loads.

- Data center
- Infrastructure (tunnel, airport...)
- Critical process

From installation point of view: Selectivity is achieved when the maximum short-circuit current at a point of installation is below selectivity limit of the circuit breakers supplying this point of installation. Selectivity shall be checked for all circuits supplied by one source and for all type of fault:

- Overload
- Short-circuit
- Earth fault

When system can be supplied by different sources (Grid or generator set for instance) selectivity shall be checked in both cases.

Selectivity between two circuit breakers may be

- Total : up to the breaking capacity of the downstream circuit breaker
- Partial : up to a specified value according to circuit breakers characteristics

Fig. H49, Fig. H50, Fig. H51

Different solution are provided to achieve selectivity based on:

- Current
- Time
- Energy
- Logic

Current based selectivity

see (a) of Fig. H52

This method is realized by setting successive tripping thresholds at stepped levels, from downstream circuits (lower settings) towards the source (higher settings). Selectivity is total or partial, depending on particular conditions, as noted above.

Time based selectivity

see (b) of Fig. H52

This method is implemented by adjusting the time-delayed tripping units, such that downstream relays have the shortest operating times, with progressively longer delays towards the source. In the two-level arrangement shown, upstream circuit breaker A is delayed sufficiently to ensure total selectivity with B (for example: Masterpact with electronic trip unit).

Selectivity category B circuit breakers are designed for time based selectivity, the selectivity limit will be the upstream short time withstand value (Icw)

Selectivity based on a combination of the two previous methods

see (c) of Fig. H52

A time-delay added to a current level scheme can improve the overall selectivity performance.

The upstream CB has two magnetic tripping thresholds:

- $I_m A$: delayed magnetic trip or short-delay electronic trip
- I_i : instantaneous trip

Selectivity is total if $I_{sc B} < I_i$ (instantaneous).

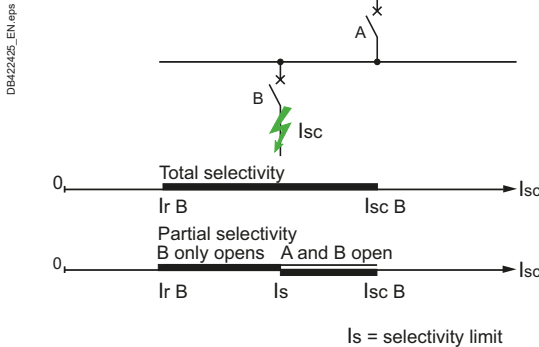


Fig. H49 Total and partial selectivity

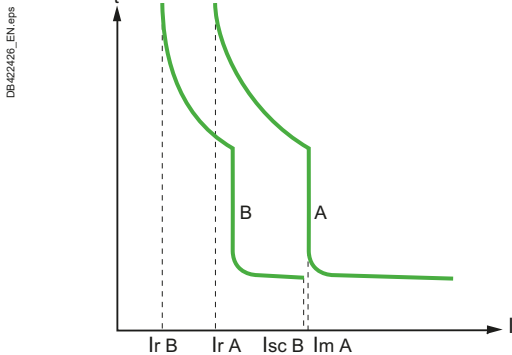


Fig. H50 Total selectivity between CBs A and B

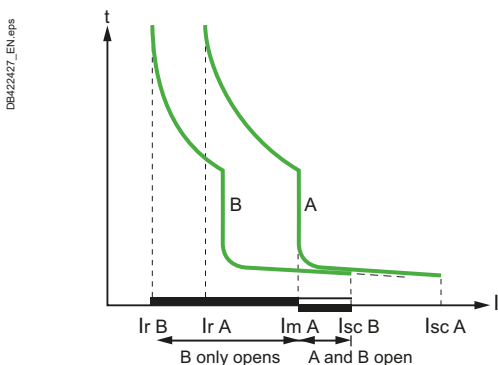


Fig. H51 Partial selectivity between CBs A and B

H - LV switchgear: functions & selection

4 Circuit breaker

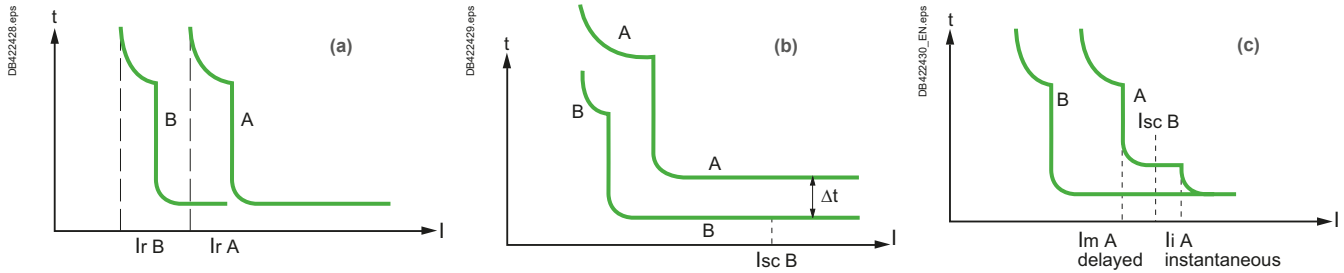


Fig. H52 Current based selectivity, Time based selectivity, Combination of both

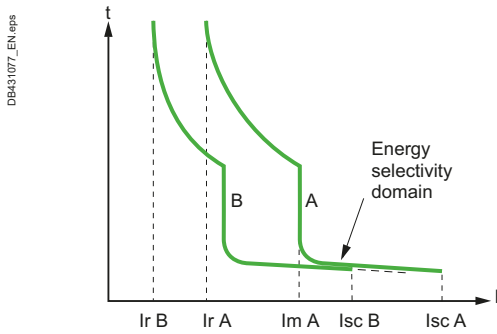


Fig. H53 Energy based selectivity

Protection against high level short-circuit currents: Selectivity based on arc-energy levels

Where time versus current curves are superposed selectivity is possible with limiter circuit breaker when they are properly coordinated.

Principle: When a very high level short-circuit current is detected by the two circuit breakers A and B, their contacts open simultaneously. As a result, the current is highly limited.

- The very high arc-energy at level B induces the tripping of circuit breaker B
- Then, the arc-energy is limited at level A and is not sufficient to induce the tripping of A

This approach requires an accurate coordination of limitation levels and tripping energy levels. It's implemented inside the Compact NSX range (current limiting circuit breaker), and between compact NSX and acti 9 range. This solution is the only one to achieve selectivity up to high short-circuit current with selectivity category A circuit breaker according to IEC60947-2.

H25

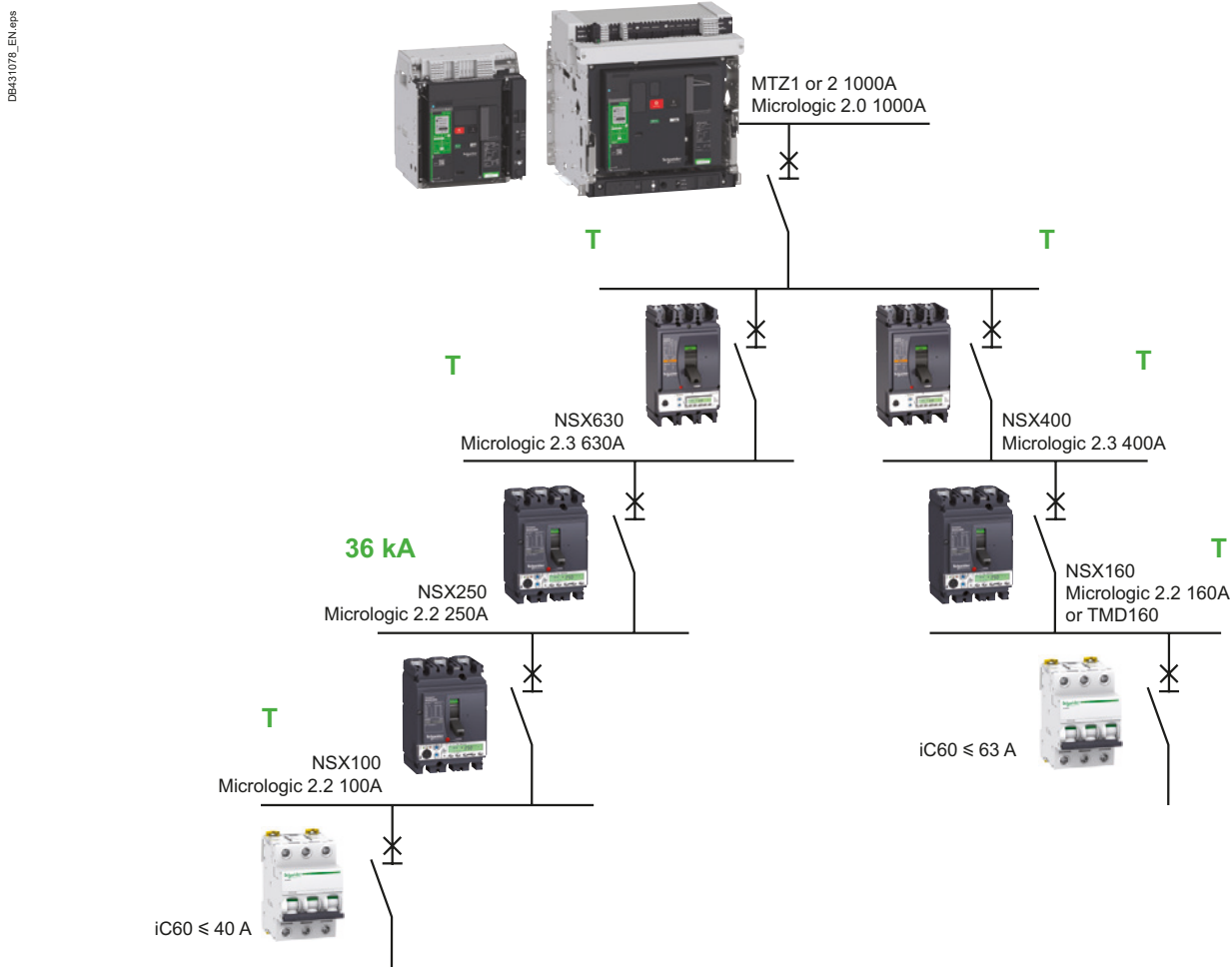


Fig. H54 Practical example of selectivity at several levels with Schneider Electric circuit breakers (with electronic trip units)

4 Circuit breaker

H26

Selectivity schemes based on logic techniques are possible, using CBs equipped with electronic tripping units designed for the purpose (Compact, Masterpact) and interconnected with pilot wires.

Selectivity enhanced by cascading

Cascading between 2 devices is normally achieved by using the tripping of the upstream circuit breaker A to help the downstream circuit breaker B to break the current. By principle cascading is in contradiction with selectivity. But the energy selectivity technology implemented in Compact NSX circuit-breakers allows to improve the breaking capacity of downstream circuit-breakers and keep at the same time a high selectivity performance.

The principle is as follows:

- The downstream limiting circuit breaker B sees a very high short-circuit current. The tripping is very fast (<1 ms) and then, the current is limited
- The upstream circuit breaker A sees a limited short-circuit current compared to its breaking capability, but this current induces a repulsion of the contacts. As a result, the arcing voltage increases the current limitation. However, the arc energy is not high enough to induce the tripping of the circuit breaker. So, the circuit breaker A helps the circuit breaker B to trip, without tripping itself. The selectivity limit can be higher than Icu B and the selectivity becomes total with a reduced cost of the devices

Logic selectivity or “Zone Sequence Interlocking – ZSI”

This type of selectivity can be achieved with circuit breakers equipped with specially designed electronic trip units (Compact, Masterpact): only the Short Time Protection (I_{sd}, T_{sd}) and Ground Fault Protection (GFP) functions of the controlled devices are managed by Logic Selectivity. In particular, the Instantaneous Protection function is not concerned.

One benefit of this solution is to have a short tripping time wherever is located the fault with selectivity category B circuit breaker. Time based selectivity on multi level system implies long tripping time at the origin of the installation.

Settings of controlled circuit breakers

- time delay: Staging of the time delays is necessary at least for circuit breaker receiving a ZSI Input ($\Delta tD1 > \text{trip time with no delay of } D2$ and $\Delta tD2 > \text{trip time with no delay of } D3$)
- thresholds: there are no threshold rules to be applied, but natural staging of the protection device ratings must be complied with ($I_{crD1} > I_{crD2} > I_{crD3}$).

Note: This technique ensures selectivity even with circuit breakers of similar ratings.

Principles

Activation of the Logic Selectivity function is via transmission of information on the pilot wire:

- ZSI input:
 - low level (no downstream faults): the Protection function is on standby with no time delay,
 - high level (presence of downstream faults): the relevant Protection function moves to the time delay status set on the device.
- ZSI output:
 - low level: the trip unit detects no faults and sends no orders,
 - high level: the trip unit detects a fault and sends an order.

Operation

A pilot wire connects in cascading form the protection devices of an installation (see Fig. H55). **When a fault occurs, each circuit breaker** upstream of the fault (detecting a fault) sends an order (high level output) and moves the upstream circuit breaker to its set time delay (high level input). The circuit breaker placed just above the fault does not receive any orders (low level input) and thus trips almost instantaneously.

DB422434_EN.eps

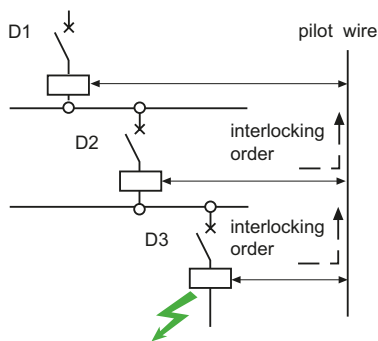


Fig. H55 Logic selectivity.

4 Circuit breaker

DB422435_EN.eps

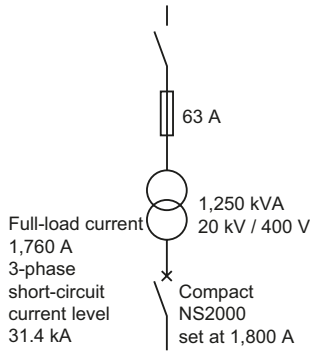


Fig. H56 Example

4.6 Selectivity MV/LV in a consumer's substation

In general the transformer in a consumer's substation is protected by MV fuses, suitably rated to match the transformer, in accordance with the principles laid down in IEC 60787 and IEC 60420, by following the advice of the fuse manufacturer.

The basic requirement is that a MV fuse will not operate for LV faults occurring downstream of the transformer LV circuit breaker, so that the tripping characteristic curve of the latter must be to the left of that of the MV fuse pre-arcing curve.

This requirement generally fixes the maximum settings for the LV circuit breaker protection:

- Maximum short-circuit current-level setting of the magnetic tripping element
- Maximum time-delay allowable for the short-circuit tripping element (see **Fig. H56**)

Example:

- Short-circuit level at MV terminals of transformer: 250 MVA
- Transformer MV/LV: 1,250 kVA 20/0.4 kV
- MV fuses: 63 A
- Cabling, transformer - LV circuit breaker: 10 metres single-core cables
- LV circuit breaker: Compact NS 2000 set at 1,800 A (I_r)

What is the maximum short-circuit trip current setting and its maximum time delay allowable?

The curves of **Fig. H57** show that selectivity is assured if the short-time delay tripping unit of the CB is set at:

- A level $\leq 6 I_r = 10.8 \text{ kA}$
- A time-delay setting of step 1 or 2.

DB422436_EN.eps

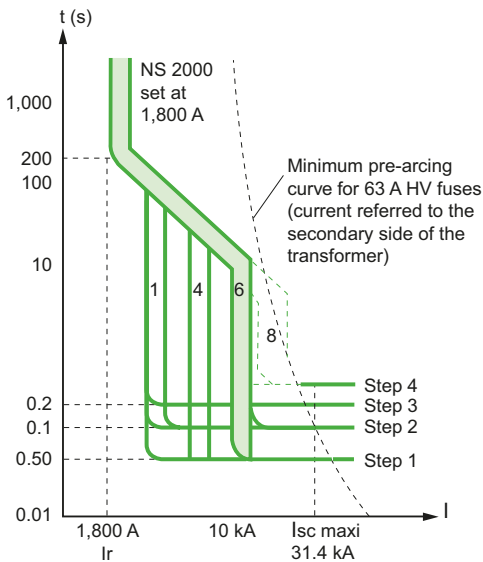


Fig. H57 Curves of MV fuses and LV circuit breaker

4 Circuit breaker

4.7 Ultra rapid circuit breaker

As installed power increases, electrical distribution has to shift from a LV design to a HV design. Indeed, a high short-circuit level can be a threat to the installation and make impossible the selection of low voltage equipments (Switchboard and bus bars, circuit breaker...)

These situations could be met in the following applications: Bus bars coupling onboard merchant vessels, off shore platform, loop networks (in industry), where the current and energy are important because of the installed power (several transformers or generators in parallel) and HV design not easy.

Two solutions could be used:

- **Pyrotechnic interruption switching device**
- **Power circuit breaker based solution**

Some power circuit breakers with additional feature (based on the Thomson effect technology for instance) provide an ultra rapid opening system on very high short-circuit level (see [Fig. H58](#)). The breaking performance makes it possible to limit the prospective short-circuit current and energy, and consequently protect the electrical installation against the electrodynamic and thermal effects of short-circuit.

PH101894_SCEZ.496

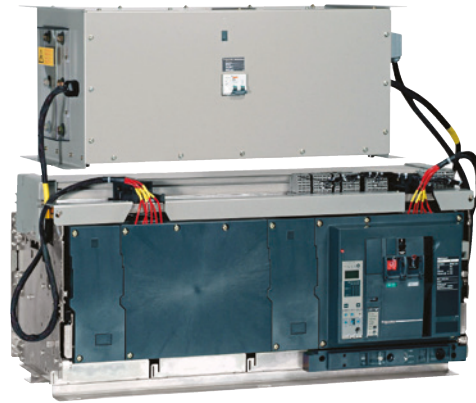


Fig. H58 Example of ultra rapid power circuit breaker: Masterpact UR (Schneider Electric)

4 Circuit breaker

Example of limitation offered by Masterpact UR in decoupling bus bars in case of short circuit (see Fig. H59):

When a short-circuit occurs downstream in the installation (A) with no tie breaker, the short-circuit level will be the result of the total generated power (illustrated by curve 1).

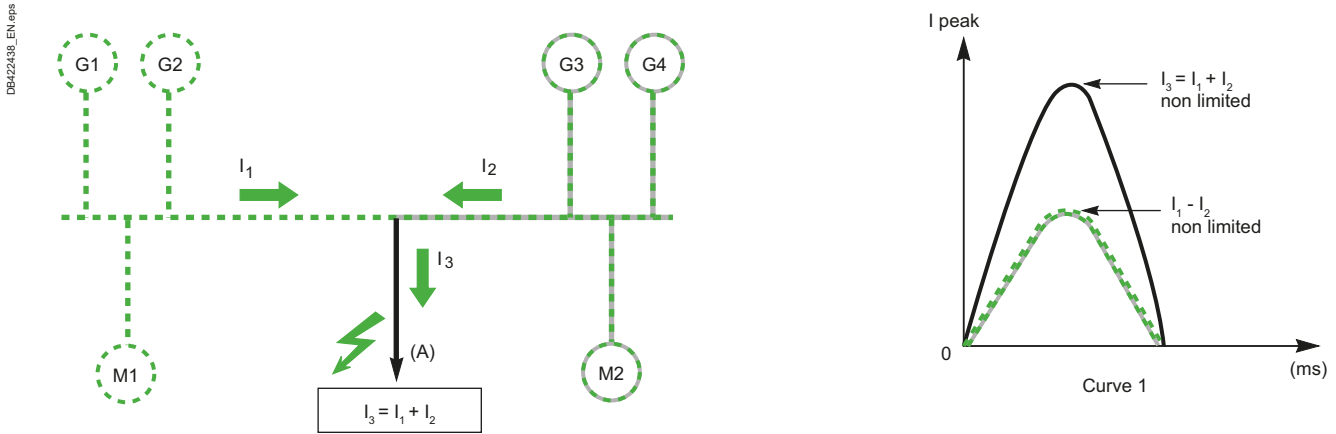


Fig. H59 Diagram of the network

By inserting a tie breaker (see Fig. H60) - Masterpact UR - to separate the sources under fault conditions, the short circuit at (A) will consist in:

- a limited short circuit coming from generator G1 and G2 interrupted by the Masterpact UR (see curve 2)
- a non limited short circuit from generators G3 and G4 (see curve 3).

H29

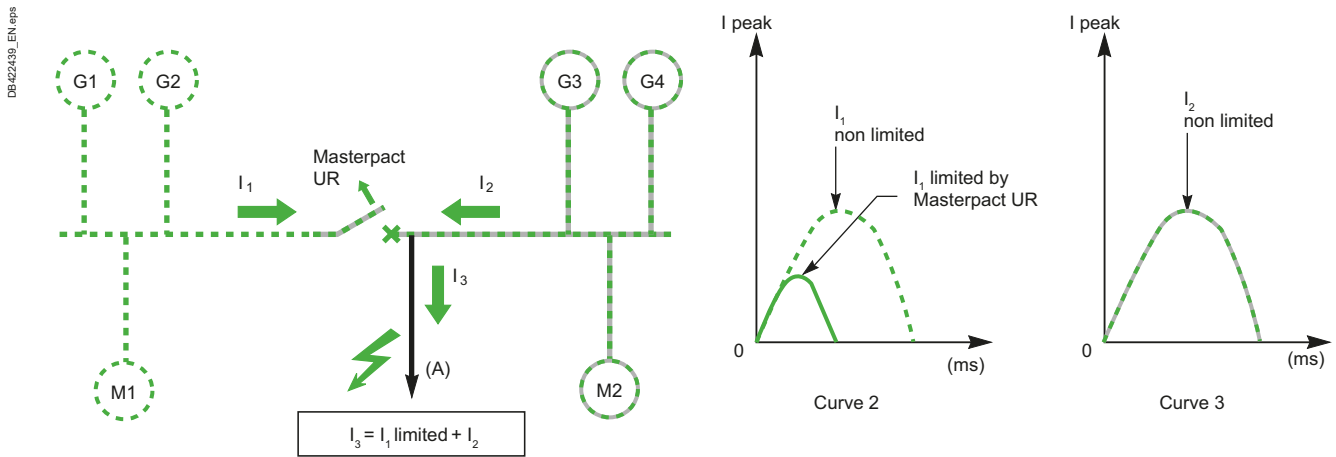


Fig. H60 Diagram of the network with Masterpact UR added as tie breaker

4 Circuit breaker

The resulting short circuit current is illustrated by curve 4 (see Fig. H61):

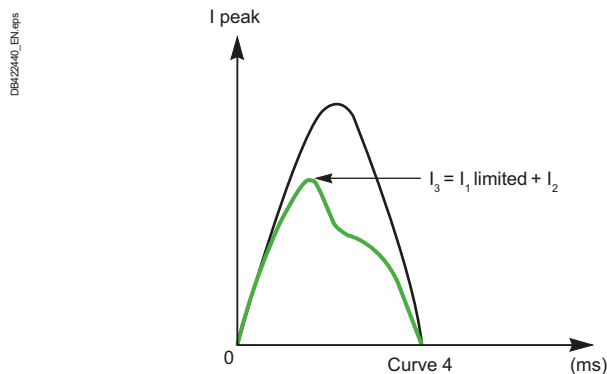


Fig. H61 Resulting short-circuit current

The consequence of the strong limitation of the short circuit current and the prospective energy allows the design of a LV network instead of a MV design.

This also prevents the network from being totally shutdown (black out) in case of short circuit in the main switchboard.

The following table (Fig. H62) give some example of limitation with Masterpact UR as a tie breaker between source 1 & 2

Source 2	Source 1																							
	50	55	60	65	70	75	80	85	90	95	100	110												
50	169	207	183	229	193	240	203	251	213	262	224	273	234	284	244	295	254	306	264	317	274	317	295	349
55	176	229	189	240	199	251	210	262	220	273	230	284	240	295	250	306	260	317	270	327	281	338	301	360
60	178	240	191	251	201	262	211	273	220	284	230	295	240	306	249	317	259	327	262	338	272	349	298	371
65	181	251	194	262	204	273	214	284	223	295	233	306	242	317	252	327	262	338	272	349	281	360	301	382
70	185	262	198	273	207	284	217	295	226	306	236	317	246	327	255	338	265	349	275	360	284	371	304	393
75	189	273	201	284	211	295	220	306	230	317	240	327	249	338	259	349	268	360	278	371	288	382	307	404
80	192	284	205	295	214	306	224	317	233	327	243	338	252	349	262	360	272	371	281	382	291	393	310	415
85	196	295	208	306	218	317	227	327	237	338	246	349	256	360	265	371	275	382	284	393	294	404	313	426
90	199	306	212	317	221	327	231	338	240	349	249	349	259	371	268	382	278	393	288	404	297	415	316	437
95	204	317	216	327	225	338	235	349	244	360	253	371	263	382	272	393	382	404	291	415	301	426	320	448
100	209	327	221	338	230	349	239	360	249	371	258	382	268	393	277	404	287	415	296	426	306	437	325	458
110	218	349	230	360	239	371	248	382	258	393	267	404	276	415	286	426	295	437	305	448	314	458	333	480

- Non limited short-circuit current
- Limited short-circuit current with Masterpact UR

Fig. H62 Example of limitation by Masterpact UR for 690 V - 60 Hz network

5 Maintenance of low voltage switchgear

IEC60364-6 requires initial and periodic verifications of electrical installations. The electrical switchboard and all its equipment continue to age whether they operate or not. This aging process is due mainly to environmental influences and operating conditions. To ensure that Low voltage switchgear and especially circuit breaker retains the operating and safety characteristics specified in the catalogue for the whole of its service life, it is recommended that:

- The device is installed in optimum environmental and operating conditions
- Routine inspections and regular maintenance are carried out by qualified personnel.

Parameters influencing the ageing

A device placed in given conditions is subjected to its effects. The main factors that accelerate device ageing are:

- temperature
- vibration
- relative humidity
- salt environment
- dust
- corrosive atmospheres.
- percent load
- current harmonics.

Preventive maintenance

Preventive maintenance consists in carrying out, at predetermined intervals or according to prescribed criteria, checks intended to reduce the probability of a failure or deterioration in the operation of a system.

There are two types of preventive maintenance:

■ Periodic maintenance

For each type of product, maintenance recommendations have to be formalized in a dedicated document by the technical department. These verification procedures, intended to maintain systems or their subassemblies in correct operating condition over the targeted service life, must then be carried out according to the time intervals stipulated in this document.

■ Conditional maintenance

To a certain extent, conditional-maintenance operations are a means to reduce (but not eliminate) the recommended periodic-maintenance operations (thus limited to the strict minimum) that require an annual shutdown of the installation.

These operations are launched when programmed alarms indicate that a redefined threshold has been reached. (Number of operation > durability, aging indicators...) Electronic trip units in power circuit breaker can propose such functions. Conditional maintenance is the means to optimise installation maintenance.

Example of maintenance recommendation for Power Circuit Breaker (>630 A)

The table below indicates maintenance operations and their intervals:

Interval	Maintenance operations
1 year	Visual inspection and functional testing, replacement of faulty accessories
2 years	+ servicing operation and subassembly tests
5 years	+ diagnostics and repairs (by manufacturer)

Fig. H63 Recommended periodic maintenance operations, for normal operating conditions

The intervals stated are for normal environmental and operating conditions.

Provided **all** the environmental conditions are more favourable, maintenance intervals can be longer.

If **just one** of the conditions is more severe, maintenance must be carried out more frequently.

Functions linked specifically to safety require particular intervals. For example, emergency switching and earth leakage protection.

5 Maintenance of low voltage switchgear

The case

The case is an essential element in the circuit breaker.

First of all, it ensures a number of safety functions:

- functional insulation between the phases themselves and between the phases and the exposed conductive parts in order to resist transient overvoltages caused by the distribution system
- a barrier avoiding direct user contact with live parts
- protection against the effects of electrical arcs and overpressures caused by short-circuits.

Secondly, it serves to support the entire pole operating mechanism as well as the mechanical and electrical accessories of the circuit breaker.

On the case, there should be:

- no traces of grime (grease), excessive dust or condensation which all reduce insulation
- no signs of burns or cracks which would reduce the mechanical solidity of the case and thus its capacity to withstand short-circuits.

Preventive maintenance for cases consists of a visual inspection of its condition and cleaning with a dry cloth or a vacuum cleaner. All cleaning products with solvents are strictly forbidden. It is advised to measure the insulation every five years and following trips due to a short-circuit. The product must be replaced if there are signs of burns or cracks.

Arc chutes (for Air Circuit breaker)

During a short-circuit, the arc chute serves to extinguish the arc and to absorb the high level of energy along the entire path of the short-circuit. It also contributes to arc extinction under rated current conditions. An arc chute that is not in good condition may not be capable of fully clearing the short-circuit and ultimately result in the destruction of the circuit breaker. The arc chutes for air circuit breaker must be regularly checked. The fins of the arc chutes may be blackened but must not be significantly damaged. What is more, the filters must not be blocked to avoid internal overpressures. It is advised to use a vacuum cleaner rather than a cloth to remove dust from the outside of the arc chutes.

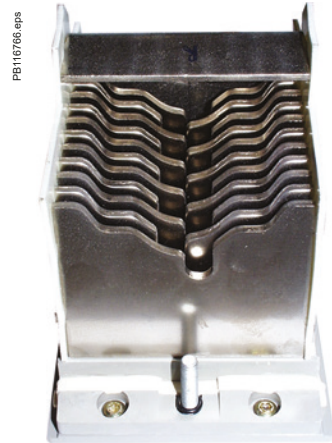


Fig. H64 Example of maintenance recommendation for Power Circuit Breaker (> 630 A)

5 Maintenance of low voltage switchgear

Main contacts (for Air Circuit breaker)

The contacts make and break the current under normal conditions (rated current for the installation) and under exceptional conditions (overloads and short-circuits). The contacts are eroded by the many opening and closing cycles and can be particularly deteriorated by short-circuit currents.

Worn contacts may result in abnormal temperature rise and accelerate device ageing.

It is imperative to remove the arc chutes and visually check contact wear at least once a year and following each short-circuit.

The contact-wear indicators constitute an absolute minimum value that must not be overruled.

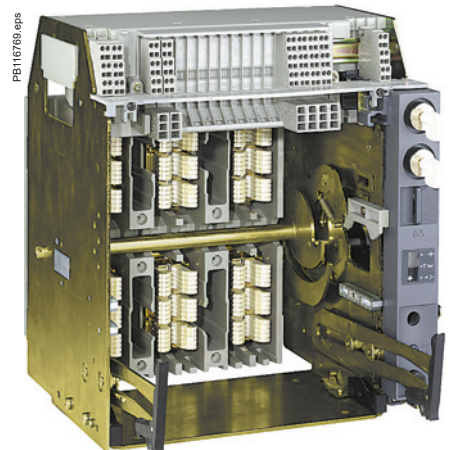
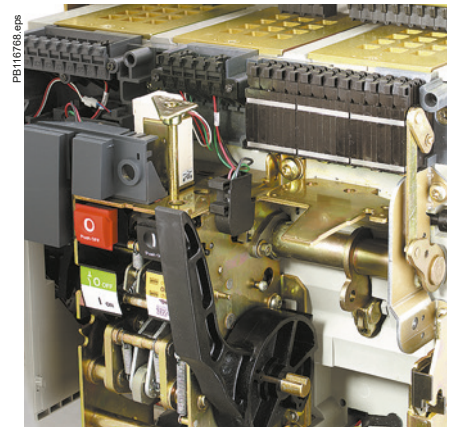


Device and chassis mechanisms

Mechanical operation of the circuit breaker may be hindered by dust, knocks, aggressive atmospheres, no greasing or excessive greasing. Operating safety is ensured by dusting and general cleaning, proper greasing and regular opening and closing of the circuit breaker.

The imperative need to ensure continuity of service in an installation generally means that power circuit breakers are rarely operated. If, on the one hand, an excessive number of operating cycles accelerates device ageing, it is also true that a lack of operation over a long period can result in mechanical malfunctions. Regular operation is required to maintain the normal performance level of each part involved in the opening and closing cycles.

In installations where power circuit breakers are used in source changeover systems, it is advised to periodically operate the circuit breaker for the alternate source.



H33

Fig. H64 Example of maintenance recommendation for Power Circuit Breaker (> 630 A)

5 Maintenance of low voltage switchgear

Electronic trip unit

If an electric fault occurs in the installation, the electronic trip unit detects the fault and orders the circuit breaker to open and thus protect life and property. Electronic components and circuit boards are sensitive to the environment (ambient temperature, humid and corrosive atmospheres) and to severe operating conditions (magnetic fields, vibrations, etc.). To ensure correct operation, it is necessary to periodically check:

- the chain of action resulting in a trip
 - the response time as a function of the level of the fault current.
- Depending on the operating and environment conditions, it is advised to estimate the service life of trip units, and to replace them if necessary to avoid any risk of non-operation when they are needed.



Auxiliary circuits

Control auxiliaries

MX and XF shunt releases are respectively used to remotely open and close the circuit breaker using an electrical order or by a supervisor via a communication network.

The MN undervoltage release is used to break the power circuit if the distribution system voltage drops or fails in order to protect life (emergency off) or property.

Preventive maintenance consists in periodically checking operation at minimum values. Depending on the operating and environment conditions, it is advised to estimate their service life and to replace them if necessary to avoid any risk of non-operation when they are needed.

Auxiliary wiring

Auxiliary wiring is used to transmit orders to the various control devices and to transmit status-condition information. Incorrect connections or damaged insulation may result in either non-operation of the circuit breaker or nuisance tripping.

Auxiliary wiring must be regularly checked and replaced as needed, particularly if there are vibrations, high ambient temperatures or corrosive atmospheres.

Indication contacts

The contacts indicating the status of the circuit breaker (ON / OFF), of the chassis (CE, CD, CT), a trip due to an electrical fault (SDE) or that the circuit breaker is ready to close (PF) provide the operator with the status information required to react correspondingly. Any incorrect indications may result in erroneous device operation that could endanger life and property. Contact failure (wear, loose connections) may result from vibrations, corrosion or abnormal temperature rise and preventive maintenance must ensure that contacts correctly conduct or isolate according to their positions.

Gear motor

The gear motor (MCH) automatically recharges the operating-mechanism springs as soon as the circuit breaker is closed. The gear motor makes it possible to instantaneously reclose the device following an opening. This function may be indispensable for safety reasons. The charging lever serves simply as a backup means if the auxiliary voltage fails. Given the mechanical forces exerted to charge the mechanism, the gear motor wears quickly. Periodic checks on gear-motor operation and the charging time are required to ensure the device closing function.

Fig. H64 Example of maintenance recommendation for Power Circuit Breaker (> 630 A)

H34

1	Overvoltage of atmospheric origin	J2
	1.1 Overvoltage definitions	J2
	1.2 Overvoltage characteristics of atmospheric origin	J3
	1.3 Effects on electrical installations	J3
	1.4 Characterization of the lightning wave	J6
2	Principle of lightning protection	J7
	2.1 General rules	J7
	2.2 Building protection system	J7
	2.3 Electrical installation protection system	J9
	2.4 The Surge Protection Device (SPD)	J10
3	Design of the electrical installation protection system	J13
	3.1 Design rules	J13
	3.2 Elements of the protection system	J14
	3.3 Common characteristics of SPDs according to the installation characteristics	J16
	3.4 Selection of a Type 1 SPD	J19
	3.5 Selection of a Type 2 SPD	J19
	3.6 Selection of external Short Circuit Protection Device (SCPD)	J20
	3.7 SPD and protection device coordination table	J22
4	Installation of SPDs	J24
	4.1 Connection	J24
	4.2 Cabling rules	J26
5	Application	J28
	5.1 Installation examples	J28
	5.2 SPD for Photovoltaic application	J29
6	Technical supplements	J32
	6.1 Lightning protection standards	J32
	6.2 The components of a SPD	J32
	6.3 End-of-life indication	J34
	6.4 Detailed characteristics of the external SCPD	J34
	6.5 Propagation of a lightning wave	J36
	6.6 Example of lightning current in TT system	J37

1 Overvoltage of atmospheric origin

1.1 Overvoltage definitions

Various types of overvoltage

An overvoltage is a voltage pulse or wave which is superimposed on the rated voltage of the network (see Fig. J1).

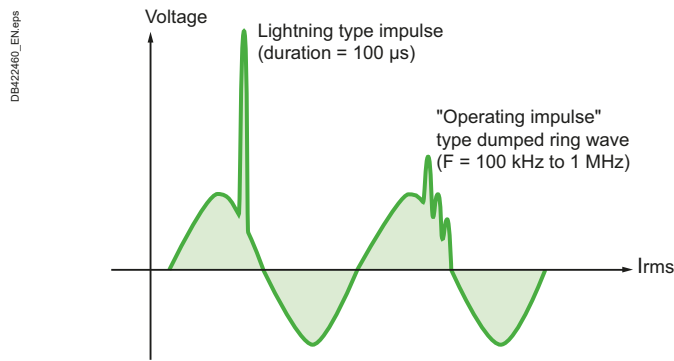


Fig. J1 Examples of overvoltage

This type of overvoltage is characterized by (see Fig. J2):

- the rise time t_f (in μs);
- the gradient S (in $kV/\mu s$).

An overvoltage disturbs equipment and produces electromagnetic radiation. Moreover, the duration of the overvoltage (T) causes an energy peak in the electric circuits which could destroy equipment.

J2

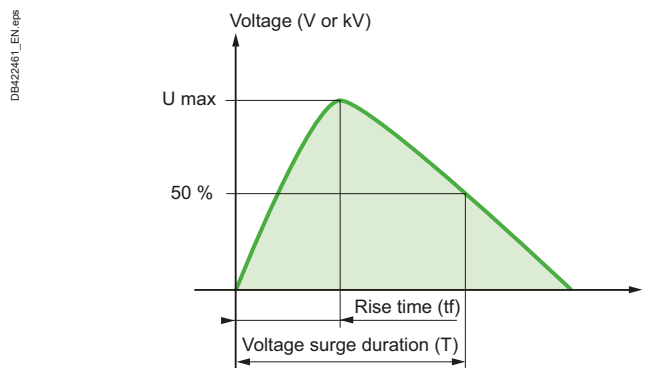


Fig. J2 Main characteristics of an overvoltage

Four types of overvoltage can disturb electrical installations and loads:

- **Switching surges:**
high-frequency overvoltages or burst disturbance (see Fig. J1) caused by a change in the steady state in an electrical network (during operation of switchgear).
- **Power-frequency overvoltages:**
overvoltages of the same frequency as the network (50, 60 or 400 Hz) caused by a permanent change of state in the network (following a fault: insulation fault, breakdown of neutral conductor, etc.).
- **Overvoltages caused by electrostatic discharge:**
very short overvoltages (a few nanoseconds) of very high frequency caused by the discharge of accumulated electric charges (for example, a person walking on a carpet with insulating soles is electrically charged with a voltage of several kilovolts).
- **Overvoltages of atmospheric origin.**

1 Overvoltage of atmospheric origin

Lightning strokes in a few figures:
Lightning flashes produce an extremely large quantity of pulsed electrical energy (see Fig. J4)

- of several thousand amperes (and several thousand volts),
- of high frequency (approximately 1 megahertz),
- of short duration (from a microsecond to a millisecond).

1.2 Overvoltage characteristics of atmospheric origin

Between 2000 and 5000 storms are constantly undergoing formation throughout the world. These storms are accompanied by lightning strokes which represent a serious hazard for persons and equipment. Lightning flashes hit the ground at an average of 30 to 100 strokes per second, i.e. 3 billion lightning strokes each year.

The table in Fig. J3 shows some lightning strike values with their related probability. As can be seen, 50% of lightning strokes have a current exceeding 35 kA and 5% a current exceeding 100 kA. The energy conveyed by the lightning stroke is therefore very high.

Cumulative probability (%)	Peak current (kA)
95	5
50	35
5	100
1	200

Fig. J3 Examples of lightning discharge values given by the IEC 62305-1 standard (2010 - Table A.3)

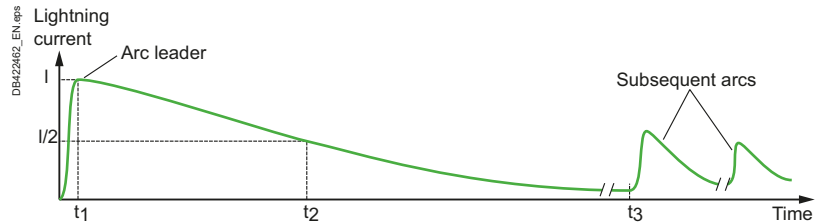


Fig. J4 Example of lightning current

Lightning also causes a large number of fires, mostly in agricultural areas (destroying houses or making them unfit for use). High-rise buildings are especially prone to lightning strokes.

1.3 Effects on electrical installations

Lightning damages electrical and electronic systems in particular: transformers, electricity meters and electrical appliances on both residential and industrial premises.

The cost of repairing the damage caused by lightning is very high. But it is very hard to assess the consequences of:

- disturbances caused to computers and telecommunication networks;
- faults generated in the running of programmable logic controller programs and control systems.

Moreover, the cost of operating losses may be far higher than the value of the equipment destroyed.

1 Overvoltage of atmospheric origin

Lightning is a high-frequency electrical phenomenon which causes overvoltages on all conductive items, especially on electrical cabling and equipment.

1.3.1 Lightning stroke impacts

Lightning strokes can affect the electrical (and/or electronic) systems of a building in two ways:

- by direct impact of the lightning stroke on the building (see Fig. J5a);
 - by indirect impact of the lightning stroke on the building:
 - A lightning stroke can fall on an overhead electric power line supplying a building (see Fig. J5b). The overcurrent and overvoltage can spread several kilometres from the point of impact.
 - A lightning stroke can fall near an electric power line (see Fig. J5c). It is the electromagnetic radiation of the lightning current that produces a high current and an overvoltage on the electric power supply network.
- In the latter two cases, the hazardous currents and voltages are transmitted by the power supply network.
- A lightning stroke can fall near a building (see Fig. J5d). The earth potential around the point of impact rises dangerously.

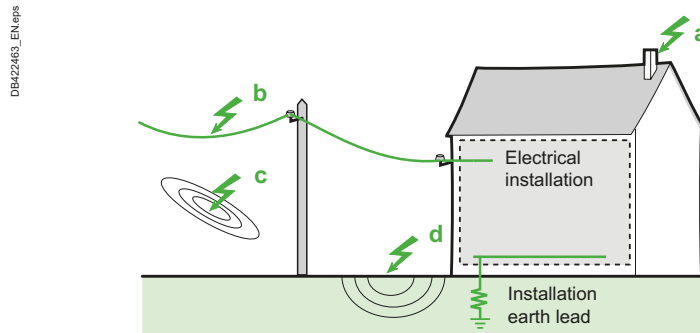


Fig. J5 Various types of lightning impact

In all cases, the consequences for electrical installations and loads can be dramatic.

Lightning falls on an unprotected building	Lightning falls near an overhead line.	Lightning falls near a building.
<p>The lightning current flows to earth via the more or less conductive structures of the building with very destructive effects:</p> <ul style="list-style-type: none"> ■ thermal effects: Very violent overheating of materials, causing fire, ■ mechanical effects: Structural deformation, ■ thermal flashover: Extremely dangerous phenomenon in the presence of flammable or explosive materials (hydrocarbons, dust, etc.) <p>The building and the installations inside the building are generally destroyed</p>	<p>The lightning current generates overvoltages through electromagnetic induction in the distribution system. These overvoltages are propagated along the line to the electrical equipment inside the buildings.</p> <p>The electrical installations inside the building are generally destroyed.</p>	<p>The lightning stroke generates the same types of overvoltage as those described opposite.</p> <p>In addition, the lightning current rises back from the earth to the electrical installation, thus causing equipment breakdown.</p>

Fig. J6 Consequence of a lightning stroke impact

1 Overvoltage of atmospheric origin

1.3.2 The various modes of propagation

■ Common mode

Common-mode overvoltages appear between live conductors and earth: phase-to-earth or neutral-to-earth (see Fig. J7). They are dangerous especially for appliances whose frame is connected to earth due to risks of dielectric breakdown.

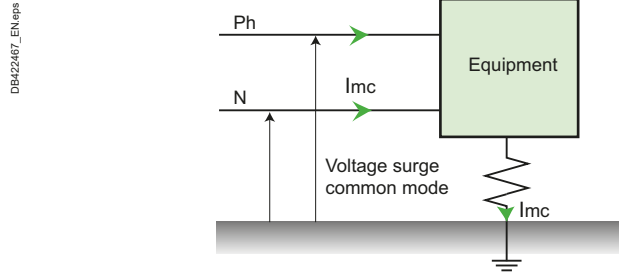


Fig. J7 Common mode

■ Differential mode

Differential-mode overvoltages appear between live conductors: phase-to-phase or phase-to-neutral (see Fig. J8). They are especially dangerous for electronic equipment, sensitive hardware such as computer systems, etc.

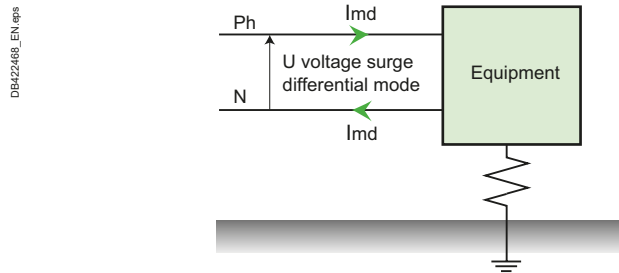


Fig. J8 Differential mode

1 Overvoltage of atmospheric origin

1.4 Characterization of the lightning wave

Analysis of the phenomena allows definition of the types of lightning current and voltage waves.

■ 2 types of current wave are considered by the IEC standards:

□ 10/350 μ s wave: to characterize the current waves from a direct lightning stroke (see Fig. J9);

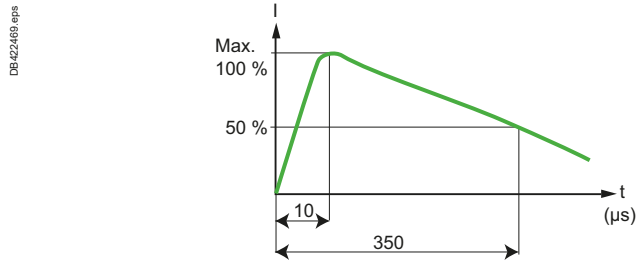


Fig. J9 10/350 μ s current wave

□ 8/20 μ s wave: to characterize the current waves from an indirect lightning stroke (see Fig. J10).

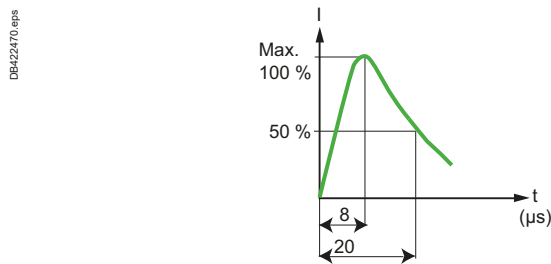


Fig. J10 8/20 μ s current wave

These two types of lightning current wave are used to define tests on SPDs (IEC standard 61643-11) and equipment immunity to lightning currents. The peak value of the current wave characterizes the intensity of the lightning stroke.

■ The overvoltages created by lightning strokes are characterized by a 1.2/50 μ s voltage wave (see Fig. J11).

This type of voltage wave is used to verify equipment's withstand to overvoltages of atmospheric origin (impulse voltage as per IEC 61000-4-5).

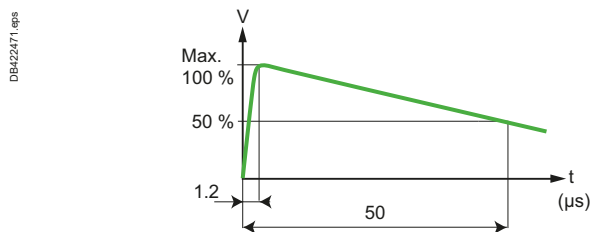


Fig. J11 1.2/50 μ s voltage wave

2 Principle of lightning protection

The system for protecting a building against the effects of lightning must include:

- protection of structures against direct lightning strokes;
- protection of electrical installations against direct and indirect lightning strokes.

2.1 General rules

Procedure to prevent risks of lightning strike

The basic principle for protection of an installation against the risk of lightning strikes is to prevent the disturbing energy from reaching sensitive equipment. To achieve this, it is necessary to:

- capture the lightning current and channel it to earth via the most direct path (avoiding the vicinity of sensitive equipment);
- perform equipotential bonding of the installation; This equipotential bonding is implemented by bonding conductors, supplemented by Surge Protection Devices (SPDs) or spark gaps (e.g., antenna mast spark gap).
- minimize induced and indirect effects by installing SPDs and/or filters.

Two protection systems are used to eliminate or limit overvoltages: they are known as the building protection system (for the outside of buildings) and the electrical installation protection system (for the inside of buildings).

2.2 Building protection system

The role of the building protection system is to protect it against direct lightning strokes.

The system consists of:

- the capture device: the lightning protection system;
- down-conductors designed to convey the lightning current to earth;
- «crow's foot» earth leads connected together;
- links between all metallic frames (equipotential bonding) and the earth leads.

When the lightning current flows in a conductor, if potential differences appear between it and the frames connected to earth that are located in the vicinity, the latter can cause destructive flashovers.

2.2.1 The 3 types of lightning protection system

Three types of building protection are used:

- **The lightning rod (simple rod or with triggering system)**

The lightning rod is a metallic capture tip placed at the top of the building. It is earthed by one or more conductors (often copper strips) (see Fig. J12).

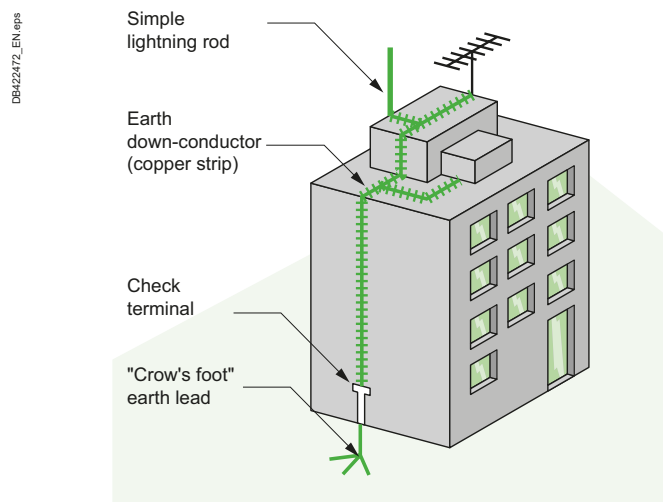


Fig. J12 Lightning rod (simple rod or with triggering system)

2 Principle of lightning protection

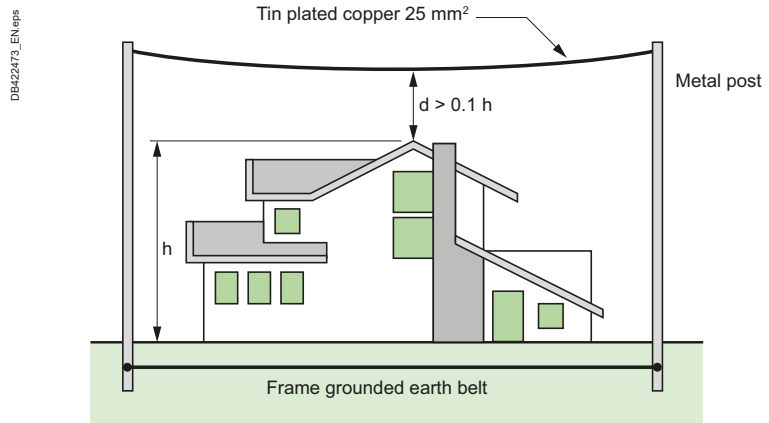


Fig. J13 Taut wires

DB422474.eps

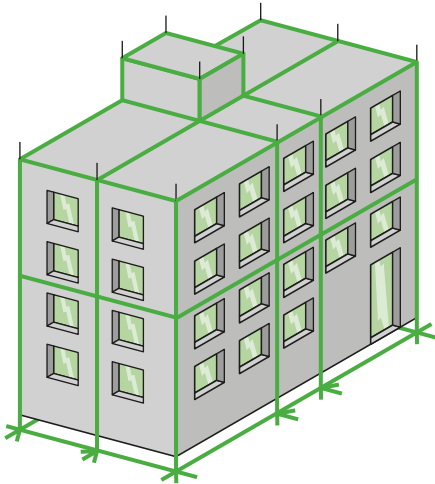


Fig. J14 Meshed cage (Faraday cage)

■ The lightning rod with taut wires

These wires are stretched above the structure to be protected. They are used to protect special structures: rocket launching areas, military applications and protection of high-voltage overhead lines (see Fig. J13).

■ The lightning conductor with meshed cage (Faraday cage)

This protection involves placing numerous down conductors/tapes symmetrically all around the building. (see Fig. J14).

This type of lightning protection system is used for highly exposed buildings housing very sensitive installations such as computer rooms.

J8

2.2.2 Consequences of building protection for the electrical installation's equipment

50% of the lightning current discharged by the building protection system rises back into the earthing networks of the electrical installation (see Fig. J15): the potential rise of the frames very frequently exceeds the insulation withstand capability of the conductors in the various networks (LV, telecommunications, video cable, etc.). Moreover, the flow of current through the down-conductors generates induced overvoltages in the electrical installation.

As a consequence, the building protection system does not protect the electrical installation: it is therefore compulsory to provide for an electrical installation protection system.

DB422475_EN.eps

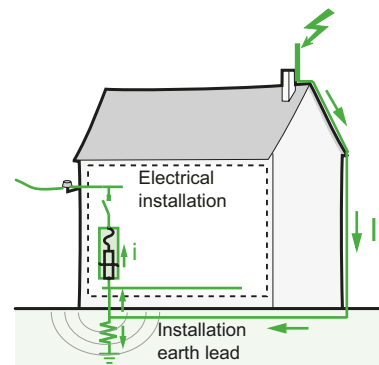


Fig. J15 Direct lightning back current

2 Principle of lightning protection

2.3 Electrical installation protection system

The main objective of the electrical installation protection system is to limit overvoltages to values that are acceptable for the equipment.

The electrical installation protection system consists of:

- one or more SPDs depending on the building configuration;
- the equipotential bonding: metallic mesh of exposed conductive parts.

2.3.1 Implementation

The procedure to protect the electrical and electronic systems of a building is as follows.

Search for information

- Identify all sensitive loads and their location in the building.
- Identify the electrical and electronic systems and their respective points of entry into the building.
- Check whether a lightning protection system is present on the building or in the vicinity.
- Become acquainted with the regulations applicable to the building's location.
- Assess the risk of lightning strike according to the geographic location, type of power supply, lightning strike density, etc.

Solution implementation

- Install bonding conductors on frames by a mesh.
- Install a SPD in the LV incoming switchboard.
- Install an additional SPD in each subdistribution board located in the vicinity of sensitive equipment (see Fig. J16).

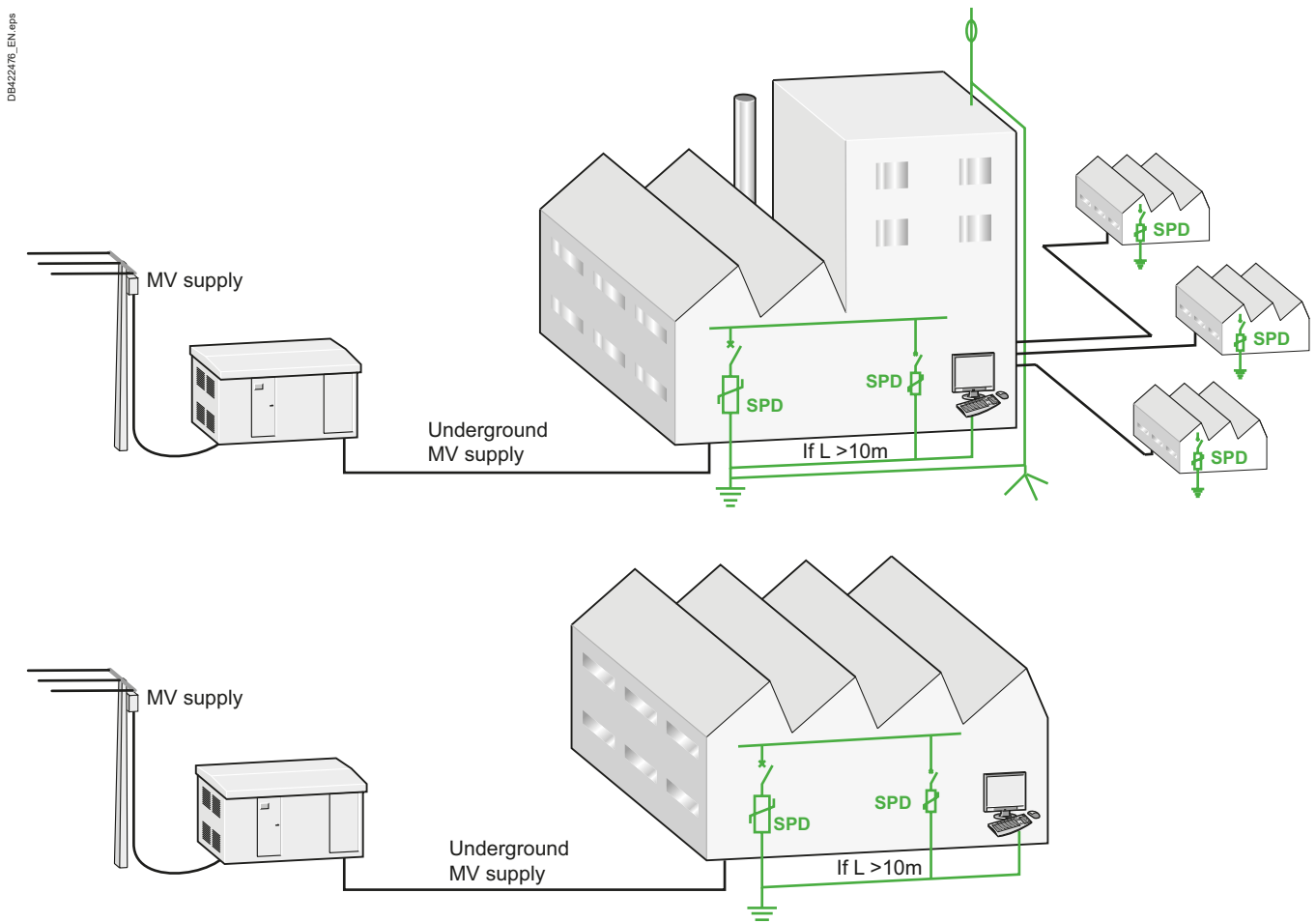


Fig. J16 Example of protection of a large-scale electrical installation

2 Principle of lightning protection

Surge Protection Devices (SPD) are used for electric power supply networks, telephone networks, and communication and automatic control buses.

SPD connected in parallel has a high impedance. Once the transient overvoltage appears in the system, the impedance of the device decreases so surge current is driven through the SPD, bypassing the sensitive equipment.

2.4 The Surge Protection Device (SPD)

The Surge Protection Device (SPD) is a component of the electrical installation protection system.

This device is connected in parallel on the power supply circuit of the loads that it has to protect (see Fig. J17). It can also be used at all levels of the power supply network.

This is the most commonly used and most efficient type of overvoltage protection.

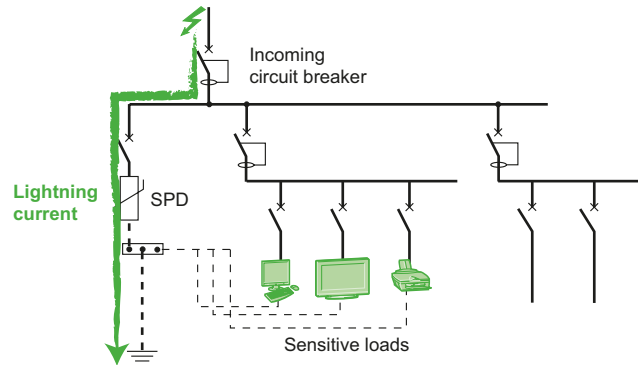


Fig. J17 Principle of protection system in parallel

Principle

SPD is designed to limit transient overvoltages of atmospheric origin and divert current waves to earth, so as to limit the amplitude of this overvoltage to a value that is not hazardous for the electrical installation and electric switchgear and controlgear.

SPD eliminates overvoltages:

- in common mode, between phase and neutral or earth;
- in differential mode, between phase and neutral.

In the event of an overvoltage exceeding the operating threshold, the SPD

- conducts the energy to earth, in common mode;
- distributes the energy to the other live conductors, in differential mode.

The three types of SPD:

■ Type 1 SPD

The Type 1 SPD is recommended in the specific case of service-sector and industrial buildings, protected by a lightning protection system or a meshed cage. It protects electrical installations against direct lightning strokes. It can discharge the back-current from lightning spreading from the earth conductor to the network conductors.

Type 1 SPD is characterized by a 10/350 μ s current wave.

■ Type 2 SPD

The Type 2 SPD is the main protection system for all low voltage electrical installations. Installed in each electrical switchboard, it prevents the spread of overvoltages in the electrical installations and protects the loads.

Type 2 SPD is characterized by an 8/20 μ s current wave.

■ Type 3 SPD

These SPDs have a low discharge capacity. They must therefore mandatorily be installed as a supplement to Type 2 SPD and in the vicinity of sensitive loads.

Type 3 SPD is characterized by a combination of voltage waves (1.2/50 μ s) and current waves (8/20 μ s).

2 Principle of lightning protection

■ SPD normative definition

IEC 61643-1	Direct lightning stroke		Indirect lightning stroke
	Class I test		Class II test
IEC 61643-11/2011	Type 1: T1	Type 2: T2	Type 3: T3
EN/IEC 61643-11	Type 1	Type 2	Type 3
Former VDE 0675v	B	C	D
Type of test wave	10/350	8/20	1.2/50 + 8/20

Note 1: There exist **T1** + **T2** SPD (or Type 1 + 2 SPD) combining protection of loads against direct and indirect lightning strokes.

Note 2: some **T2** SPD can also be declared as **T3**.

Fig. J18 SPD standard definition

2.4.1 Characteristics of SPD

International standard IEC 61643-11 Edition 1.0 (03/2011) defines the characteristics and tests for SPD connected to low voltage distribution systems (see Fig. J19).

■ Common characteristics

- **U_c:** Maximum continuous operating voltage
This is the A.C. or D.C. voltage above which the SPD becomes active. This value is chosen according to the rated voltage and the system earthing arrangement.
- **U_p:** Voltage protection level (at I_n)
This is the maximum voltage across the terminals of the SPD when it is active. This voltage is reached when the current flowing in the SPD is equal to I_n. The voltage protection level chosen must be below the overvoltage withstand capability of the loads (see section 3.2). In the event of lightning strokes, the voltage across the terminals of the SPD generally remains less than U_p.
- **I_n:** Nominal discharge current
This is the peak value of a current of 8/20 μs waveform that the SPD is capable of discharging minimum 19 times [1].

Why is I_n important?

I_n corresponds to a nominal discharge current that a SPD can withstand at least 19 times [1]: a higher value of I_n means a longer life for the SPD, so it is strongly recommended to choose higher values than the minimum imposed value of 5 kA.

Why is I_{imp} important?

IEC 62305 standard requires a maximum impulse current value of 25 kA per pole for three-phase system. This means that for a 3P+N network the SPD should be able to withstand a total maximum impulse current of 100kA coming from the earth bonding.

Why is I_{max} important?

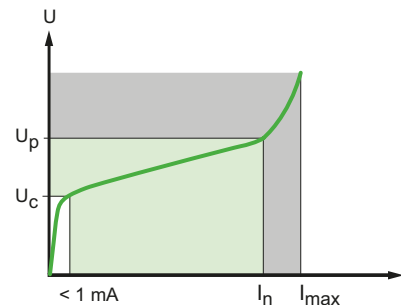
If you compare 2 SPDs with the same I_n, but with different I_{max}: the SPD with higher I_{max} value has a higher «safety margin» and can withstand higher surge current without being damaged.

[1] Test sequence according to standard IEC 61643-11 for SPD based on MOV (varistor). A total of 19 impulses at I_n:

- One positive impulse
- One negative impulse
- 15 impulses synchronised at every 30° on the 50 Hz voltage
- One positive impulse
- One negative impulse

[2] for type 1 SPD, after the 15 impulses at I_n (see previous note):

- One impulse at 0.1 x I_{imp}
- One impulse at 0.25 x I_{imp}
- One impulse at 0.5 x I_{imp}
- One impulse at 0.75 x I_{imp}
- One impulse at I_{imp}



In green, the guaranteed operating range of the SPD.

Fig. J19 Time/current characteristic of a SPD with varistor

■ Type 1 SPD

- **I_{imp}:** Impulse current
This is the peak value of a current of 10/350 μs waveform that the SPD is capable of discharging at least one time [2].
- **I_{fi}:** Autoextinguish follow current
Applicable only to the spark gap technology.

This is the current (50 Hz) that the SPD is capable of interrupting by itself after flashover. This current must always be greater than the prospective short-circuit current at the point of installation.

■ Type 2 SPD

- **I_{max}:** Maximum discharge current
This is the peak value of a current of 8/20 μs waveform that the SPD is capable of discharging once.

■ Type 3 SPD

- **U_{oc}:** Open-circuit voltage applied during class III (Type 3) tests.

2 Principle of lightning protection

2.4.2 Main applications

■ Low Voltage SPD

Very different devices, from both a technological and usage viewpoint, are designated by this term. Low voltage SPDs are modular to be easily installed inside LV switchboards.

There are also SPDs adaptable to power sockets, but these devices have a low discharge capacity.

■ SPD for communication networks

These devices protect telephon networks, switched networks and automatic control networks (bus) against overvoltages coming from outside (lightning) and those internal to the power supply network (polluting equipment, switchgear operation, etc.).

Such SPDs are also installed in RJ11, RJ45, ... connectors or integrated into loads.

3 Design of the electrical installation protection system

To protect an electrical installation in a building, simple rules apply for the choice of

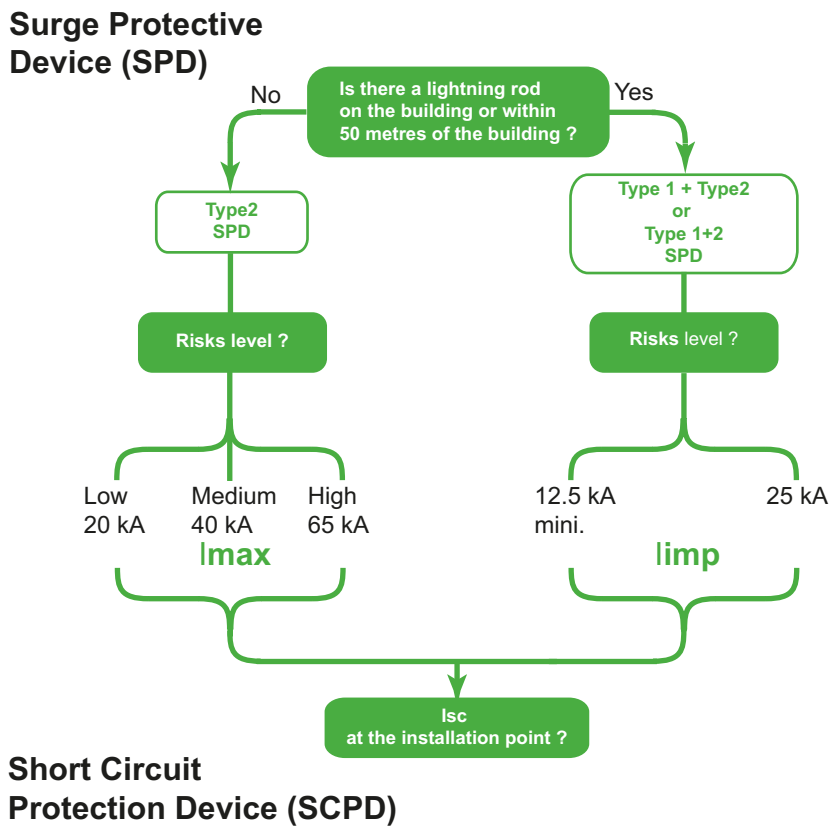
- SPD(s);
- its protection system.

3.1 Design rules

For a power distribution system, the main characteristics used to define the lightning protection system and select a SPD to protect an electrical installation in a building are:

- SPD
- quantity of SPD;
- type;
- level of exposure to define the SPD's maximum discharge current I_{max} .
- Short circuit protection device
- maximum discharge current I_{max} ;
- short-circuit current I_{sc} at the point of installation.

The logic diagram in the Fig. J20 below illustrates this design rule.



J13

Fig. J20 Logic diagram for selection of a protection system

The other characteristics for selection of a SPD are predefined for an electrical installation.

- number of poles in SPD;
- voltage protection level U_p ;
- operating voltage U_c .

This sub-section J3 describes in greater detail the criteria for selection of the protection system according to the characteristics of the installation, the equipment to be protected and the environment.

3 Design of the electrical installation protection system

A SPD must always be installed at the origin of the electrical installation.

3.2 Elements of the protection system

3.2.1 Location and type of SPD

The type of SPD to be installed at the origin of the installation depends on whether or not a lightning protection system is present. If the building is fitted with a lightning protection system (as per IEC 62305), a Type 1 SPD should be installed.

For SPD installed at the incoming end of the installation, the IEC 60364 installation standards lay down minimum values for the following 2 characteristics:

- Nominal discharge current **$I_n = 5 \text{ kA (8/20) } \mu\text{s}$** ;
- Voltage protection level **$U_p \text{ (at } I_n) < 2.5 \text{ kV}$** .

The number of additional SPDs to be installed is determined by:

- the size of the site and the difficulty of installing bonding conductors. On large sites, it is essential to install a SPD at the incoming end of each subdistribution enclosure.
- the distance separating sensitive loads to be protected from the incoming-end protection device. When the loads are located more than 10 meters away from the incoming-end protection device, it is necessary to provide for additional fine protection as close as possible to sensitive loads. The phenomena of wave reflection is increasing from 10 meters (see chapter 6.5)
- the risk of exposure. In the case of a very exposed site, the incoming-end SPD cannot ensure both a high flow of lightning current and a sufficiently low voltage protection level. In particular, a Type 1 SPD is generally accompanied by a Type 2 SPD.

The table in Fig. J21 below shows the quantity and type of SPD to be set up on the basis of the two factors defined above.

J14

DB422480_EN.eps

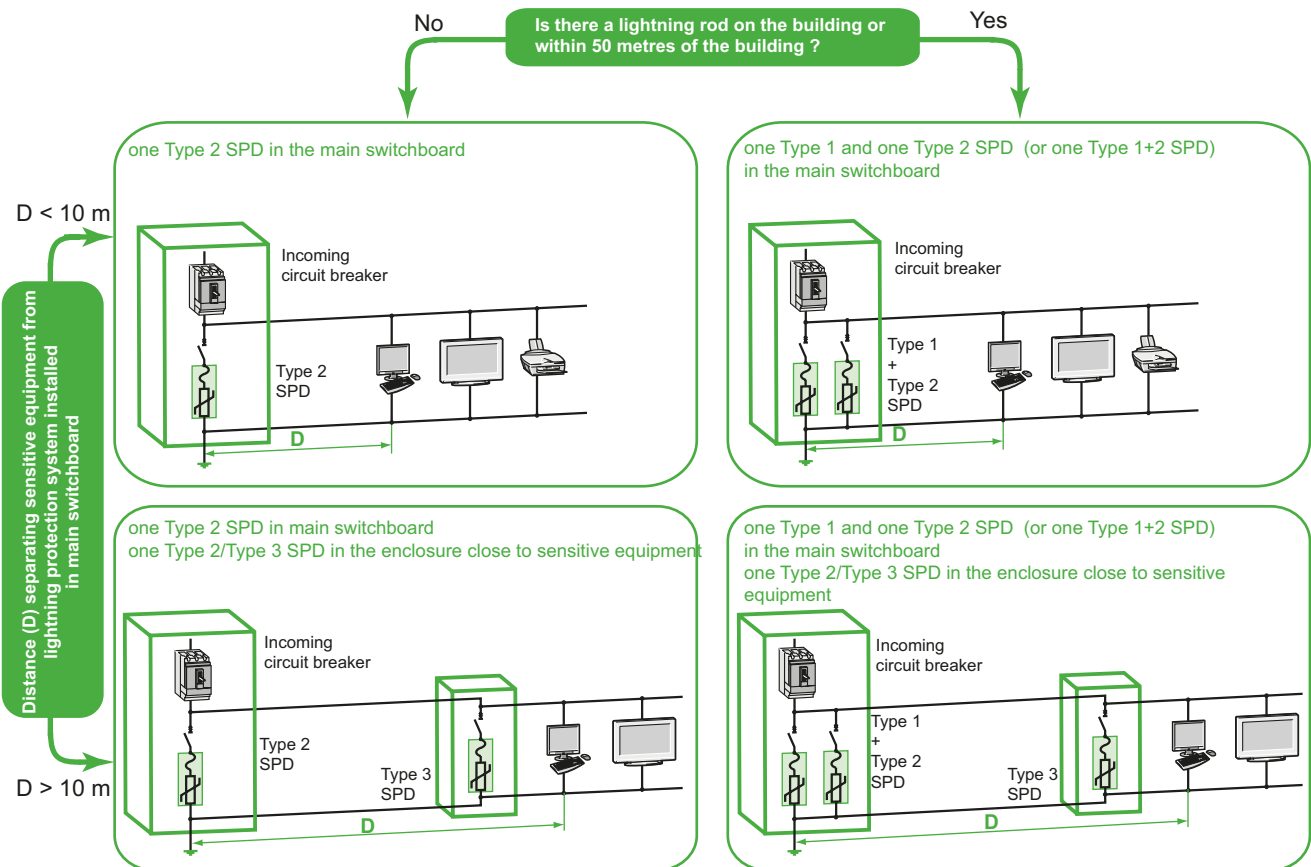


Fig. J21 The 4 cases of SPD implementation

Note : The Type 1 SPD is installed in the electrical switchboard connected to the earth lead of the lightning protection system.

3 Design of the electrical installation protection system

3.2.2 Protection distributed levels

Several protection levels of SPD allows the energy to be distributed among several SPDs, as shown in Fig. J22 in which the three types of SPD are provided for:

- Type 1: when the building is fitted with a lightning protection system and located at the incoming end of the installation, it absorbs a very large quantity of energy;
- Type 2: absorbs residual overvoltages;
- Type 3: provides «fine» protection if necessary for the most sensitive equipment located very close to the loads.

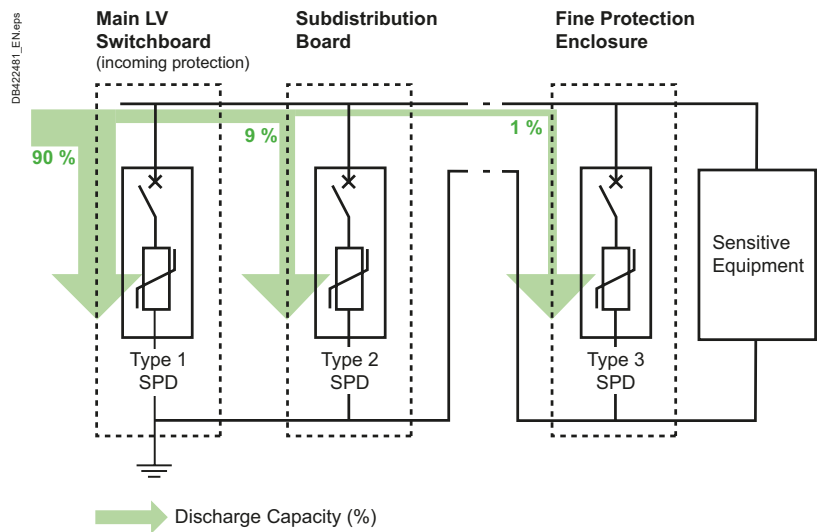


Fig. J22 Fine protection architecture
 Note: The Type 1 and 2 SPD can be combined in a single SPD

3 Design of the electrical installation protection system

3.3 Common characteristics of SPDs according to the installation characteristics

3.3.1 Operating voltage U_c

Depending on the system earthing arrangement, the maximum continuous operating voltage U_c of SPD must be equal to or greater than the values shown in the table in Fig. J23.

SPDs connected between (as applicable)	System configuration of distribution network		
	TN system	TT system	IT system
Line conductor and neutral conductor	$1.1 U / \sqrt{3}$	$1.1 U / \sqrt{3}$	$1.1 U / \sqrt{3}$
Line conductor and PE conductor	$1.1 U / \sqrt{3}$	$1.1 U / \sqrt{3}$	$1.1 U$
Line conductor and PEN conductor	$1.1 U / \sqrt{3}$	N/A	N/A
Neutral conductor and PE conductor	$U / \sqrt{3}^{[a]}$	$U / \sqrt{3}^{[a]}$	$1.1 U / \sqrt{3}$

[a] these values are related to worst-case fault conditions, therefore the tolerance of 10 % is not taken into account.

N/A: not applicable

U: line-to-line voltage of the low-voltage system

Fig. J23 Stipulated minimum value of U_c for SPDs depending on the system earthing arrangement (based on Table 534.2 of the IEC 60364-5-53 standard)

The most common values of U_c chosen according to the system earthing arrangement.

TT, TN: 260, 320, 340, 350 V

IT: 440, 460 V

3.3.2 Voltage protection level U_p (at I_n)

The IEC 60364-4-44 standard helps with the choice of the protection level U_p for the SPD in function of the loads to be protected. The table of Fig. J24 indicates the impulse withstand capability of each kind of equipment.

Nominal voltage of the installation ^[a] (V)	Voltage line to neutral derived from nominal voltages a.c. or d.c. up to and including (V)	Required rated impulse withstand voltage of equipment ^[c] (kV)			
		Overvoltage category IV (equipment with very high rated impulse voltage)	Overvoltage category III (equipment with high rated impulse voltage)	Overvoltage category II (equipment with normal rated impulse voltage)	Overvoltage category I (equipment with reduced rated impulse voltage)
120/208	150	4	2.5	1.5	0.8
230/400 ^{[b],[d]}	300	6	4	2.5	1.5
277/480 ^[b]					
400/690	600	8	6	4	2.5
1000	1 000	12	8	6	4
1500 d.c.	1 500 d.c.			8	6

[a] According to IEC 60038:2009.

[b] In Canada and USA, for voltages to earth higher than 300 V, the rated impulse voltage corresponding to the next highest voltage in this column applies.

[c] This rated impulse voltage is applied between live conductors and PE.

[d] For IT systems operations at 220-240 V, the 230/400 row shall be used, due to the voltage to earth at the earth fault on one line.

Fig. J24 Required rated impulse voltage of equipment U_w (table 443.2 of IEC 60364-4-44)

3 Design of the electrical installation protection system

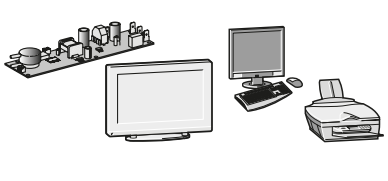

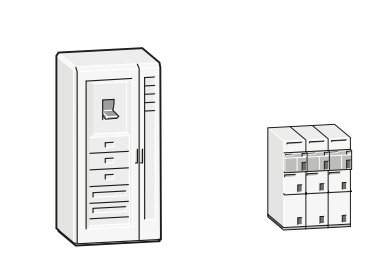
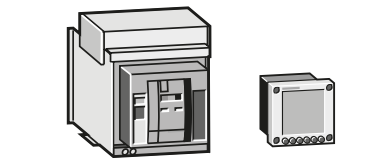
	<p>■ Equipment of overvoltage category I is only suitable for use in the fixed installation of buildings where protective means are applied outside the equipment – to limit transient overvoltages to the specified level. Examples of such equipment are those containing electronic circuits like computers, appliances with electronic programmes, etc.</p>
	<p>■ Equipment of overvoltage category II is suitable for connection to the fixed electrical installation, providing a normal degree of availability normally required for current-using equipment. Examples of such equipment are household appliances and similar loads.</p>
	<p>■ Equipment of overvoltage category III is for use in the fixed installation downstream of, and including the main distribution board, providing a high degree of availability. Examples of such equipment are distribution boards, circuit-breakers, wiring systems including cables, bus-bars, junction boxes, switches, socket-outlets) in the fixed installation, and equipment for industrial use and some other equipment, e.g. stationary motors with permanent connection to the fixed installation.</p>
	<p>■ Equipment of overvoltage category IV is suitable for use at, or in the proximity of, the origin of the installation, for example upstream of the main distribution board. Examples of such equipment are electricity meters, primary overcurrent protection devices and ripple control units.</p>

Fig. J25 Overvoltage category of equipment

The «installed» Up performance should be compared with the impulse withstand capability of the loads.

SPD has a voltage protection level Up that is intrinsic, i.e. defined and tested independently of its installation. In practice, for the choice of Up performance of a SPD, a safety margin must be taken to allow for the overvoltages inherent in the installation of the SPD (see Fig. J26 and §4.1).

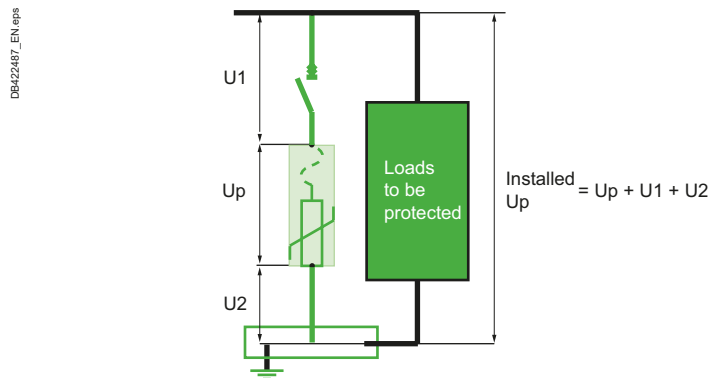


Fig. J26 “Installed” Up

The «installed» voltage protection level Up generally adopted to protect sensitive equipment in 230/400 V electrical installations is 2.5 kV (overvoltage category II, see Fig. J27).

Note:
If the stipulated voltage protection level cannot be achieved by the incoming-end SPD or if sensitive equipment items are remote (see section 3.2.1), additional coordinated SPD must be installed to achieve the required protection level.

3 Design of the electrical installation protection system

3.3.3 Number of poles

■ Depending on the system earthing arrangement, it is necessary to provide for a SPD architecture ensuring protection in common mode (CM) and differential mode (DM).

	TT	TN-C	TN-S	IT
Phase-to-neutral (DM)	Recommended [1]	-	Recommended	Not useful
Phase-to-earth (PE or PEN) (CM)	Yes	Yes	Yes	Yes
Neutral-to-earth (PE) (CM)	Yes	-	Yes	Yes[2]

[1] The protection between phase and neutral can either be incorporated in the SPD placed at the origin of the installation, or be removed close to the equipment to be protected

[2] If neutral distributed

Fig. J27 Protection need according to the system earthing arrangement

Note:

■ **Common-mode overvoltage**

A basic form of protection is to install a SPD in common mode between phases and the PE (or PEN) conductor, whatever the type of system earthing arrangement used.

■ **Differential-mode overvoltage**

In the TT and TN-S systems, earthing of the neutral results in an asymmetry due to earth impedances which leads to the appearance of differential-mode voltages, even though the overvoltage induced by a lightning stroke is common-mode.

2P, 3P and 4P SPDs (see Fig. J28)

- These are adapted to the IT, TN-C, TN-C-S systems.
- They provide protection merely against common-mode overvoltages.

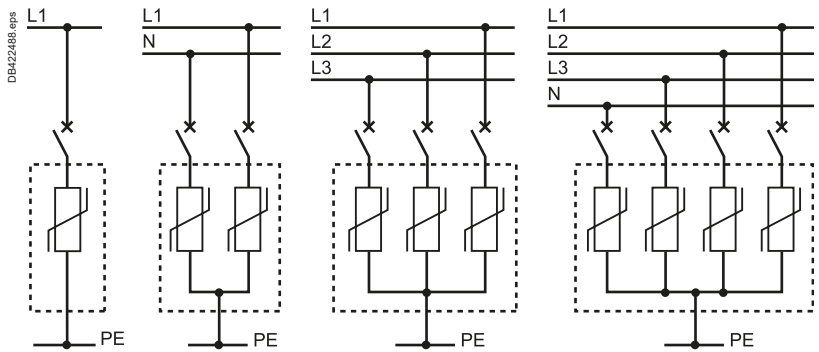


Fig. J28 1P, 2P, 3P, 4P SPDs

1P + N, 3P + N SPDs (see Fig. J29)

- These are adapted to the TT and TN-S systems.
- They provide protection against common-mode and differential-mode overvoltages.

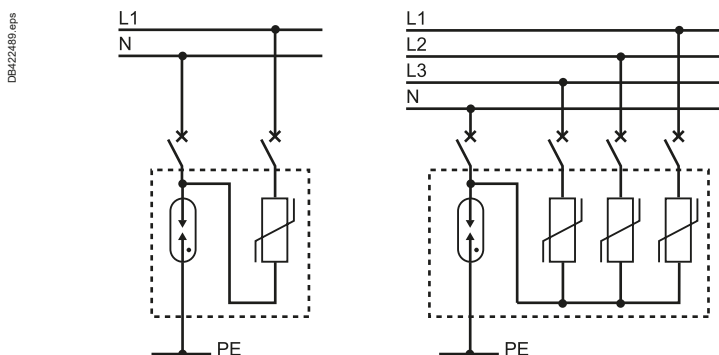


Fig. J29 1P + N, 3P + N SPDs

J18

3 Design of the electrical installation protection system

DE42490_EN.eps

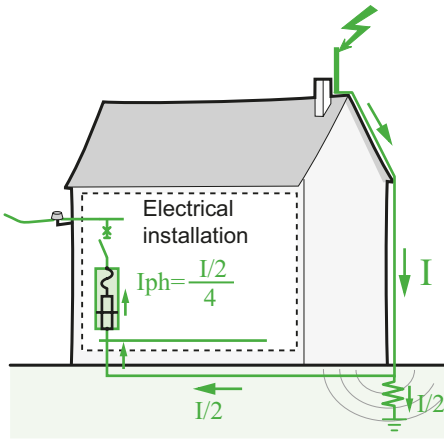


Fig. J30 Basic example of balanced limp current distribution in 3 phase system

3.4 Selection of a Type 1 SPD

3.4.1 Impulse current limp

- Where there are no national regulations or specific regulations for the type of building to be protected: the impulse current limp shall be at least 12.5 kA (10/350 μs wave) per branch in accordance with IEC 60364-5-534.
- Where regulations exist: standard IEC 62305-2 defines 4 levels: I, II, III and IV. The table in **Fig. J31** shows the different levels of limp in the regulatory case.

Protection level as per EN 62305-2	External lightning protection system designed to handle direct flash of:	Minimum required limp for Type 1 SPD for line-neutral network
I	200 kA	25 kA/pole
II	150 kA	18.75 kA/pole
III / IV	100 kA	12.5 kA/pole

Fig. J31 Table of limp values according to the building's voltage protection level (based on IEC/EN 62305-2)

3.4.2 Autoextinguish follow current I_{fi}

This characteristic is applicable only for SPDs with spark gap technology. The autoextinguish follow current I_{fi} must always be greater than the prospective short-circuit current I_{sc} at the point of installation.

3.5 Selection of a Type 2 SPD

3.5.1 Maximum discharge current I_{max}

The maximum discharge current I_{max} is defined according to the estimated exposure level relative to the building's location.

The value of the maximum discharge current (I_{max}) is determined by a risk analysis (see table in **Fig. J32**).

	Exposure level		
	Low	Medium	High
Building environment	Building located in an urban or suburban area of grouped housing	Building located in a plain	Building where there is a specific risk: pylon, tree, mountainous region, wet area or pond, etc.
Recommended I _{max} value (kA)	20	40	65

Fig. J32 Recommended maximum discharge current I_{max} according to the exposure level

3 Design of the electrical installation protection system

The protection devices (thermal and short circuit) must be coordinated with the SPD to ensure reliable operation, i.e.

- ensure continuity of service:
 - withstand lightning current waves;
 - not generate excessive residual voltage.
- ensure effective protection against all types of overcurrent:
 - overload following thermal runaway of the varistor;
 - short circuit of low intensity (impedant);
 - short circuit of high intensity.

3.6 Selection of external Short Circuit Protection Device (SCPD)

3.6.1 Risks to be avoided at end of life of the SPDs

■ Due to ageing

In the case of natural end of life due to ageing, protection is of the thermal type. SPD with varistors must have an internal disconnecter which disables the SPD.

Note: End of life through thermal runaway does not concern SPD with gas discharge tube or encapsulated spark gap.

■ Due to a fault

The causes of end of life due to a short-circuit fault are:

- Maximum discharge capacity exceeded. This fault results in a strong short circuit.
- A fault due to the distribution system (neutral/phase switchover, neutral disconnection).
- Gradual deterioration of the varistor.

The latter two faults result in an impedant short circuit.

The installation must be protected from damage resulting from these types of fault: the internal (thermal) disconnecter defined above does not have time to warm up, hence to operate.

A special device called «external Short Circuit Protection Device (external SCPD)», capable of eliminating the short circuit, should be installed. It can be implemented by a circuit breaker or fuse device.

3.6.2 Characteristics of the external SCPD

The external SCPD should be coordinated with the SPD. It is designed to meet the following two constraints:

Lightning current withstand

The lightning current withstand is an essential characteristic of the SPD's external Short Circuit Protection Device.

The external SCPD must not trip upon 15 successive impulse currents at I_n .

Short-circuit current withstand

■ **The breaking capacity** is determined by the installation rules (IEC 60364 standard):

The external SCPD should have a breaking capacity equal to or greater than the prospective short-circuit current I_{sc} at the installation point (in accordance with the IEC 60364 standard).

■ Protection of the installation against short circuits

In particular, the impedant short circuit dissipates a lot of energy and should be eliminated very quickly to prevent damage to the installation and to the SPD.

The right association between a SPD and its external SCPD must be given by the manufacturer.

3 Design of the electrical installation protection system

3.6.3 Installation mode for the external SCPD

■ **Device «in series»**

The SCPD is described as «in series» (see Fig. J33) when the protection is performed by the general protection device of the network to be protected (for example, connection circuit breaker upstream of an installation).

■ **Device «in parallel»**

The SCPD is described as «in parallel» (see Fig. J34) when the protection is performed specifically by a protection device associated with the SPD.

DB422481.eps

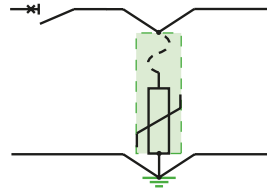


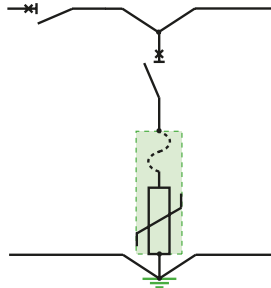
Fig. J33 SCPD "in series"

- The external SCPD is called a «disconnecting circuit breaker» if the function is performed by a circuit breaker.
- The disconnecting circuit breaker may or may not be integrated into the SPD.

Note:

In the case of a SPD with gas discharge tube or encapsulated spark gap, the SCPD allows the current to be cut immediately after use.

DB422482.eps



DB422483.eps

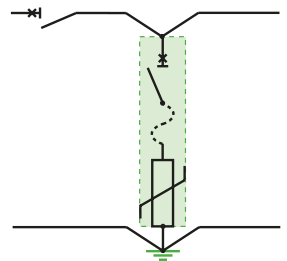


Fig. J34 SCPD "in parallel"

3 Design of the electrical installation protection system

3.6.4 Guarantee of protection

The external SCPD should be coordinated with the SPD, and tested and guaranteed by the SPD manufacturer in accordance with the recommendations of the IEC 61643-11 standard. It should also be installed in accordance with the manufacturer's recommendations. As an example, see the Schneider Electric SCPD+SPD coordination tables.

When this device is integrated, conformity with product standard IEC 61643-11 naturally ensures protection.



Fig. J35 SPDs with external SCPD, non-integrated (iC60N + iPRD 40r) and integrated (iQuick PRD 40r)

3.6.5 Summary of external SCPDs characteristics

A detailed analysis of the characteristics is given in section 6.4.

The table in Fig. J36 shows, on an example, a summary of the characteristics according to the various types of external SCPD.

J22

Installation mode for the external SCPD	In series	In parallel		
Surge protection of equipment				
Protection of installation at end of life	=	=	=	=
Continuity of service at end of life	-	=	+	++
Maintenance at end of life	--	=	+	+
	No guarantee of protection possible	Manufacturer's guarantee Protection from impedant short circuits not well ensured	Protection from short circuits perfectly ensured	Full guarantee
	Shutdown of the installation required	Change of fuses	Immediate resetting	

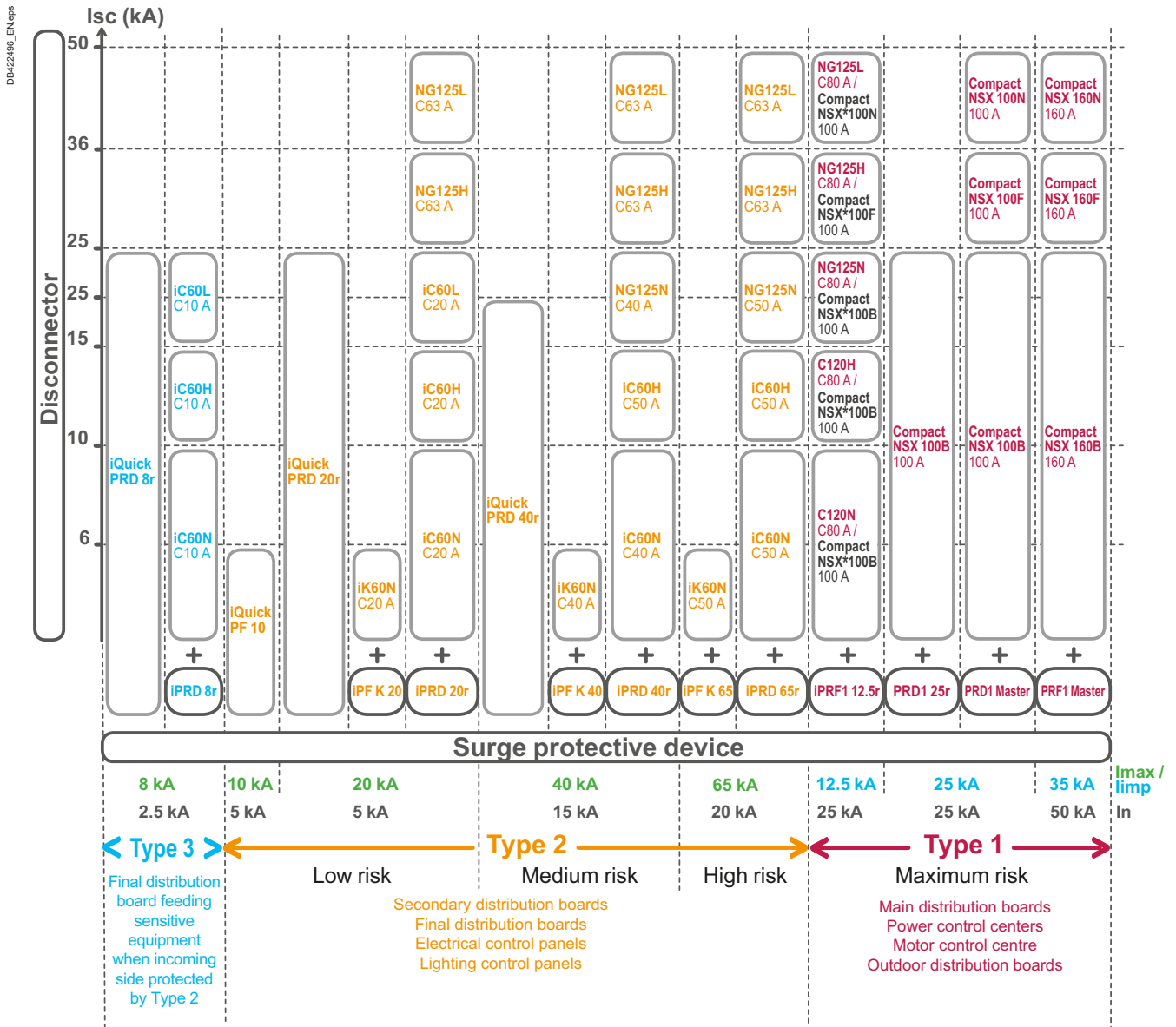
Fig. J36 Characteristics of end-of-life protection of a Type 2 SPD according to the external SCPDs

3.7 SPD and protection device coordination table

The table in Fig. J37 below shows the coordination of disconnecting circuit breakers (external SCPD) for Type 1 and 2 SPDs of the Schneider Electric brand for all levels of short-circuit currents.

Coordination between SPD and its disconnecting circuit breakers, indicated and guaranteed by Schneider Electric, ensures reliable protection (lightning wave withstand, reinforced protection of impedant short-circuit currents, etc.)

3 Design of the electrical installation protection system



J23

All circuit breakers are C curve
 (*) Compact NSX in this case is for lightning impulse current withstand.

Fig. J37 Example of coordination table between SPDs and their disconnecting circuit breakers (Schneider Electric brand). Always refer to the latest tables provided by manufacturers.

3.7.1 Coordination with upstream protection devices

Coordination with overcurrent protection devices

In an electrical installation, the external SCPD is an apparatus identical to the protection apparatus: this makes it possible to apply **selectivity and cascading** techniques for technical and economic optimization of the protection plan.

Coordination with residual current devices

If the SPD is installed downstream of an earth leakage protection device, the latter should be of the «si» or selective type with an immunity to pulse currents of at least 3 kA (8/20 μs current wave).

4 Installation of SPDs

Connections of a SPD to the loads should be as short as possible in order to reduce the value of the voltage protection level (installed U_p) on the terminals of the protected equipment.
The total length of SPD connections to the network and the earth terminal block should not exceed 50 cm.

4.1 Connection

One of the essential characteristics for the protection of equipment is the maximum voltage protection level (installed U_p) that the equipment can withstand at its terminals. Accordingly, a SPD should be chosen with a voltage protection level U_p adapted to protection of the equipment (see Fig. J38). The total length of the connection conductors is

$$L = L1 + L2 + L3.$$

For high-frequency currents, the impedance per unit length of this connection is approximately $1 \mu\Omega/m$.

Hence, applying Lenz's law to this connection: $\Delta U = L di/dt$

The normalized $8/20 \mu s$ current wave, with a current amplitude of 8 kA, accordingly creates a voltage rise of 1000 V per metre of cable.

$$\Delta U = 1 \times 10^{-6} \times 8 \times 10^3 / 8 \times 10^{-6} = 1000 \text{ V}$$

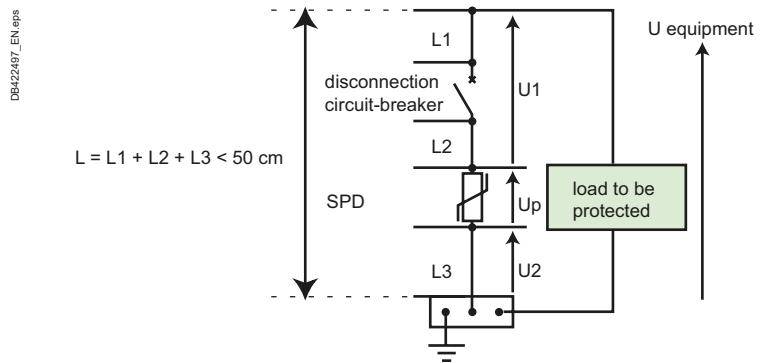


Fig. J38 Connections of a SPD $L < 50 \text{ cm}$

As a result the voltage across the equipment terminals, installed U_p , is:

$$\text{installed } U_p = U_p + U1 + U2$$

If $L1 + L2 + L3 = 50 \text{ cm}$, and the wave is $8/20 \mu s$ with an amplitude of 8 kA , the voltage across the equipment terminals will be $U_p + 500 \text{ V}$.

4.1.1 Connection in plastic enclosure

Fig. J39 below shows how to connect a SPD in plastic enclosure.

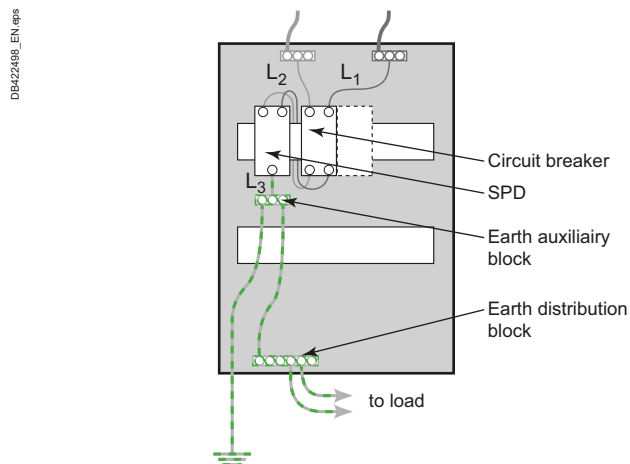


Fig. J39 Example of connection in plastic enclosure

J24

4.1.2 Connection in metallic enclosure

In the case of a switchgear assembly in a metallic enclosure, it may be wise to connect the SPD directly to the metallic enclosure, with the enclosure being used as a protective conductor (see Fig. J40).

This arrangement complies with standard IEC 61439-2 and the Assembly manufacturer must make sure that the characteristics of the enclosure make this use possible.

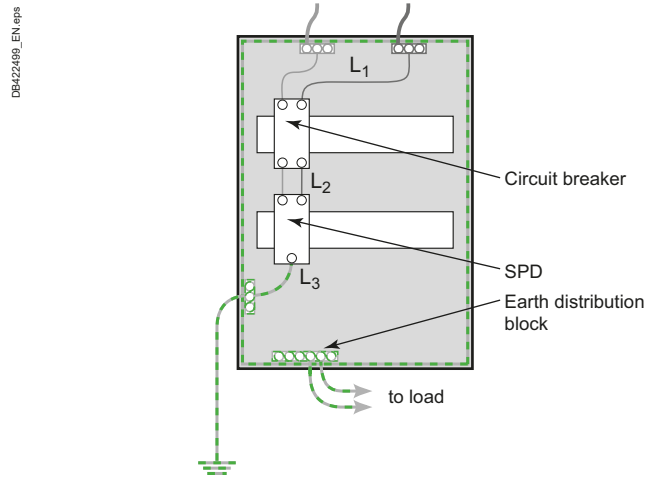


Fig. J40 Example of connection in metallic enclosure

4.1.3 Conductor cross section

The recommended minimum conductor cross section takes into account:

- The normal service to be provided: Flow of the lightning current wave under a maximum voltage drop (50 cm rule).

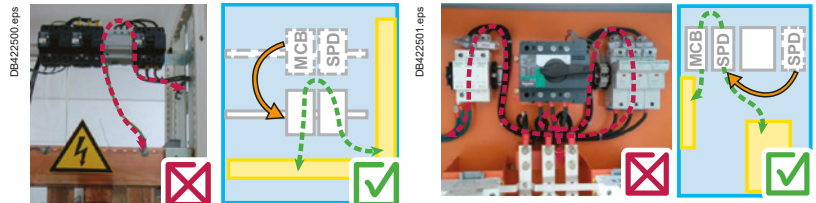
Note: Unlike applications at 50 Hz, the phenomenon of lightning being high-frequency, the increase in the conductor cross section does not greatly reduce its high-frequency impedance.

- The conductors' withstand to short-circuit currents: The conductor must resist a short-circuit current during the maximum protection system cutoff time.

IEC 60364 recommends at the installation incoming end a minimum cross section of:

- 4 mm² (Cu) for connection of Type 2 SPD;
- 16 mm² (Cu) for connection of Type 1 SPD (presence of lightning protection system).

4.1.4 Examples of good and bad SPD installations



Example 1:
Equipment installation design should be done in accordance to installation rules: cables length shall be less than 50 cm.

Example 2:
Positioning of devices should be linked to installation rules: reduce length of cables < 50 cm and keep the loop area rule of reducing impact of magnetic fields created by lightning current.

Fig. J41 Example of good and bad SPD installations

4 Installation of SPDs

4.2 Cabling rules

Rule 1:

The first rule to comply with is that the length of the SPD connections between the network (via the external SCPD) and the earthing terminal block should not exceed 50 cm.

Fig. J42 shows the two possibilities for connection of a SPD.

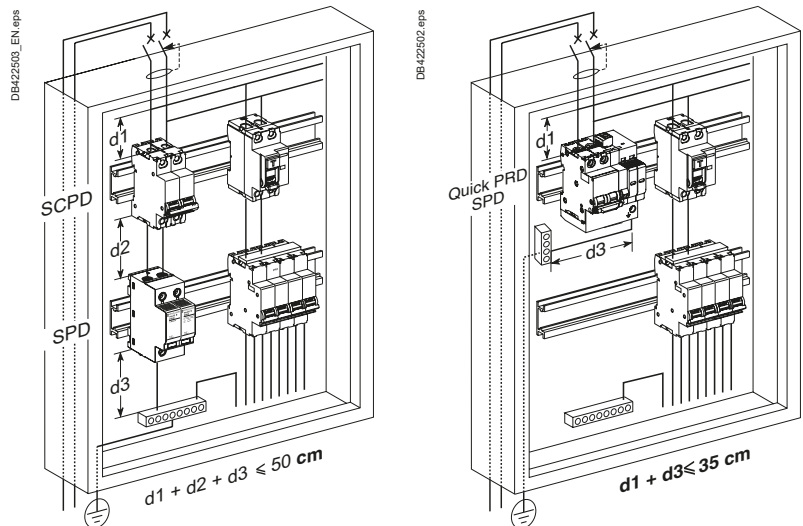


Fig. J42 SPD with separate or integrated external SCPD

Rule 2:

The conductors of protected outgoing feeders:

- should be connected to the terminals of the external SCPD or the SPD;
- should be separated physically from the polluted incoming conductors.

They are located to the right of the terminals of the SPD and the SCPD (see Fig. J43).

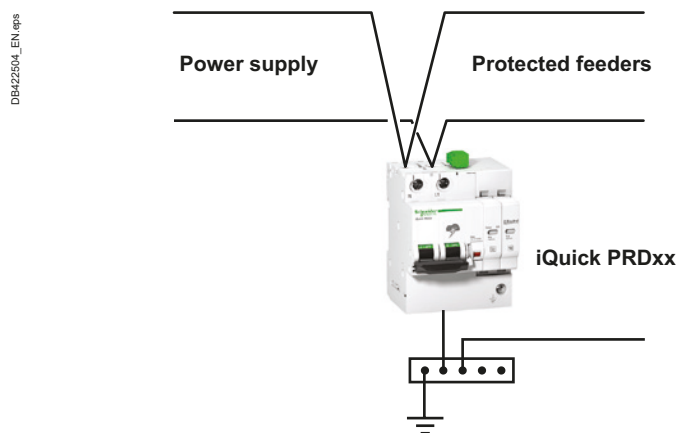


Fig. J43 The connections of protected outgoing feeders are to the right of the SPD terminals

J - Overvoltage protection

4 Installation of SPDs

Rule 3:

The incoming feeder phase, neutral and protection (PE) conductors should run one beside another in order to reduce the loop surface (see Fig. J44).

Rule 4:

The incoming conductors of the SPD should be remote from the protected outgoing conductors to avoid polluting them by coupling (see Fig. J44).

Rule 5:

The cables should be pinned against the metallic parts of the enclosure (if any) in order to minimize the surface of the frame loop and hence benefit from a shielding effect against EM disturbances.

In all cases, it must be checked that the frames of switchboards and enclosures are earthed via very short connections.

Finally, if shielded cables are used, big lengths should be avoided, because they reduce the efficiency of shielding (see Fig. J44).

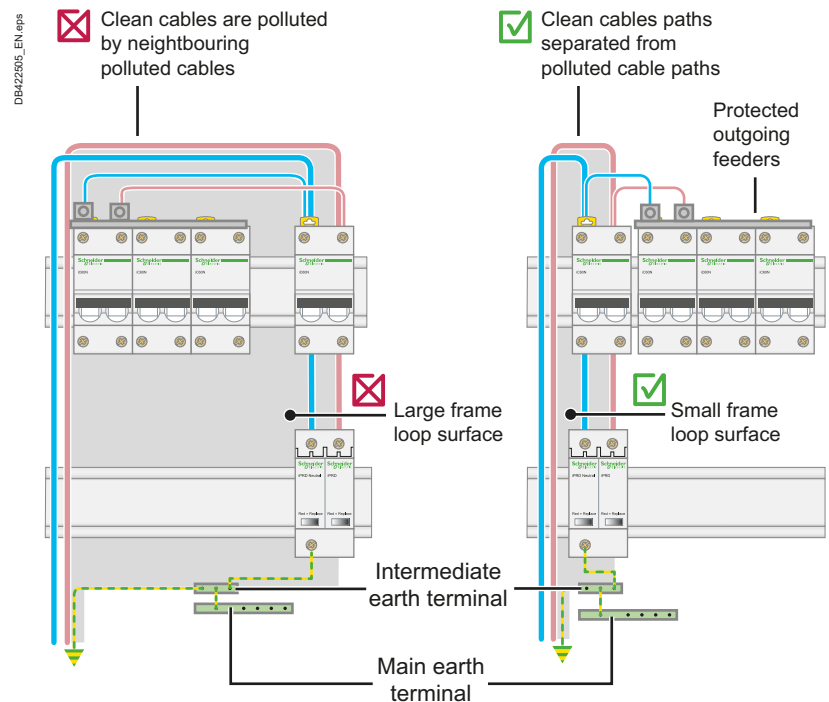


Fig. J44 Example of improvement of EMC by a reduction in the loop surfaces and common impedance in an electric enclosure

5.1 Installation examples

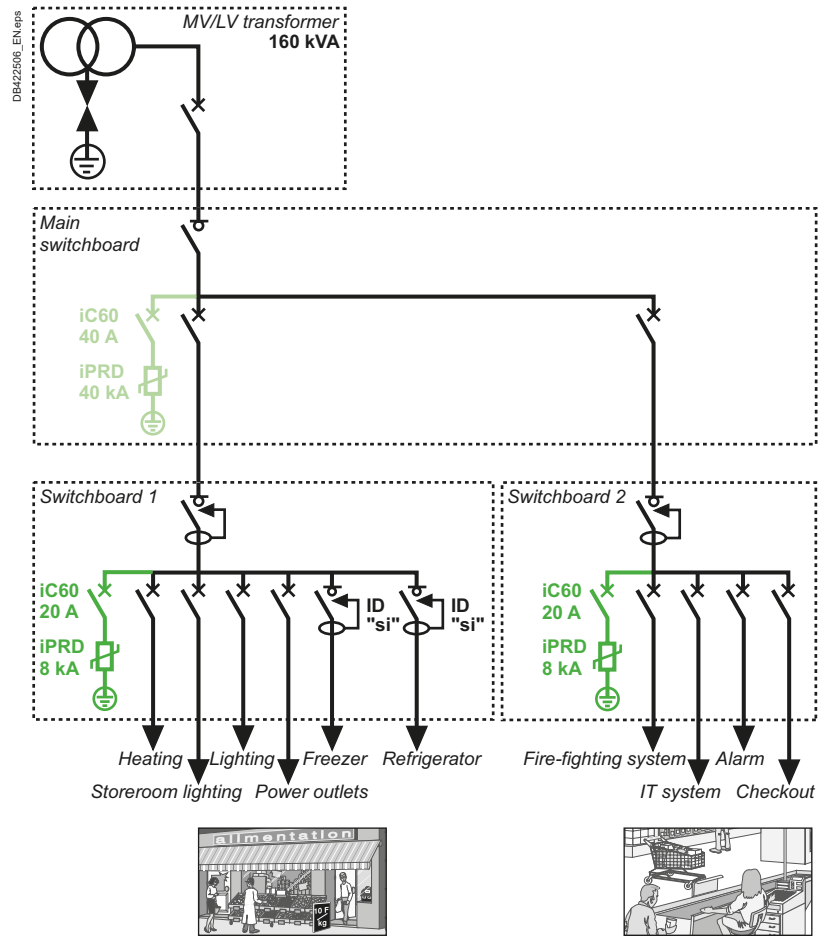


Fig. J45 Application example: supermarket

Solutions and schematic diagram

- The surge arrester selection guide has made it possible to determine the precise value of the surge arrester at the incoming end of the installation and that of the associated disconnection circuit breaker.
- As the sensitive devices ($U_{imp} < 1.5 \text{ kV}$) are located more than 10 m from the incoming protection device, the fine protection surge arresters must be installed as close as possible to the loads.
- To ensure better continuity of service for cold room areas:
 - «si» type residual current circuit breakers will be used to avoid nuisance tripping caused by the rise in earth potential as the lightning wave passes through.
- For protection against atmospheric overvoltages:
 - install a surge arrester in the main switchboard
 - install a fine protection surge arrester in each switchboard (1 and 2) supplying the sensitive devices situated more than 10 m from the incoming surge arrester
 - install a surge arrester on the telecommunications network to protect the devices supplied, for example fire alarms, modems, telephones, faxes.

Cabling recommendations

- Ensure the equipotentiality of the earth terminations of the building.
- Reduce the looped power supply cable areas.

Installation recommendations

- Install a surge arrester, $I_{max} = 40 \text{ kA}$ (8/20 μs) and a iC60 disconnection circuit breaker rated at 40 A.
- Install fine protection surge arresters, $I_{max} = 8 \text{ kA}$ (8/20 μs) and the associated iC60 disconnection circuit breakers rated at 10 A.

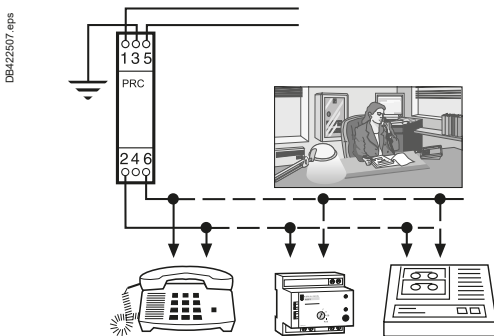


Fig. J46 Telecommunications network

5.2 SPD for Photovoltaic application

Overvoltage may occur in electrical installations for various reasons. It may be caused by:

- The distribution network as a result of lightning or any work carried out.
- Lightning strikes (nearby or on buildings and PV installations, or on lightning conductors).
- Variations in the electrical field due to lightning.

Like all outdoor structures, PV installations are exposed to the risk of lightning which varies from region to region. Preventive and arrest systems and devices should be in place.

5.2.1. Protection by equipotential bonding

The first safeguard to put in place is a medium (conductor) that ensures equipotential bonding between all the conductive parts of a PV installation.

The aim is to bond all grounded conductors and metal parts and so create equal potential at all points in the installed system.

5.2.2. Protection by surge protection devices (SPDs)

SPDs are particularly important to protect sensitive electrical equipments like AC/DC Inverter, monitoring devices and PV modules, but also other sensitive equipments powered by the 230 VAC electrical distribution network. The following method of risk assessment is based on the evaluation of the critical length L_{crit} and its comparison with L the cumulative length of the d.c. lines.

SPD protection is required if $L \geq L_{crit}$.

L_{crit} depends on the type of PV installation and is calculated as the following table (Fig. J47) sets out:

Type of installation	Individual residential premises	Terrestrial production plant	Service/Industrial/Agricultural/Buildings
L_{crit} (in m)	115/ N_g	200/ N_g	450/ N_g
$L \geq L_{crit}$	Surge protective device(s) compulsory on DC side		
$L < L_{crit}$	Surge protective device(s) compulsory on DC side		

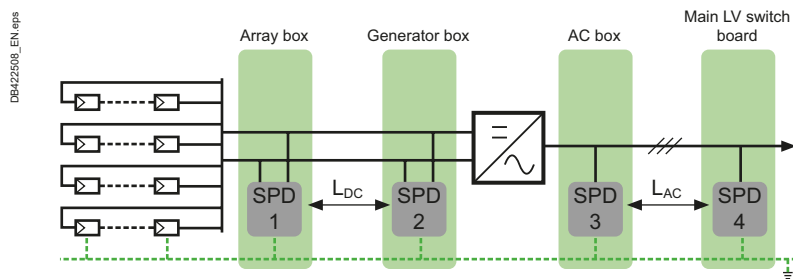
Fig. J47 SPD DC choice

L is the sum of:

- the sum of distances between the inverter(s) and the junction box(es), taking into account that the lengths of cable located in the same conduit are counted only once, and
- the sum of distances between the junction box and the connection points of the photovoltaic modules forming the string, taking into account that the lengths of cable located in the same conduit are counted only once.

N_g is arc lightning density (number of strikes/km²/year).

5 Application



SPD Protection							
Location	PV modules or Array boxes		Inverter DC side	Inverter AC side		Main board	
	L_{DC}			L_{AC}		Lightning rod	
Criteria	< 10 m	> 10 m		< 10 m	> 10 m	Yes	No
Type of SPD	No need	"SPD 1" Type 2*	"SPD 2" Type 2*	No need	"SPD 3" Type 2*	"SPD 4" Type 1*	"SPD 4" Type 2 if Ng > 2,5 & overhead line

* Type 1 separation distance according to EN 62305 is not observed.

Fig. J48 SPD selection

J30

Installing an SPD

The number and location of SPDs on the DC side depend on the length of the cables between the solar panels and inverter. The SPD should be installed in the vicinity of the inverter if the length is less than 10 metres. If it is greater than 10 metres, a second SPD is necessary and should be located in the box, close to the solar panel, the first one is located in the inverter area.

To be efficient, SPD connection cables to the L+ / L- network and between the SPD's earth terminal block and ground busbar must be as short as possible – less than 2.5 metres ($d1+d2 < 50$ cm).

5 Application

Safe and reliable photovoltaic energy generation

Depending on the distance between the «generator» part and the «conversion» part, it may be necessary to install two surge arresters or more, to ensure protection of each of the two parts.

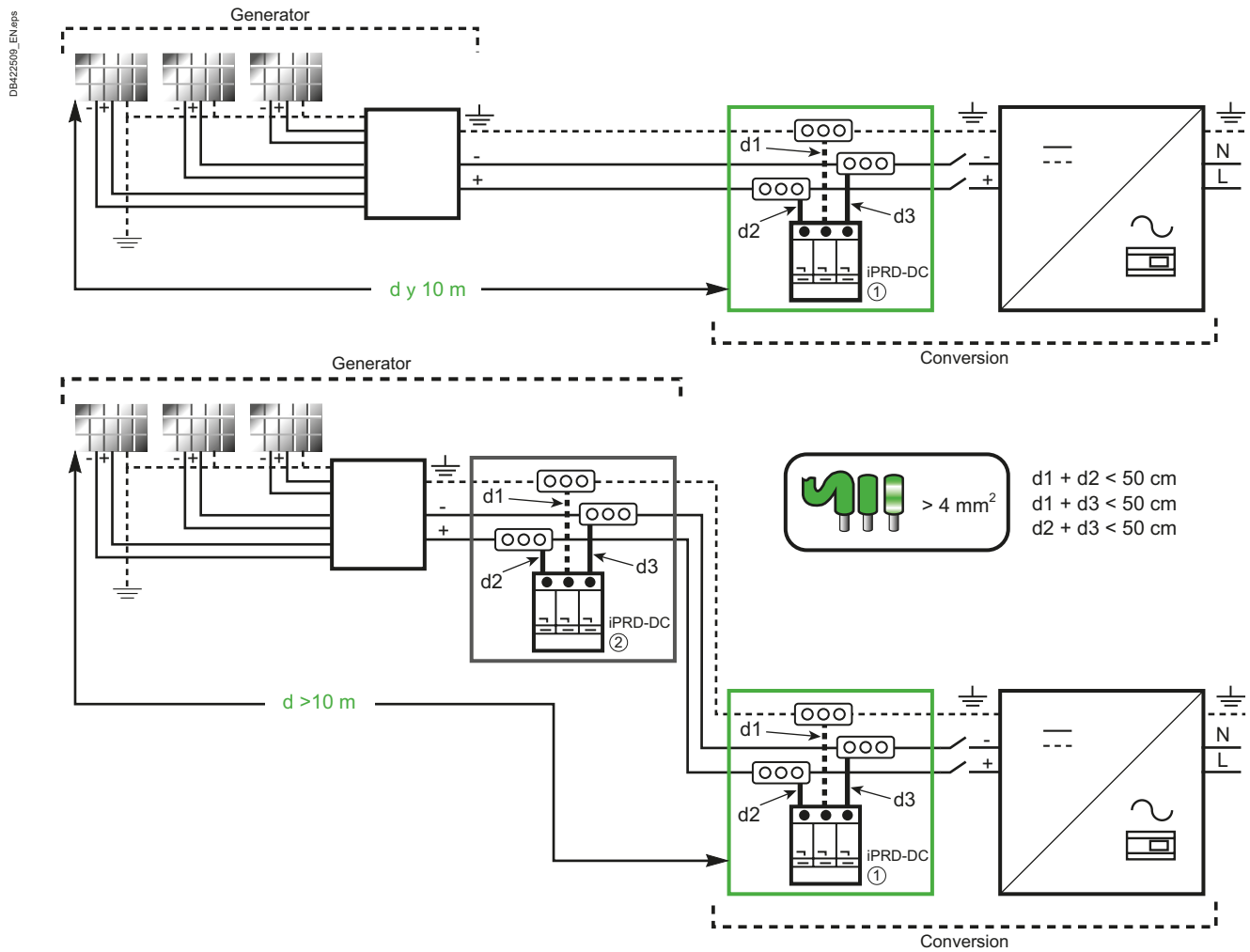


Fig. J49 SPD location

6.1 Lightning protection standards

The IEC 62305 standard parts 1 to 4 (NF EN 62305 parts 1 to 4) reorganizes and updates the standard publications IEC 61024 (series), IEC 61312 (series) and IEC 61663 (series) on lightning protection systems.

■ Part 1 - General principles:

This part presents general information on lightning and its characteristics and general data, and introduces the other documents.

■ Part 2 - Risk management:

This part presents the analysis making it possible to calculate the risk for a structure and to determine the various protection scenarios in order to permit technical and economic optimization.

■ Part 3 - Physical damage to structures and life hazard:

This part describes protection from direct lightning strokes, including the lightning protection system, down-conductor, earth lead, equipotentiality and hence SPD with equipotential bonding (Type 1 SPD).

■ Part 4 - Electrical and electronic systems within structures:

This part describes protection from the induced effects of lightning, including the protection system by SPD (Types 2 and 3), cable shielding, rules for installation of SPD, etc.

This series of standards is supplemented by:

■ the IEC 61643 series of standards for the definition of surge protection products (see sub-section 2);

■ the IEC 60364-4 and -5 series of standards for application of the products in LV electrical installations (see sub-section 3).

J32

6.2 The components of a SPD

The SPD chiefly consists of (see Fig. J50):

- 1) one or more nonlinear components: the live part (varistor, gas discharge tube, etc.);
 - 2) a thermal protective device (internal disconnecter) which protects it from thermal runaway at end of life (SPD with varistor);
 - 3) an indicator which indicates end of life of the SPD;
- Some SPDs allow remote reporting of this indication;
- 4) an external SCPD which provides protection against short circuits (this device can be integrated into the SPD).

DB442510.eps

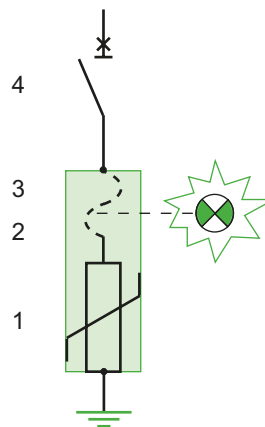


Fig. J50 Diagram of a SPD

6 Technical supplements

6.2.1 Technology of the live part

Several technologies are available to implement the live part. They each have advantages and disadvantages:

- Zener diodes;
- The gas discharge tube (controlled or not controlled);
- The varistor (zinc oxide varistor).

The table below shows the characteristics and the arrangements of 3 commonly used technologies.

Component	Gas Discharge Tube (GDT)	Encapsulated spark gap	Zinc oxide varistor	GDT and varistor in series	Encapsulated spark gap and varistor in parallel
Characteristics					
Operating mode	Voltage switching	Voltage switching	Voltage limiting	Voltage-switching and -limiting in series	Voltage-switching and -limiting in parallel
Operating curves					
Application	<ul style="list-style-type: none"> ■ Telecom network ■ LV network (associated with varistor) 	LV network	LV network	LV network	LV network
Type	Type 2	Type 1	Type 1 or Type 2	Type 1 + Type 2	Type 1 + Type 2

Fig. J51 Summary performance table

Note: Two technologies can be installed in the same SPD (see Fig. J52)

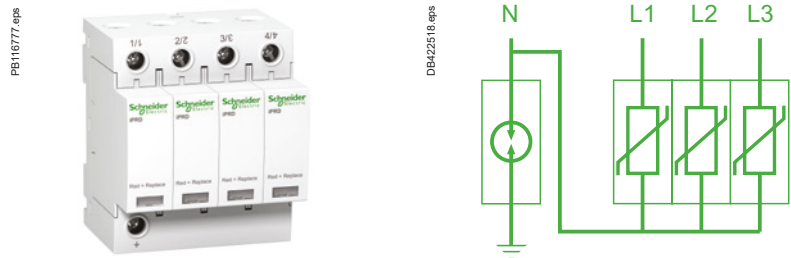


Fig. J52 The Schneider Electric brand iPRD SPD incorporates a gas discharge tube between neutral and earth and varistors between phase and neutral

PE118778.eps



Fig. J53 iQuick PRD 3P+N SPD of the Schneider Electric brand

DB422519.eps

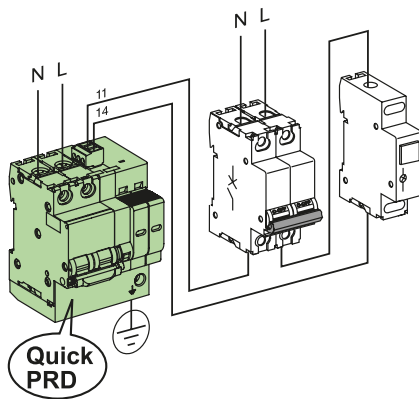


Fig. J54 Installation of indicator light with a iQuick PRD SPD

J34

DB422520.eps

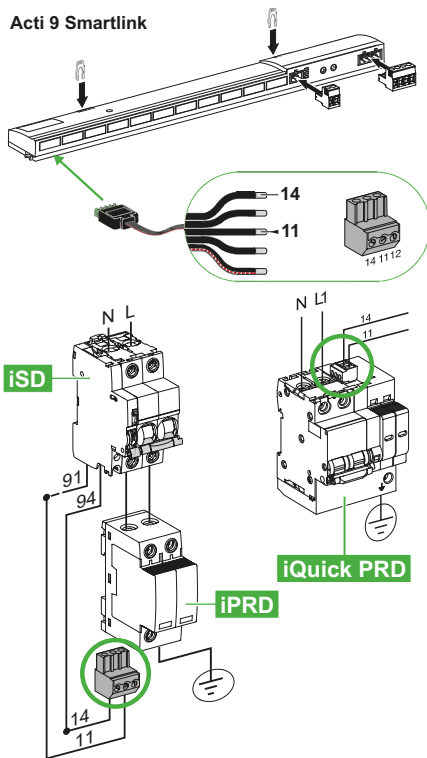


Fig. J55 Remote indication of SPD status using Smartlink

6.3 End-of-life indication

End-of-life indicators are associated with the internal disconnecter and the external SCPD of the SPD to inform the user that the equipment is no longer protected against overvoltages of atmospheric origin.

Local indication

This function is generally required by the installation codes.

The end-of-life indication is given by an indicator (luminous or mechanical) to the internal disconnecter and/or the external SCPD.

When the external SCPD is implemented by a fuse device, it is necessary to provide for a fuse with a striker and a base equipped with a tripping system to ensure this function.

Integrated disconnecting circuit breaker

The mechanical indicator and the position of the control handle allow natural end-of-life indication.

6.3.1 Local indication and remote reporting

iQuick PRD SPD of the Schneider Electric brand is of the «ready to wire» type with an integrated disconnecting circuit breaker.

Local indication

iQuick PRD SPD (see **Fig. J53**) is fitted with local mechanical status indicators:

- the (red) mechanical indicator and the position of the disconnecting circuit breaker handle indicate shutdown of the SPD;
- the (red) mechanical indicator on each cartridge indicates cartridge end of life.

Remote reporting (see **Fig. J54**)

iQuick PRD SPD is fitted with an indication contact which allows remote reporting of:

- cartridge end of life;
- a missing cartridge, and when it has been put back in place;
- a fault on the network (short circuit, disconnection of neutral, phase/neutral reversal);
- local manual switching.

As a result, remote monitoring of the operating condition of the installed SPDs makes it possible to ensure that these protective devices in standby state are always ready to operate.

6.3.2 Maintenance at end of life

When the end-of-life indicator indicates shutdown, the SPD (or the cartridge in question) must be replaced.

In the case of the iQuick PRD SPD, maintenance is facilitated:

- The cartridge at end of life (to be replaced) is easily identifiable by the Maintenance Department.
- The cartridge at end of life can be replaced in complete safety, because a safety device prohibits closing of the disconnecting circuit breaker if a cartridge is missing.

6.4 Detailed characteristics of the external SCPD

6.4.1 Current wave withstand

The current wave withstand tests on external SCPDs show as follows:

- For a given rating and technology (NH or cylindrical fuse), the current wave withstand capability is better with an aM type fuse (motor protection) than with a gG type fuse (general use).
- For a given rating, the current wave withstand capability is better with a circuit breaker than with a fuse device.

Fig. J56 below shows the results of the voltage wave withstand tests:

- to protect a SPD defined for $I_{max} = 20 \text{ kA}$, the external SCPD to be chosen is either a MCB 16 A or a Fuse aM 63 A,

Note: in this case, a Fuse gG 63 A is not suitable.

- to protect a SPD defined for $I_{max} = 40 \text{ kA}$, the external SCPD to be chosen is either a MCB 40 A or a Fuse aM 125 A,

6 Technical supplements

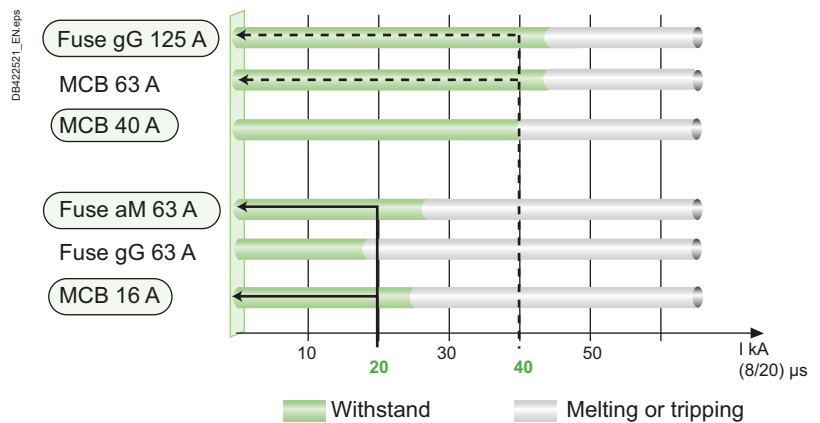


Fig. J56 Comparison of SCPDs voltage wave withstand capabilities for $I_{max} = 20 \text{ kA}$ and $I_{max} = 40 \text{ kA}$

6.4.2 Installed Up voltage protection level

In general:

- The voltage drop across the terminals of a circuit breaker is higher than that across the terminals of a fuse device. This is because the impedance of the circuit-breaker components (thermal and magnetic tripping devices) is higher than that of a fuse.

However:

- The difference between the voltage drops remains slight for current waves not exceeding 10 kA (95% of cases);
- The installed Up voltage protection level also takes into account the cabling impedance. This can be high in the case of a fuse technology (protection device remote from the SPD) and low in the case of a circuit-breaker technology (circuit breaker close to, and even integrated into the SPD).

Note: The installed Up voltage protection level is the sum of the voltage drops:

- in the SPD;
- in the external SCPD;
- in the equipment cabling.

J35

6.4.3 Protection from impedant short circuits

An impedant short circuit dissipates a lot of energy and should be eliminated very quickly to prevent damage to the installation and to the SPD.

Fig. J57 compares the response time and the energy limitation of a protection system by a 63 A aM fuse and a 25 A circuit breaker.

These two protection systems have the same 8/20 μs current wave withstand capability (27 kA and 30 kA respectively).

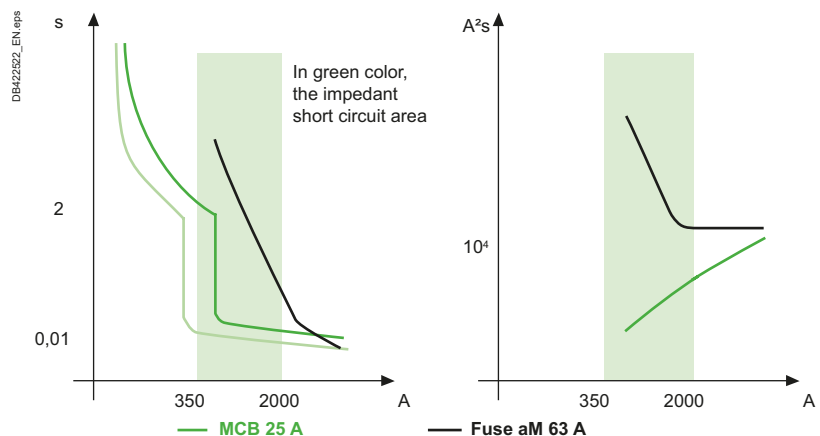


Fig. J57 Comparison of time/current and energy limitations curves for a circuit breaker and a fuse having the same 8/20 μs current wave withstand capability

6.5 Propagation of a lightning wave

Electrical networks are low-frequency and, as a result, propagation of the voltage wave is instantaneous relative to the frequency of the phenomenon: at any point of a conductor, the instantaneous voltage is the same.

The lightning wave is a high-frequency phenomenon (several hundred kHz to a MHz):

- The lightning wave is propagated along a conductor at a certain speed relative to the frequency of the phenomenon. As a result, at any given time, the voltage does not have the same value at all points on the medium (see Fig. J58).

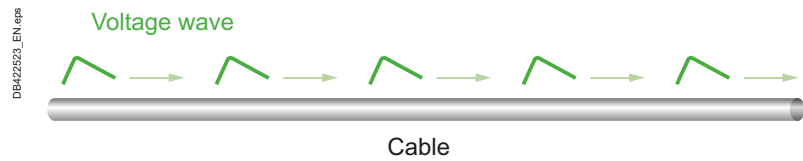


Fig. J58 Propagation of a lightning wave in a conductor

- A change of medium creates a phenomenon of propagation and/or reflection of the wave depending on:
 - the difference of impedance between the two media;
 - the frequency of the progressive wave (steepness of the rise time in the case of a pulse);
 - the length of the medium.

In the case of total reflection in particular, the voltage value may double.

Example: case of protection by a SPD

Modelling of the phenomenon applied to a lightning wave and tests in laboratory showed that a load powered by 30 m of cable protected upstream by a SPD at voltage U_i sustains, due to reflection phenomena, a maximum voltage of $2 \times U_i$ (see Fig. J59). This voltage wave is not energetic.

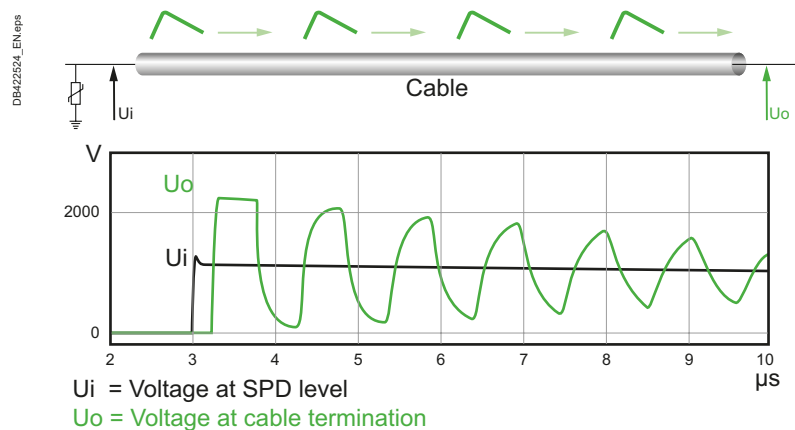


Fig. J59 Reflection of a lightning wave at the termination of a cable

Corrective action

Of the three factors (difference of impedance, frequency, distance), the only one that can really be controlled is the length of cable between the SPD and the load to be protected. The greater this length, the greater the reflection.

Generally for the overvoltage fronts faced in a building, reflection phenomena are significant from 10 m and can double the voltage from 30 m (see Fig. J60).

It is necessary to install a second SPD in fine protection if the cable length exceeds 10 m between the incoming-end SPD and the equipment to be protected.

J36

DB422526_EN.eps

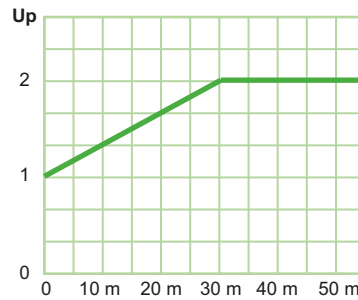


Fig. J60 Maximum voltage at the extremity of the cable according to its length to a front of incident voltage = 4kV/us

6.6 Example of lightning current in TT system

Common mode SPD between phase and PE or phase and PEN is installed whatever type of system earthing arrangement (see Fig. J61).

The neutral earthing resistor R1 used for the pylons has a lower resistance than the earthing resistor R2 used for the installation.

The lightning current will flow through circuit ABCD to earth via the easiest path. It will pass through varistors V1 and V2 in series, causing a differential voltage equal to twice the U_p voltage of the SPD ($U_{p1} + U_{p2}$) to appear at the terminals of A and C at the entrance to the installation in extreme cases.

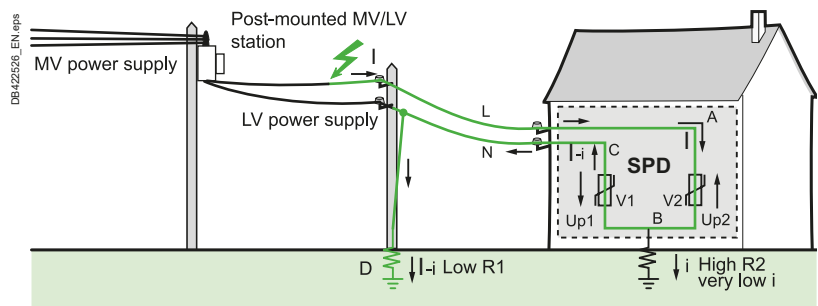


Fig. J61 Common protection only

To protect the loads between Ph and N effectively, the differential mode voltage (between A and C) must be reduced.

Another SPD architecture is therefore used (see Fig. J62)

The lightning current flows through circuit ABH which has a lower impedance than circuit ABCD, as the impedance of the component used between B and H is null (gas filled spark gap). In this case, the differential voltage is equal to the residual voltage of the SPD (U_{p2}).

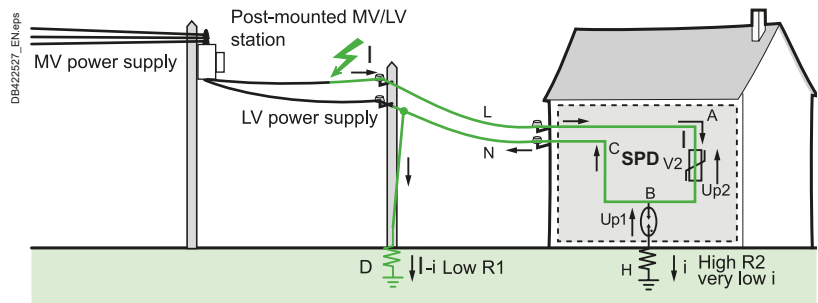


Fig. J62 Common and differential protection

J37

Energy efficiency in electrical distribution

1	Energy Efficiency in brief	K2
2	Energy efficiency and electricity	K3
	2.1 An international appetite for regulation.....	K3
	2.2 Energy Efficiency standards.....	K4
	2.3 IEC 60364-8-1 standard.....	K7
	2.4 Practical considerations.....	K9
3	Diagnostics through electrical measurement	K10
	3.1 Electrical measurements.....	K10
	3.2 How to select relevant measuring instruments.....	K10
4	Energy saving opportunities	K13
	4.1 Motor-related savings opportunities.....	K13
	4.2 Lighting.....	K16
	4.3 Power factor correction and harmonic filtering.....	K18
	4.4 Load management.....	K19
	4.5 Communication and information systems.....	K20
	4.6 Smart panels.....	K23
5	How to evaluate energy savings	K28
	5.1 IPMVP and EVO procedures.....	K28
	5.2. Achieving sustainable performance.....	K30

1 Energy Efficiency in brief

World energy consumption continues to grow with no perspective of slowing down in the near future. This trend is driven by different factors, both economical and sociological:

- **An increase in the world population**, particularly in countries where the energy use per person is expected to grow in the future. For example, today, over one billion people have no access to electricity, and around 40% of the world's population is living under water stress. This means that the energy needs will increase in the future, in order to allow people to benefit from a better standard of living. This additional energy need is globally not compensated by a decrease of energy consumption in developed countries. According to the International Energy Agency, the average energy use per person increased by 10% between 1990 and 2008.

- **Urbanization and industrialization**, particularly in developing countries. This means that more energy will be needed for construction, manufacturing, and transportation of people and goods

The major part of energy is today obtained by burning fossil fuels (around 82% in 2012). The consequence of this is the emission of huge quantities of CO₂ (32 billion tons in 2014), which has an accepted impact on climate change by greenhouse effect.

In addition, these fossil fuels are subject to fluctuation in prices, because of geopolitical issues and competition between countries.

For these reasons, there is a global commitment of countries to curb the use of fossil fuels. The Kyoto protocol was the first international agreement by which industrialized countries set objectives to reduce the greenhouse gas emission. Such a commitment has been confirmed during the Conference of Parties (COP 21) in 2015, with the objective to limit global warming within acceptable limits (maximum 2°, and possibly 1.5°C).

In order to reach these objectives, different regulations have already been put in place in many countries, relative to energy efficient construction for example.

One of the solutions proposed to solve the dilemma between economic development and CO₂ emission is to increase the part of electricity in the energy mix. Production of electricity represents around 30% of fossil fuels consumed worldwide, and 68% of electricity is produced from the combustion of fossil fuels (coal, oil, and natural gas).

So actions that must be taken should include:

- Development of the use of **renewable energies** (mainly solar and wind). Unfortunately, cost is still an issue, particularly during periods when the price of fossil fuels is low. The other major issue is the fluctuating nature of solar and wind generation. Energy storage is needed, which can significantly increase the cost yet again.

- **Energy Efficiency**. The objective is to provide the same level of service by consuming less energy. By implementing energy efficient electrical equipment and smart controllers, it is possible to save up to 30% of energy. This is the most cost effective means for limiting CO₂ emissions, and saving energy and cost.

Here are the main points presented in this chapter:

- Overview of worldwide standardization and Energy Efficiency assessment techniques,
- Presentation of electrical measurement as the key diagnostics tool,
- Overview of energy savings opportunities in Electrical Installations.

2 Energy efficiency and electricity

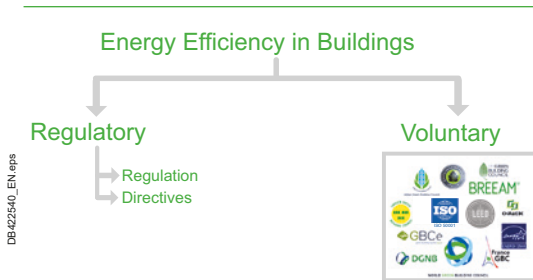


Fig. K1 Regulatory vs voluntary approach to Energy Efficiency in Buildings

2.1 An international appetite for regulation

As shown in Fig. K1, Energy Efficiency in Buildings can be the result of:

- Regulatory measures, with the evolution of regulations and directives (and of the related standards) which can be issued at national or international levels
- or voluntary approach, with Green Building certification systems such as Leed, Breeam, etc ... Promoters, building owners, occupiers etc may decide to have their building certified to help adopt sustainable solutions, and to obtain market recognition of their achievements.

2.1.1 Energy Efficiency regulations in Europe

Europe has issued 2 directives which emphasize the need for improvement in Energy Efficiency.

Energy Efficiency Directive (EED)

The 2012 Energy Efficiency Directive establishes a set of binding measures to help the EU reach its 20% energy efficiency target by 2020. Under the Directive, all EU countries are required to use energy more efficiently at all stages of the energy chain from its production to its final consumption.

In particular, any company with more than 250 employees has either to perform regularly an Energy Audit, or has to put in place a permanently installed Energy Management System, as described in Fig. K2.

The directive requirements are minimum requirements and shall not prevent any member state from maintaining or introducing more stringent measures.

Energy Performance of Buildings Directive (EPBD)

This directive came into force on 4 January 2006, and lays down Energy performance requirements such as:

- All new buildings should be Near Zero energy by 31 Dec 2020
- Energy performance certificates are to be included in all advertisements for the sale or rental of buildings
- EU countries must establish inspection schemes for heating and air conditioning systems or put in place measures with equivalent effect
- EU countries must set minimum energy performance requirements for new buildings, for the major renovation of buildings and for the replacement or retrofit of building elements (heating and cooling systems, roofs, walls, etc.).

EN 15232 standard applies for Building Management Systems (BMS) and Building Automation & Control Systems (BACS).

K3

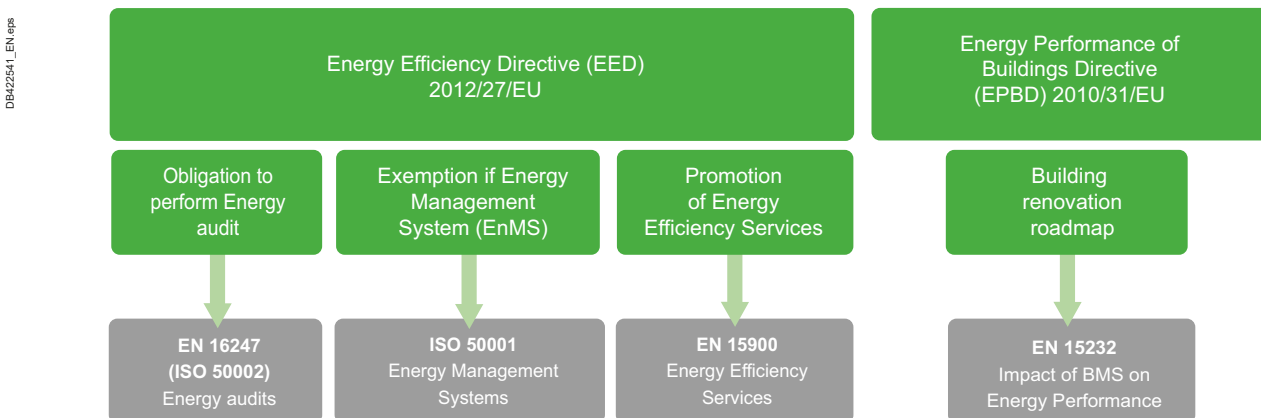


Fig. K2 Consistency between European regulations (in green) and standards (in grey)

2 Energy efficiency and electricity

2.1.2 Examples of green building certification systems

Many countries have issued green building certifications systems, some of them are listed as examples in **Fig. K3**:







Green building certification	Influence	First version release year
LEED (Leadership in Energy and Environmental Design)	USA	2009
BREEAM (Building Research Establishment Environmental Assessment Methodology)	UK	2008
NF HQE (Haute Qualité Environnementale)	FRANCE	2009
CASBEE (Comprehensive Assessment System for Built Environment Efficiency)	JAPAN	2004
DGNB (Deutsche Gesellschaft für Nachhaltiges Bauen)	GERMANY	2009

Fig. K3 Standards for Energy Efficiency, cost allocation & optimization

2.2 Energy Efficiency standards

2.2.1 Scope of application of standards

It is important to differentiate standards which apply to a complete site assessment, to standards which apply to measurement devices used to help site assessments, as shown in **Fig. K4**:

Assessment of a complete site	Assessment tools	Devices used to assess the site
 ISO 50001 Energy Management Systems – Requirements with guidance for use	 ISO 50006 Energy Baseline (EnBs) & Energy Performance Indicators (EnPIs)	PMD (Power Meters)  IEC 61557-12 Power Metering and Monitoring devices (PMD)
	 IEC 60364-8-1 Low voltage installations – Part 8-1: Energy Efficiency	Gateways, energy servers, data loggers  IEC 62974-1
	 FD X30-147^[a] Measurement plan for energy performance monitoring	Monitoring and measuring systems used for data collection, gathering and analysis – Part 1: Device requirements

[a] FD X30-147 is a guide published by AFNOR (French national organization for standardization), which specifies the requirements, methodology and deliverables for the design, implementation, operation, maintenance and improvement of a metering system.

Fig. K4 Standards for Energy Efficiency, cost allocation & optimization

2 Energy efficiency and electricity

2.2.2 ISO 50001

ISO 50001 «Energy management systems - Requirements with guidance for use» is the main international standard providing requirements on Energy management Systems (EnMS). It provides a framework of requirements for organizations to:

- Develop a policy for more efficient use of energy
- Fix targets and objectives to meet the policy
- Use data to better understand and make decisions about energy use
- Measure the results
- Review how well the policy works, and
- Continually improve energy management.

The Energy management system model required in ISO 50001 is described in **Fig. K5**:

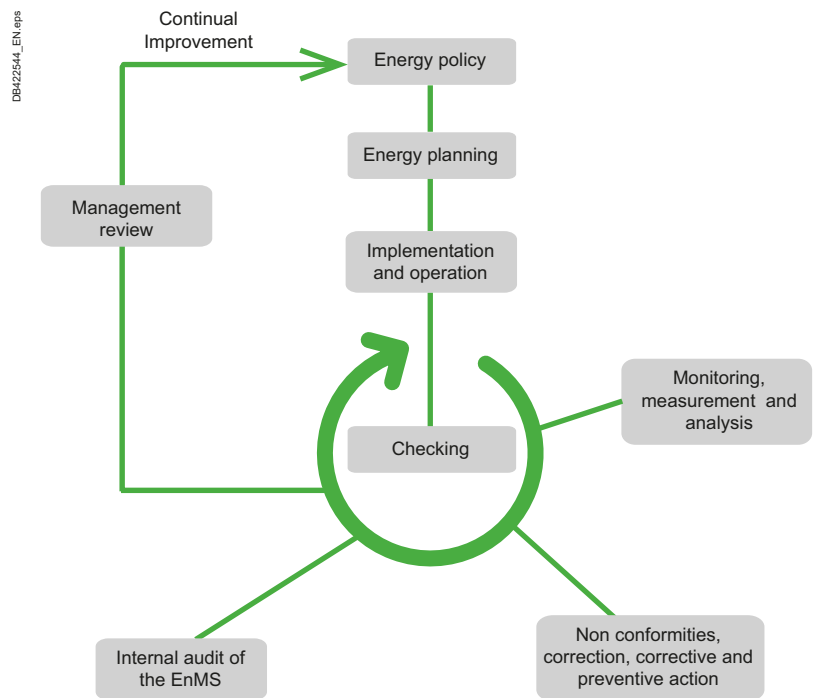


Fig. K5 Energy management system model for ISO 50001

2 Energy efficiency and electricity

2.2.3 ISO 50006

ISO 50006 is a companion standard of ISO 50001, providing practical guidance on how to monitor energy efficiency with the help of energy performance indicators (EnPI) measured on periods. Comparing EnPI between the **baseline period** and the **reporting period** means measuring energy efficiency improvements, see **Fig. K6**.

EnPI = value or measure that quantifies results related to energy efficiency, use and consumption in facilities, systems, processes and equipment as a whole or in part.

EnB = quantifies energy performance during a specified time period to be used as a **base reference** for comparing energy performance.

The organization should consider the specific **energy performance targets** while identifying and designing EnPIs and EnBs.

One element highlighted in ISO 50006 is the importance of defining and quantifying the factors or variables which may have an impact on energy consumption (such as external temperature, occupancy ...) in order to compare energy performance under equivalent conditions.

DIB4225-45_EN.eps

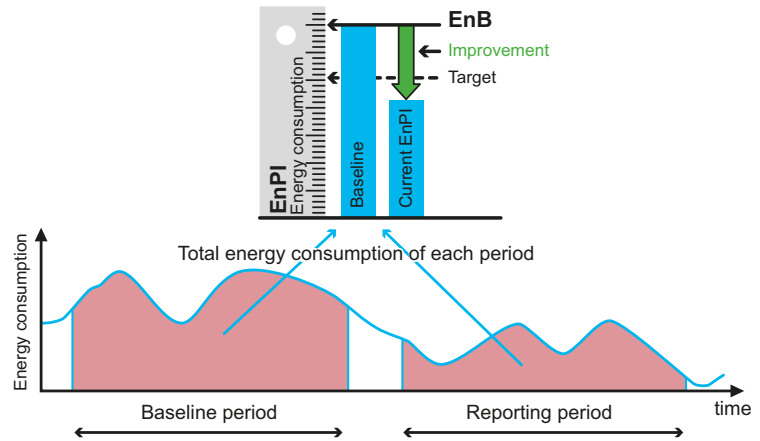


Fig. K6 Concept of Baseline period and Reporting period for EnPI

2 Energy efficiency and electricity

D84225-06_EN.eps

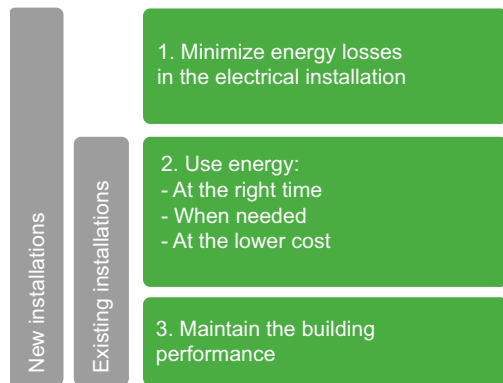


Fig. K7 Implementation of Energy Efficiency as per IEC60364-8-1

2.3 IEC 60364-8-1 standard

In the context of international regulation on Energy Efficiency, **IEC 60364-8-1** standard («Low voltage electrical installations – Energy efficiency») has been developed specifically for electrical installations.

The standard gives requirements and recommendations for the design of an electrical installation with an **energy efficiency** approach. This emphasizes the importance of Energy Efficiency in the design of electrical installations, in the same way as safety and implementation rules.

In manufacturing industry, Energy Efficiency can easily be defined by the quantity of energy (kWh) necessary to manufacture one product. For an electrical installation in a building particularly, Energy Efficiency is defined as a system approach, which objective is to optimize the use of electricity. This includes:

- Minimize energy losses,
- Use electricity at the right time and at the lower cost,
- Maintain the performance all along the installation life cycle.

Here are the main points to keep in mind while implementing Energy Efficiency approach in an electrical installation:

- There must be no conflict with the requirements relative to safety of people and property,
- There must be no deterioration of electrical energy availability,
- It is applicable to new and existing installations,
- It can be implemented anytime, the only point of consideration being the rhythm of investment,
- This is an iterative approach and improvements can be incremental. The ROI is the decision factor for implementation of new equipment dedicated to Energy Efficiency.

Technical guidance is provided on the design principles, taking into account the following aspects:

- Optimal location of the HV/LV substation and switchboard by using the barycenter method (see also chapter D of this guide, paragraph 7),
- Reduction of the wiring losses, by increasing the c.s.a. of cables and by implementation of Power Factor Correction and Harmonic mitigation,
- Determination of meshes or zones with equipment having similar energy requirements,
- Load management techniques,
- Installation of control and monitoring equipment.

An example of **assessment method** is given with 5 levels of performance, considering different aspects such as:

- Monitoring of load profile,
- Location and efficiency of the transformer substation,
- Optimization of motor, lighting and HVAC equipment efficiency.

For example, **Fig. K8** gives the recommended assessment levels for determination of load profile in kWh (EM: Efficiency Measures). Other assessment levels are defined (for harmonics levels ...), and are specified per type of activity: Residential (dwellings), commercial, industrial or infrastructure.

EM0	EM1	EM2	EM3	EM4
No consideration	Load profile consumption of the installation for a day	Load profile consumption of the installation for each day of a week	Load profile consumption of the installation for each day of a year	Permanent data logging of the load profile consumption of the installation

Fig. K8 Determination of load profile in kWh

It is important to note that the objective of Energy Efficiency is not only making energy savings. Implementation of Energy Efficiency must keep the same level of service and safety, maintain performance, while saving energy and money, at present and in the future.

2 Energy efficiency and electricity

Fig. K9 from IEC 60364-8-1 illustrates how to implement the electrical energy management system within the installation:

- Step 1: the inputs from the user shall be taken into account, such as the building temperature set point,
- Step 2: all sources of energy are considered, based on availability and real time price,
- Step 3: inputs from environmental data are taken into account to avoid inappropriate decisions, such as switch on the light during the day,
- Step 4: inputs from the load are extracted as they are key to verify the accuracy of the load profile,
- Step 5: detailed information on energy consumption are provided to the user,
- Step 6: decisions are taken relative to the loads such as load shedding,
- Step 7: decisions are taken relative to the sources of energy in order to deliver the service to the user at the lowest cost.

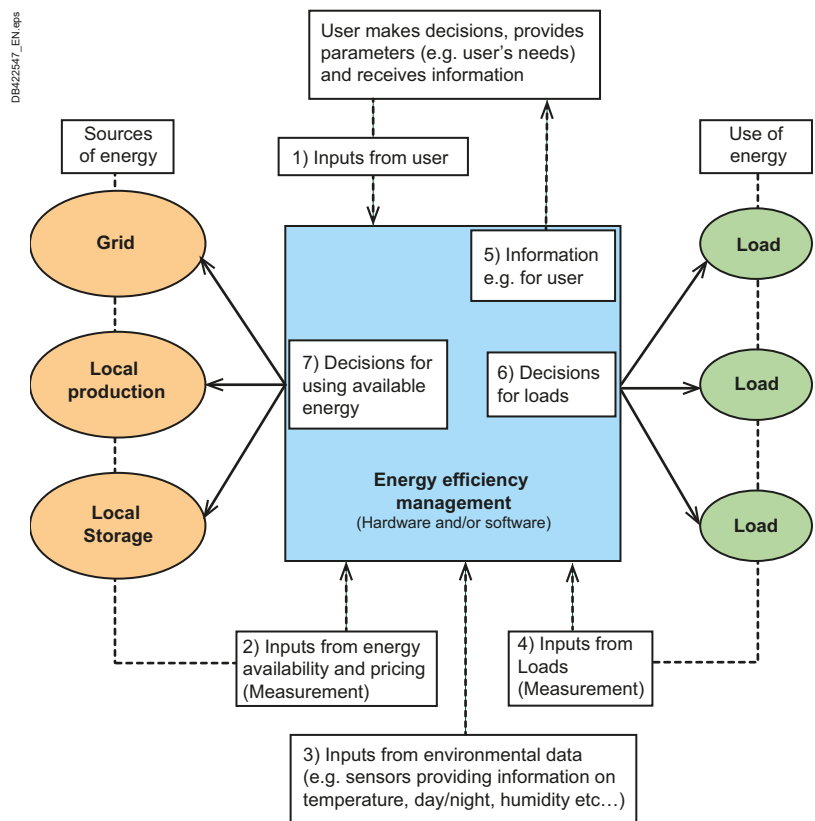


Fig. K9 Energy Efficiency and load management system

2 Energy efficiency and electricity

2.4 Practical considerations

Whilst it is currently possible to obtain energy savings of up to 30%, this potential reduction can only really be understood in terms of the differences which exist between active and passive forms of energy efficiency.

Active and passive energy efficiency

Passive energy efficiency is achieved by such measures as reducing heat loss and using equipment which requires little energy.

Active energy efficiency is achieved by putting in place an infrastructure for measuring, monitoring and controlling energy use with a view to making lasting changes. (see Fig. K10).

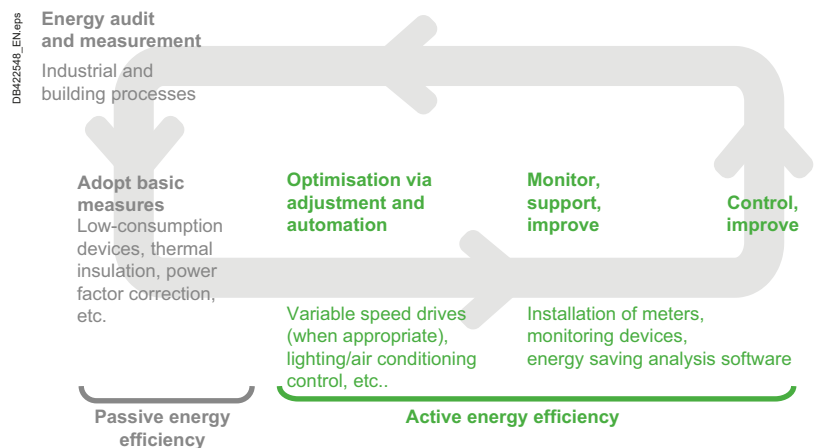


Fig. K10 Energy efficiency solutions based on the life cycle

Savings from 5% to 15% may be easily obtained by implementation of passive energy efficiency. Typical measures include decommissioning redundant systems, use of high efficiency motors and lighting, Power Factor Correction. More significant savings can be achieved by implementation of active energy efficiency measures. Typically:

- Up to 40% on energy for motors by using control and automation mechanisms to manage motorized systems,
- Up to 30% on lighting by introducing an automated management mechanism based on optimal use.

Active energy efficiency does not require highly energy-efficient devices and equipment to be already installed, as the approach can be applied to all types of equipment. Good management is essential for maximum efficiency – there is no point in having low-consumption bulbs if you are going to waste energy by leaving them switched on in empty rooms!

It is important to remember, however, that savings may be lost through:

- Unplanned/unmanaged downtime affecting equipment and processes,
- A lack of automation/adjustment mechanisms (motors, heating)
- A failure to ensure that energy saving measures are adopted at all times.

In addition, when the operator's electrical network is expected to undergo frequent changes given the activities in which it is involved, these changes should prompt a search for immediate and significant optimization measures.

Approaches to energy efficiency also need to take other parameters into account (temperature, light, pressure, etc.), since, assuming energy is transformed without any losses, the energy consumed by a piece of equipment may exceed the useful energy it produces. One example of this is a motor, which converts part of the energy it consumes into heat in addition to mechanical energy.

3 Diagnostics through electrical measurement

3.1 Electrical measurements

The first step in an Energy Efficiency approach is to establish a diagnosis and primarily aims to get a better idea of where and how energy is being consumed. This requires the development of initial measures and a comparative assessment process with a view to evaluating performance, defining the main areas for improvement and estimating achievable energy saving levels. The logic behind this approach is based on the realization that «you can only improve what you can measure».

With a large scope and detailed list of requirements, **IEC 61557-12** is applicable to measuring devices addressing most applications in switchboards and panels worldwide. See in **chapter 5** the sub-clause related to this standard.

Stand-alone Power Measurement Devices are the natural solution of obtaining relevant data at the most important points in the electrical installation. A large range of devices is available from manufacturers, covering the full range of voltage and current, providing data about a large number of different electrical quantities (voltage, current, power, energy, etc.), with local display or remote communication capabilities.

However, many advantages can be gained by combining the functions of measurement and protection in one single device.

Firstly, this approach leads to a reduction in equipment installation costs: installing one single device costs less than installing two. And combining these two functions in the same unit ensures the right sizing of current sensors, and eliminates risks of connection errors and guarantees correct operation, with the whole unit tested in the factory.

Examples of architectures including both types of devices are presented in **§ 4.6: Smart panels**.

3.2 How to select relevant measuring instruments

French standard AFNOR “**FD X30-147 Measurement plan – design and implementation**” published in November 2015 and described hereafter is currently the most advanced document about concrete ways to build a measurement plan.

This document proposes 3 levels of achievement:

- Base level
- Medium level
- Advanced level

Tables in Annex F of this standard define the appropriate measurements required to achieve each level of achievement of the measurement system. Some extracts are shown in following paragraphs.

3.2.1 Measurement by zone or by mesh

Measurement of active energy need to be achieved zone by zone, or mesh by mesh:

Measurement to be done	Relevant measurements		
	Base	Medium (in addition to base)	Advanced (in addition to medium)
For each zone or mesh	Active energy	Reactive energy Apparent energy Power	-

Fig. K11 Appropriate measurements for electrical energy

K10

3 Diagnostics through electrical measurement

3.2.2 Measurement by usage

Attention should be put on measurement by usage that can be helpful to determine potential sources of energy efficiency improvements:

Measurement to be done	Relevant measurements		
	Base	Medium (in addition to base)	Advanced (in addition to medium)
HVAC	Active energy	Internal temperature Hygrometry Coefficient of Performance (COP)	-
Lighting	Active energy	-	-
Appliances	Active energy	-	-
Motors	Active energy	Reactive energy	THDi Unb (Unbalance)

Fig. K12 Appropriate measurements for electrical energy

3.2.3 Measurement of relevant variables

ISO 50006 is providing guidance on «energy base line» and on “Energy Performance Indicators”. These items are mixing energy measurement with other relevant parameters, e.g. measurement of energy consumption correlated with degree-day, or energy consumption related to the number of persons present within a plant, or other influencing parameters.

All these relevant parameters need to be measured or estimated or transferred from another database.

Measurement to be done	Relevant variables		
	Base	Medium (in addition to base)	Advanced (in addition to medium)
HVAC	Outside temperature (or degree day)	Inside temperatures Inside hygrometry Number of persons present or equivalent indicator (e.g. daily turnover)	HVAC Coefficient of Performance (COP) HVAC power
Lighting	Season	Natural lighting Number of persons present or equivalent indicator (e.g. daily turnover)	-
Appliances	-	Number of persons present or equivalent indicator (e.g. daily turnover)	-
Motors	-	Surrounding temperature	-
Generators	-	Surrounding temperature	-

Fig. K13 Appropriate measurements of influencing factors according to uses

K11

3 Diagnostics through electrical measurement

3.2.4 Monitoring of electrical installation

It is also important to monitor the electrical distribution system, because some measurements can reveal some issues with energy efficiency, and additionally some risks related to assets.

Measurement to be done		Relevant measurements		
		Base	Medium (in addition to base)	Advanced (in addition to medium)
Delivery point	At delivery point	Active energy	Voltage, Current, Power Factor, active/reactive energy and power, THDu and THDi, frequency	Individual harmonics voltage and current
Distribution Switchboard	- for each feeder with at least 100kVA power (e.g. : 160A, 400V tri)	Active energy	Voltage, Current, Power Factor, active/reactive energy and power, THDu and THDi, frequency	Individual harmonics voltage and current
	- for each feeder with at least 40kVA power (e.g. : 63A, 400V tri)	-	Voltage, Current, Power Factor, active/reactive energy and power	THDu and THDi
	- for each feeder with at least 3.5kVA power (e.g. : 16A, 230V single phase)	-	-	Active energy
Transformers	Transformers	-	Transformer efficiency	Voltage unbalance, upstream and downstream voltage

Fig. K14 Appropriate measurements according to the type of outgoing line, incoming line, generator or energy exchanger

4 Energy saving opportunities

A number of different measures can be adopted to save energy (see Fig. K15).

■ Reduce energy use

These measures try to achieve the same results by consuming less (e.g. installing highly energy-efficient lights which provide the same quality of light but consume less energy) or reduce energy consumption by taking care to use no more energy than is strictly necessary (e.g. another method would be to have fewer lights in a room which is too brightly lit).

■ Save energy

These measures reduce costs per unit rather than reducing the total amount of energy used. For example, day-time activities could be performed at night to in order to take advantage of cheaper rates. Similarly, work could be scheduled to avoid peak hours and demand response programmes.

■ Energy reliability

They not only contribute to operational effectiveness by avoiding production downtime, but also avoid the energy losses associated with frequent restarts and the additional work associated with batches of spoiled products.

DB422546_EN.npp

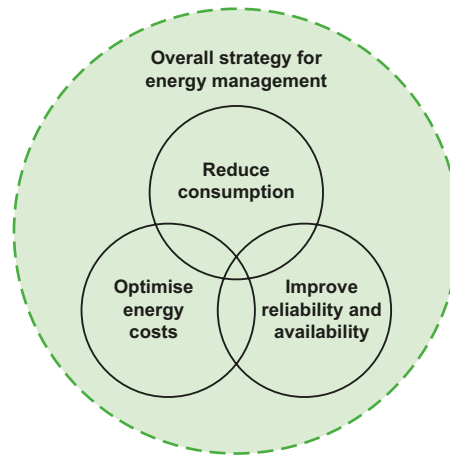


Fig. K15 An overall strategy for energy management

K13

Everyone immediately thinks of equipment for transforming energy (motors, lighting/heating devices) when considering areas where savings can be made. Less obvious, perhaps, are the potential savings offered by the various control devices and programmes associated with this type of equipment.

4.1 Motor-related savings opportunities

Motorised systems are one of the potential areas where energy savings can be made.

Many solutions exist to improve the energy efficiency of these motorized systems, as described below. You can also refer to the white paper «Energy efficiency of machines: the choice of motorization»

www.schneider-electric.com/ww/en/download/document/998-2095-02-04-12AR0_EN

Motors represent 80% of electrical energy consumption in the industry segment

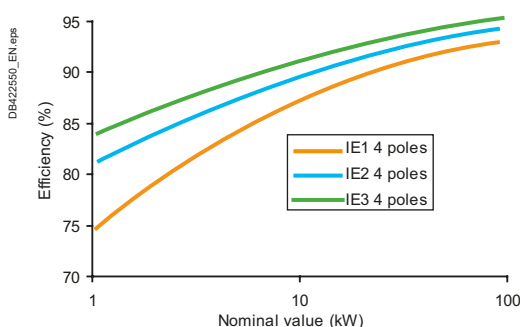


Fig. K16 Definition of energy efficiency classes for LV motors, according to Standard IEC60034-30

Choice/replacement of the motor

Those wishing to improve passive energy efficiency often consider replacing motors as a starting point, especially if the existing motors are old and require rewinding.

This trend is reinforced by the determination of major countries to stop low-efficiency motor sales in the near future.

Based on the IEC60034-30 Standard's definition of three efficiency classes (IE1, IE2, IE3), many countries have defined a plan to gradually force IE1 and IE2 motor sales to meet IE3 requirements.

In the EU, for example, motors of less than 375 kW have to be IE3-compliant by January 2015 (EC 640/2009).

4 Energy saving opportunities

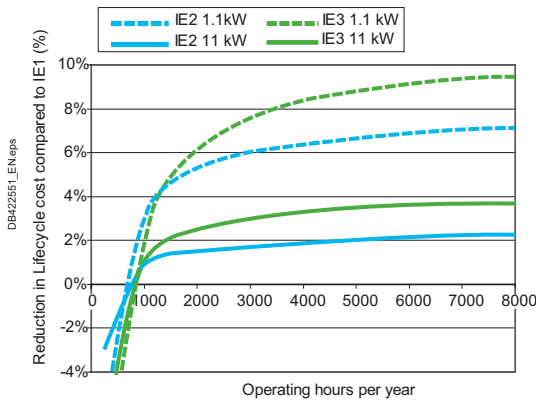


Fig. K17 Life cycle cost reduction for IE2 and IE3 motors compared to IE1 motors, depending on the number of operating hours per year

Savings can be made by:

- Replacing an oversized old motor with an appropriate high-efficiency motor
- Operating the motor cleverly
- Choosing an appropriate motor starter/controller

K14

There are two reasons for replacing an old motor:

- To benefit from the advantages offered by new high-performance motors (see Fig. K16)

Depending on their rated power, high-performance motors can improve operational efficiency by up to 10% compared to standard motors. By comparison, motors which have undergone rewinding see their efficiency reduced by 3% to 4% compared to the original motor.

- To avoid oversizing

In the past, designers tended to install oversized motors in order to provide an adequate safety margin and eliminate the risk of failure, even in conditions which were highly unlikely to occur. Studies show that at least one-third of motors are clearly oversized and operate at below 50% of their nominal load.

However:

- Oversized motors are more expensive.
- Oversized motors are sometimes less efficient than correctly sized motors: motors are at their most effective working point when operating between 30% and 100% of rated load and are built to sustain short periods at 120% of their rated load. Efficiency declines rapidly when loads are below 30%.
- The power factor drops drastically when the motor does not work at full load, which can lead to charges being levied for reactive power.

Knowing that energy costs account for over 97% of the lifecycle costs of a motor, investing in a more expensive but more efficient motor can quickly be very profitable.

However, before deciding whether to replace a motor, it is essential:

- to take the motor's remaining life cycle into consideration.
- to remember that the expense of replacing a motor even if it is clearly oversized, may not be justified if its load is very small or if it is only used infrequently (e.g. less than 800 hours per year see Fig. K17).
- to ensure that the new motor's critical performance characteristics (such as speed) are equivalent to those of the existing motor.

Operation of the motor

Other approaches are also possible to improve the energy efficiency of motors:

- Improving active energy efficiency by simply stopping motors when they no longer need to be running. This method may require improvements to be made in terms of automation, training or monitoring, and operator incentives may have to be offered.

If an operator is not accountable for energy consumption, he/she may well forget to stop a motor at times when it is not required.

- Monitoring and correcting all the components in drive chains, starting with those on the larger motors, which may affect the overall efficiency. This may involve, for example, aligning shafts or couplings as required. An angular offset of 0.6 mm in a coupling can result in a power loss of as much as 8%.

Control of the motor

To ensure the best overall energy efficiency, the motor's control system must be chosen carefully, depending on the motor's application:

- For a constant speed application, motor starters provide cheap, low-energy-consumption solutions. Three kinds of starters can be used, depending on the system's constraints:

- Direct on line starter (contactor)
- Star Delta starter: to limit the inrush current, provided that the load allows a starting torque of 1/3 of nominal torque
- Soft starter: when Star Delta starter is not suitable to perform a limited inrush current function and if soft braking is needed.

Example of constant speed applications: ventilation, water storage pumps, waste water treatment stirring units, conveyors, etc.

K - Energy efficiency in electrical distribution

4 Energy saving opportunities

The method for starting/controlling a motor should always be based on a system-level analysis, considering several factors such as variable speed requirements, overall efficiency and cost, mechanical constraints, reliability, etc.

PB116781.eps



LC1 D65A**

PB116782.eps



LC3 D32A**

PB116783.eps



ATS48**

Fig. K18 Motor starter examples: TeSys D Direct on line contactors, Star Delta starter, Altistart softstarter (Schneider Electric)

■ When the application requires varying the speed, a Variable Speed Drive (VSD) provides a very efficient active solution as it adapts the speed of the motor to limit energy consumption.

It competes favourably with conventional mechanical solutions (valves, dampers and throttles, etc.), used especially in pumps and fans, where their operating principle causes energy to be lost by blocking ducts while motors are operating at full speed.

VSDs also offer improved control as well as reduced noise, transient effects and vibration. Further advantages can be obtained by using these VSDs in conjunction with control devices tailored to meet individual requirements.

As VSDs are costly devices which generate additional energy losses and can be a source of electrical disturbances, their usage should be limited to applications that intrinsically require variable speed or fine control functions.

Example of variable speed applications: hoisting, positioning in machine tools, closed-loop control, centrifugal pumping or ventilation (without throttle) or booster pumps, etc.

K15

DB422952_EN.eps

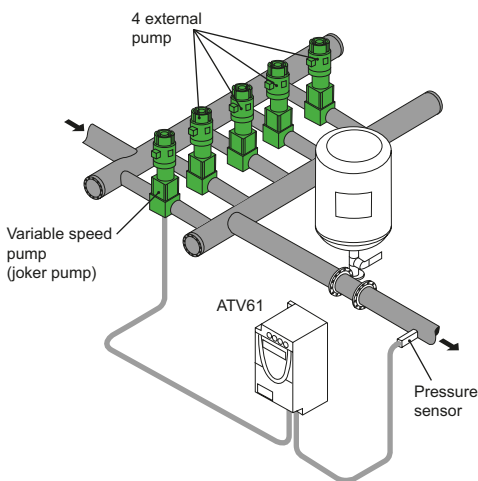


Fig. K20 Example of cascading pumps, which skilfully combine starters and a variable speed drive to offer a flexible but not too expensive solution

PB116784.eps



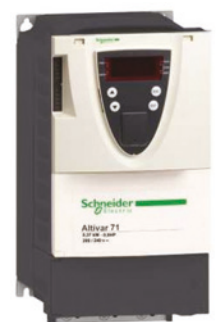
Altivar 12 (≤ 4 kW)

PB116785.eps



Altivar 212 (≤ 75 kW)

PB116786.eps



Altivar 71 (≤ 630 kW)

Fig. K19 Variable Speed Drives of various power ratings (Altivar range, Schneider Electric)

■ To handle loads that change depending on application requirements, starters, VSDs, or a combination of both with an appropriate control strategy (see cascading pumps example Fig. K20) should be considered, in order to provide the most efficient and profitable overall solution.

Example of applications: HVAC for buildings, goods transport, water supply systems, etc.

The method for starting/controlling a motor should always be based on a system-level analysis, considering several factors such as variable speed requirements, overall efficiency and cost, mechanical constraints, reliability, etc.

4 Energy saving opportunities

4.2 Lighting

Lighting can account for over 35% of energy consumption in buildings, depending on the types of activities carried out in them. Lighting control is one of the easiest ways to make substantial energy savings for a relatively small investment and is one of the most common energy saving measures.

Lighting systems for commercial buildings are governed by standards, regulations and building codes. Lighting not only needs to be functional, but must also meet occupational health and safety requirements and be fit for purpose.

In many cases office lighting is excessive and there is considerable scope for making passive energy savings. These can be achieved by replacing inefficient luminaires, by replacing obsolete lights with high-performance/low-consumption alternatives and by installing electronic ballasts. These kinds of approach are especially appropriate in areas where lighting is required constantly or for long periods and savings cannot be achieved by simply switching lights off. The time taken to recoup investments varies from case to case, but many projects require a period of around two years.

Lights and electronic ballasts or LED technology

More efficient lights may be a possibility, depending on the needs, type and age of the lighting system. For example, new fluorescent lights are available, although ballasts also need to be replaced when lights are changed.

New electronic ballast are also available, offering significant energy savings compared to the earlier electromagnetic ballasts. For example, T8 lights with electronic ballasts use between 32% and 40% less electricity than T12 lights fitted with electromagnetic ballasts.

However, electronic ballasts do have a number of points of attention compared with magnetic ballasts:

- Their operating frequency (between 20 and 60 kHz) can introduce high frequency conducted and radiated disturbances, which can interfere with power line communication devices for example. Adequate filters must be incorporated.
- The supply current of standard devices is highly distorted, so that typical disturbances linked to harmonics are present, such as neutral current overload. (See also chapter M). Low harmonic emission devices are now available, which keep harmonic distortion to less than 20 percent of fundamental current, or even 5% for more sensitive facilities (hospitals, sensitive manufacturing environments ...).

The LED technology, introduced only a few years ago, offers significant prospects for progress, especially for smart control. LED are considered as the sustainable alternative solution to achieve energy savings objectives in the lighting sector. This is the first lighting technology suitable for all fields (residential, service sector buildings, infrastructure ...) providing great energy efficiency and smart management capability.

Other types of lighting may be more appropriate, depending on the conditions involved. An assessment of lighting needs will focus on evaluating the activities performed and the required levels of illumination and colour rendering. Many existing lighting systems were designed to provide more light than required. Designing a new system to closely fit lighting needs makes it easier to calculate and ultimately achieve savings.

Apart from the issue of savings, and without forgetting the importance of complying with the relevant standards and regulations, there are other advantages associated with retrofitting lighting systems. These include lower maintenance costs, the chance to make adjustments based on needs (office areas, "walk-through" areas etc.), greater visual comfort (by eradicating the frequency beat and flickering typically associated with migraine and eye strain) and improved colour rendering.

Reflectors

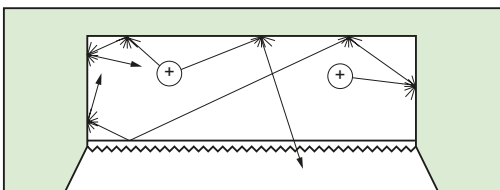
A less common passive energy efficiency measure, but one which is worth considering in tandem with the use of lights fitted with ballasts, is to replace the reflectors diverting light to areas where it is needed. Advances in materials and design have resulted in better quality reflectors which can be fitted to existing lights. These reflectors intensify useful light, so that fewer lights may be required in some cases. Energy can be saved without having to compromise on lighting quality.

New, high-performance reflectors offer a spectral efficiency of over 90% (see Fig. K21). This means:

- Two lights can be replaced by a single light, with potential savings of 50% or more in terms of the energy costs associated with lighting.
- Existing luminaires can be retrofitted by installing mirror-type reflectors without having to adjust the distance between them. This has the advantage of simplifying the retrofitting process and reducing the work involved, with minimal changes made to the existing ceiling design.

K16

D9422655_EN.eps



Above: Around 70% of a fluorescent tube's light is directed sideways and upwards.

Below: The new silver surfaces are designed to reflect the maximum amount of light downwards.

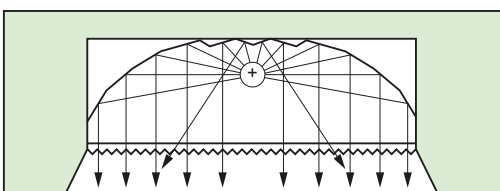


Fig. K21 Illustration of the general operating principle for high-performance reflectors

4 Energy saving opportunities

Lighting control

The passive energy saving measures described above leave further scope for making savings. The aim of lighting control programmes is to give users the required levels of convenience and flexibility, whilst supporting active energy savings and cost reduction by switching lights off as soon as they are no longer needed. There are a number of technologies available with various degrees of sophistication, although the time taken to recoup investments is generally short at six to twelve months. A multitude of different devices are currently available too (see Fig. K22).



Fig. K22 A selection of lighting control devices: timers, light sensors, movement sensors

- Timers to turn off lights after a certain period has passed. These are best used in areas where the typical time spent or period of activity is clearly defined (such as corridors).
- Occupancy/movement sensors to turn off lights when no movement has been detected for a certain period. These are particularly well suited to areas where the time spent or period of activity cannot be accurately predicted (storerooms, stairwells, etc.).
- Photoelectric cells/daylight harvesting sensors to control lights near windows. When sufficient daylight is available, lights are turned off or switched to night-light mode.
- Programmable clocks to switch lights on and off at predetermined times (shop fronts, office lights at nights and weekends)
- Dimmable lights to provide a low level of illumination (night light) at off-peak periods (e.g. a car park requiring full illumination until midnight, but where lower levels will suffice between midnight and dawn)
- Voltage regulators, ballasts or special electronic devices to optimise energy consumption for lights (fluorescent tubes, high-pressure sodium lights, etc.)
- Wireless remote control devices for simple and economical retrofitting of existing applications

These various technologies may be combined and can also be used to create a specific effect or atmosphere. For example, programmable lighting panels in meeting areas (for board meetings, presentations, conferences, etc.) have a number of different light settings which can be changed at the flick of a switch.

4 Energy saving opportunities

Centralised lighting management

Some of the lighting control systems currently available, such as those based on the KNX protocol, have the additional advantage of supporting integration into building management systems (see Fig. K23).

They offer greater flexibility of management and centralised monitoring, and provide more scope for energy savings by enabling lighting controls to be integrated into other systems (e.g. air conditioning). Certain systems enable energy savings of 30%, although efficiency levels will depend on the application involved and this must be chosen with some care.

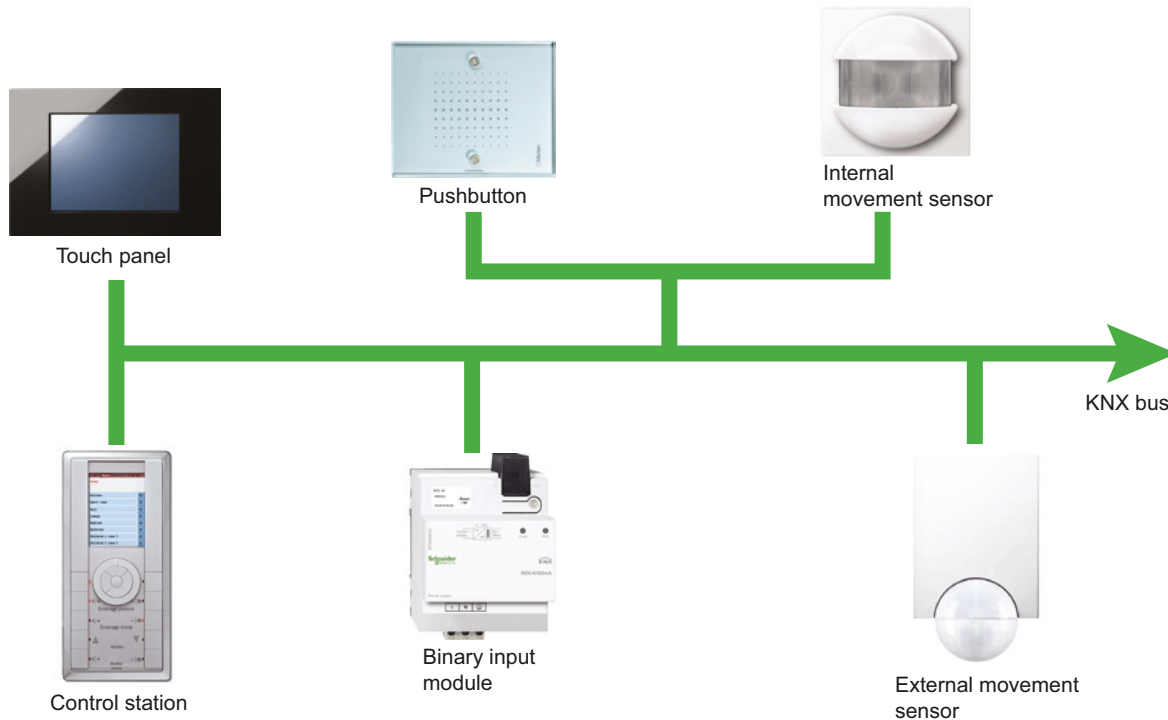


Fig. K23 An example of links established using Schneider Electric's KNX system

If this type of system is to produce results, the design and implementation stage must begin with an audit of energy consumption and a study of the lighting system with a view to devising the best lighting solution and identifying potential reductions in terms of both costs and energy consumption. As far as this kind of technology is concerned, Schneider Electric also has solutions for offices as well as exterior lighting, car parking facilities, parks and landscaped gardens.

4.3 Power factor correction and harmonic filtering

■ If the energy distribution company imposes penalties for reactive power consumption, improving power factor correction is a typically passive energy saving measure. It takes immediate effect after implementation and does not require any changes to procedures or staff behaviour. The investment involved can be recouped in less than a year.

See **Chapter L** for further details.

■ Many types of equipment (variable speed drives, electronic ballasts, etc.) and computers generate harmonics within their line supply. The effects produced can sometimes be significant heat and vibration potentially reducing the efficiency and service life of such equipment as capacitor banks used for power factor correction. Harmonic filtering is another typical passive energy saving measure to consider.

See **Chapter M** for further details.

4 Energy saving opportunities

4.4 Load management

As part of their drive towards synchronizing the consumption and production of electrical energy over the long term, energy distribution companies tailor their rates to encourage consumers to reduce their requirements during peak periods.

A number of different strategies are possible, depending on consumption levels and operating requirements: restricting demand (see Fig. K24), avoiding peak periods, load scheduling or even generating additional energy on site. This is also known as «demand response».

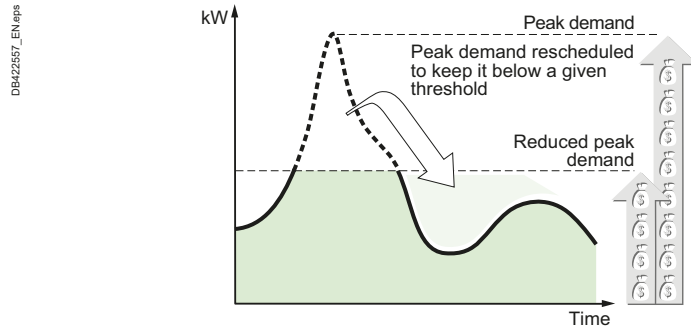


Fig. K24 An example of a load-management strategy

■ Demand restriction

Energy distribution companies can use this solution in supply contracts containing optional or emergency (involving compulsory limits) restrictive clauses whose application is determined by the consumer (based on special rates). This management policy is typically used during the hottest or coldest months of the year when companies and private customers have very high requirements for ventilation, air conditioning and heating, and when electricity consumption exceeds normal demand considerably. Reducing consumption in this way can prove problematic in residential and service sector environments, as they may considerably inconvenience building occupants. Customers from industry may show more of an interest in this type of scheme and could benefit from contracts reducing unit costs by up to 30% if they have a high number of non-essential loads.

■ Peak demand avoidance

This method involves moving consumption peaks in line with the different rates available. The idea is to reduce bills, even if overall consumption remains the same

■ Load scheduling

This management strategy is an option for companies able to benefit from lower rates by scheduling consumption for all their processes where time of day is neither important nor critical.

■ Additional energy generation on site

The use of generating sets to supply energy improves operational flexibility by providing the energy needed to continue normal operations during periods of peak or restricted demand. An automated control system can be configured to manage this energy production in line with needs and the rates applicable at any given time. When energy supplied from outside becomes more expensive than energy generated internally, the control system automatically switches between the two.

4 Energy saving opportunities

4.5 Communication and information systems

Information systems

No Energy Efficiency is possible without communication.

But whether it relates to measurements, operating statuses or rate bases, raw data can only be useful when converted into usable information and distributed on a need-to-know basis to all those involved in energy efficiency with a view to improving the expertise of all participants in the energy management process.

Data must also be explained, as people can only develop the management and intervention skills integral to any effective energy saving policy if they fully understand the issues involved. Data distribution must produce actions, and these actions will have to continue if energy efficiency is to be sustained (see Fig. K25). However, this cycle of operations requires an effective communication network to be in place.

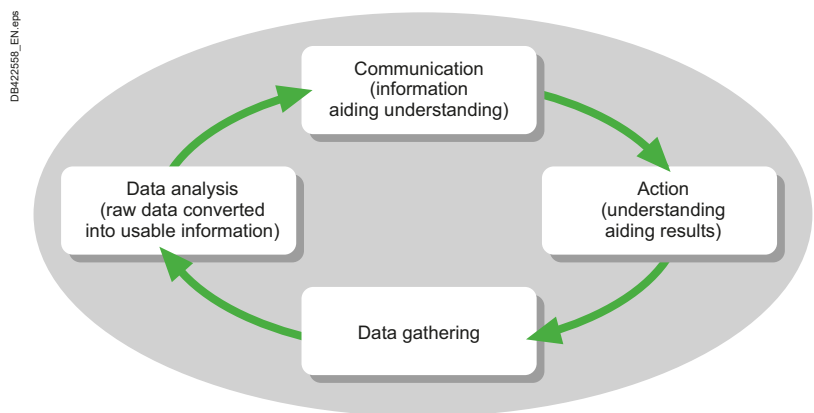


Fig. K25 Operating cycle for data essential to energy efficiency

K20

The information system can then be used on a daily basis by the operators at the various locations where electricity is consumed (for industrial processes, lighting, air conditioning, and so on) to achieve the energy efficiency objectives specified by company management. It can also ensure these same locations make a positive contribution to company operations (in terms of product volumes, conditions for supermarket shoppers, temperatures in cold rooms, etc.).

Monitoring systems

■ For quick audits which can be performed on an ongoing basis.

Encouraging familiarity with data and distributing it can help keep everything up to date, but electrical networks develop rapidly and are permanently raising questions about their ability to cope with such new developments.

With this in mind, a system for monitoring the transfer and consumption of energy is able to provide all the information needed to carry out a full audit of the site. As well as electricity, this audit would cover water, air, gas and steam.

Measurements, comparative analyses and standardised energy consumption data can be used to determine the efficiency of processes and industrial installations.

■ For rapid, informed decision making

Suitable action plans can be implemented. These include control and automation systems for lighting and buildings, variable speed drives, process automation, etc. Recording information on effective equipment use makes it possible to determine accurately the available capacity on the network or a transformer and to establish how and when maintenance work should be performed (ensuring measures are taken neither too soon nor too late).

Communication networks

Information and monitoring systems are synonymous with both intranet and Internet communication networks, with exchanges taking place within computer architectures designed on a user-specific basis.

4 Energy saving opportunities

■ Intranet

For the most part, data exchange in the industrial sector uses Web technologies permanently installed on the company's communications network, typically an intranet network for the sole use of the operator.

Concerning data exchange between components connected via a physical transmission link, the Modbus protocol is very widely used. Connection is possible with metering and protection devices in electrical networks. Initially created by Schneider Electric, it is very popular also in the building sector and considered as a standard protocol.

For carrying large amount of data between electrical distribution systems, the latest technology which is now introduced is Ethernet. It is strongly promoted for simplicity and performance. It is the most adapted media for either local display or distant servers.

In practice, electrical data is recorded on industrial Web servers installed in panel boards. The popular TCP/IP standard protocol is used for transmitting this data in order to reduce the ongoing maintenance costs associated with any computer network. This principle is well adapted to communicate data associated with promoting energy efficiency. No additional software is needed – a PC with an Internet browser is all that is required.

As such, all energy efficiency data is recorded and can be communicated in the usual manner via intranet networks, GSM/GPRS, wifi, etc...

For simplicity and consistency, measurement devices and communication interfaces are advantageously embedded in the distribution panel boards. **See 4.6: Smart panels.**

■ Internet

Remote monitoring and control improve data availability and accessibility, whilst offering greater flexibility in terms of servicing. **Fig. K26** shows a diagram of this type of installation. Connection to a server and a standard Web browser makes it much easier to use data and export it to Microsoft Excel™ spreadsheets for the purpose of tracing power curves in real time.

Now, Ethernet technology allows easy connection of panel boards to the Internet, with compatibility with the rapidly developing Smart Grid facilities.

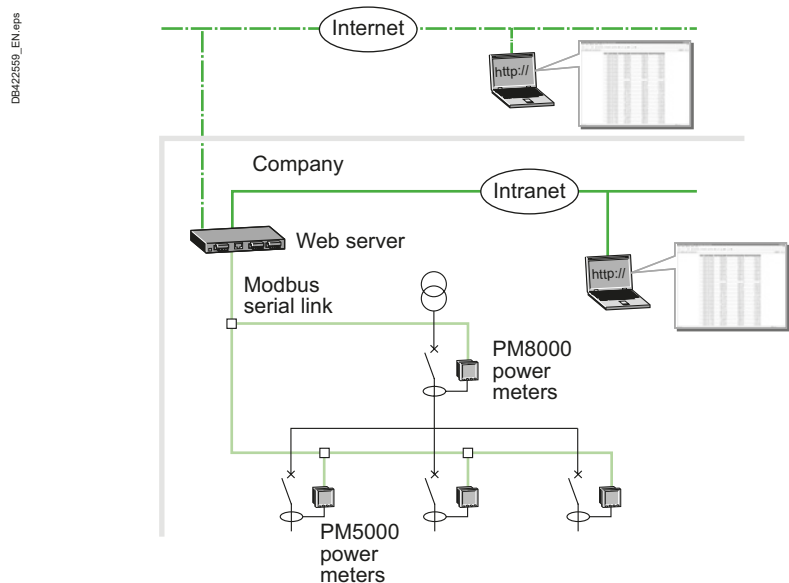


Fig. K26 Example of an intranet information network protected by a server (EGX300 – Schneider Electric) and monitored from the Internet network

■ Architectures

Historically and for many years, monitoring and control systems were centralised and based on SCADA automation systems (Supervisory Control And Data Acquisition).

These days, a distinction is made between three architecture levels (see **Fig. K27** on the next page).

□ Level 1 architecture

Thanks to the new capabilities associated with Web technology, recent times have witnessed the development of a new concept for intelligent equipment. This equipment can be used at a basic level within the range of monitoring systems, offering access to information on electricity throughout the site. Internet access can also be arranged for all services outside the site.

4 Energy saving opportunities

□ Level 2 architecture

This system has been specifically designed for electricians and adapted to meet the demands of electrical networks.

This architecture is based on a centralised monitoring system designed to satisfy all the monitoring requirements for the electrical network. As might be expected, installation and maintenance work requires less expertise than for Level 3, since all the electrical distribution devices are already contained in a specialised library. In addition, acquisition costs can be kept to a minimum, as there are few requirements in terms of system integration.

□ Level 3 architecture

Investment in this type of system is usually restricted to top-of-the-range facilities consuming large amounts of energy or using equipment which is highly sensitive to variations in energy quality and has high demands in terms of electricity availability. To ensure these high demands for availability are met, the system often requires responsibility to be taken for installation components as soon as the first fault occurs. This should be done in a transparent manner (any impact should be clear). In view of the substantial front-end costs, the expertise required to implement the system correctly and the update costs generated as the network develops, potential investors may be deterred and they may require highly detailed prior analyses to be conducted.

Level 2 and Level 3 can be used side by side at certain sites.

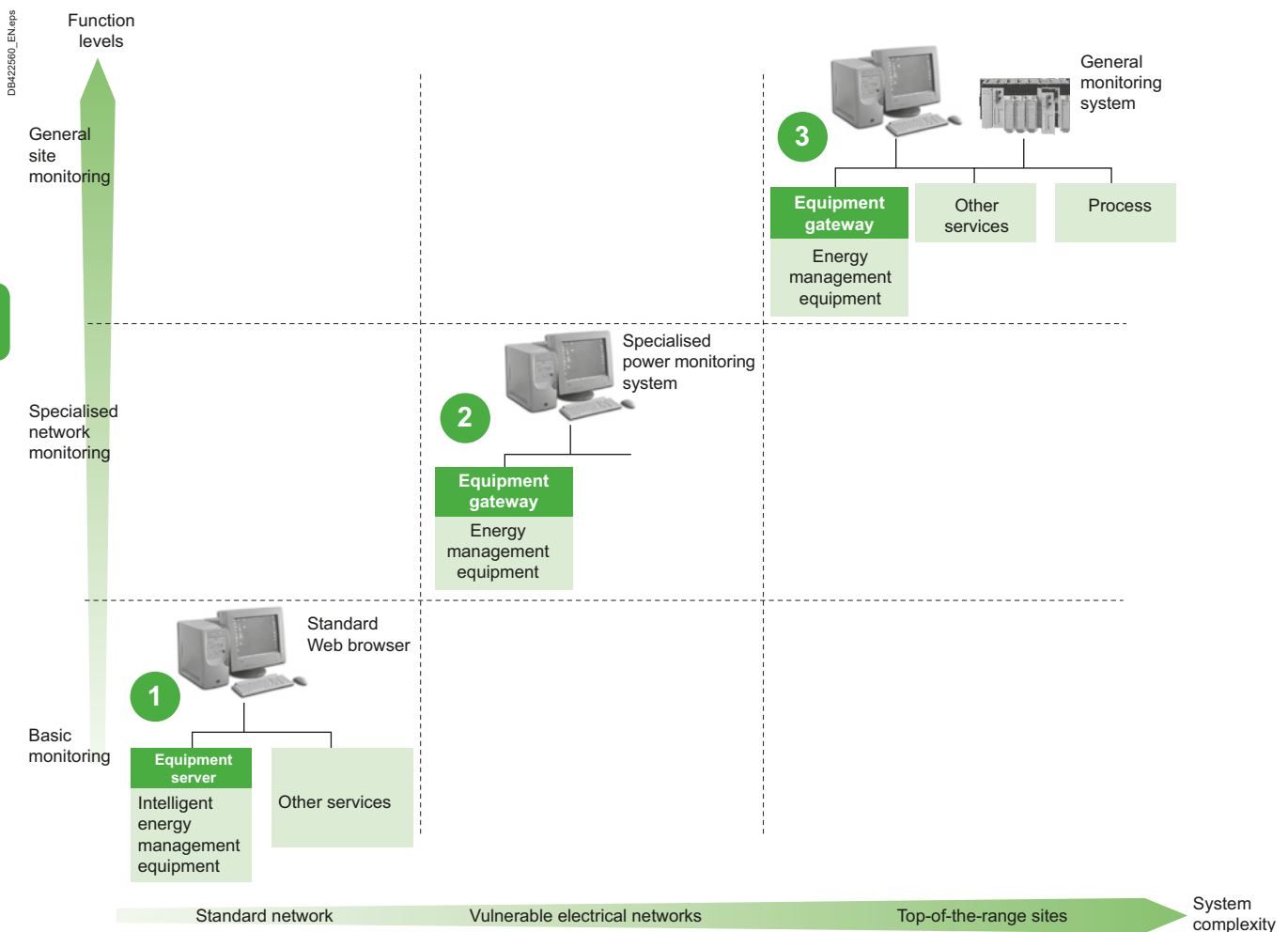


Fig. K27 Layout of a monitoring system

4 Energy saving opportunities

4.6 Smart panels

Smart Panels are distribution switchboards which include the 3 key functions:

- Measure, with embedded and stand-alone metering and control capabilities,
- Connect, with integrated communication interfaces, ready to connect the electrical distribution system to energy management platforms,
- Save, i.e. provide Energy Efficiency benefits, through real-time monitoring and control, and access to on-line services.

With embedded metering devices, Smart Panels are the natural source of data within the electrical installation. Information can be made available on local display, or sent via communication network.

Interface devices are implemented so that communication is made simple and easy to install. The most advanced and efficient technologies are used:

- Modbus: for transmission of information inside switchboards, between components,
- Ethernet cable or wifi: inside buildings, connecting switchboard with computers,
- Ethernet on DSL/GPRS: connecting the electrical distribution system to on-line services.

PB116792.eps

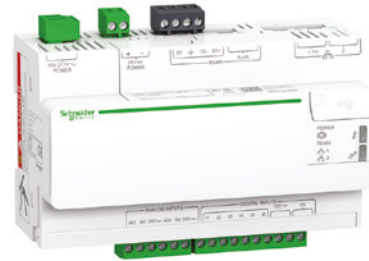


Fig. K28 Example of communication device developed for smart panels (Com'X 200 energy data logger, Schneider Electric)

How Smart Panels contribute to Energy Efficiency?

Smart Panels are designed to monitor electricity in the installation right at the sources. This is the best way to know how energy is used. They are adapted to a large range of power: from final distribution, up to the main distribution board. They offer large possibilities of visualization, from local, up to cloud based integrated solution.

They provide on-site real time monitoring and control. The most essential information can be displayed locally: power, energy consumption, status of equipment, alarms... Control of switchgear is also possible: open, close, reset of protection devices...

Key data and functions are provided on local screen, on-site computer, remote control room or cloud-hosted platform:

- Detect demand peaks or abnormal energy usage,
- Plan long term energy usage,
- Provide trends on energy consumption, making savings possible,
- Provide information for corrective, preventive or predictive maintenance.

Information is made available on PC for the site manager using web pages accessible with standard browser. Access is also given to external experts for analysis and optimization.

4 Energy saving opportunities

Examples of architectures with Smart Panels

Systems for monitoring and energy control are physically very similar and overlap with the electrical distribution architecture whose layout they often replicate.

The arrangements shown in Fig. K29 to Fig. K31 represent possible examples and reflect the requirements typically associated with the distribution involved (in terms of feeder numbers, the amount and quality of energy required, digital networks, management mode, etc.). They help to visualize and explain all the various services which can be used to promote energy efficiency.

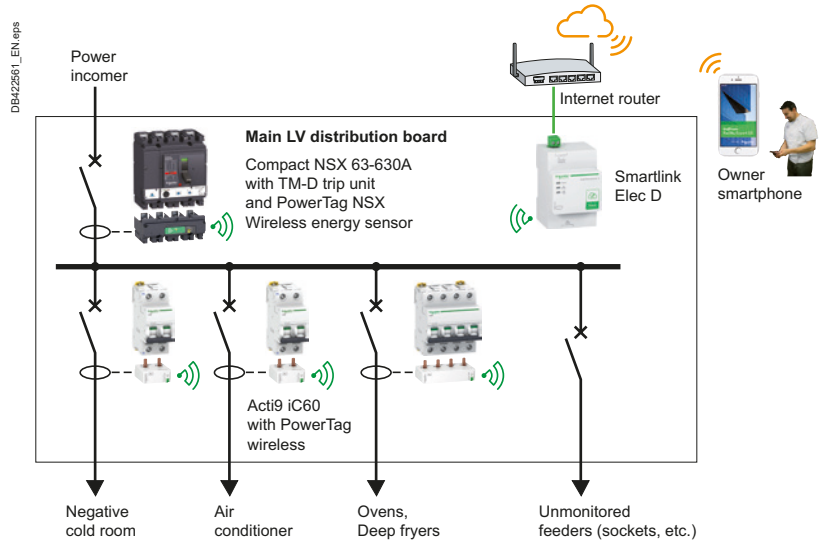


Fig. K29 Example of monitoring architecture for a small site with sub-metering and alarming on selected circuits, using wireless Powertag energy sensors

K24

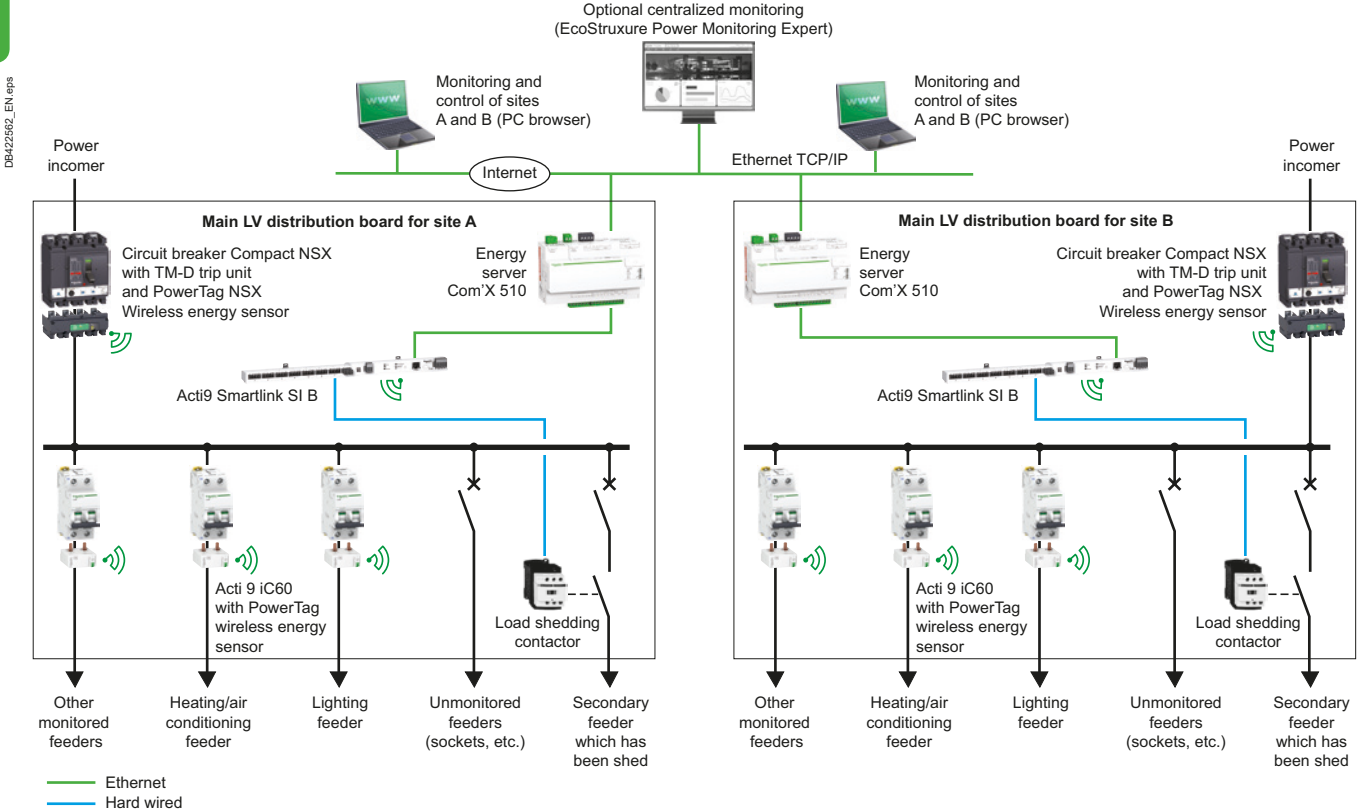
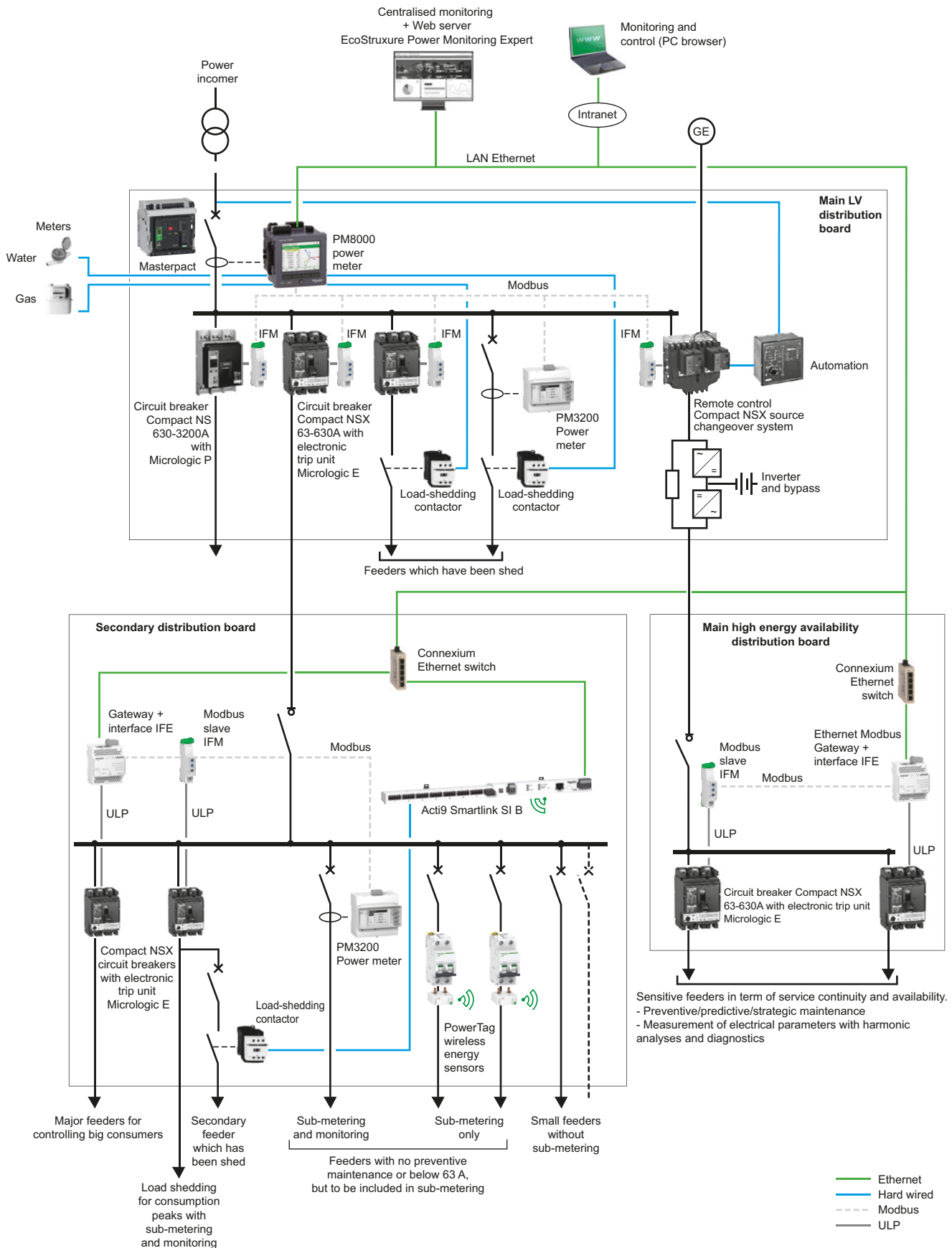


Fig. K30 Example of monitoring and control architecture for a company with several small sites

K - Energy efficiency in electrical distribution

4 Energy saving opportunities

DB42584_EN_eaps



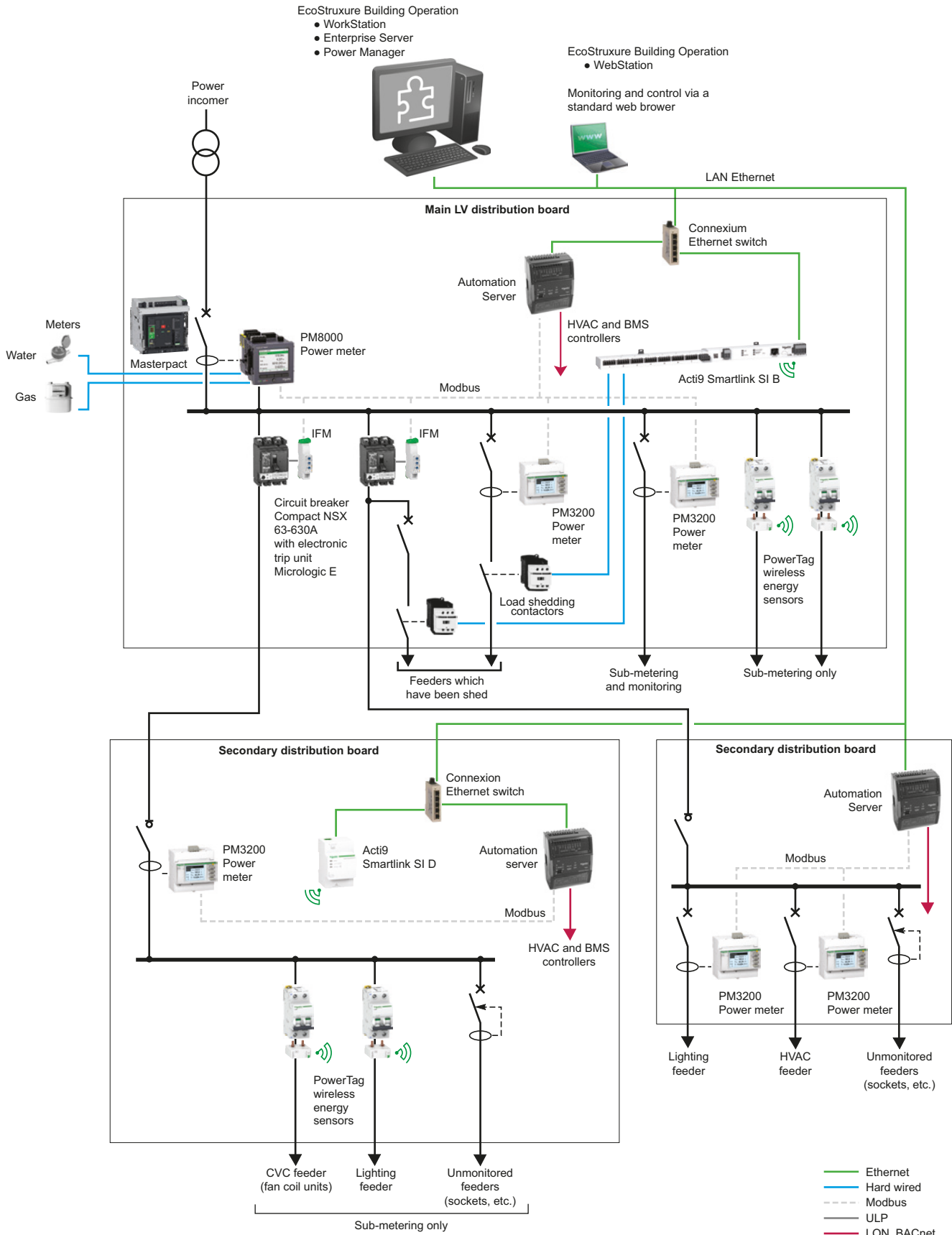
K25

Fig. K31 Example of monitoring and control architecture for a large, sensitive industrial site

K - Energy efficiency in electrical distribution

4 Energy saving opportunities

DB422665_EN.eps



K26

Fig. K32 Architecture for a large commercial site

4 Energy saving opportunities

In addition, these diagrams make it clear that the choice of components is determined by the choice of architecture (for example, the sensors must be compatible with the digital bus). The reverse can also happen, however, if a technico-economic assessment of components installation costs and expected results shows that a different architecture is more cost-effective. In fact, the cost (in terms of purchase and installation) of these components, which sometimes have the same name but different characteristics, may vary widely and produce very variable results:

- A metering device can measure one or more parameters with or without using calculations (energy, power, cos φ).
- Replacing a standard circuit breaker with a circuit breaker containing an electronic control unit can provide a great deal of information on a digital bus (effective and instantaneous measurements of currents, phase-to-neutral and phase-to-phase voltages, imbalances of phase currents and phase-to-phase voltages, frequency, total or phase-specific active and reactive power, etc.).

When designing these systems, therefore, it is very important to define objectives for energy efficiency and be familiar with all the technological solutions, including their respective advantages, disadvantages and any restrictions affecting their application (see Fig. K33).

To cover all the various scenarios, it may be necessary to search through various hardware catalogues or simply consult a manufacturer offering a wide range of electrical distribution equipment and information systems. Certain manufacturers, including Schneider Electric, offer advisory and research services to assist those looking to select and implement all these various pieces of equipment.

	Energy savings	Cost optimisation	Availability and reliability
Variable speed drives	•••	•	•
High-performance motors and transformers	•••		
Supply for MV motors	•••		
Power factor correction	•	•••	
Harmonics management	•	••	•
Circuit configuration			•••
Auxiliary generators		••	•••
Outage-free supply devices (see page N11)			•••
Soft starting	•	•	•••
iMCC		••	••
Architecture based on intelligent equipment Level 1	••	•	
Specialised, centralised architecture for electricians Level 2	•••	••	•
General/conventional, centralised architecture Level 3	•	••	•••

Fig. K33 Solutions chart

K27

5 How to evaluate energy savings

One of the main obstacles facing those interested in devising and implementing energy efficiency projects is the lack of reliable financial data to provide a convincing business case. The higher the investment, the greater the need for credible proof of the proposed advantages. As such, it is very important to have reliable methods for quantifying results when investing in energy efficiency.

The information provided in this chapter is taken from Volume 1 of the IPMVP guide published by EVO (see www.evo-world.org).

5.1 IPMVP and EVO procedures

To cater for this need, EVO (Efficiency Evaluation Organization), the body responsible for evaluating performance, has published the IPMVP (International Performance Measurement and Verification Protocol). This guide describes the procedures used when measuring, calculating and documenting the savings achieved as a result of various energy efficiency projects. So far, EVO has published three volumes of the IPMVP, the first of which, "Concepts and Options for Determining Energy and Water Savings", outlines methods of varying cost and accuracy for establishing total savings made or those made solely in terms of energy efficiency. Schneider Electric uses this document when putting together energy efficiency projects.

IPMVP principles and features

Before implementing the energy efficiency solution, a study based on IPMVP principles should be carried out over a specific period in order to define the relationship which exists between energy use and operating conditions. During this period, reference values are defined by taking direct measurements or by simply studying the energy bills for the site.

After implementation, this reference data is used to estimate the amount of energy, referred to as "adjusted-baseline energy", which would have been consumed had the solution not been implemented. The energy saved is the difference between this "adjusted-baseline energy" and the energy which was actually measured.

If a verification and measurement plan is put together as part of an IPMVP programme, it needs to be:

■ Accurate

Verification and measurement reports should be as accurate as possible for the budget available. The costs involved in verification and measurement should normally be comparatively low in terms of the anticipated savings.

■ Complete

The study of energy savings should reflect the full impact of the project.

■ Conservative

Where doubts exist in terms of results, verification and measurement procedures should underestimate the savings being considered.

■ Consistent

The energy efficiency report should cover the following factors in a consistent manner:

- The various types of energy efficiency project
- The various types of experts involved in each project
- The various periods involved in each project
- The energy efficiency projects and the new energy supply projects

■ Relevant

Identifying savings must involve measuring performance parameters which are relevant or less well known, with estimates being made for less critical or more predictable parameters.

■ Transparent

All the measurements involved in the verification and measurement plan must be presented in a clear and detailed manner.

5 How to evaluate energy savings

IPMVP options

Four study levels or “options” have been defined in line with the objectives assigned to this energy efficiency approach:

- Retrofitting isolation systems with measurements of all key parameters = Option A
- Retrofitting isolation systems with measurements of all parameters = Option B
- Whole facility = Option C
- Calibrated simulation = Option D

Fig. K34 sets out these options in a table. The algorithm in Fig. K35 shows the process of selecting options for a project.

	Option A	Option B	Option C	Option D
Financial objective	Retrofit isolation systems: key parameter measurement	Retrofit isolation systems: all parameter measurement	Whole facility	Calibrated simulation
Description	Savings are calculated using data from the main performance parameter(s) defining energy consumption for the system involved in the energy efficiency solution. Estimates are used for parameters not chosen for actual measurements.	Savings are calculated using actual energy consumption data for the system involved in the energy efficiency solution.	Savings are established using actual energy consumption data for the facility or a section of it. Data for energy use within the facility as a whole is gathered on an ongoing basis throughout the reporting period.	Savings are established by simulating energy consumption for the facility or a section of it. There must be evidence that the simulation procedures are providing an adequate model of the facility's actual energy performance.
Savings calculation	An engineering calculation is performed for the energy consumed during the baseline period and the reporting period based on: <ul style="list-style-type: none"> ■ Ongoing or short-term measurements of the main performance parameter(s), ■ And estimated values. 	Ongoing or short-term measurements of the energy consumed during the baseline period and the reporting period	An analysis of data on the energy consumed during the baseline period and the reporting period for the whole facility. Routine adjustments are required, using techniques such as simple comparison or regression analysis.	Energy use simulation, calibrated with hourly or monthly utility billing data
When to use option	On the one hand, the results obtained using this option are rather equivocal given that some parameters are estimated. Having said this, it is a much less expensive method than Option B.	Option B is more expensive than Option A, as all parameters are measured. It is the better option, however, for customers who require a high level of accuracy.	For complex energy management programmes affecting many systems within a facility, Option C supports savings and helps to simplify the processes involved.	Option D is only used when there is no baseline data available. This may be the case where a site did not have a meter before the solution was implemented or where acquiring baseline data would involve too much time or expense.

Fig. K34 Summary of IPMVP options

5 How to evaluate energy savings

K30

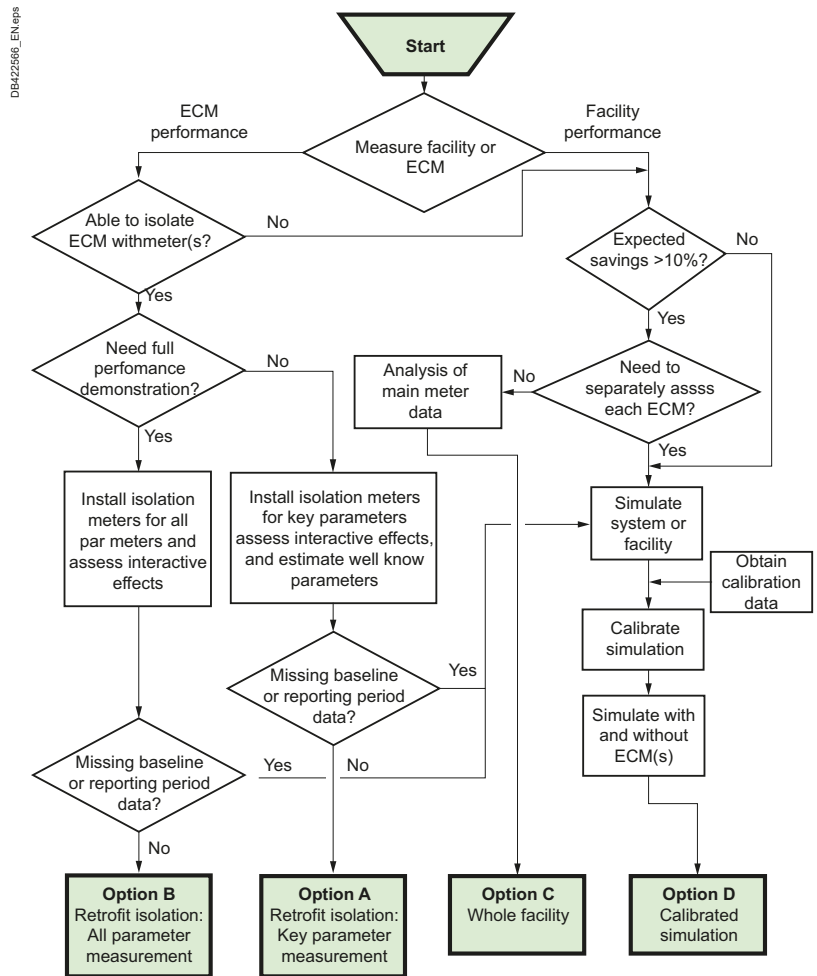


Fig. K35 Process for selecting an IPMVP option for a project

5.2. Achieving sustainable performance

Once the energy audits have been completed, the energy saving measures have been implemented and the savings have been quantified, it is essential to follow the procedures below to ensure performance can be sustained over time. Performance tends to deteriorate if there is no continuous improvement cycle in place (see Fig. K36).

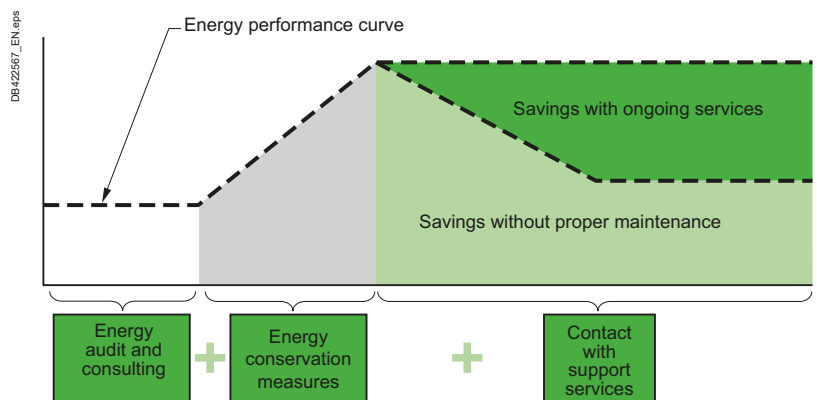


Fig. K36 Ensuring performance is sustainable over time

5 How to evaluate energy savings

A continuous improvement cycle will only work if there is an energy monitoring system in place, and this system is used effectively and maintained. The system supports a continuous and proactive analysis of energy use at the site, and informs recommendations for improving the electrical distribution system.

Support services, either on site or at a remote location (accessible via telephone, e-mail, VPN (Virtual Private Network) or any other type of long-distance connection), are often required to ensure optimal performance for this type of system and the best use of the collected data. Thanks to their contribution in terms of experience and availability, these services also complement the operator's in-house services. The services available may include:

- Monitoring the performance of measuring devices
- Updating and adapting software
- Managing databases (e.g. archives)
- Continuously adapting the monitoring system in line with changing control requirements.

K - Energy efficiency in electrical distribution

K32

1	Power factor and Reactive power	L2
	1.1 Definition of power factor.....	L2
	1.2 Definition of reactive power.....	L2
	1.3 The nature of reactive power.....	L4
	1.4 Reactive power of capacitors.....	L4
	1.5 Equipment and appliances requiring reactive energy.....	L4
	1.6 Practical values of power factor.....	L5
2	Why to improve the power factor?	L6
	2.1 Reduction in the cost of electricity.....	L6
	2.2 Technical/economic optimization.....	L6
3	How to improve the power factor?	L8
	3.1 Theoretical principles.....	L8
	3.2 By using what equipment?.....	L8
	3.3 The choice between a fixed or automatically-regulated bank of capacitors.....	L10
4	Where to install power factor correction capacitors?	L11
	4.1 Global compensation.....	L11
	4.2 Compensation by sector.....	L11
	4.3 Individual compensation.....	L12
5	How to determine the optimum level of compensation?	L13
	5.1 General method.....	L13
	5.2 Simplified method.....	L13
	5.3 Method based on the avoidance of tariff penalties.....	L15
	5.4 Method based on reduction of declared maximum apparent power (kVA).....	L15
6	Compensation at the terminals of a transformer	L16
	6.1 Compensation to increase the available active power output.....	L16
	6.2 Compensation of reactive energy absorbed by the transformer.....	L17
7	Power factor correction of induction motors	L19
	7.1 Connection of a capacitor bank and protection settings.....	L19
	7.2 How self-excitation of an induction motor can be avoided.....	L20
8	Example of an installation before and after power-factor correction	L21
9	The effects of harmonics	L22
	9.1 Problems arising from power-system harmonics.....	L22
	9.2 Risk of resonance.....	L23
	9.3 Possible solutions.....	L24
10	Implementation of capacitor banks	L26
	10.1 Capacitor elements.....	L26
	10.2 Choice of protection, control devices and connecting cables.....	L27

1 Power factor and Reactive power

1.1 Definition of power factor

The Power Factor is an indicator of the quality of design and management of an electrical installation. It relies on two very basic notions: active and apparent power.

The **active power P (kW)** is the real power transmitted to loads such as motors, lamps, heaters, and computers. The electrical active power is transformed into mechanical power, heat or light.

In a circuit where the applied r.m.s. voltage is V_{rms} and the circulating r.m.s. current is I_{rms} , the **apparent power S (kVA)** is the product: $V_{rms} \times I_{rms}$.

The apparent power is the basis for electrical equipment rating.

The **Power Factor λ** is the ratio of the active power P (kW) to the apparent power S (kVA):

$$\lambda = \frac{P(kW)}{S(kVA)}$$

The load may be a single power-consuming item, or a number of items (for example an entire installation).

The value of power factor will range from 0 to 1.

1.2 Definition of reactive power

For most electrical loads like motors, the current I is lagging behind the voltage V by an angle ϕ .

If currents and voltages are perfectly sinusoidal signals, a vector diagram can be used for representation.

In this vector diagram, the current vector can be split into two components: one in phase with the voltage vector (component I_a), one in quadrature (lagging by 90 degrees) with the voltage vector (component I_r). (See Fig. L1)

I_a is called the **"active"** component of the current.

I_r is called the **"reactive"** component of the current.

The previous diagram drawn up for currents also applies to powers, by multiplying each current by the common voltage V.

We thus define:

Apparent power: $S = V \times I$ (kVA)

Active power: $P = V \times I_a$ (kW)

Reactive power: $Q = V \times I_r$ (kvar)

In this diagram, we can see that:

■ Power Factor: $P/S = \cos \phi$

This formula is applicable for sinusoidal voltage and current. This is why the Power Factor is then designated as "Displacement Power Factor".

■ $Q/S = \sin \phi$

■ $Q/P = \tan \phi$

A simple formula is obtained, linking apparent, active and reactive power: $S^2 = P^2 + Q^2$

A power factor close to unity means that the apparent power S is minimal.

This means that the electrical equipment rating is minimal for the transmission of a given active power P to the load. The reactive power is then small compared with the active power.

A low value of power factor indicates the opposite condition.

Useful formulae (for balanced and near-balanced loads on 4-wire systems):

■ **Active power P** (in kW)

□ Single phase (1 phase and neutral): $P = V.I.\cos \phi$

□ Single phase (phase to phase): $P = U.I.\cos \phi$

□ Three phase (3 wires or 3 wires + neutral): $P = \sqrt{3}.U.I.\cos \phi$

■ **Reactive power Q** (in kvar)

□ Single phase (1 phase and neutral): $Q = V.I.\sin \phi$

□ Single phase (phase to phase): $Q = U.I.\sin \phi$

□ Three phase (3 wires or 3 wires + neutral): $Q = \sqrt{3}.U.I.\sin \phi$

DB422580.eps

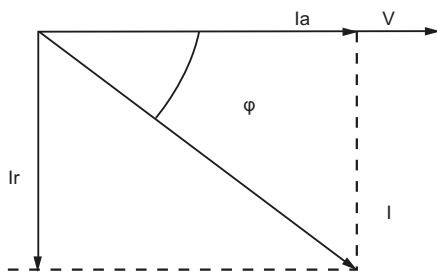


Fig. L1 Current vector diagram

DB422581.eps

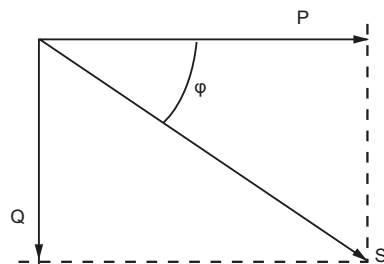


Fig. L2 Power vector diagram

L2

1 Power factor and Reactive power

■ **Apparent power S** (in kVA)

- Single phase (1 phase and neutral): $S = V.I$
- Single phase (phase to phase): $S = U.I$
- Three phase (3 wires or 3 wires + neutral): $S = \sqrt{3}.U.I$

where:

V = Voltage between phase and neutral

U = Voltage between phases

I = Line current

φ = Phase angle between vectors V and I.

An example of power calculations (see Fig. L4)

Type of circuit	Apparent power S (kVA)	Active power P (kW)	Reactive power Q (kvar)
Single-phase (phase and neutral)	$S = VI$	$P = VI \cos \varphi$	$Q = VI \sin \varphi$
Single-phase (phase to phase)	$S = UI$	$P = UI \cos \varphi$	$Q = UI \sin \varphi$
Example: 5 kW of load $\cos \varphi = 0.5$	10 kVA	5 kW	8.7 kvar
Three phase 3-wires or 3-wires + neutral	$S = \sqrt{3} UI$	$P = \sqrt{3} UI \cos \varphi$	$Q = \sqrt{3} UI \sin \varphi$
Example: Motor $P_n = 51$ kW $\cos \varphi = 0.86$ $\rho = 0.91$ (motor efficiency)	65 kVA	56 kW	33 kvar

Fig. L3 Example in the calculation of active and reactive power

The calculations for the three-phase example above are as follows:

P_n = delivered shaft power = 51 kW

P = active power consumed

$$P = \frac{P_n}{\rho} = \frac{51}{0.91} = 56 \text{ kW}$$

S = apparent power

$$S = \frac{P}{\cos \varphi} = \frac{56}{0.86} = 65 \text{ kVA}$$

So that, on referring to Fig. L16 or using a pocket calculator, the value of $\tan \varphi$ corresponding to a $\cos \varphi$ of 0.86 is found to be 0.59

$Q = P \tan \varphi = 56 \times 0.59 = 33 \text{ kvar}$ (see Fig. L4).

Alternatively

$$Q = \sqrt{S^2 - P^2} = \sqrt{65^2 - 56^2} = 33 \text{ kvar}$$

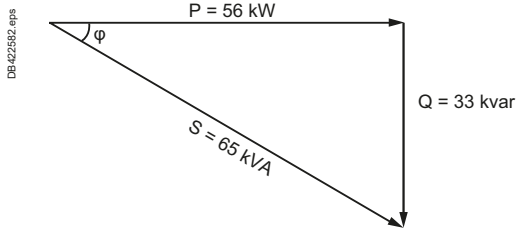


Fig. L4 Calculation power diagram

1 Power factor and Reactive power

DB422583.eps

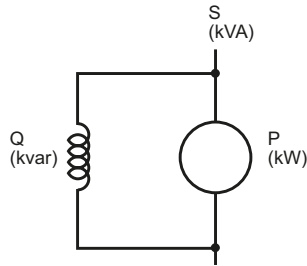


Fig. L5 An electric motor requires active power P and reactive power Q from the power system

1.3 The nature of reactive power

All inductive (i.e. electromagnetic) machines and devices that operate on AC systems convert electrical energy from the power system generators into mechanical work and heat. This energy is measured by kWh meters, and is referred to as “active” energy.

In order to perform this conversion, magnetic fields have to be established in the machines. The magnetic field is created by the circulation of current in coils, which are mainly inductive. The current in these coils is therefore lagging by 90° relative to the voltage, and represent the reactive current absorbed by the machine.

It should be noted that while reactive current does not draw power from the system, it does cause power losses in transmission and distribution systems by heating the conductors.

In practical power systems, load currents are invariably inductive, and impedances of transmission and distribution systems predominantly inductive as well. The combination of inductive current passing through an inductive reactance produces the worst possible conditions of voltage drop (i.e. in direct phase opposition to the system voltage).

For these two reasons (transmission power losses and voltage drop), the Network Operators work for reducing the amount of reactive (inductive) current as much as possible.

1.4 Reactive power of capacitors

The current flowing through capacitors is leading the voltage by 90°.

The corresponding current vector is then in opposition to the current vector of inductive loads. This why capacitors are commonly used in the electrical systems, in order to compensate the reactive power absorbed by inductive loads such as motors.

Inductive-reactive power is conventionally positive (absorbed by an inductive load), while capacitive-reactive power is negative (supplied by a capacitive load).

As reactive-inductive loads and line reactance are responsible for voltage drops, reactive-capacitive currents have the reverse effect on voltage levels and produce voltage-rises in power systems.

1.5 Equipment and appliances requiring reactive energy

All AC equipment and appliances that include electromagnetic devices, or depend on magnetically coupled windings, require some degree of reactive current to create magnetic flux.

The most common items in this class are transformers, reactors, motors and discharge lamps with magnetic ballasts (see Fig. L6).

The proportion of reactive power (kvar) with respect to active power (kW) when a piece of equipment is fully loaded varies according to the item concerned being:

- 65-75% for asynchronous motors (corresponding to a Power Factor 0.8 – 0.85)
- 5-10% for transformers (corresponding to a Power Factor close to 0.995)

L4

DB422584.eps

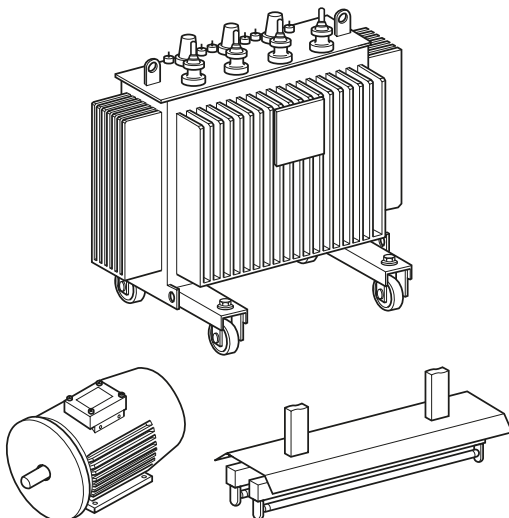


Fig. L6 Power consuming items that also require reactive energy

1 Power factor and Reactive power

1.6 Practical values of power factor

Average power factor values for the most commonly-used equipment and appliances (see Fig. L7).

Equipment and appliances			cos φ	tan φ
Motor	Common induction motor, loaded at	0%	0.17	5.80
		25%	0.55	1.52
		50%	0.73	0.94
		75%	0.80	0.75
		100%	0.85	0.62
Lamps	Incandescent lamps		1.0	0
	Fluorescent lamps (uncompensated)		0.5	1.73
	Fluorescent lamps (compensated)		0.93	0.39
	Discharge lamps		0.4 to 0.6	2.29 to 1.33
Ovens	Ovens using resistance elements		1.0	0
	Induction heating ovens (compensated)		0.85	0.62
	Dielectric type heating ovens		0.85	0.62
Welding	Resistance-type soldering machines		0.8 to 0.9	0.75 to 0.48
	Fixed 1-phase arc-welding set		0.5	1.73
	Arc-welding motor-generating set		0.7 to 0.9	1.02 to 0.48
	Arc-welding transformer-rectifier set		0.7 to 0.9	1.02 to 0.75
Arc furnace			0.8	0.75

Fig. L7 Values of cos φ and tan φ for commonly-used equipment

2 Why to improve the power factor?

Improvement of the power factor of an installation presents several technical and economic advantages, notably in the reduction of electricity bills

2.1 Reduction in the cost of electricity

Good management in the consumption of reactive energy brings economic advantages.

These notes are based on an actual tariff structure commonly applied in Europe, designed to encourage consumers to minimize their consumption of reactive energy.

The installation of power-factor correction equipment on installations permits the consumer to reduce his electricity bill by maintaining the level of reactive-power consumption below a value contractually agreed with the power supply authority. In this particular tariff, reactive energy is billed according to the $\tan \phi$ criterion.

As previously noted:

$$\tan \phi = \frac{Q \text{ (kvar)}}{P \text{ (kW)}}$$

The same ratio applies to energies:

$$\tan \phi = \frac{Q \text{ (kvarh)}}{P \text{ (kWh)}}$$

The power supply authority delivers reactive energy for free:

- If the reactive energy represents less than 40% of the active energy ($\tan \phi < 0.4$) for a maximum period of 16 hours each day (from 06-00 h to 22-00 h) during the most-heavily loaded period (often in winter)

- Without limitation during light-load periods in winter, and in spring and summer. During the periods of limitation, reactive energy consumption exceeding 40% of the active energy (i.e. $\tan \phi > 0.4$) is billed monthly at the current rates. Thus, the quantity of reactive energy billed in these periods will be:

$\text{kvarh (to be billed)} = \text{kWh} (\tan \phi - 0.4)$ where:

- kWh is the active energy consumed during the periods of limitation
- kWh $\tan \phi$ is the total reactive energy during a period of limitation
- 0.4 kWh is the amount of reactive energy delivered for free during a period of limitation

$\tan \phi = 0.4$ corresponds to a power factor of 0.93 so that, if steps are taken to ensure that during the limitation periods the power factor never falls below 0.93, the consumer will have nothing to pay for the reactive power consumed.

Against the financial advantages of reduced billing, the consumer must balance the cost of purchasing, installing and maintaining the power factor correction equipment and controlling switchgear, automatic control equipment (where stepped levels of compensation are required) together with the additional kWh consumed by the losses of the equipment, etc. It may be found that it is more economic to provide partial compensation only, and that paying for some of the reactive energy consumed is less expensive than providing 100% compensation.

The question of power-factor correction is a matter of optimization, except in very simple cases.

2.2 Technical/economic optimization

A high power factor allows the optimization of the components of an installation. Overating of certain equipment can be avoided, but to achieve the best results, the correction should be effected as close to the individual inductive items as possible.

Reduction of cable size

Fig. L8 shows the required increase in the size of cables as the power factor is reduced from unity to 0.4, for the same active power transmitted.

Multiplying factor for the cross-sectional area of the cable core(s)	1	1.25	1.67	2.5
$\cos \phi$	1	0.8	0.6	0.4

Fig. L8 Multiplying factor for cable size as a function of $\cos \phi$

Power factor improvement allows the use of smaller transformers, switchgear and cables, etc. as well as reducing power losses and voltage drop in an installation

2 Why to improve the power factor?

Reduction of losses (P, kW) in cables

Losses in cables are proportional to the current squared, and are measured by the kWh meter of the installation. Reduction of the total current in a conductor by 10% for example, will reduce the losses by almost 20%.

Reduction of voltage drop

Power factor correction equipment reduce or even cancel completely the (inductive) reactive current in upstream conductors, thereby reducing or eliminating voltage drops.

Note: Over compensation will produce a voltage rise at the equipment level.

Increase in available power

By improving the power factor of a load supplied from a transformer, the current through the transformer will be reduced, thereby allowing more load to be added. In practice, it may be less expensive to improve the power factor ^[1], than to replace the transformer by a larger unit.

This matter is further elaborated in clause 6.

[1] Since other benefits are obtained from a high value of power factor, as previously noted.

3 How to improve the power factor?

Improving the power factor of an installation requires a bank of capacitors which acts as a source of reactive energy. This arrangement is said to provide reactive energy compensation

3.1 Theoretical principles

An inductive load having a low power factor requires the generators and transmission/distribution systems to pass reactive current (lagging the system voltage by 90 degrees) with associated power losses and exaggerated voltage drops, as noted in sub-clause 1.3. If a bank of shunt capacitors is added to the load, its (capacitive) reactive current will take the same path through the power system as that of the load reactive current. Since, as pointed out in sub-clause 1.3, this capacitive current I_C (which leads the system voltage by 90 degrees) is in direct phase opposition to the load reactive current (I_L). The two components flowing through the same path will cancel each other, such that if the capacitor bank is sufficiently large and $I_C = I_L$, there will be no reactive current flow in the system upstream of the capacitors.

This is indicated in Fig. L9 (a) and (b) which show the flow of the reactive components of current only.

In this figure:

R represents the active-power elements of the load

L represents the (inductive) reactive-power elements of the load

C represents the (capacitive) reactive-power elements of the power-factor correction equipment (i.e. capacitors).

It will be seen from diagram (b) of Fig. L9, that the capacitor bank C appears to be supplying all the reactive current of the load. For this reason, capacitors are sometimes referred to as “generators of leading vars”.

In diagram (c) of Fig. L9, the active-power current component has been added, and shows that the (fully-compensated) load appears to the power system as having a power factor of 1.

In general, it is not economical to fully compensate an installation.

Fig. L10 uses the power diagram discussed in sub-clause 1.2 (see Fig. L2) to illustrate the principle of compensation by reducing a large reactive power Q to a smaller value Q' by means of a bank of capacitors having a reactive power Qc. In doing so, the magnitude of the apparent power S is seen reduced to S'.

Qc can be calculated by the following formula deduced from Fig. L10:

$$Qc = P \cdot (\tan(\phi) - \tan(\phi'))$$

Example:

A motor consumes 100 kW at a power factor of 0.75 (i.e. $\tan \phi = 0.88$). To improve the power factor to 0.93 (i.e. $\tan \phi = 0.4$), the reactive power of the capacitor bank must be : $Qc = 100 (0.88 - 0.4) = 48 \text{ kvar}$

The selected level of compensation and the calculation of rating for the capacitor bank depend on the particular installation. The factors requiring attention are explained in a general way in clause 5, and in clauses 6 and 7 for transformers and motors.

Note: Before starting a compensation project, a number of precautions should be observed. In particular, oversizing of motors should be avoided, as well as the no-load running of motors. In this latter condition, the reactive energy consumed by a motor results in a very low power factor (≈ 0.17); this is because the kW taken by the motor (when it is unloaded) are very small.

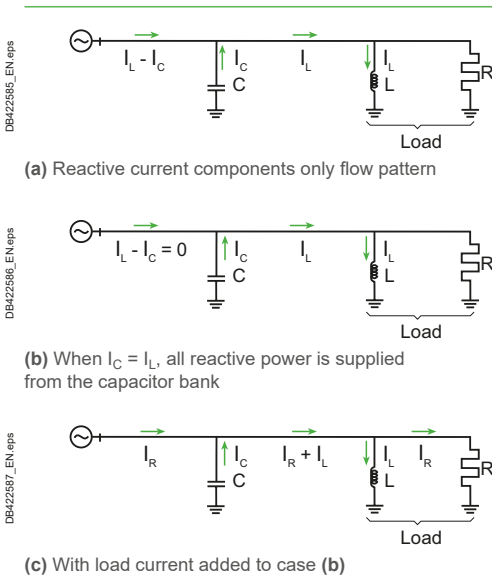


Fig. L9 Showing the essential features of power-factor correction

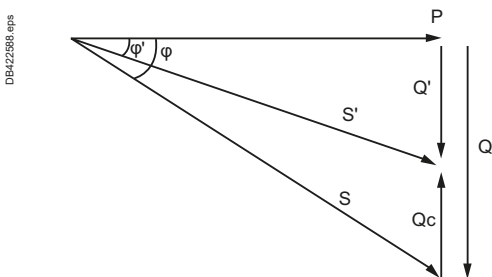


Fig. L10 Diagram showing the principle of compensation: $Qc = P (\tan \phi - \tan \phi')$

3.2 By using what equipment?

Compensation at LV

At low voltage, compensation is provided by:

- Fixed-value capacitor
- Equipment providing automatic regulation, or banks which allow continuous adjustment according to requirements, as loading of the installation changes

Note: When the installed reactive power of compensation exceeds 800 kvar, and the load is continuous and stable, it is often found to be economically advantageous to install capacitor banks at the medium voltage level.

3 How to improve the power factor?

Compensation can be carried out by a fixed value of capacitance in favourable circumstances

Fixed capacitors (see Fig. L11)

This arrangement employs one or more capacitor(s) to form a constant level of compensation. Control may be:

- Manual: by circuit breaker or load-break switch
- Semi-automatic: by contactor
- Direct connection to an appliance and switched with it

These capacitors are applied:

- At the terminals of inductive devices (motors and transformers)
- At busbars supplying numerous small motors and inductive appliance for which individual compensation would be too costly
- In cases where the level of load is reasonably constant

PB116795.eps



Fig. L11 Example of fixed-value compensation capacitors

Compensation is more-commonly effected by means of an automatically-controlled stepped bank of capacitors

Automatic capacitor banks (see Fig. L12)

This kind of equipment provides automatic control of compensation, maintaining the power factor within close limits around a selected level. Such equipment is applied at points in an installation where the active-power and/or reactive-power variations are relatively large, for example:

- At the busbars of a general power distribution board
- At the terminals of a heavily-loaded feeder cable

PB116796.eps



Fig. L12 Example of automatic-compensation-regulating equipment

3 How to improve the power factor?

Automatically-regulated banks of capacitors allow an immediate adaptation of compensation to match the level of load

The principles of, and reasons, for using automatic compensation

A bank of capacitors is divided into a number of sections, each of which is controlled by a contactor. Closure of a contactor switches its section into parallel operation with other sections already in service. The size of the bank can therefore be increased or decreased in steps, by the closure and opening of the controlling contactors.

A control relay monitors the power factor of the controlled circuit(s) and is arranged to close and open appropriate contactors to maintain a reasonably constant system power factor (within the tolerance imposed by the size of each step of compensation). The current transformer for the monitoring relay must evidently be placed on one phase of the incoming cable which supplies the circuit(s) being controlled, as shown in **Fig. L13**.

Power factor correction equipment including static contactors (thyristors) instead of usual contactors is particularly suitable for a certain number of installations using equipment with fast cycle and/or sensitive to transient surges.

The advantages of static contactors are :

- Immediate response to all power factor fluctuation (response time as low as 40 ms according to regulator option)
- Unlimited number of operations
- Elimination of transient phenomena on the network on capacitor switching
- Fully silent operation

By closely matching compensation to that required by the load, the possibility of producing overvoltages at times of low load will be avoided, thereby preventing an overvoltage condition, and possible damage to appliances and equipment. Overvoltages due to excessive reactive compensation depend partly on the value of source impedance.

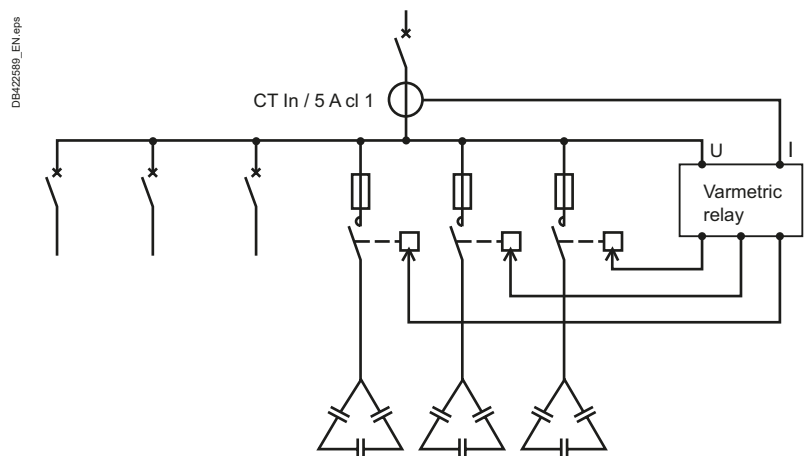


Fig. L13 The principle of automatic-compensation control

3.3 The choice between a fixed or automatically-regulated bank of capacitors

Commonly-applied rules

Where the kvar rating of the capacitors is less than, or equal to 15% of the supply transformer rating, a fixed value of compensation is appropriate. Above the 15% level, it is advisable to install an automatically-controlled bank of capacitors.

The location of low-voltage capacitors in an installation constitutes the mode of compensation, which may be global (one location for the entire installation), partial (section-by-section), local (at each individual device), or some combination of the latter two. In principle, the ideal compensation is applied at a point of consumption and at the level required at any instant.

In practice, technical and economic factors govern the choice.

4 Where to install power factor correction capacitors?

Where a load is continuous and stable, global compensation can be applied

4.1 Global compensation (see Fig. L14)

Principle

The capacitor bank is connected to the busbars of the main LV distribution board for the installation, and remains in service during the period of normal load.

Advantages

The global type of compensation:

- Reduces the tariff penalties for excessive consumption of kvars
- Reduces the apparent power kVA demand, on which standing charges are usually based
- Relieves the supply transformer, which is then able to accept more load if necessary

Comments

- Reactive current still flows in all conductors of cables leaving (i.e. downstream of) the main LV distribution board
- For the above reason, the sizing of these cables, and power losses in them, are not improved by the global mode of compensation.

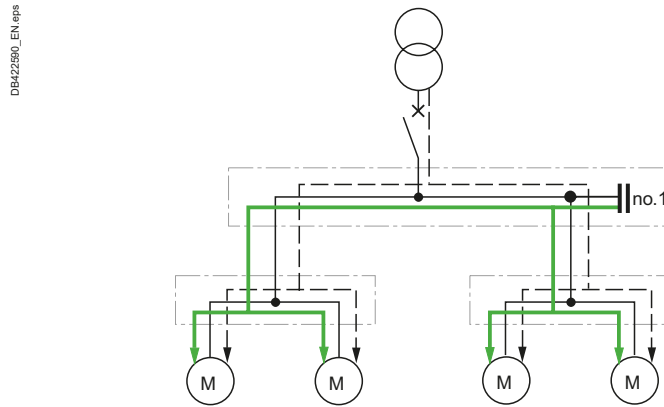


Fig. L14 Global compensation

Compensation by sector is recommended when the installation is extensive, and where the load/time patterns differ from one part of the installation to another

4.2 Compensation by sector

Principle

Capacitor banks are connected to busbars of each local distribution board, as shown in Fig. L15.

A significant part of the installation benefits from this arrangement, notably the feeder cables from the main distribution board to each of the local distribution boards at which the compensation measures are applied.

Advantages

The compensation by sector:

- Reduces the tariff penalties for excessive consumption of kvars
- Reduces the apparent power kVA demand, on which standing charges are usually based
- Relieves the supply transformer, which is then able to accept more load if necessary
- The size of the cables supplying the local distribution boards may be reduced, or will have additional capacity for possible load increases
- Losses in the same cables will be reduced

Comments

- Reactive current still flows in all cables downstream of the local distribution boards
- For the above reason, the sizing of these cables, and the power losses in them, are not improved by compensation by sector
- Where large changes in loads occur, there is always a risk of overcompensation and consequent overvoltage problems

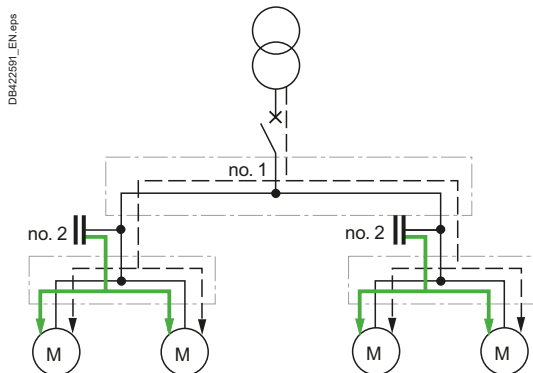


Fig. L15 Compensation by sector

4 Where to install power factor correction capacitors?

Individual compensation should be considered when the power of motor is significant with respect to power of the installation

4.3 Individual compensation

Principle

Capacitors are connected directly to the terminals of inductive circuit (notably motors, see further in Clause 7). Individual compensation should be considered when the power of the motor is significant with respect to the declared power requirement (kVA) of the installation.

The kvar rating of the capacitor bank is in the order of 25% of the kW rating of the motor. Complementary compensation at the origin of the installation (transformer) may also be beneficial.

Advantages

Individual compensation:

- Reduces the tariff penalties for excessive consumption of kvars
- Reduces the apparent power kVA demand
- Reduces the size of all cables as well as the cable losses

Comments

- Significant reactive currents no longer exist in the installation

5 How to determine the optimum level of compensation?

5.1 General method

Listing of reactive power demands at the design stage

This listing can be made in the same way (and at the same time) as that for the power loading described in chapter A. The levels of active and reactive power loading, at each level of the installation (generally at points of distribution and sub-distribution of circuits) can then be determined.

Technical-economic optimization for an existing installation

The optimum rating of compensation capacitors for an existing installation can be determined from the following principal considerations:

- Electricity bills prior to the installation of capacitors
 - Future electricity bills anticipated following the installation of capacitors
 - Costs of:
 - Purchase of capacitors and control equipment (contactors, relaying, cabinets, etc.)
 - Installation and maintenance costs
 - Cost of dielectric heating losses in the capacitors, versus reduced losses in cables, transformer, etc., following the installation of capacitors
- Several simplified methods applied to typical tariffs (common in Europe) are shown in sub-clauses 5.3 and 5.4.

5.2 Simplified method

General principle

An approximate calculation is generally adequate for most practical cases, and may be based on the assumption of a power factor of 0.8 (lagging) before compensation. In order to improve the power factor to a value sufficient to avoid tariff penalties (this depends on local tariff structures, but is assumed here to be 0.93) and to reduce losses, volt-drops, etc. in the installation, reference can be made to **Fig. L16** next page.

From the figure, it can be seen that, to raise the power factor of the installation from 0.8 to 0.93 will require 0.355 kvar per kW of load. The rating of a bank of capacitors at the busbars of the main distribution board of the installation would be

$$Q \text{ (kvar)} = 0.355 \times P \text{ (kW)}.$$

This simple approach allows a rapid determination of the compensation capacitors required, albeit in the global, partial or independent mode.

Example

It is required to improve the power factor of a 666 kVA installation from 0.75 to 0.928. The active power demand is $666 \times 0.75 = 500$ kW.

In **Fig. L16**, the intersection of the row $\cos \phi = 0.75$ (before correction) with the column $\cos \phi = 0.93$ (after correction) indicates a value of 0.487 kvar of compensation per kW of load.

For a load of 500 kW, therefore, $500 \times 0.487 = 244$ kvar of capacitive compensation is required.

Note: this method is valid for any voltage level, i.e. is independent of voltage.

5 How to determine the optimum level of compensation?

Before compensation		kvar rating of capacitor bank to install per kW of load, to improve cos (the power factor) or tan, to a given value													
tan φ	cos φ	tan φ	0.75	0.59	0.48	0.46	0.43	0.40	0.36	0.33	0.29	0.25	0.20	0.14	0.0
		cos φ	0.80	0.86	0.90	0.91	0.92	0.93	0.94	0.9&5	0.96	0.97	0.98	0.99	1
2.29	0.40		1.557	1.691	1.805	1.832	1.861	1.895	1.924	1.959	1.998	2.037	2.085	2.146	2.288
2.22	0.41		1.474	1.625	1.742	1.769	1.798	1.831	1.840	1.896	1.935	1.973	2.021	2.082	2.225
2.16	0.42		1.413	1.561	1.681	1.709	1.738	1.771	1.800	1.836	1.874	1.913	1.961	2.022	2.164
2.10	0.43		1.356	1.499	1.624	1.651	1.680	1.713	1.742	1.778	1.816	1.855	1.903	1.964	2.107
2.04	0.44		1.290	1.441	1.558	1.585	1.614	1.647	1.677	1.712	1.751	1.790	1.837	1.899	2.041
1.98	0.45		1.230	1.384	1.501	1.532	1.561	1.592	1.628	1.659	1.695	1.737	1.784	1.846	1.988
1.93	0.46		1.179	1.330	1.446	1.473	1.502	1.533	1.567	1.600	1.636	1.677	1.725	1.786	1.929
1.88	0.47		1.130	1.278	1.397	1.425	1.454	1.485	1.519	1.532	1.588	1.629	1.677	1.758	1.881
1.83	0.48		1.076	1.228	1.343	1.370	1.400	1.430	1.464	1.497	1.534	1.575	1.623	1.684	1.826
1.78	0.49		1.030	1.179	1.297	1.326	1.355	1.386	1.420	1.453	1.489	1.530	1.578	1.639	1.782
1.73	0.50		0.982	1.232	1.248	1.276	1.303	1.337	1.369	1.403	1.441	1.481	1.529	1.590	1.732
1.69	0.51		0.936	1.087	1.202	1.230	1.257	1.291	1.323	1.357	1.395	1.435	1.483	1.544	1.686
1.64	0.52		0.894	1.043	1.160	1.188	1.215	1.249	1.281	1.315	1.353	1.393	1.441	1.502	1.644
1.60	0.53		0.850	1.000	1.116	1.144	1.171	1.205	1.237	1.271	1.309	1.349	1.397	1.458	1.600
1.56	0.54		0.809	0.959	1.075	1.103	1.130	1.164	1.196	1.230	1.268	1.308	1.356	1.417	1.559
1.52	0.55		0.769	0.918	1.035	1.063	1.090	1.124	1.156	1.190	1.228	1.268	1.316	1.377	1.519
1.48	0.56		0.730	0.879	0.996	1.024	1.051	1.085	1.117	1.151	1.189	1.229	1.277	1.338	1.480
1.44	0.57		0.692	0.841	0.958	0.986	1.013	1.047	1.079	1.113	1.151	1.191	1.239	1.300	1.442
1.40	0.58		0.665	0.805	0.921	0.949	0.976	1.010	1.042	1.076	1.114	1.154	1.202	1.263	1.405
1.37	0.59		0.618	0.768	0.884	0.912	0.939	0.973	1.005	1.039	1.077	1.117	1.165	1.226	1.368
1.33	0.60		0.584	0.733	0.849	0.878	0.905	0.939	0.971	1.005	1.043	1.083	1.131	1.192	1.334
1.30	0.61		0.549	0.699	0.815	0.843	0.870	0.904	0.936	0.970	1.008	1.048	1.096	1.157	1.299
1.27	0.62		0.515	0.665	0.781	0.809	0.836	0.870	0.902	0.936	0.974	1.014	1.062	1.123	1.265
1.23	0.63		0.483	0.633	0.749	0.777	0.804	0.838	0.870	0.904	0.942	0.982	1.030	1.091	1.233
1.20	0.64		0.450	0.601	0.716	0.744	0.771	0.805	0.837	0.871	0.909	0.949	0.997	1.058	1.200
1.17	0.65		0.419	0.569	0.685	0.713	0.740	0.774	0.806	0.840	0.878	0.918	0.966	1.027	1.169
1.14	0.66		0.388	0.538	0.654	0.682	0.709	0.743	0.775	0.809	0.847	0.887	0.935	0.996	1.138
1.11	0.67		0.358	0.508	0.624	0.652	0.679	0.713	0.745	0.779	0.817	0.857	0.905	0.966	1.108
1.08	0.68		0.329	0.478	0.595	0.623	0.650	0.684	0.716	0.750	0.788	0.828	0.876	0.937	1.079
1.05	0.69		0.299	0.449	0.565	0.593	0.620	0.654	0.686	0.720	0.758	0.798	0.840	0.901	1.043
1.02	0.70		0.270	0.420	0.536	0.564	0.591	0.625	0.657	0.691	0.729	0.769	0.811	0.872	1.014
0.99	0.71		0.242	0.392	0.508	0.536	0.563	0.597	0.629	0.663	0.701	0.741	0.783	0.844	0.986
0.96	0.72		0.213	0.364	0.479	0.507	0.534	0.568	0.600	0.634	0.672	0.712	0.754	0.815	0.957
0.94	0.73		0.186	0.336	0.452	0.480	0.507	0.541	0.573	0.607	0.645	0.685	0.727	0.788	0.930
0.91	0.74		0.159	0.309	0.425	0.453	0.480	0.514	0.546	0.580	0.618	0.658	0.700	0.761	0.903
0.88	0.75		0.132	0.282	0.398	0.426	0.453	0.487	0.519	0.553	0.591	0.631	0.673	0.734	0.876
0.86	0.76		0.105	0.255	0.371	0.399	0.426	0.460	0.492	0.526	0.564	0.604	0.652	0.713	0.855
0.83	0.77		0.079	0.229	0.345	0.373	0.400	0.434	0.466	0.500	0.538	0.578	0.620	0.681	0.823
0.80	0.78		0.053	0.202	0.319	0.347	0.374	0.408	0.440	0.474	0.512	0.552	0.594	0.655	0.797
0.78	0.79		0.026	0.176	0.292	0.320	0.347	0.381	0.413	0.447	0.485	0.525	0.567	0.628	0.770
0.75	0.80			0.150	0.266	0.294	0.321	0.355	0.387	0.421	0.459	0.499	0.541	0.602	0.744
0.72	0.81			0.124	0.240	0.268	0.295	0.329	0.361	0.395	0.433	0.473	0.515	0.576	0.718
0.70	0.82			0.098	0.214	0.242	0.269	0.303	0.335	0.369	0.407	0.447	0.489	0.550	0.692
0.67	0.83			0.072	0.188	0.216	0.243	0.277	0.309	0.343	0.381	0.421	0.463	0.524	0.666
0.65	0.84			0.046	0.162	0.190	0.217	0.251	0.283	0.317	0.355	0.395	0.437	0.498	0.640
0.62	0.85			0.020	0.136	0.164	0.191	0.225	0.257	0.291	0.329	0.369	0.411	0.472	0.614
0.59	0.86				0.109	0.140	0.167	0.198	0.230	0.264	0.301	0.343	0.390	0.451	0.593
0.57	0.87				0.083	0.114	0.141	0.172	0.204	0.238	0.275	0.317	0.364	0.425	0.567
0.54	0.88				0.054	0.085	0.112	0.143	0.175	0.209	0.246	0.288	0.335	0.396	0.538
0.51	0.89				0.028	0.059	0.086	0.117	0.149	0.183	0.230	0.262	0.309	0.370	0.512
0.48	0.90					0.031	0.058	0.089	0.121	0.155	0.192	0.234	0.281	0.342	0.484

Value selected as an example on section 5.2

Value selected as an example on section 5.4

Fig. L16 kvar to be installed per kW of load, to improve the power factor of an installation

5 How to determine the optimum level of compensation?

In the case of certain (common) types of tariff, an examination of several bills covering the most heavily-loaded period of the year allows determination of the kvar level of compensation required to avoid kvarh (reactive-energy) charges. The pay-back period of a bank of power-factor-correction capacitors and associated equipment is generally about 18 months.

5.3 Method based on the avoidance of tariff penalties

The following method allows calculation of the rating of a proposed capacitor bank, based on billing details, where the tariff structure corresponds with (or is similar to) the one described in sub-clause 2.1 of this chapter.

The method determines the minimum compensation required to avoid these charges which are based on kvarh consumption.

The procedure is as follows:

- Refer to the bills covering consumption for the 5 months of winter (in France these are November to March inclusive).

Note: in tropical climates the summer months may constitute the period of heaviest loading and highest peaks (owing to extensive air conditioning loads) so that a consequent variation of high-tariff periods is necessary in this case. The remainder of this example will assume Winter conditions in France.

- Identify the line on the bills referring to “reactive-energy consumed” and “kvarh to be charged”. Choose the bill which shows the highest charge for kvarh (after checking that this was not due to some exceptional situation).
For example: 15,966 kvarh in January.

- Evaluate the total period of loaded operation of the installation for that month, for instance: 220 hours (22 days x 10 hours). The hours which must be counted are those occurring during the heaviest load and the highest peak loads occurring on the power system. These are given in the tariff documents, and are (commonly) during a 16-hour period each day, either from 06.00 h to 22.00 h or from 07.00 h to 23.00 h according to the region. Outside these periods, no charge is made for kvarh consumption.

- The necessary value of compensation in kvar = kvarh billed/number of hours of operation^[1] = Qc

The rating of the installed capacitor bank is generally chosen to be slightly larger than that calculated.

Certain manufacturers can provide “slide rules” especially designed to facilitate these kinds of calculation, according to particular tariffs. These devices and accompanying documentation advice on suitable equipment and control schemes, as well as drawing attention to constraints imposed by harmonic voltages on the power system. Such voltages require either over dimensioned capacitors (in terms of heat-dissipation, voltage and current ratings) and/or harmonic-suppression inductors or filters.

5.4 Method based on reduction of declared maximum apparent power (kVA)

For consumers whose tariffs are based on a fixed charge per kVA declared, plus a charge per kWh consumed, it is evident that a reduction in declared kVA would be beneficial. The diagram of Fig. L17 shows that as the power factor improves, the kVA value diminishes for a given value of kW (P). The improvement of the power factor is aimed at (apart from other advantages previously mentioned) reducing the declared level and never exceeding it, thereby avoiding the payment of an excessive price per kVA during the periods of excess, and/or tripping of the the main circuit breaker. Fig. L16 (previous page) indicates the value of kvar of compensation per kW of load, required to improve from one value of power factor to another.

Example:

A supermarket has a declared load of 122 kVA at a power factor of 0.7 lagging, i.e. an active-power load of 85.4 kW. The particular contract for this consumer was based on stepped values of declared kVA (in steps of 6 kVA up to 108 kVA, and 12 kVA steps above that value, this is a common feature in many types of two-part tariff). In the case being considered, the consumer was billed on the basis of 132 kVA. Referring to Fig. L16, it can be seen that a 60 kvar bank of capacitors will improve the power factor of the load from 0.7 to 0.95 (0.691 x 85.4 = 59 kvar in the

figure). The declared value of kVA will then be $\frac{85.4}{0.95} = 90$ kVA, i.e. an improvement of 30%.

For 2-part tariffs based partly on a declared value of kVA, Fig. L18 allows determination of the kvar of compensation required to reduce the value of kVA declared, and to avoid exceeding it.

DB422582.eps

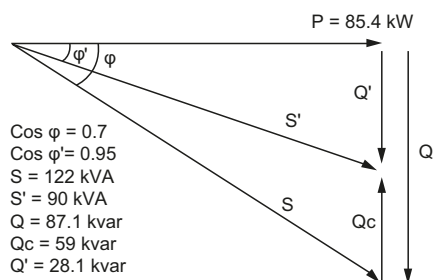


Fig. L17 Reduction of declared maximum kVA by power-factor improvement

[1] In the billing period, during the hours for which reactive energy is charged for the case considered above:

$$Q_c = \frac{15,996 \text{ kvarh}}{220 \text{ h}} = 73 \text{ kvar}$$

6 Compensation at the terminals of a transformer

6.1 Compensation to increase the available active power output

The installation of a capacitor bank can avoid the need to change a transformer in the event of a load increase

Steps similar to those taken to reduce the declared maximum kVA, i.e. improvement of the load power factor, as discussed in subclause 5.4, will maximise the available transformer capacity, i.e. to supply more active power.

Cases can arise where the replacement of a transformer by a larger unit, to overcome a load growth, may be avoided by this means. Fig. L18 shows directly the power (kW) capability of fully-loaded transformers at different load power factors, from which the increase of active-power output can be obtained as the value of power factor increases.

tan φ	cos φ	Nominal rating of transformers (in kVA)											
		100	160	250	315	400	500	630	800	1000	1250	1600	2000
0.00	1	100	160	250	315	400	500	630	800	1000	1250	1600	2000
0.20	0.98	98	157	245	309	392	490	617	784	980	1225	1568	1960
0.29	0.96	96	154	240	302	384	480	605	768	960	1200	1536	1920
0.36	0.94	94	150	235	296	376	470	592	752	940	1175	1504	1880
0.43	0.92	92	147	230	290	368	460	580	736	920	1150	1472	1840
0.48	0.90	90	144	225	284	360	450	567	720	900	1125	1440	1800
0.54	0.88	88	141	220	277	352	440	554	704	880	1100	1408	1760
0.59	0.86	86	138	215	271	344	430	541	688	860	1075	1376	1720
0.65	0.84	84	134	210	265	336	420	529	672	840	1050	1344	1680
0.70	0.82	82	131	205	258	328	410	517	656	820	1025	1312	1640
0.75	0.80	80	128	200	252	320	400	504	640	800	1000	1280	1600
0.80	0.78	78	125	195	246	312	390	491	624	780	975	1248	1560
0.86	0.76	76	122	190	239	304	380	479	608	760	950	1216	1520
0.91	0.74	74	118	185	233	296	370	466	592	740	925	1184	1480
0.96	0.72	72	115	180	227	288	360	454	576	720	900	1152	1440
1.02	0.70	70	112	175	220	280	350	441	560	700	875	1120	1400

Fig. L18 Active-power capability of fully-loaded transformers, when supplying loads at different values of power factor

L16

DE422503.eps

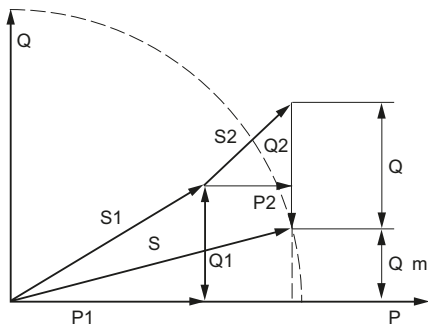


Fig. L19 Compensation Q allows the installation-load extension S2 to be added, without the need to replace the existing transformer, the output of which is limited to S

Example: (see Fig. L19).

An installation is supplied from a 630 kVA transformer loaded at 450 kW (P1) with a mean power factor of 0.8 lagging. The apparent power $S_1 = \frac{450}{0.8} = 562$ kVA

The corresponding reactive power

$$Q_1 = \sqrt{S_1^2 - P_1^2} = 337 \text{ kvar}$$

The anticipated load increase P2 = 100 kW at a power factor of 0.7 lagging.

The apparent power $S_2 = \frac{100}{0.7} = 143$ kVA

The corresponding reactive power

$$Q_2 = \sqrt{S_2^2 - P_2^2} = 102 \text{ kvar}$$

What is the minimum value of capacitive kvar to be installed, in order to avoid a change of transformer?

Total power now to be supplied:

$$P = P_1 + P_2 = 550 \text{ kW}$$

The maximum reactive power capability of the 630 kVA transformer when delivering 550 kW is:

$$Q_m = \sqrt{S^2 - P^2} \quad Q_m = \sqrt{630^2 - 550^2} = 307 \text{ kvar}$$

Total reactive power required by the installation before compensation:

$$Q_1 + Q_2 = 337 + 102 = 439 \text{ kvar}$$

So that the minimum size of capacitor bank to install:

$$Q_{\text{kvar}} = 439 - 307 = 132 \text{ kvar}$$

It should be noted that this calculation has not taken into account the load peaks and their duration.

The best possible improvement, i.e. correction which attains a power factor of 1 would permit a power reserve for the transformer of $630 - 550 = 80$ kW.

The capacitor bank would then have to be rated at 439 kvar.

6 Compensation at the terminals of a transformer

Where metering is carried out at the MV side of a transformer, the reactive-energy losses in the transformer may need to be compensated (depending on the tariff)

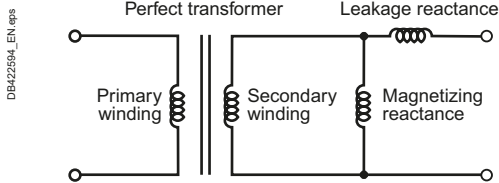


Fig. L20 Transformer reactances per phase

The reactive power absorbed by a transformer cannot be neglected, and can amount to (about) 5% of the transformer rating when supplying its full load. Compensation can be provided by a bank of capacitors. In transformers, reactive power is absorbed by both shunt (magnetizing) and series (leakage flux) reactances. Complete compensation can be provided by a bank of shunt-connected LV capacitors

6.2 Compensation of reactive energy absorbed by the transformer

The nature of transformer inductive reactances

All previous references have been to shunt connected devices such as those used in normal loads, and power factor-correcting capacitor banks etc. The reason for this is that shunt connected equipment requires (by far) the largest quantities of reactive energy in power systems; however, series-connected reactances, such as the inductive reactances of power lines and the leakage reactance of transformer windings, etc., also absorb reactive energy.

Where metering is carried out at the MV side of a transformer, the reactive-energy losses in the transformer may (depending on the tariff) need to be compensated.

As far as reactive-energy losses only are concerned, a transformer may be represented by the elementary diagram of Fig. L20. All reactance values are referred to the secondary side of the transformer, where the shunt branch represents the magnetizing-current path. The magnetizing current remains practically constant (at about 1.8% of full-load current) from no load to full load, in normal circumstances, i.e. with a constant primary voltage, so that a shunt capacitor of fixed value can be installed at the MV or LV side, to compensate for the reactive energy absorbed.

Reactive-power absorption in series-connected (leakage flux) reactance XL

A simple illustration of this phenomenon is given by the vector diagram of Fig. L21. The reactive-current component through the load = $I \sin \phi$ so that $Q_L = VI \sin \phi$.

The reactive-current component from the source = $I \sin \phi'$ so that $Q_E = EI \sin \phi'$.

It can be seen that $E > V$ and $\sin \phi' > \sin \phi$.

The difference between $EI \sin \phi'$ and $VI \sin \phi$ gives the kvar per phase absorbed by X_L .

It can be shown that this kvar value is equal to $I^2 X_L$ (which is analogous to the $I^2 R$ active power (kW) losses due to the series resistance of power lines, etc.).

From the $I^2 X_L$ formula it is very simple to deduce the kvar absorbed at any load value for a given transformer, as follows:

If per-unit values are used (instead of percentage values) direct multiplication of I and X_L can be carried out.

Example:

A 630 kVA transformer with a short-circuit reactance voltage of 4% is fully loaded.

What is its reactive-power (kvar) loss?

$X_L = 0.04$ pu and $I = 1$ pu

loss = $I^2 X_L = 1^2 \times 0.04 = 0.04$ pu kvar

where 1 pu = 630 kVA

The 3-phase kvar losses are $630 \times 0.04 = 25.2$ kvar (or, quite simply, 4% of 630 kVA).

At half load i.e. $I = 0.5$ pu the losses will be $0.5^2 \times 0.04 = 0.01$ pu = $630 \times 0.01 = 6.3$ kvar and so on...

This example, and the vector diagram of Fig. L21 show that:

- The power factor at the primary side of a loaded transformer is different (normally lower) than that at the secondary side (due to the absorption of vars)
- Full-load kvar losses due to leakage reactance are equal to the transformer percentage reactance (4% reactance means a kvar loss equal to 4% of the kVA rating of the transformer)
- kvar losses due to leakage reactance vary according to the current (or kVA loading) squared

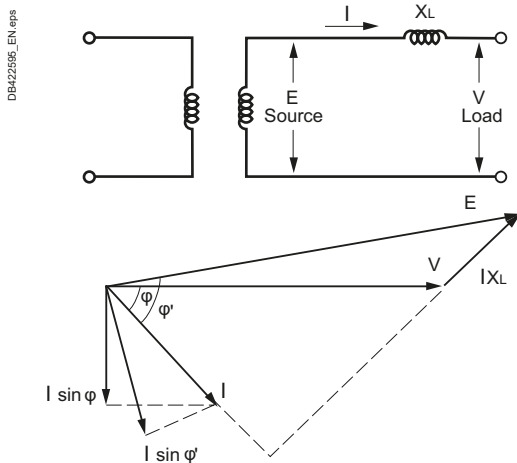


Fig. L21 Reactive power absorption by series inductance

6 Compensation at the terminals of a transformer

To determine the total kvar losses of a transformer the constant magnetizing-current circuit losses (approx. 1.8% of the transformer kVA rating) must be added to the foregoing "series" losses. Fig. L22 shows the no-load and full-load kvar losses for typical distribution transformers. In principle, series inductances can be compensated by fixed series capacitors (as is commonly the case for long MV transmission lines). This arrangement is operationally difficult, however, so that, at the voltage levels covered by this guide, shunt compensation is always applied. In the case of MV metering, it is sufficient to raise the power factor to a point where the transformer plus load reactive-power consumption is below the level at which a billing charge is made. This level depends on the tariff, but often corresponds to a $\tan \phi$ value of 0.31 ($\cos \phi$ of 0.955).

Rated power (kVA)	Reactive power (kvar) to be compensated	
	No load	Full load
100	2.5	6.1
160	3.7	9.6
250	5.3	14.7
315	6.3	18.4
400	7.6	22.9
500	9.5	28.7
630	11.3	35.7
800	20	54.5
1000	23.9	72.4
1250	27.4	94.5
1600	31.9	126
2000	37.8	176

Fig. L22 Reactive power consumption of distribution transformers with 20 kV primary windings

As a matter of interest, the kvar losses in a transformer can be completely compensated by adjusting the capacitor bank to give the load a (slightly) leading power factor. In such a case, all of the kvar of the transformer is being supplied from the capacitor bank, while the input to the MV side of the transformer is at unity power factor, as shown in Fig. L23.

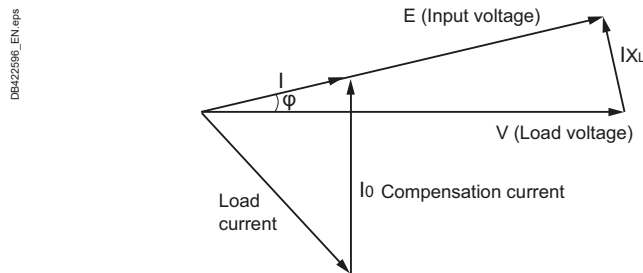


Fig. L23 Overcompensation of load to completely compensate transformer reactive-power losses

In practical terms, therefore, compensation for transformer-absorbed kvar is included in the capacitors primarily intended for power factor correction of the load, either globally, partially, or in the individual mode. Unlike most other kvar-absorbing items, the transformer absorption (i.e. the part due to the leakage reactance) changes significantly with variations of load level, so that, if individual compensation is applied to the transformer, then an average level of loading will have to be assumed.

Fortunately, this kvar consumption generally forms only a relatively small part of the total reactive power of an installation, and so mismatching of compensation at times of load change is not likely to be a problem.

Fig. L22 indicates typical kvar loss values for the magnetizing circuit ("no-load kvar" columns), as well as for the total losses at full load, for a standard range of distribution transformers supplied at 20 kV (which include the losses due to the leakage reactance).

7 Power factor correction of induction motors

Individual motor compensation is recommended where the motor power (kVA) is large with respect to the declared power of the installation.

7.1 Connection of a capacitor bank and protection settings

General precautions

Because of the small kW consumption, the power factor of a motor is very low at no-load or on light load. The reactive current of the motor remains practically constant at all loads, so that a number of unloaded motors constitute a consumption of reactive power which is generally detrimental to an installation, for reasons explained in preceding sections.

Two good general rules therefore are that unloaded motors should be switched off, and motors should not be oversized (since they will then be lightly loaded).

Connection

The bank of capacitors should be connected directly to the terminals of the motor.

Special motors

It is recommended that special motors (stepping, plugging, inching, reversing motors, etc.) should not be compensated.

Effect on protection settings

After applying compensation to a motor, the current to the motor-capacitor combination will be lower than before, assuming the same motor-driven load conditions. This is because a significant part of the reactive component of the motor current is being supplied from the capacitor, as show in Fig. L24.

Where the overcurrent protection devices of the motor are located upstream of the motor capacitor connection (and this will always be the case for terminal-connected capacitors), the overcurrent relay settings must be reduced in the ratio:

$\cos \phi$ before compensation / $\cos \phi$ after compensation.

For motors compensated in accordance with the kvar values indicated in Fig. L25 (maximum values recommended for avoidance of self-excitation of standard induction motors, as discussed in sub-clause 7.2), the above-mentioned ratio will have a value similar to that indicated for the corresponding motor speed in Fig. L26.

DB422597_EN.eps

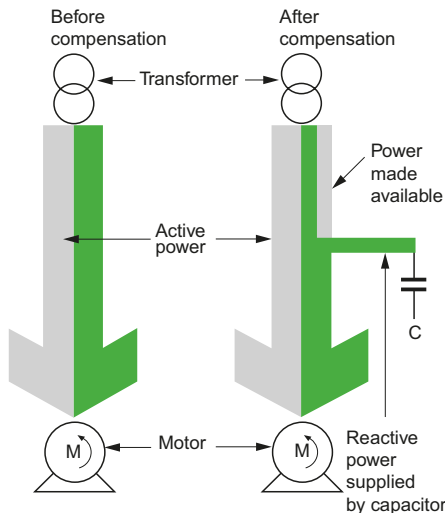


Fig. L24 Before compensation, the transformer supplies all the reactive power; after compensation, the capacitor supplies a large part of the reactive power

3-phase motors 230/400 V					
Nominal power		kvar to be installed			
kW	hp	Speed of rotation (rpm)			
		3000	1500	1000	750
22	30	6	8	9	10
30	40	7.5	10	11	12.5
37	50	9	11	12.5	16
45	60	11	13	14	17
55	75	13	17	18	21
75	100	17	22	25	28
90	125	20	25	27	30
110	150	24	29	33	37
132	180	31	36	38	43
160	218	35	41	44	52
200	274	43	47	53	61
250	340	52	57	63	71
280	380	57	63	70	79
355	482	67	76	86	98
400	544	78	82	97	106
450	610	87	93	107	117

Fig. L25 Maximum kvar of power factor correction applicable to motor terminals without risk of self excitation

Speed in rpm	Reduction factor
750	0.88
1000	0.90
1500	0.91
3000	0.93

Fig. L26 Reduction factor for overcurrent protection after compensation

7 Power factor correction of induction motors

When a capacitor bank is connected to the terminals of an induction motor, it is important to check that the size of the bank is less than that at which self-excitation can occur.

7.2 How self-excitation of an induction motor can be avoided

When a motor is driving a high-inertia load, the motor will continue to rotate (unless deliberately braked) after the motor supply has been switched off.

The “magnetic inertia” of the rotor circuit means that an emf will be generated in the stator windings for a short period after switching off, and would normally reduce to zero after 1 or 2 cycles, in the case of an uncompensated motor.

Compensation capacitors however, constitute a 3-phase reactive load for this decaying emf, which causes capacitive currents to flow through the stator windings. These stator currents will produce a rotating magnetic field in the rotor which acts exactly along the same axis and in the same direction as that of the decaying magnetic field.

The rotor flux consequently increases; the stator currents increase; and the voltage at the terminals of the motor increases; sometimes to dangerously-high levels.

This phenomenon is known as self-excitation and is one reason why AC generators are not normally operated at leading power factors, i.e. there is a tendency to spontaneously (and uncontrollably) self excite.

Notes:

1. The characteristics of a motor being driven by the inertia of the load are not rigorously identical to its no-load characteristics. This assumption, however, is sufficiently accurate for practical purposes.
2. With the motor acting as a generator, the currents circulating are largely reactive, so that the braking (retarding) effect on the motor is mainly due only to the load represented by the cooling fan in the motor.
3. The (almost 90° lagging) current taken from the supply in normal circumstances by the unloaded motor, and the (almost 90° leading) current supplied to the capacitors by the motor acting as a generator, both have the same phase relationship to the terminal voltage. It is for this reason that the two characteristics may be superimposed on the graph.

In order to avoid self-excitation as described above, the kvar rating of the capacitor bank must be limited to the following maximum value:

$Q_c \leq 0.9 \times I_0 \times U_n \times \sqrt{3}$ where I_0 = the no-load current of the motor and U_n = phase-to-phase nominal voltage of the motor in kV. **Fig. L25** previous page gives appropriate values of Q_c corresponding to this criterion.

Example

A 75 kW, 3,000 rpm, 400 V, 3-phase motor may have a capacitor bank no larger than 17 kvar according to **Fig. L25**. The table values are, in general, too small to adequately compensate the motor to the level of $\cos \phi$ normally required. Additional compensation can, however, be applied to the system, for example an overall bank, installed for global compensation of a number of smaller appliances.

High-inertia motors and/or loads

In any installation where high-inertia motor driven loads exist, the circuit breakers or contactors controlling such motors should, in the event of total loss of power supply, be rapidly tripped.

If this precaution is not taken, then self excitation to very high voltages is likely to occur, since all other banks of capacitors in the installation will effectively be in parallel with those of the high-inertia motors.

The protection scheme for these motors should therefore include an overvoltage tripping relay, together with reverse-power checking contacts (the motor will feed power to the rest of the installation, until the stored inertial energy is dissipated).

If the capacitor bank associated with a high inertia motor is larger than that recommended in **Fig. L25**, then it should be separately controlled by a circuit breaker or contactor, which trips simultaneously with the main motor-controlling circuit breaker or contactor, as shown in **Fig. L27**.

Closing of the main contactor is commonly subject to the capacitor contactor being previously closed.

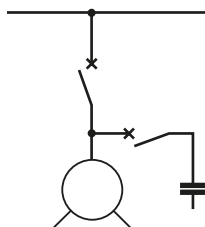
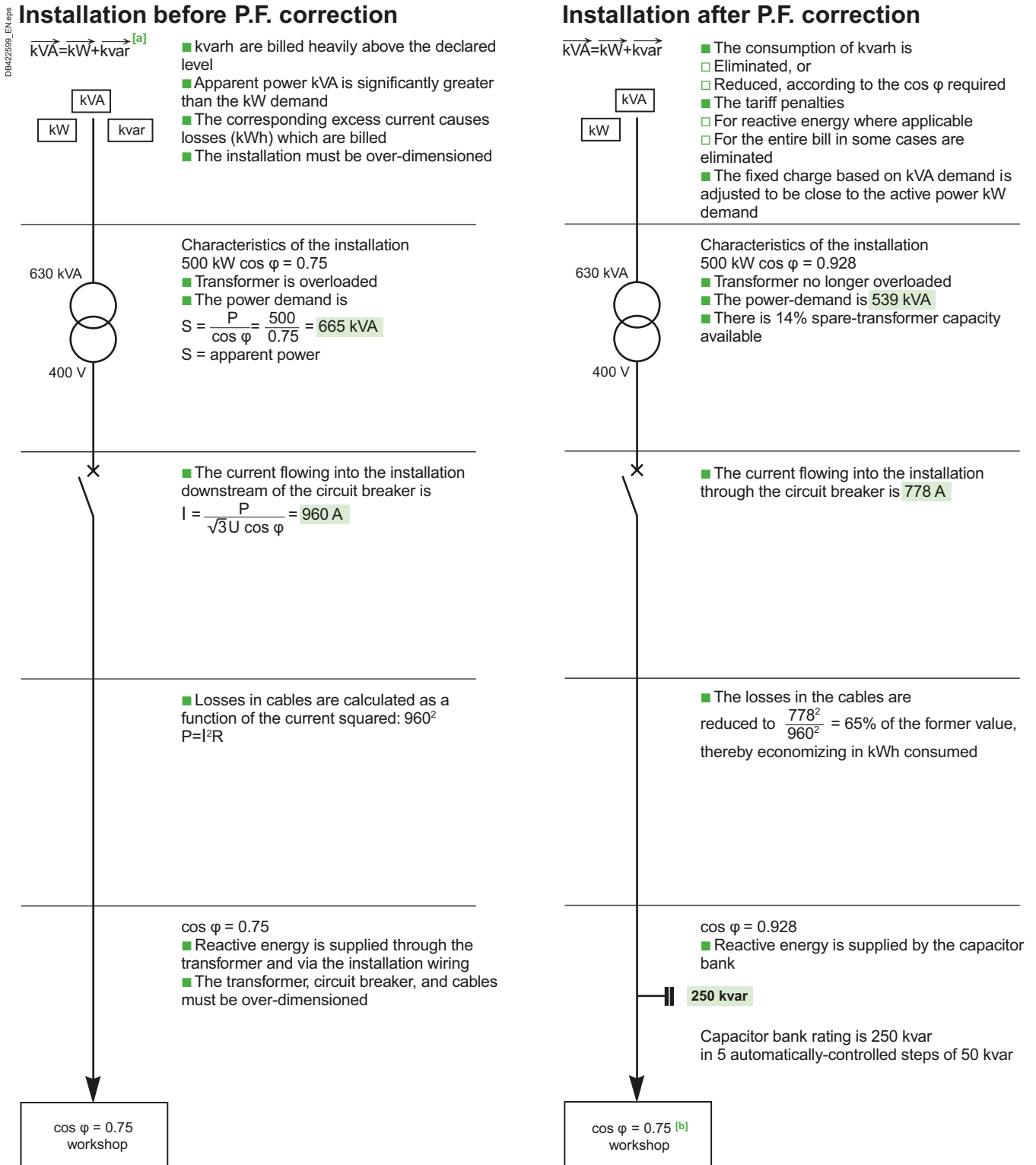


Fig. L27 Connection of the capacitor bank to the motor

DB442598.eps

8 Example of an installation before and after power-factor correction



[a] The arrows denote vector quantities.
 [b] The $\cos \phi$ of the workshop remains at 0.75 but $\cos \phi$ for all the installation upstream of the capacitor bank to the transformer LV terminals is 0.928. As mentioned in Sub-clause 6.2 the $\cos \phi$ at the HV side of the transformer will be slightly lower (particularly in the pre-corrected case), due to the reactive power losses in the transformer.

Fig. L28 Technical-economic comparison of an installation before and after power-factor correction

9 The effects of harmonics

9.1 Problems arising from power-system harmonics

The presence of harmonics in electrical systems means that current and voltage are distorted and deviate from sinusoidal waveforms.

Designers are requested to pay more and more attention to energy savings and improved availability of electricity. This is why harmonics are a growing concern in the management of electrical systems today.

Harmonics have existed from the earliest days of the industry and were (and still are) caused by the non-linear magnetizing impedances of transformers, reactors, fluorescent lamp ballasts, etc. In addition, power electronic devices have become abundant today because of their capabilities for precise process control and energy savings benefits. However, they also bring drawbacks to electrical distribution systems: harmonics.

Harmonic currents caused by nonlinear loads connected to the distribution system are flowing through the system impedances, and in turn distorts the supply voltage.

Such loads are increasingly more abundant in all industrial, commercial, and residential installations and their percentage of the total load is growing steadily.

Examples include:

- Industrial equipment (welders, induction furnaces, battery chargers, DC power supplies)
- Variable Speed Drives for AC and DC motors
- Uninterruptible Power Supplies (UPS)
- Office equipment (PCs, printers, servers, displays, etc.)
- Household appliances (TVs, microwave ovens, fluorescent, fluocompact and LED lighting, washing machines and dryers, light dimmers)

Harmonic currents increase the r.m.s. current in electrical systems and deteriorate the supply voltage quality. They stress the electrical network and potentially damage equipment. They may disrupt normal operation of devices and increase operating costs.

Symptoms of problematic harmonic levels include overheating of transformers, motors and cables, thermal tripping of protective devices and logic faults of digital devices. In addition, the life span of many devices is reduced by elevated operating temperatures.

Capacitors are especially sensitive to harmonic components of the supply voltage due to the fact that capacitive reactance decreases as the frequency increases. In practice, this means that a relatively small percentage of harmonic voltage can cause a significant current to flow in the capacitor circuit.

A number of features may be used in various ways to reduce the consequences of harmonics. In this section, practical means of reducing the influence of harmonics are recommended, with particular reference to capacitor banks. A more detailed overview is presented in **chapter M: Harmonic management**.

DB422800_EN.eps

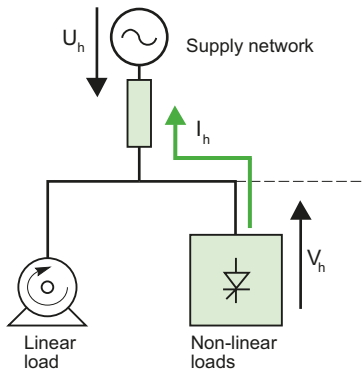


Fig. L29 Simplified circuit diagram

9.2 Risk of resonance

Considering the simplified circuit represented on Fig. L29 (no PFC capacitors connected):

The voltage distortion V_h at the busbar level results from two different factors:

- connection of non-linear loads generating harmonic currents I_h ,
- voltage distortion U_h present on the supply network due to non-linear loads outside of the considered circuit (incoming harmonic voltage).

A significant indicator of harmonic importance is the percentage of non-linear loads N_{LL} , calculated by the formula:

$$N_{LL(\%)} = \frac{\text{Power of non-linear loads}}{\text{Power of supply transformer}}$$

The connection of PFC capacitors (without reactors) results in the amplification of harmonic currents at the busbar level, and an increase of the voltage distortion.

Capacitors are linear reactive devices, and consequently do not generate harmonics. The installation of capacitors in a power system (in which the impedances are predominantly inductive) can, however, result in total or partial resonance occurring at one of the harmonic frequencies.

Because of harmonics, the current I_c circulating through the PFC capacitors is higher compared to the situation where only the fundamental current I_1 is present.

If the natural frequency of the capacitor bank/ power-system reactance combination is close to a particular harmonic, then partial resonance will occur, with amplified values of voltage and current at the harmonic frequency concerned. In this particular case, the elevated current will cause overheating of the capacitor, with degradation of the dielectric, which may result in its eventual failure.

The order h_0 of the natural resonant frequency between the system inductance and the capacitor bank is given by:

$$h_0 = \sqrt{\frac{S_{SC}}{Q}}$$

Where:

S_{SC} = the level of system short-circuit power (kVA) at the point of connection of the capacitor

Q = capacitor bank rating in kvar

h_0 = the order of the natural frequency f_0 , i.e. $f_0/50$ for a 50 Hz system, or $f_0/60$ for a 60 Hz system.

For example:

Transformer power rating: $S = 630\text{kVA}$

Short-circuit voltage: $u_{SC} = 6\%$

Short-circuit power at the busbar level: $S_{SC} \sim 10\text{ MVA}$

Reactive power of the capacitor bank: $Q = 350\text{ kvar}$

Then:

$$h_0 = \sqrt{\frac{S_{SC}}{Q}} = \sqrt{\frac{10 \cdot 10^3}{350}} = 5.5$$

The natural frequency of the capacitor/system-inductance combination is close to the 5th harmonic frequency of the system.

For a 50 Hz system, the natural frequency f_0 is then equal to $f_0 = 50 \times h_0 = 50 \times 5.5 = 275\text{ Hz}$

9 The effects of harmonics

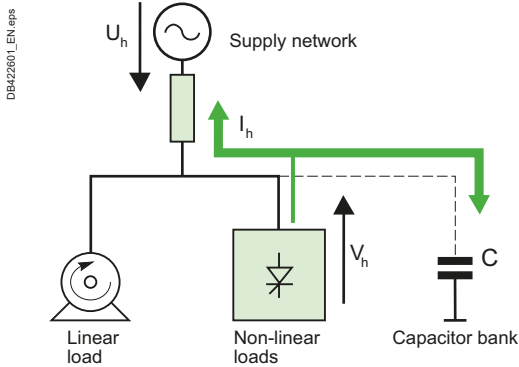


Fig. L30 Simplified circuit diagram

9.3 Possible solutions

Standard capacitors

The presence of harmonics in the supply voltage results in abnormally high current levels through the capacitors. An allowance is made for this by designing capacitors for an r.m.s. value of current equal to 1.3 times the nominal rated current. All series elements, such as connections, fuses, switches, etc., associated with the capacitors are similarly oversized, between 1.3 to 1.5 times the nominal ratings.

Standard capacitors can be used if the percentage of non-linear loads is lower than 10% ($NLL \leq 10\%$).

Capacitors with increased current rating

Capacitors with improved current capability ("heavy duty") can be used in order to increase the safety margin. The technology of these capacitors allows a higher over-current compared to what is strictly requested by the standards.

Another possibility is to use capacitors with increased rated current and voltage.

As the same reactive power must be generated, the capacitors must have the same capacitance.

With a rated voltage U_N (higher than the system voltage U), the rated current I_N and the rated power Q_N will be given by the formulas:

$$\frac{I_N}{I} = \frac{U_N}{U} \quad \text{and} \quad \frac{Q_N}{Q} = \left(\frac{U_N}{U}\right)^2$$

Capacitors with improved current rating can be used if the percentage of non-linear loads is lower than 20% ($NLL \leq 20\%$).

Connection of Power Factor Correction capacitors with detuned reactors

In order to attenuate the effects of harmonics (significant increase of capacitor current as well as high current and voltage distortion), reactors should be associated to capacitors. Reactors and capacitors are configured in a series resonant circuit, tuned so that the series resonant frequency is below the lowest harmonic frequency present in the system (see Fig. L31).

The use of detuned reactors thus prevents harmonic resonance problems, avoids the risk of overloading the capacitors and helps reduce voltage harmonic distortion in the network.

The tuning frequency can be expressed by the relative impedance of the reactor (in %, relative to the capacitor impedance), or by the tuning order, or directly in Hz.

The most common values of relative impedance are 5.7, 7 and 14 % (14 % is used with high level of 3rd harmonic voltages).

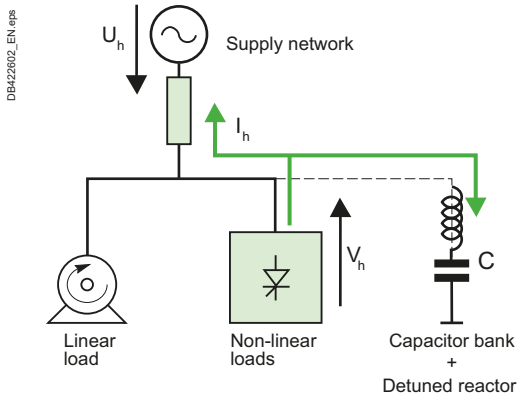


Fig. L31 Simplified circuit diagram

Relative impedance (%)	Tuning order	Tuning frequency @50Hz (Hz)	Tuning frequency @60Hz (Hz)
5.7	4.2	210	250
7	3.8	190	230
14	2.7	135	160

Fig. L32 Correspondance between relative impedance, tuning order and tuning frequency

In this arrangement, the presence of the reactor increases the fundamental frequency voltage (50 or 60Hz) across the capacitor.

This feature is taken into account by using capacitors which are designed with a rated voltage U_N higher than the network service voltage U_S , as shown on the following table.

Capacitor Rated Voltage U_N (V)		Network Service Voltage U_S (V)				
		50 Hz		60 Hz		
Relative Impedance (%)	5.7	400	690	400	480	600
	7	480	830	480	575	690
	14	480		480		

Fig. L33 Typical values of capacitor rated voltage

L24

9 The effects of harmonics

Summary

Practical rules are suggested in **Fig. L34**, for selection of the suitable configuration, depending on the system parameters:

- S_{SC} = 3-phase short-circuit power in kVA at the busbar level
- S_n = sum of the kVA ratings of all transformers supplying (i.e. directly connected to) the busbar
- G_h = sum of the kVA ratings of all harmonic-generating devices (static converters, inverters, variable speed drives, etc.) connected to the busbar. If the ratings of some of these devices are quoted in kW only, assume an average power factor of 0.7 to obtain the kVA ratings

General rule (for any size of transformer)			
$G_h \leq S_{SC}/120$	$S_{SC}/120 < G_h \leq S_{SC}/70$	$S_{SC}/70 < G_h \leq S_{SC}/30$	$G_h > S_{SC}/30$
Standard capacitors	Heavy Duty capacitors or capacitors with voltage rating increased by 10%	Heavy Duty capacitors or capacitors with voltage rating increased by 20% + detuned reactor	Harmonic filtering necessary See chapter M "Harmonic management"

Simplified rule (if transformer rating $\geq 2MVA$)			
$G_h \leq 0.1 \times S_n$	$0.1 \times S_n < G_h \leq 0.2 \times S_n$	$0.2 \times S_n < G_h \leq 0.5 \times S_n$	$G_h > 0.5 \times S_n$
Standard capacitors	Heavy Duty capacitors or capacitors with voltage rating increased by 10%	Heavy Duty capacitors or capacitors with voltage rating increased by 20% + detuned reactor	Harmonic filtering necessary See chapter M "Harmonic management"

Fig. L34 Simplified rules

10 Implementation of capacitor banks

10.1 Capacitor elements

Technology

Capacitors at low voltage are dry-type units (i.e. are not impregnated by liquid dielectric) comprising metallised polypropylene self-healing film in the form of a two-film roll.

Self-healing is a process by which the capacitor restores itself in the event of a fault in the dielectric which can happen during high overloads, voltage transients, etc.

When insulation breaks down, a short duration arc is formed (Fig. L35 - top). The intense heat generated by this arc causes the metallization in the vicinity of the arc to vaporise (Fig. L35 - middle).

Simultaneously it re-insulates the electrodes and maintains the operation and integrity of the capacitor (Fig. L35 - bottom).

DB422803_EN_4ppa

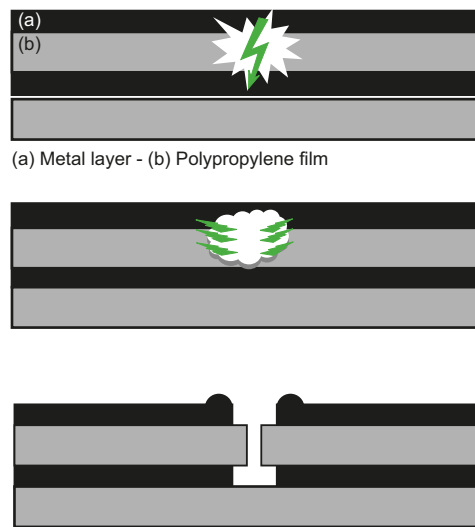


Fig. L35 Illustration of self-healing phenomena

Protection scheme

Capacitors must be associated with overload protection devices (fuses, or circuit breaker, or overload relay + contactor), in order to limit the consequences of over-currents. This may occur in case of overvoltage or high harmonic distortion.

In addition to external protection devices, capacitors are protected by a high-quality system (Pressure Sensitive Disconnecter, also called 'tear-off fuse') which switches off the capacitors if an internal fault occurs. This enables safe disconnection and electrical isolation at the end of the life of the capacitor.

The protection system operates as follows:

- Current levels greater than normal, but insufficient to trigger the over-current protection sometimes occur, e.g. due to a microscopic flow in the dielectric film. Such faults are cleared by self-healing.
- If the leakage current persists (and self-healing repeats), the defect may produce gas by vaporizing of the metallisation at the faulty location. This will gradually build up a pressure within the container. Pressure can only lead to vertical expansion by bending lid outwards. Connecting wires break at intended spots. Capacitor is disconnected irreversibly.

10 Implementation of capacitor banks

DB422604.eps

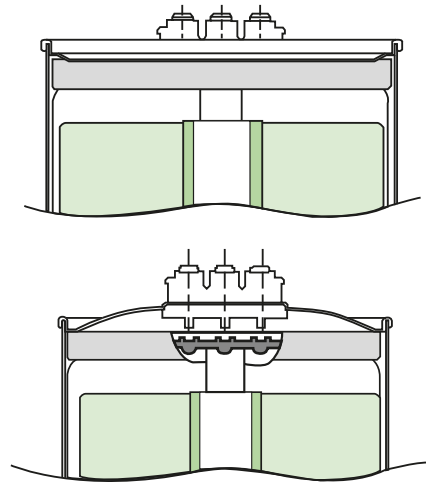


Fig. L36 Cross-section view of a three-phase capacitor after Pressure Sensitive Device operated: bended lid and disconnected wires

Main electrical characteristics, according to IEC standard 60831-1/2: "Shunt power capacitors of the self-healing type for a.c. systems having a rated voltage up to and including 1 000 V".

Electrical characteristics	
Capacitance tolerance	-5 % to +10 % for units and banks up to 100 kvar -5 % to +5 % for units and banks above 100 kvar
Temperature range	Min: from -50 to +5°C Max: from +40 to +55°C
Permissible current overload	1.3 x I _N
Permissible voltage overload	1.1 x U _N , 8 h every 24 h 1.15 x U _N , 30 min every 24 h 1.2 x U _N , 5min 1.3 x U _N , 1min 2.15 x U _N for 10 s (type test)
Discharging unit	to 75 V in 3 min or less

Fig. L37 Main characteristics of capacitors according to IEC 60831-1/2

L27

10.2 Choice of protection, control devices and connecting cables

The choice of upstream cables, protection and control devices depends on the current loading.

For capacitors, the current is a function of:

- The system voltage (fundamental and harmonics),
- The power rating.

The rated current I_N of a 3-phase capacitor bank is equal to:

$$I_N = \frac{Q}{\sqrt{3} \cdot U} \quad \text{with:}$$

- Q: power rating (kvar)
- U: phase-to-phase voltage (kV)

Overload protection devices have to be implemented and set according to the expected harmonic distortion. The following table (see **Fig. L38**) summarizes the harmonic voltages to be considered in the different configurations, and the corresponding maximum overload factor I_{MP}/I_N. (I_{MP} = maximum permissible current)

10 Implementation of capacitor banks

Configuration	Harmonic order					THDu max (%)	I _{mp} /I _N
	3	5	7	11	13		
Standard capacitors						5	1.5
Heavy Duty capacitors						7	1.8
Capacitors + 5.7% reactor	0.5	5	4	3.5	3	10	1.31
Capacitors + 7% reactor	0.5	6	4	3.5	3	8	1.19
Capacitors + 14% reactor	3	8	7	3.5	3	6	1.12

Fig. L38 Typical permissible overload currents

Short time delay setting of circuit breakers (short-circuit protection) should be set at 10 x I_N in order to be insensitive to inrush current.

Example 1:

50 kvar – 400V – 50 Hz – Standard capacitors

$$I_N = \frac{50}{\sqrt{3} \times 0.4} = 72A$$

Long time delay setting: 1.5 x 72 = 108 A

Short time delay setting: 10 x 72 = 720 A

Example 2:

50 kvar – 400V – 50 Hz – Capacitors + 5.7% detuned reactor

$$I_N = 72A$$

Long time delay setting: 1.31 x 72 = 94 A

Short time delay setting: 10 x 72 = 720 A

Upstream cables

Fig. L39 gives the minimum recommended cross section area of the upstream cable for capacitor banks.

Cables for control

The minimum cross section area of these cables will be 1.5 mm² for 230 V. For the secondary side of the current transformer, the recommended cross section area is ≥ 2.5 mm².

Bank power (kvar)		Copper cross- section (mm ²)	Aluminium cross- section (mm ²)
230V	400V		
5	10	2.5	16
10	20	4	16
15	30	6	16
20	40	10	16
25	50	16	25
30	60	25	35
40	80	35	50
50	100	50	70
60	120	70	95
70	140	95	120
90-100	180	120	185
	200	150	240
120	240	185	2 x 95
150	250	240	2 x 120
	300	2 x 95	2 x 150
180-210	360	2 x 120	2 x 185
245	420	2 x 150	2 x 240
280	480	2 x 185	2 x 300
315	540	2 x 240	3 x 185
350	600	2 x 300	3 x 240
385	660	3 x 150	3 x 240
420	720	3 x 185	3 x 300

[a] Minimum cross-section not allowing for any correction factors (installation mode, temperature, etc.). The calculations were made for single-pole cables laid in open air at 30 °C.

Fig. L39 Cross-section of cables connecting medium and high power capacitor banks [a]

10 Implementation of capacitor banks

Voltage transients

High-frequency voltage and current transients occur when switching a capacitor bank into service. The maximum voltage peak does not exceed (in the absence of harmonics) twice the peak value of the rated voltage when switching uncharged capacitors.

In the case of a capacitor being already charged at the instant of switch closure, however, the voltage transient can reach a maximum value approaching 3 times the normal rated peak value.

This maximum condition occurs only if:

- The existing voltage at the capacitor is equal to the peak value of rated voltage, and
- The switch contacts close at the instant of peak supply voltage, and
- The polarity of the power-supply voltage is opposite to that of the charged capacitor

In such a situation, the current transient will be at its maximum possible value, viz: Twice that of its maximum when closing on to an initially uncharged capacitor, as previously noted.

For any other values of voltage and polarity on the pre-charged capacitor, the transient peaks of voltage and current will be less than those mentioned above. In the particular case of peak rated voltage on the capacitor having the same polarity as that of the supply voltage, and closing the switch at the instant of supply-voltage peak, there would be no voltage or current transients.

Where automatic switching of stepped banks of capacitors is considered, therefore, care must be taken to ensure that a section of capacitors about to be energized is fully discharged.

The discharge delay time may be shortened, if necessary, by using discharge resistors of a lower resistance value.

L - Power Factor Correction

L30

1	The problem: why is it necessary to manage harmonics?	M2
2	Definition and origin of harmonics	M3
	2.1 Definition.....	M3
	2.2 Origin of harmonics	M5
3	Essential indicators of harmonic distortion and measurement principles	M7
	3.1 Power factor	M7
	3.2 Crest factor.....	M8
	3.4 r.m.s. value.....	M9
	3.5 Usefulness of the various indicators.....	M9
4	Harmonic measurement in electrical networks	M10
	4.1 Procedures for harmonic measurement.....	M10
	4.2 Harmonic measurement devices.....	M11
	4.3 Which harmonic orders must be monitored and mitigated?.....	M12
5	Main effects of harmonics in electrical installations	M13
	5.1 Resonance	M13
	5.2 Increased losses	M13
	5.3 Overload of equipment.....	M15
	5.4 Disturbances affecting sensitive loads	M18
	5.5 Economic impact	M19
6	Standards	M20
7	Solutions to mitigate harmonics	M21
	7.1 Basic solutions	M21
	7.2 Harmonic filtering.....	M22
	7.3 The method	M24

1 The problem: why is it necessary to manage harmonics?

Harmonic disturbances

Harmonics flowing in distribution networks represent disturbances in the flow of electricity. The quality of electrical power is deteriorated, and the efficiency of the system is decreased.

Here are the main risks linked to harmonics:

- Overload of distribution networks due to the increase of r.m.s. currents,
- Overload of neutral conductors, which current can exceed the phase currents,
- Overload, vibration and premature ageing of generators, transformers and motors as well as increased transformer hum,
- Overload and premature ageing of Power Factor Correction capacitors,
- Distortion of the supply voltage that can disturb sensitive loads,
- Disturbance in communication networks and telephone lines.

Economic impact of disturbances

All these disturbances have an economic impact:

- Premature ageing of equipment means it must be replaced sooner, unless oversized right from the start,
- Overload on the distribution network means higher equipment rating, increased subscribed power level for the industrial customer, and increased power losses,
- Unexpected current distortion can lead to nuisance tripping and production halt.

A necessary concern for the design and management of electrical installations

Harmonics are the result of the always expanding number of power electronic devices. They have become abundant today because of their capabilities for precise process control and energy saving benefits. Typical examples are Variable Speed Drives in the Industry, and Compact Fluorescent Lamps in commercial and residential areas.

International standards have been published in order to help the designers of equipment and installations. Harmonic emission limits have been set, so that no unexpected and negative impact of harmonics should be encountered. In parallel to a better understanding of effects, solutions have been developed by the Industry. Harmonic consideration is now a full part of the design of electrical installations.

2 Definition and origin of harmonics

2.1 Definition

The presence of harmonics in electrical systems means that current and voltage are distorted and deviate from sinusoidal waveforms.

Harmonic currents are caused by non-linear loads connected to the distribution system. A load is said to be non-linear when the current it draws does not have the same waveform as the supply voltage. The flow of harmonic currents through system impedances in turn creates voltage harmonics, which distort the supply voltage.

On **Fig. M1** are presented typical current waveforms for single-phase (top) and three-phase non-linear loads (bottom).

DB426/0 eps

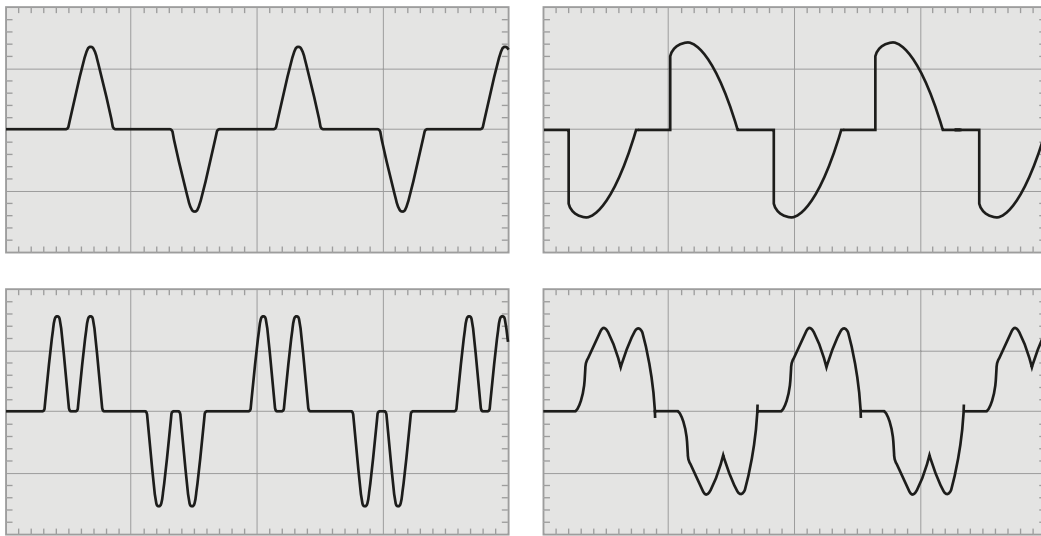


Fig. M1 Examples of distorted current waveforms

The Fourier theorem states that all non-sinusoidal periodic functions can be represented as the sum of terms (i.e. a series) made up of:

- A sinusoidal term at the fundamental frequency,
- Sinusoidal terms (harmonics) whose frequencies are whole multiples of the fundamental frequency,
- A DC component, where applicable.

The harmonic of order h (commonly referred to as simply the h^{th} harmonic) in a signal is the sinusoidal component with a frequency that is h times the fundamental frequency.

The equation for the harmonic expansion of a periodic function $y(t)$ is presented below:

$$y(t) = Y_0 + \sum_{h=1}^{h=\infty} Y_h \sqrt{2} \sin(h\omega t - \varphi_h)$$

where:

- Y_0 : value of the DC component, generally zero and considered as such hereinafter,
- Y_h : r.m.s. value of the harmonic of order h ,
- ω : angular frequency of the fundamental frequency,.
- φ_h : displacement of the harmonic component at $t = 0$.

2 Definition and origin of harmonics

Fig. M2 shows an example of a current wave affected by harmonic distortion on a 50Hz electrical distribution system. The distorted signal is the sum of a number of superimposed harmonics:

- The value of the fundamental frequency (or first order harmonic) is 50 Hz,
- The 3rd order harmonic has a frequency of 150 Hz,
- The 5th order harmonic has a frequency of 250 Hz,
- Etc.

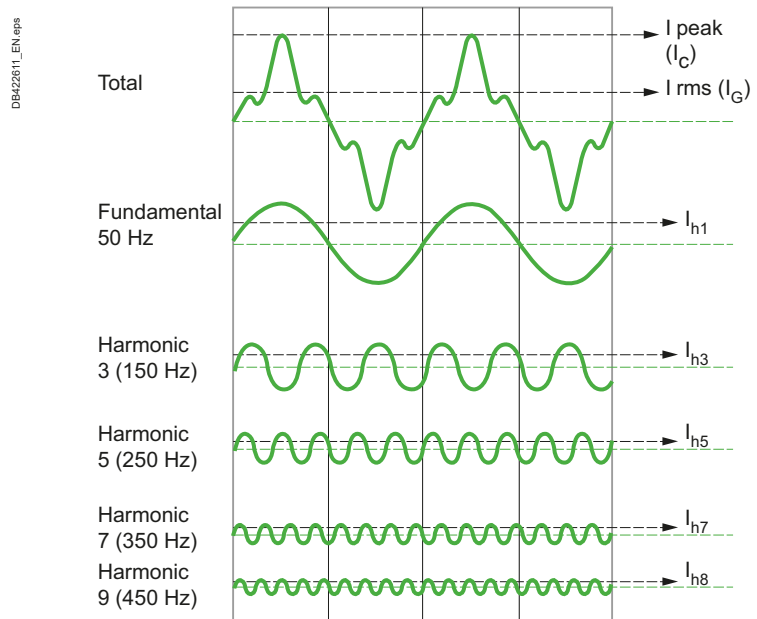


Fig. M2 Example of a current containing harmonics and expansion of the overall current into its harmonic orders 1 (fundamental), 3, 5, 7 and 9

Individual harmonic component (or harmonic component of order h)

The individual harmonic component is defined as the percentage of harmonics for order h with respect to the fundamental. Particularly:

$$u_h(\%) = 100 \frac{U_h}{U_1} \quad \text{for harmonic voltages}$$

$$i_h(\%) = 100 \frac{I_h}{I_1} \quad \text{for harmonic currents}$$

Total Harmonic Distortion (THD)

The Total Harmonic Distortion (THD) is an indicator of the distortion of a signal. It is widely used in Electrical Engineering and Harmonic management in particular.

For a signal y, the THD is defined as:

$$THD = \sqrt{\sum_{h=2}^{h=H} \left(\frac{Y_h}{Y_1} \right)^2} = \frac{\sqrt{Y_2^2 + Y_3^2 + \dots + Y_H^2}}{Y_1}$$

THD is the ratio of the r.m.s. value of all the harmonic components of the signal y, to the fundamental Y_1 .

H is generally taken equal to 50, but can be limited in most cases to 25.

Note that THD can exceed 1 and is generally expressed as a percentage.

2 Definition and origin of harmonics

Current or voltage THD

For current harmonics, the equation is:

$$THD_i = \sqrt{\sum_{h=2}^{h=H} \left(\frac{I_h}{I_1}\right)^2}$$

By introducing the total r.m.s value of the current: $I_{rms} = \sqrt{\sum_{h=1}^{h=H} I_h^2}$ we obtain the following relation:

$$THD_i = \sqrt{\left(\frac{I_{rms}}{I_1}\right)^2 - 1} \quad \text{equivalent to:} \quad I_{rms} = I_1 \sqrt{1 + THD_i^2}$$

Example: for $THD_i = 40\%$, we get:

$$I_{rms} = I_1 \sqrt{1 + (0.4)^2} = I_1 \sqrt{1 + 0.16} \approx I_1 \times 1.08$$

For voltage harmonics, the equation is:

$$THD_u = \sqrt{\sum_{h=2}^{h=H} \left(\frac{U_h}{U_1}\right)^2}$$

2.2 Origin of harmonics

Harmonic currents

Equipment comprising power electronics circuits are typical non-linear loads and generate harmonic currents. Such loads are increasingly frequent in all industrial, commercial and residential installations and their percentage in overall electrical consumption is growing steadily.

Examples include:

- Industrial equipment (welding machines, arc and induction furnaces, battery chargers),
- Variable Speed Drives for AC or DC motors ^[1],
- Uninterruptible Power Supplies,
- Office equipment (PCs, printers, servers, etc.),
- Household appliances (TV sets, microwave ovens, fluorescent lighting, light dimmers).

Harmonic voltages

In order to understand the origin of harmonic voltages, let's consider the simplified diagram on **Fig. M3**.

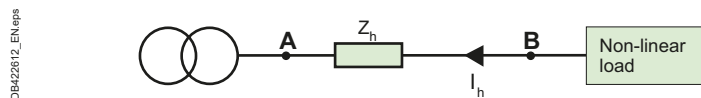


Fig. M3 Single-line diagram showing the impedance of the supply circuit for a non-linear load

[1] to know more about harmonics mitigation related to Variable Speed Drives, please refer to our Schneider Electric White Paper "[Choose the best harmonic mitigation solution for your drive](#)"

2 Definition and origin of harmonics

The reactance of a conductor increases as a function of the frequency of the current flowing through the conductor. For each harmonic current (order h), there is therefore an impedance Z_h in the supply circuit.

The total system can be split into different circuits:

- One circuit representing the flow of current at the fundamental frequency,
- One circuit representing the flow of harmonic currents.

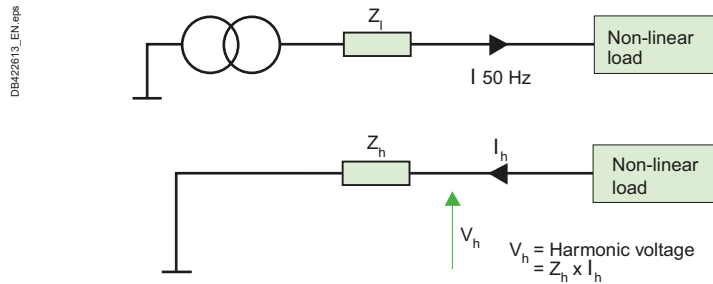


Fig. M4 Split of circuit into fundamental and harmonic circuits

When the harmonic current of order h flows through impedance Z_h , it creates a harmonic voltage $U_{h,h}$, where $U_{h,h} = Z_h \times I_h$ (by Ohm's law).

The voltage at point B is therefore distorted. All devices supplied via point B receive a distorted voltage.

For a given harmonic current, the voltage distortion is proportional to the impedance in the distribution network.

Flow of harmonic currents in distribution networks

The non-linear loads can be considered to inject the harmonic currents upstream into the distribution network, towards the source. The harmonic currents generated by the different loads sum up at the busbar level creating the harmonic distortion. Because of the different technologies of loads, harmonic currents of the same order are generally not in phase. This diversity effect results in a partial summation.

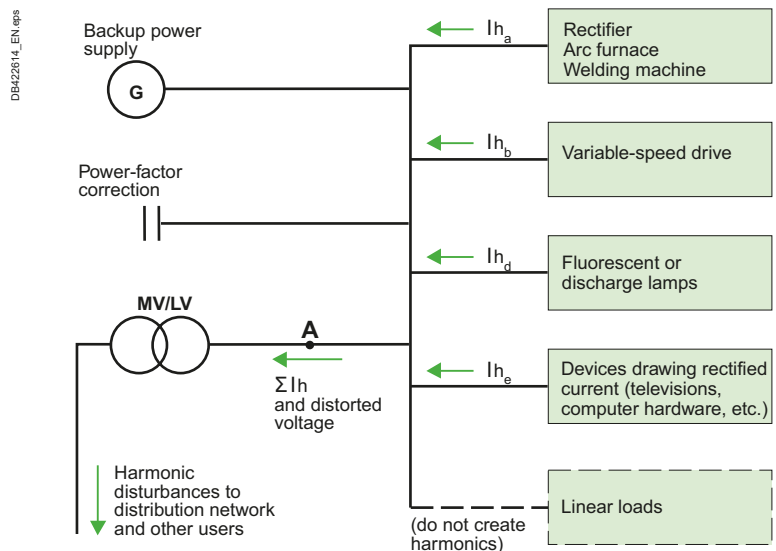


Fig. M5 Flow of harmonic currents in a distribution network

3 Essential indicators of harmonic distortion and measurement principles

A number of indicators are used to quantify and evaluate the harmonic distortion in current and voltage waveforms, namely:

- Power factor
- Crest factor
- Harmonic spectrum
- R.m.s. value

These indicators are indispensable in determining any necessary corrective action.

3.1 Power factor

The power factor λ is the ratio of the active power P (kW) to the apparent power S (kVA). See Chapter L.

$$\lambda = \frac{P(\text{kW})}{S(\text{kVA})}$$

The Power Factor must not be mixed-up with the Displacement Power Factor ($\cos\phi$), relative to fundamental signals only.

As the apparent power is calculated from the r.m.s. values, the Power Factor integrates voltage and current distortion.

When the voltage is sinusoidal or virtually sinusoidal ($\text{THD}_u \sim 0$), it may be said that the active power is only a function of the fundamental current. Then:

$$P \approx P_1 = U_1 I_1 \cos\phi$$

Consequently:
$$\lambda = \frac{P}{S} = \frac{U_1 I_1 \cos\phi}{U_1 I_{\text{rms}}}$$

As:
$$\frac{I_1}{I_{\text{rms}}} = \frac{1}{\sqrt{1 + \text{THD}_i^2}} \quad (\text{see 2.1}), \text{ hence: } \lambda \approx \frac{\cos\phi}{\sqrt{1 + \text{THD}_i^2}}$$

Fig. M6 shows a graph of $\lambda/\cos\phi$ as a function of THD_i , for $\text{THD}_u \sim 0$.

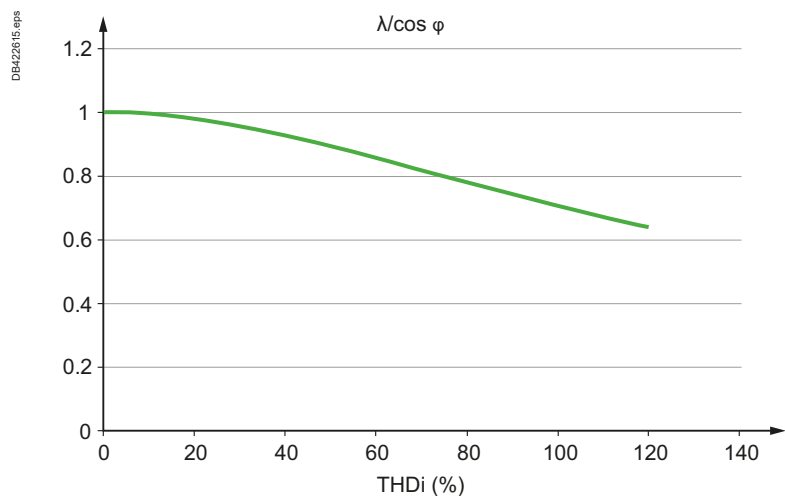


Fig. M6 Variation of $\lambda/\cos\phi$ as a function of THD_i , for $\text{THD}_u \sim 0$

3 Essential indicators of harmonic distortion and measurement principles

3.2 Crest factor

The crest factor is the ratio between the value of the peak current or voltage (I_M or U_M) and its r.m.s. value.

■ For a sinusoidal signal, the crest factor is therefore equal to $\sqrt{2}$.

■ For a non-sinusoidal signal, the crest factor can be either greater than or less than $\sqrt{2}$.

The crest factor for the current drawn by non-linear loads is commonly much higher than $\sqrt{2}$. It is generally between 1.5 and 2 and can even reach 5 in critical cases.

A high crest factor signals high current peaks which, when detected by protection devices, can cause nuisance tripping.

Examples:

Fig. M7 represents the current absorbed by a compact fluorescent lamp.

$I_{r.m.s.}$:	0.16A
I_M :	0.6A
THD_i :	145%
Crest factor:	3.75

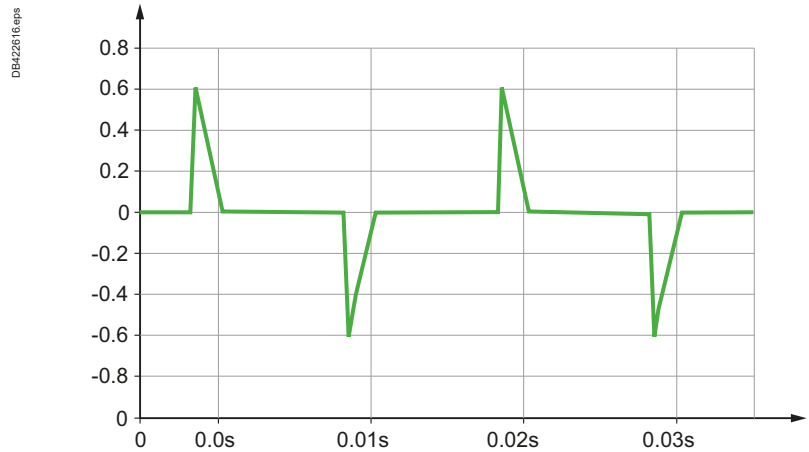


Fig. M7 Typical current waveform of a compact fluorescent lamp

Fig. M8 represents the voltage supplying non-linear loads through a high impedance line, with a typical "flat top" distorted waveform.

$V_{r.m.s.}$:	500V
V_M :	670V
THD_u :	6.2%
Crest factor:	1.34

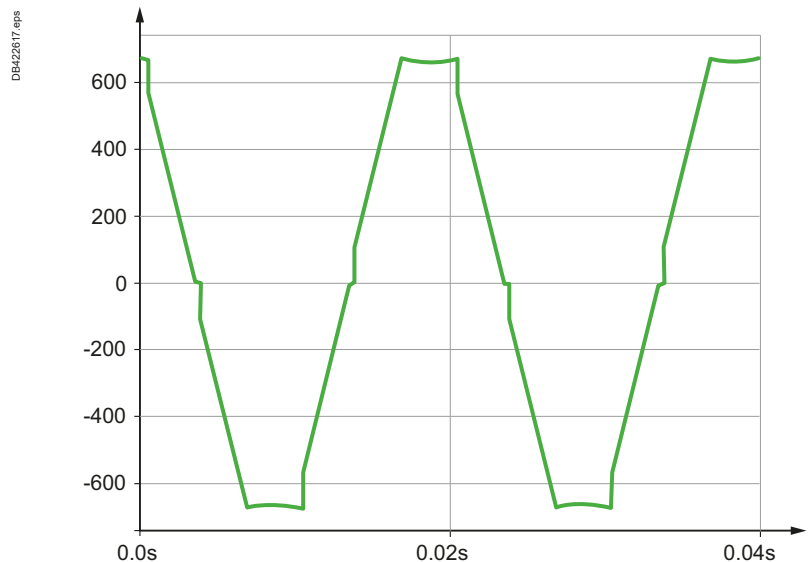


Fig. M8 Typical voltage waveform in case of high impedance line supplying non-linear loads

3 Essential indicators of harmonic distortion and measurement principles

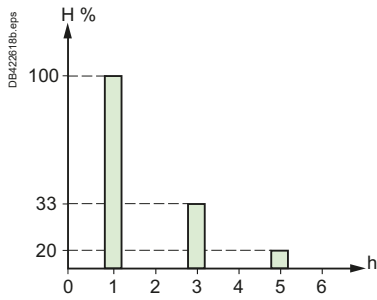
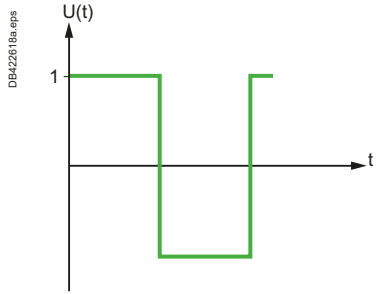


Fig. M9 Harmonic spectrum for a rectangular signal U(t)

3.3 Harmonic spectrum

The harmonic spectrum is the representation of the amplitude of each harmonic order with respect to its frequency.

Fig. M9 shows an example of harmonic spectrum for a rectangular signal.

Each type of device causing harmonics draws a particular form of current, with a particular harmonic content. This characteristic can be displayed by using the harmonic spectrum.

3.4 r.m.s. value

The r.m.s. value of voltage and current can be calculated as a function of the r.m.s. value of the various harmonic components:

$$I_{rms} = \sqrt{\sum_{h=1}^H I_h^2} = \sqrt{I_1^2 + I_2^2 + \dots + I_H^2}$$

$$V_{rms} = \sqrt{\sum_{h=1}^H V_h^2} = \sqrt{V_1^2 + V_2^2 + \dots + V_H^2}$$

3.5 Usefulness of the various indicators

THD_u is an indicator of the distortion of the voltage wave. Below are given indicative values of THD_u and the corresponding consequences in an installation:

- ≤ 5%: normal situation, no risk of malfunctions,
- 5 to 8%: significant harmonic distortion, some malfunctions are possible,
- ≥ 8%: major harmonic distortion, malfunctions are probable. In-depth analysis and the installation of mitigation devices are required.

THD_i is an indicator of the distortion of the current wave. The current distortion can be different in the different parts of an installation. The origin of possible disturbances can be detected by measuring the THD_i of different circuits.

Below are given indicative values of THD_i and the corresponding phenomena for a whole installation:

- ≤ 10%: normal situation, no risk of malfunctions,
- 10 to 50%: significant harmonic distortion with a risk of temperature rise and the resulting need to oversize cables and sources,
- ≥ 50%: major harmonic distortion, malfunctions are probable. In-depth analysis and the installation of mitigation devices are required.

Power factor λ is used to determine the rating for the different devices of the installation.

Crest factor is used to characterise the aptitude of a generator (or UPS) to supply high instantaneous currents. For example, computer equipment draws highly distorted current for which the crest factor can reach 3 to 5.

Harmonic spectrum provides a different representation of electrical signals and can be used to evaluate their distortion.

4 Harmonic measurement in electrical networks

4.1 Procedures for harmonic measurement

Harmonic measurements are carried out on industrial or commercial sites:

- Preventively, to obtain an overall idea on distribution-network status (network mapping),
- In view of corrective action, to determine the origin of a disturbance and determine the solutions required to eliminate it,
- To check the validity of a solution (following modifications in the distribution network to check the reduction of harmonic disturbances)

The harmonic indicators can be measured:

- By an expert present on the site for a limited period of time (one day), giving precise, but limited perception,
- By instrumentation devices installed and operating for a significant period of time (at least one week) giving a reliable overview of the situation,
- Or by devices permanently installed in the distribution network, allowing a follow-up of Power Quality.

One-shot or corrective actions

This kind of action is carried-out in case of observed disturbances, for which harmonics are suspected. In order to determine the origin of the disturbances, measurements of current and voltage are performed:

- At the supply source level,
- On the busbars of the main distribution switchboard (or on the MV busbars),
- On each outgoing circuit in the main distribution switchboard.

For accurate results, it is necessary to know the precise operating conditions of the installation and particularly the status of the capacitor banks (operating or not, number of connected steps).

The results of measurement will help the analysis in order to:

- Determine any necessary derating of equipment in the installation, or
- Quantify any necessary harmonic protection and filtering systems to be installed in the distribution network, or
- Check the compliance of the electrical installation with the applicable standards or Utility regulations (maximum permissible harmonic emission).

Long-term or preventive actions

For a number of reasons, the installation of permanent measurement devices in the distribution network is very valuable.

- The presence of an expert on site is limited in time and it is not always possible to observe all the possible situations. Only a number of measurements at different points in the installation and over a sufficiently long period (one week to a month) provide an overall view of operation and take into account all the situations that can occur following:

- Fluctuations in the supply source,
- Variations in the operation of the installation,
- The addition of new equipment in the installation.

- Measurement devices installed in the distribution network prepare and facilitate the diagnosis of the experts, thus reducing the number and duration of their visits..

- Permanent measurement devices detect any new disturbances arising following the installation of new equipment, the implementation of new operating modes or fluctuations in the supply network.

- For an overall evaluation of network status (preventive analysis), this avoids:

- Renting of measurement equipment,
- Calling in experts,
- Having to connect and disconnect the measurement equipment. For the overall evaluation of network status, the analysis on the main low-voltage distribution switchboards (MLVS) can often be carried out by the incoming device and/or the measurement devices equipping each outgoing circuit,

- For corrective actions, it is possible to:

- Determine the operating conditions at the time of the incident,
- Draw-up a map of the distribution network and evaluate the implemented solution.

The diagnosis may be improved by the use of additional dedicated equipment in case of specific problem.

M10

4 Harmonic measurement in electrical networks

4.2 Harmonic measurement devices

Measurement devices provide instantaneous and average information concerning harmonics. Instantaneous values are used for analysis of disturbances linked to harmonics. Average values are used for Power Quality assessment.

The most recent measurement devices are designed referring to IEC standard 61000-4-7: "Electromagnetic compatibility (EMC) – Part 4-7: Testing and measurement techniques – General guide on harmonics and interharmonics measurements and instrumentation, for power supply systems and equipment connected thereto".

The supplied values include:

- The harmonic spectrum of currents and voltages (amplitudes and percentage of the fundamental),
- The THD for current and voltage,
- For specific analysis: the phase angle between harmonic voltage and current of the same order and the phase of the harmonics with respect to a common reference (e.g. the fundamental voltage).

Average values are indicators of the long-term Power Quality. Typical and relevant statistical data are for example measures averaged by periods of 10 minutes, during observation periods of 1 week.

In order to meet the Power Quality objectives, 95% of the measured values should be less than specified values.

Fig. M10 gives the maximum harmonic voltage in order to meet the requirements of standard EN50160: "Voltage characteristics of electricity supplied by public distribution networks", for Low and Medium Voltage.

Odd harmonics Not multiples of 3		Odd harmonics Multiples of 3		Even harmonic	
Order h	Relative amplitude Uh: %	Order h	Relative amplitude Uh: %	Order h	Relative amplitude Uh: %
5	6	3	5	2	2
7	5	9	1.5	4	1
11	3.5	15	0.5	6...24	0.5
13	3	21	0.5		
17	2				
19	1.5				
23	1.5				
25	1.5				

Fig. M10 Values of individual harmonic voltages at the supply terminals for orders up to 25 given in percent of the fundamental voltage U1

Portable instruments

The traditional observation and measurement methods include:

- Oscilloscope

An initial indication on the distortion affecting a signal can be obtained by viewing the current or the voltage on an oscilloscope.

The waveform, when it diverges from a sinusoidal, clearly indicates the presence of harmonics. Current and voltage peaks can be observed.

Note, however, that this method does not offer precise quantification of the harmonic components.

- Digital analyser

Only recent digital analysers can determine the values of all the mentioned indicators with sufficient accuracy.

They are using digital technology, specifically a high performance algorithm called Fast Fourier Transform (FFT). Current or voltage signals are digitized and the algorithm is applied on data relative to time windows of 10 (50 Hz systems) or 12 periods (for 60 Hz systems) of the power frequency.

The amplitude and phase of harmonics up to the 40th or 50th order are calculated, depending on the class of measurement.

Processing of the successive values calculated using the FFT (smoothing, classification, statistics) can be carried out by the measurement device or by external software.

PB116000.eps

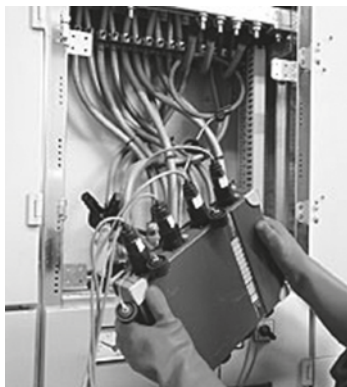


Fig. M11 Implementation of a digital Power Quality recorder within a cabinet

4 Harmonic measurement in electrical networks

Functions of digital analysers

- Calculate the values of the harmonic indicators (power factor, crest factor, individual harmonic amplitude, THD)
- In multi-channel analysers, supply virtually in real time the simultaneous spectral decomposition of the currents and voltages
- Carry out various complementary functions (corrections, statistical detection, measurement management, display, communication, etc.)
- Storage of data

Fixed instruments

Panel instrumentation provides continuous information to the Manager of the electrical installation. Data can be accessible through dedicated power monitoring devices or through the digital trip units of circuit breakers.

PB116164-46.eps



PB116801.eps



PB116047-4.eps



PB116804.eps



Fig. M12 Example of Power and Energy meter

4.3 Which harmonic orders must be monitored and mitigated?

The most significant harmonic orders in three-phase distribution networks are the odd orders (3, 5, 7, 9, 11, 13 ...)

Triplen harmonics (order multiple of 3) are present only in three-phase, four-wire systems, when single phase loads are connected between phase and neutral.

Utilities are mainly focusing on low harmonic orders (5, 7, 11, and 13).

Generally speaking, harmonic conditioning of the lowest orders (up to 13) is sufficient. More comprehensive conditioning takes into account harmonic orders up to 25.

Harmonic amplitudes normally decrease as the frequency increases. Sufficiently accurate measurements are obtained by measuring harmonics up to order 30.

Fig. M13 Example of electronic trip units of circuit breakers providing harmonic related information

M12

5 Main effects of harmonics in electrical installations

5.1 Resonance

The simultaneous use of capacitive and inductive devices in distribution networks may result in parallel or series resonance.

The origin of the resonance is the very high or very low impedance values at the busbar level, at different frequencies. The variations in impedance modify the current and voltage in the distribution network.

Here, only parallel resonance phenomena, the most common, will be discussed.

Consider the following simplified diagram (see Fig. M14) representing an installation made up of:

- A supply transformer,
- Linear loads
- Non-linear loads drawing harmonic currents
- Power factor correction capacitors

For harmonic analysis, the equivalent diagram is shown on Fig. M15 where:

L_s = Supply inductance (upstream network + transformer + line)

C = Capacitance of the power factor correction capacitors

R = Resistance of the linear loads

I_h = Harmonic current

By neglecting R , the impedance Z is calculated by a simplified formula:

$$Z = \frac{jL_s\omega}{1-L_sC\omega^2}$$

with: ω = pulsation of harmonic currents

Resonance occurs when the denominator ($1-L_sC\omega^2$) tends toward zero. The corresponding frequency is called the resonance frequency of the circuit. At that frequency, impedance is at its maximum and high amounts of harmonic voltages appear because of the circulation of harmonic currents. This results in major voltage distortion. The voltage distortion is accompanied, in the L_s+C circuit, by the flow of harmonic currents greater than those drawn by the loads, as illustrated on Fig. M16.

The distribution network and the power factor correction capacitors are subjected to high harmonic currents and the resulting risk of overloads. To avoid resonance, anti-harmonic reactors can be installed in series with the capacitors. Fig. M17

DB422619_EN.eps

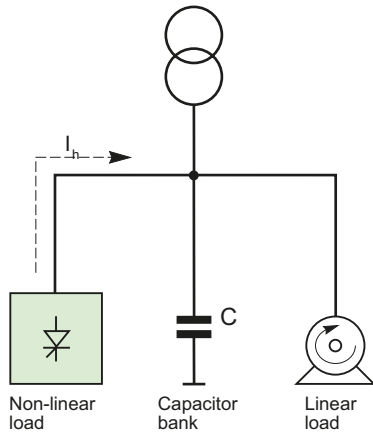


Fig. M14 Diagram of an installation

DB422620.eps

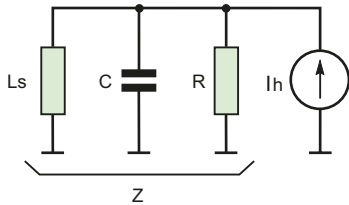


Fig. M15 Equivalent diagram of the installation shown in Figure M14

DB422601_EN.eps

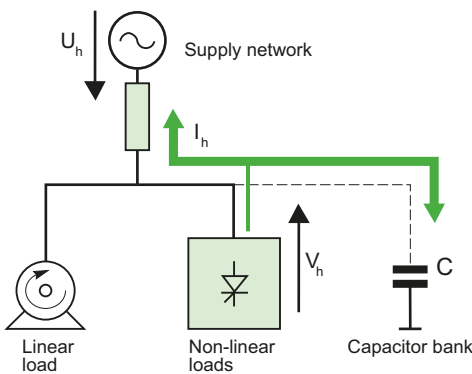


Fig. M16 Illustration of parallel resonance

DB422602_EN.eps

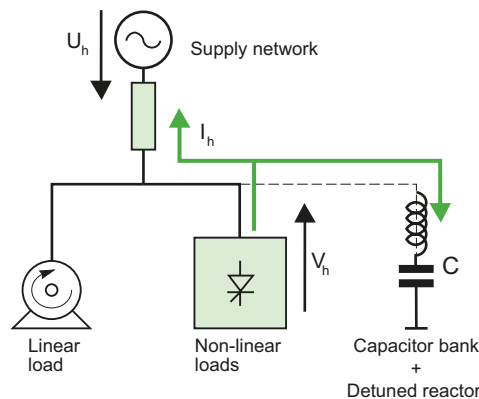


Fig. M17 Reduced circulation of harmonic currents with detuned reactors

5.2 Increased losses

Losses in conductors

The active power transmitted to a load is a function of the fundamental component I_1 of the current.

When the current drawn by the load contains harmonics, the r.m.s. value of the current, $I_{r.m.s.}$, is greater than the fundamental I_1 .

5 Main effects of harmonics in electrical installations

The definition of THD_i being:

$$THD_i = \sqrt{\left(\frac{I_{r.m.s.}}{I_1}\right)^2 - 1}$$

it may be deduced that: $I_{r.m.s.} = I_1 \cdot \sqrt{1 + THD_i^2}$

Fig. M18 shows, as a function of the harmonic distortion:

- The increase in the r.m.s. current $I_{r.m.s.}$ for a load drawing a given fundamental current
- The increase in Joule losses, not taking into account the skin effect (the reference point in the graph is 1 for $I_{r.m.s.}$ and Joules losses, the case when there are no harmonics)

The harmonic currents cause an increase of the Joule losses in all conductors in which they flow and additional temperature rise in transformers, switchgear, cables, etc.

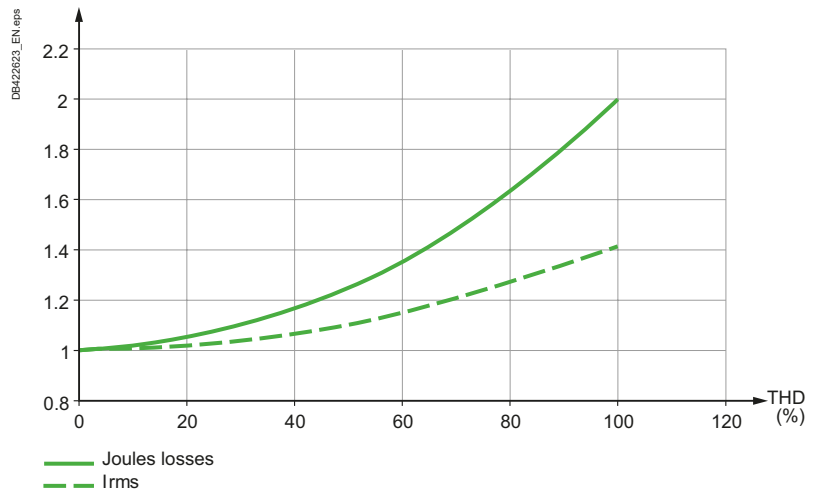


Fig. M18 Increase in rms current and Joule losses as a function of the THD

Losses in asynchronous machines

The harmonic voltages (order h) supplied to asynchronous machines cause the flow of currents in the rotor with frequencies higher than 50 Hz that are the origin of additional losses.

Orders of magnitude

- A virtually rectangular supply voltage causes a 20% increase in losses
- A supply voltage with harmonics $u_5 = 8\%$ (of U_1 , the fundamental voltage), $u_7 = 5\%$, $u_{11} = 3\%$, $u_{13} = 1\%$, i.e. total harmonic distortion THD_u equal to 10%, results in additional losses of 6%

Losses in transformers

Harmonic currents flowing in transformers cause an increase in the “copper” losses due to the Joule effect and increased “iron” losses due to eddy currents. The harmonic voltages are responsible for “iron” losses due to hysteresis.

It is generally considered that losses in windings increase as the square of the THD_i and that core losses increase linearly with the THD_u .

In Utility distribution transformers, where distortion levels are limited, losses increase between 10 and 15%.

Losses in capacitors

The harmonic voltages applied to capacitors cause the flow of currents proportional to the frequency of the harmonics. These currents cause additional losses.

M14

5 Main effects of harmonics in electrical installations

Example

A supply voltage has the following harmonics:

- Fundamental voltage U_1 ,
- harmonic voltages $u_5 = 8\%$ (of U_1),
- $u_7 = 5\%$,
- $u_{11} = 3\%$,
- $u_{13} = 1\%$,

i.e. total harmonic distortion THD_u equal to 10%. The amperage of the current is multiplied by 1.19. Joule losses are multiplied by $(1.19)^2$, i.e. 1.4.

5.3 Overload of equipment

Generators

Generators supplying non-linear loads must be derated due to the additional losses caused by harmonic currents.

The level of derating is approximately 10% for a generator where the overall load is made up of 30% of non-linear loads. It is therefore necessary to oversize the generator, in order to supply the same active power to loads.

Uninterruptible power systems (UPS)

The current drawn by computer systems has a very high crest factor. A UPS sized taking into account exclusively the r.m.s. current may not be capable of supplying the necessary peak current and may be overloaded.

Transformers

- The curve presented below (see Fig. M19) shows the typical derating required for a transformer supplying electronic loads

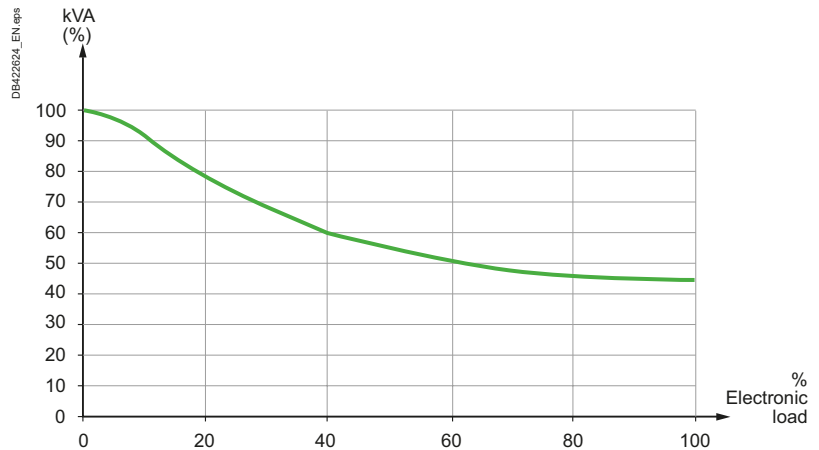


Fig. M19 Derating required for a transformer supplying electronic loads

Example: If the transformer supplies an overall load comprising 40% of electronic loads, it must be derated by 40%.

- Standard UTE C15-112 provides a derating factor for transformers as a function of the harmonic currents.

$$k = \frac{1}{\sqrt{1 + 0.1 \left(\sum_{h=2}^{40} h^{1.6} T_h^2 \right)}}$$

$$T_h = \frac{I_h}{I_1}$$

Typical values:

- Current with a rectangular waveform (1/h spectrum): $k = 0.86$
- Frequency-converter current ($THD \approx 50\%$): $k = 0.80$

M15

5 Main effects of harmonics in electrical installations

Asynchronous machines

Standard IEC60034-1 ("Rotating electrical machines – Rating and performance") defines a weighted harmonic factor (Harmonic voltage factor) for which the equation and maximum value are provided below.

$$HVF = \sqrt{\sum_{h=2}^{13} \frac{U_h}{h^2}} \leq 0.02$$

Example

A supply voltage has a fundamental voltage U_1 and harmonic voltages $u_3 = 2\%$ of U_1 , $u_5 = 3\%$, $u_7 = 1\%$. The THD_u is 3.7% and the HVF is 0.018. The HVF value is very close to the maximum value above which the machine must be derated.

Practically speaking, asynchronous machines must be supplied with a voltage having a THD_u not exceeding 10%.

Capacitors

According to IEC 60831-1 standard ("Shunt power capacitors of the self-healing type for a.c. systems having a rated voltage up to and including 1 000 V – Part 1: General – Performance, testing and rating – Safety requirements – Guide for installation"), the r.m.s. current flowing in the capacitors must not exceed 1.3 times the rated current.

Using the example mentioned above, the fundamental voltage U_1 , harmonic voltages $u_5 = 8\%$ (of U_1), $u_7 = 5\%$, $u_{11} = 3\%$, $u_{13} = 1\%$, i.e. total harmonic distortion THD_u equal to 10%, the result is

$I_{r.m.s.}/I_1 = 1.19$, at the rated voltage. For a voltage equal to 1.1 times the rated voltage, the current limit

$I_{r.m.s.}/I_1 = 1.3$ is reached and it is necessary to resize the capacitors.

Neutral conductors

Consider a system made up of a balanced three-phase source and three identical single-phase loads connected between the phases and the neutral (see Fig. M20).

Fig. M21 shows an example of the currents flowing in the three phases and the resulting current in the neutral conductor.

In this example, the current in the neutral conductor has a rms value that is higher than the rms value of the current in a phase by a factor equal to the square root of 3.

DB422625_EN.eps

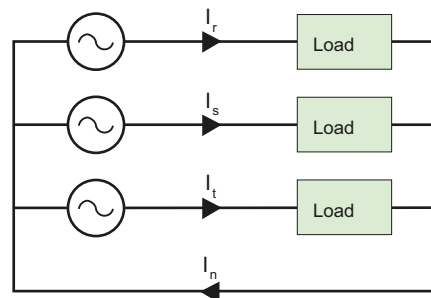


Fig. M20 Flow of currents in the various conductors connected to a three-phase source

M16

5 Main effects of harmonics in electrical installations

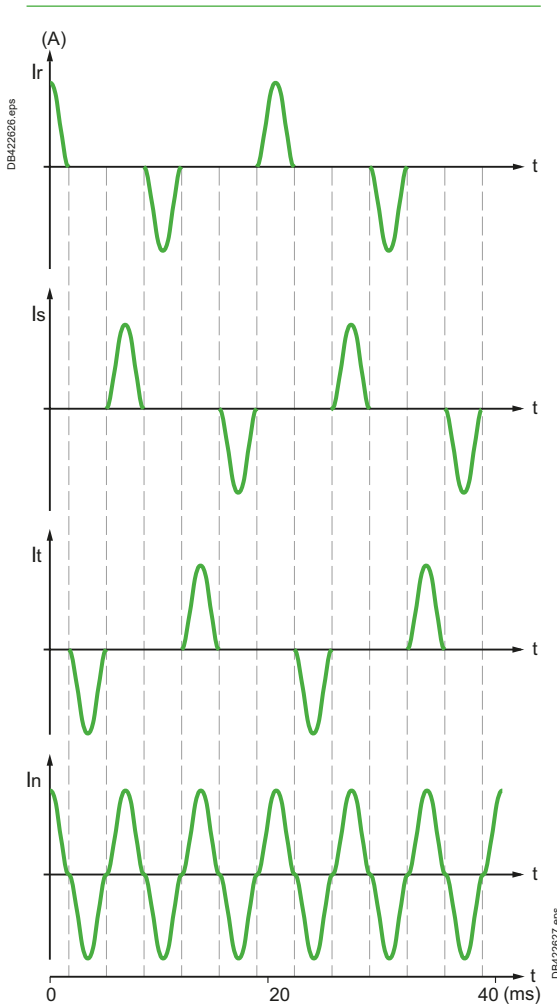


Fig. M21 Example of the currents flowing in the various conductors connected to a three-phase load ($I_n = I_r + I_s + I_t$)

The neutral conductor must therefore be sized accordingly.

The current in the neutral may therefore exceed the current in each phase in installation such as those with a large number of single-phase devices (IT equipment, fluorescent lighting, etc.). This is the case in office buildings, computer centers, Internet Data Centers, call centers, banks, shopping centers, retail lighting zones, etc.

This is not a general situation, due to the fact that power is being supplied simultaneously to linear and/or three-phase loads (heating, ventilation, incandescent lighting, etc.), which do not generate third order harmonic currents. However, particular care must be taken when dimensioning the cross-sectional areas of neutral conductors when designing new installations or when modifying them in the event of a change in the loads being supplied with power.

A simplified approach can be used to estimate the loading of the neutral conductor.

For balanced loads, the current in the neutral I_N is very close to 3 times the 3rd harmonic current of the phase current (I_3), i.e.:

$$I_N \approx 3 \cdot I_3$$

This can be expressed as:

$$I_N \approx 3 \cdot i_3 \cdot I_1$$

For low distortion factor values, the r.m.s. value of the current is similar to the r.m.s. value of the fundamental, therefore:

$$I_N \approx 3 \cdot i_3 \cdot I_L$$

And:

$$I_N / I_L \approx 3 \cdot i_3 (\%)$$

This equation simply links the overloading of the neutral (I_N / I_L) to the third harmonic current ratio.

In particular, it shows that when this ratio reaches 33%, the current in the neutral conductor is equal to the current in the phases. Whatever the distortion value, it has been possible to use simulations to obtain a more precise law, which is illustrated in Fig. M22.

The third harmonic ratio has an impact on the current in the neutral and therefore on the capacity of all components in an installation:

- Distribution panels
- Protection and distribution devices
- Cables and trunking systems

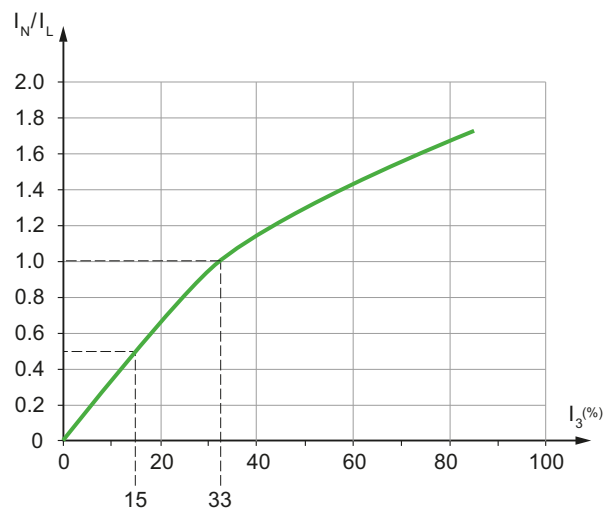


Fig. M22 Loading of the neutral conductor based on the 3rd harmonic ratio

According to the estimated third harmonic ratio, there are three possible scenarios: ratio below 15%, between 15 and 33% or above 33%.

5 Main effects of harmonics in electrical installations

Third harmonic ratio below 15% ($i_3 \leq 15\%$):

The neutral conductor is considered not to be carrying current. The cross-sectional area of the phase conductors is determined solely by the current in the phases. The cross-sectional area of the neutral conductor may be smaller than the cross-sectional area of the phases if the cross sectional area is greater than 16 mm² (copper) or 25 mm² (aluminum).

Protection of the neutral is not obligatory, unless its cross-sectional area is smaller than that of the phases.

Third harmonic ratio between 15 and 33% ($15 < i_3 \leq 33\%$), or in the absence of any information about harmonic ratios:

The neutral conductor is considered to be carrying current.

The operating current of the multi-pole trunking must be reduced by a factor of 0.84 (or, conversely, select trunking with an operating current equal to the current calculated, divided by 0.84).

The cross-sectional area of the neutral MUST be equal to the cross-sectional area of the phases.

Protection of the neutral is not necessary.

Third harmonic ratio greater than 33% ($i_3 > 33\%$)

This rare case represents a particularly high harmonic ratio, generating the circulation of a current in the neutral, which is greater than the current in the phases. Precautions therefore have to be taken when dimensioning the neutral conductor.

Generally, the operating current of the phase conductors must be reduced by a factor of 0.84 (or, conversely, select trunking with an operating current equal to the current calculated, divided by 0.84). In addition, the operating current of the neutral conductor must be equal to 1.45 times the operating current of the phase conductors (i.e. 1.45/0.84 times the phase current calculated, therefore approximately 1.73 times the phase current calculated).

The recommended method is to use multi-pole trunking in which the cross-sectional area of the neutral is equal to the cross-sectional area of the phases. The current in the neutral conductor is therefore a key factor in determining the cross sectional area of the conductors. Protection of the neutral is not necessary, although it should be protected if there is any doubt in terms of the loading of the neutral conductor.

This approach is common in final distribution, where multi-pole cables have identical cross sectional areas for the phases and for neutral.

With busbar trunking systems (busways), precise knowledge of the temperature rises caused by harmonic currents enables a less conservative approach to be adopted. The rating of a busbar trunking system can be selected directly as a function of the neutral current calculated.

For more details, see chapter E paragraph 2.3 "Harmonic currents in the selection of busbar trunking systems (busways)" and "Cahier Technique ECT212: The neutral: A live and unique conductor"

5.4 Disturbances affecting sensitive loads

Effects of distortion in the supply voltage

Distortion of the supply voltage can disturb the operation of sensitive devices:

- Regulation devices (temperature)
- Computer hardware
- Control and monitoring devices (protection relays)

Distortion of telephone signals

Harmonics cause disturbances in control circuits (low current levels). The level of distortion depends on the distance that the power and control cables run in parallel, the distance between the cables and the frequency of the harmonics.

M18

5 Main effects of harmonics in electrical installations

5.5 Economic impact

Energy losses

Harmonics cause additional losses (Joule effect) in conductors and equipment.

Higher subscription costs

The presence of harmonic currents can require a higher subscribed power level and consequently higher costs. What is more, Utilities will be increasingly inclined to charge customers for major sources of harmonics.

Oversizing of equipment

- Derating of power sources (generators, transformers and UPSs) means they must be oversized
- Conductors must be sized taking into account the flow of harmonic currents. In addition, due the skin effect, the resistance of these conductors increases with frequency. To avoid excessive losses due to the Joule effect, it is necessary to oversize conductors
- Flow of harmonics in the neutral conductor means that it must be oversized as well

Reduced service life of equipment

When the level of distortion THD_u of the supply voltage reaches 10%, the duration of service life of equipment is significantly reduced. The reduction has been estimated at:

- 32.5% for single-phase machines
- 18% for three-phase machines
- 5% for transformers

To maintain the service lives corresponding to the rated load, equipment must be oversized.

Nuisance tripping and installation shutdown

Circuit breakers in the installation are subjected to current peaks caused by harmonics. These current peaks may cause nuisance tripping of old technology units, with the resulting production losses, as well as the costs corresponding to the time required to start the installation up again.

Examples

Given the economic consequences for the installations mentioned below, it was necessary to install harmonic filters.

Computer centre for an insurance company

In this centre, nuisance tripping of a circuit breaker was calculated to have cost 100 k€ per hour of down time.

Pharmaceutical laboratory

Harmonics caused the failure of a generator set and the interruption of a long duration test on a new medication. The consequences were a loss estimated at 17 M€.

Metallurgy factory

A set of induction furnaces caused the overload and destruction of three transformers ranging from 1500 to 2500 kVA over a single year. The cost of the interruptions in production were estimated at 20 k€ per hour.

Factory producing garden furniture

The failure of variable-speed drives resulted in production shutdowns estimated at 10 k€ per hour.

6 Standards

Harmonic emissions are subject to various standards and regulations:

- Compatibility standards for distribution networks
- Emissions standards applying to the equipment causing harmonics
- Recommendations issued by Utilities and applicable to installations

In view of rapidly attenuating the effects of harmonics, a triple system of standards and regulations is currently in force based on the documents listed below.

Standards governing compatibility between distribution networks and products

These standards determine the necessary compatibility between distribution networks and products:

- The harmonics caused by a device must not disturb the distribution network beyond certain limits
- Each device must be capable of operating normally in the presence of disturbances up to specific levels.
- Standard IEC 61000-2-2 is applicable for public low-voltage power supply systems.
- Standard IEC 61000-2-4 is applicable for LV and MV industrial installations.

Standards governing the quality of distribution networks

- Standard EN 50160 stipulates the characteristics of electricity supplied by public distribution networks.
- Standard IEEE 519 presents a joint approach between Utilities and customers to limit the impact of non-linear loads. What is more, Utilities encourage preventive action in view of reducing the deterioration of power quality, temperature rise and the reduction of power factor. They will be increasingly inclined to charge customers for major sources of harmonics.

Standards governing equipment

- Standard IEC 61000-3-2 for low-voltage equipment with rated current under 16 A.
- Standard IEC 61000-3-12 for low-voltage equipment with rated current higher than 16 A and lower than 75 A.

Maximum permissible harmonic levels

International studies have collected data resulting in an estimation of typical harmonic contents often encountered in electrical distribution networks.

Fig. M23 presents the levels that, in the opinion of many Utilities, should not be exceeded.

		LV	MV	HV
Odd harmonics non-multiples of 3	5	6	5	2
	7	5	4	2
	11	3.5	3	1.5
	13	3	2.5	1.5
	17 ≤ h ≤ 49	$2.27 \frac{17}{h} - 0.27$	$1.9 \frac{17}{h} - 0.2$	$1.2 \frac{17}{h}$
Odd harmonics multiples of 3	3	5	4	2
	9	1.5	1.2	1
	15	0.4	0.3	0.3
	21	0.3	0.2	0.2
	21 < h ≤ 45	0.2	0.2	0.2
Even harmonics	2	2	1.8	1.4
	4	1	1	0.8
	6	0.5	0.5	0.4
	8	0.5	0.5	0.4
	10 ≤ h ≤ 50	$0.25 \frac{10}{h} + 0.25$	$0.25 \frac{10}{h} + 0.22$	$0.19 \frac{10}{h} + 0.16$
THD _u	8	6.5	3	

Fig. M23 Maximum admissible harmonic voltages and distortion (%)

M20

7 Solutions to mitigate harmonics

There are three different types of solutions to attenuate harmonics:

- Modifications in the installation
- Special devices in the supply system
- Filtering

7.1 Basic solutions

To limit the propagation of harmonics in the distribution network, different solutions are available and should be taken into account particularly when designing a new installation.

Position the non-linear loads upstream in the system

Overall harmonic disturbances increase as the short-circuit power decreases.

All economic considerations aside, it is preferable to connect the non-linear loads as far upstream as possible (see Fig. M24).

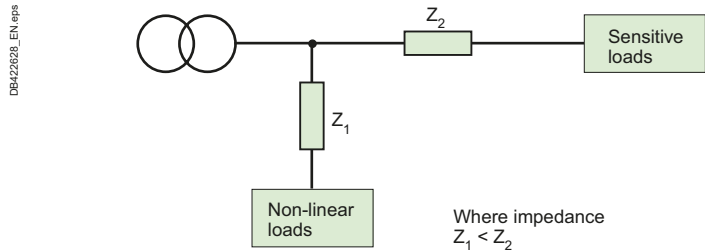


Fig. M24 Non-linear loads positioned as far upstream as possible (recommended layout)

Group the non-linear loads

When preparing the single-line diagram, the non-linear devices should be separated from the others (see Fig. M25). The two groups of devices should be supplied by different sets of busbars.

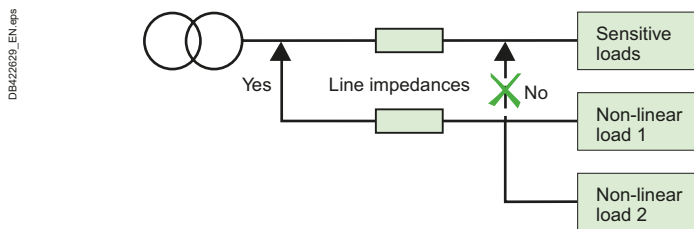


Fig. M25 Grouping of non-linear loads and connection as far upstream as possible (recommended layout)

M21

Create separate sources

In attempting to limit harmonics, an additional improvement can be obtained by creating a source via a separate transformer as indicated in the Fig. M26.

The disadvantage is the increase in the cost of the installation.

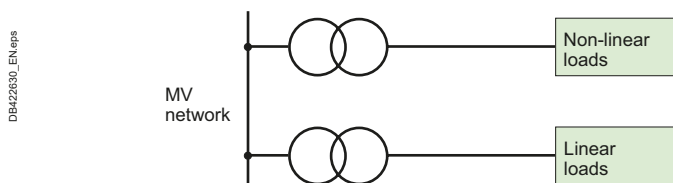


Fig. M26 Supply of non-linear loads via a separate transformer

7 Solutions to mitigate harmonics

Transformers with special connections

Different transformer connections can eliminate certain harmonic orders, as indicated in the examples below:

- A Dyd connection suppresses 5th and 7th harmonics (see Fig. M27)
- A Dy connection suppresses the 3rd harmonic
- A DZ 5 connection suppresses the 5th harmonic

DB-422631_eps

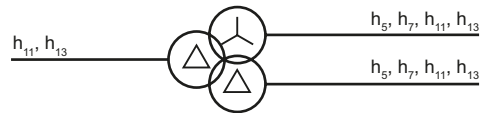


Fig. M27 A Dyd transformer blocks propagation of the 5th and 7th harmonics to the upstream network

Install reactors

When variable-speed drives are supplied, it is possible to smooth the current by installing line reactors. By increasing the impedance of the supply circuit, the harmonic current is limited.

Installation of harmonic suppression reactors on capacitor banks increases the impedance of the reactor/capacitor combination for high-order harmonics.

This avoids resonance and protects the capacitors.

Select the suitable system earthing arrangement

TNC system

In the TNC system, a single conductor (PEN) provides protection in the event of an earth fault and the flow of unbalance currents.

Under steady-state conditions, the harmonic currents flow in the PEN. Because of the PEN impedance, this results in slight differences in potential (a few volts) between devices that can cause electronic equipment to malfunction.

The TNC system must therefore be reserved for the supply of power circuits at the head of the installation and must not be used to supply sensitive loads.

TNS system

This system is recommended if harmonics are present.

The neutral conductor and the protection conductor PE are completely separate and the potential throughout the distribution network is therefore more uniform.

Practically speaking, asynchronous machines must be supplied with a voltage having a THD_u not exceeding 10%.

7.2 Harmonic filtering

In cases where the preventive action presented above is insufficient, it is necessary to equip the installation with filtering systems.

There are three types of filters:

- Passive
- Active
- Hybrid

Passive filters

Typical applications

- Industrial installations with a set of non-linear loads representing more than 500 kVA (variable-speed drives, UPSs, rectifiers, etc.)
- Installations requiring power-factor correction
- Installations where voltage distortion must be reduced to avoid disturbing sensitive loads
- Installations where current distortion must be reduced to avoid overloads

Operating principle

An LC circuit, tuned to each harmonic order to be filtered, is installed in parallel with the non-linear load (see Fig. M28). This bypass circuit absorbs the harmonics, thus avoiding their flow in the distribution network.

Generally speaking, the passive filter is tuned to a harmonic order close to the order to be eliminated. Several parallel-connected branches of filters can be used if a significant reduction in the distortion of a number of harmonic orders is required.

M22

DB-422632_EN_eps

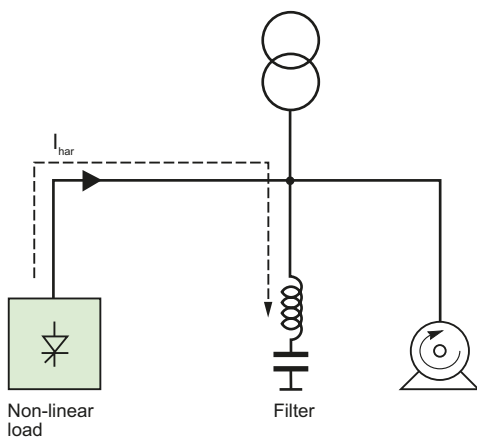


Fig. M28 Operating principle of a passive filter

7 Solutions to mitigate harmonics

DB422833_EN.eps

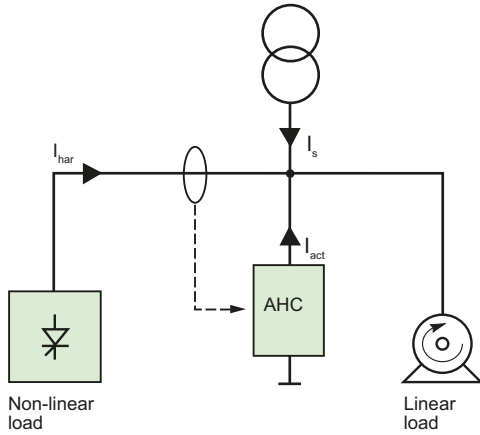


Fig. M29 Operating principle of an active filter

Active filters (active harmonic conditioner)

Typical applications

- Commercial installations with a set of non-linear loads representing less than 500 kVA (variable-speed drives, UPSs, office equipment, etc.)
- Installations where current distortion must be reduced to avoid overloads.

Operating principle

These systems, comprising power electronics and installed in **series or parallel** with the non-linear load, compensate the harmonic current or voltage drawn by the load. **Fig. M29** shows a parallel-connected active harmonic conditioner (AHC) compensating the harmonic current ($I_{har} = -I_{act}$).

The AHC injects in opposite phase the harmonics drawn by the non-linear load, such that the line current I_s remains sinusoidal.

Hybrid filters

Typical applications

- Industrial installations with a set of non-linear loads representing more than 500 kVA (variable-speed drives, UPSs, rectifiers, etc.)
- Installations requiring power-factor correction
- Installations where voltage distortion must be reduced to avoid disturbing sensitive loads
- Installations where current distortion must be reduced to avoid overloads
- Installations where strict limits on harmonic emissions must be met

Operating principle

Passive and active filters are combined in a single system to constitute a hybrid filter (see **Fig. M30**). This new filtering solution offers the advantages of both types of filters and covers a wide range of power and performance levels.

DB422834_EN.eps

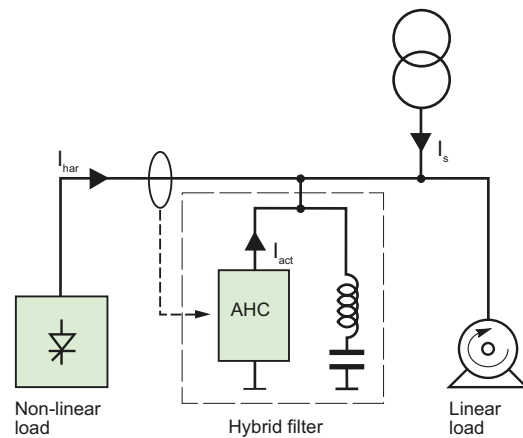


Fig. M30 Operating principle of a hybrid filter

7 Solutions to mitigate harmonics

PB116305 eps



Fig. M31 Example of MV passive filter equipment

Selection criteria

Passive filter (see Fig. M31)

It offers both power-factor correction and high current-filtering capacity. Passive filters also reduce the harmonic voltages in installations where the supply voltage is disturbed. If the level of reactive power supplied is high, it is advised to turn off the passive filter at times when the percent load is low.

Preliminary studies for a filter must take into account the possible presence of a power factor correction capacitor bank which may have to be eliminated.

Active harmonic conditioners (see Fig. M32)

They filter harmonics over a wide range of frequencies and can adapt to any type of load. On the other hand, power ratings are limited.

Hybrid filters

They combine the performance of both active and passive filters.

7.3 The method

The best solution, in both technical and financial terms, is based on the results of an in-depth study.

Harmonic audit of MV and LV networks

By calling on an expert, you are guaranteed that the proposed solution will produce effective results (e.g. a guaranteed maximum THD_U).

A harmonic audit is carried out by an engineer specialised in the disturbances affecting electrical distribution networks and equipped with powerful analysis and simulation equipment and software.

The steps in an audit are the following:

- Measurement of disturbances affecting current and phase-to-phase and phase to neutral voltages at the supply source, the disturbed outgoing circuits and the non-linear loads
- Computer modelling of the phenomena to obtain a precise explanation of the causes and determine the best solutions
- A complete audit report presenting:
 - The current levels of disturbances
 - The maximum permissible levels of disturbances (refer to IEC 61000, IEEE 519, etc.)
- A proposal containing solutions with guaranteed levels of performance
- Finally, implementation of the selected solution, using the necessary means and resources.

PB116306 eps



Fig. M32 Active Harmonic Conditioner (AccuSine range)

The entire audit process should be certified ISO 9002.

M24

Characteristics of particular sources and loads

1	Protection of a LV generator set and the downstream circuits	N2
	1.1 Generator protection.....	N2
	1.2 Downstream LV network protection.....	N5
	1.3 The monitoring functions.....	N5
	1.4 Generator Set parallel-connection.....	N10
2	Uninterruptible Power Supply units (UPS)	N11
	2.1 Availability and quality of electrical power	N11
	2.2 Types of static UPSs.....	N12
	2.3 Batteries	N14
	2.4 System earthing arrangements for installations comprising UPSs.....	N16
	2.5 Choice of protection schemes	N18
	2.6 Installation, connection and sizing of cables	N20
	2.7 The UPSs and their environment	N22
	2.8 Complementary equipment.....	N22
3	Protection of LV/LV transformers	N24
	3.1 Transformer-energizing inrush current	N24
	3.2 Protection for the supply circuit of a LV/LV transformer.....	N24
	3.3 Typical electrical characteristics of LV/LV 50 Hz transformers	N25
	3.4 Protection of LV/LV transformers, using Schneider Electric circuit breakers	N25
4	Lighting circuits	N26
	4.1 The different lamp technologies	N26
	4.2 LED lighting - characteristics	N29
	4.3 LED lighting - constraints and recommendations	N31
	4.4 LED lamps - choice of circuit breaker	N33
	4.5 LED lamps - choice of contactors.....	N34
	4.6 Outdoor LED lighting	N34
	4.7 Other lamp technologies - characteristics.....	N36
	4.8 Other lamp technologies - constraints and recommendations.....	N41
	4.9 Other lamp technologies - choice of contactor according to lamp type.....	N44
	4.10 Other lamp technologies - choice of circuit breaker according to lamp type.....	N48
	4.11 Lighting of "building accessible to the public"	N50
5	Asynchronous motors	N52
	5.1 Motor control systems.....	N52
	5.2 Motor protection functions	N53
	5.3 Motor monitoring	N56
	5.4 Motor starter configurations.....	N57
	5.5 Protection coordination	N59
	5.6 Basic protection scheme: circuit breaker + contactor + thermal relay.....	N59
	5.7 Control and protection switching gear (CPS).....	N60
	5.8 Intelligent Power and Motor Control Centre (IPMCC).....	N62
	5.9 Communication	N64

N - Characteristics of particular sources and loads

1 Protection of a LV generator set and the downstream circuits

Most industrial and large commercial electrical installations include certain important loads for which a power supply must be maintained, in the event that the utility electrical supply fails:

- Either, because safety systems are involved (emergency lighting, automatic fire-protection equipment, smoke dispersal fans, alarms and signalization, and so on...) or
- Because it concerns priority circuits, such as certain equipment, the stoppage of which would entail a loss of production, or the destruction of a machine tool, etc.

One of the current means of maintaining a supply to the so-called "priority" loads, in the event that other sources fail, is to install a diesel generator set connected, via a change-over switch, to an emergency-power standby switchboard, from which the priority services are fed (see Fig. N1).

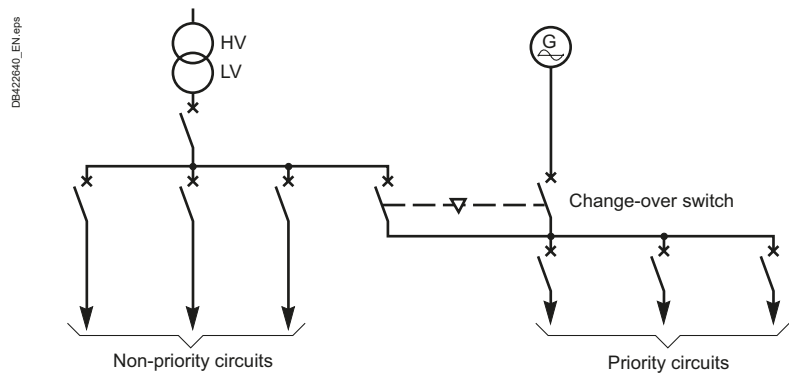


Fig. N1 Example of circuits supplied from a transformer or from an alternator

1.1 Generator protection

Fig. N2 below shows the electrical sizing parameters of a Generator Set. P_n , U_n and I_n are, respectively, the power of the thermal motor, the rated voltage and the rated current of the generator.

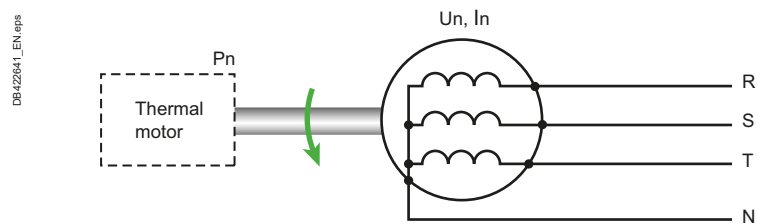


Fig. N2 Block diagram of a generator set

N2

Overload protection

The generator protection curve must be analysed (see Fig. N3).

Standards and requirements of applications can also stipulate specific overload conditions. For example:

I/I_n	t
1.1	> 1 h
1.5	30 s

The setting possibilities of the overload protection devices (or Long Time Delay) will closely follow these requirements.

Note on overloads

■ For economic reasons, the thermal motor of a replacement set may be strictly sized for its nominal power. If there is an active power overload, the diesel motor will stall. The active power balance of the priority loads must take this into account

- A production set must be able to withstand operating overloads:
 - One hour overload
 - One hour 10% overload every 12 hours (Prime Power)

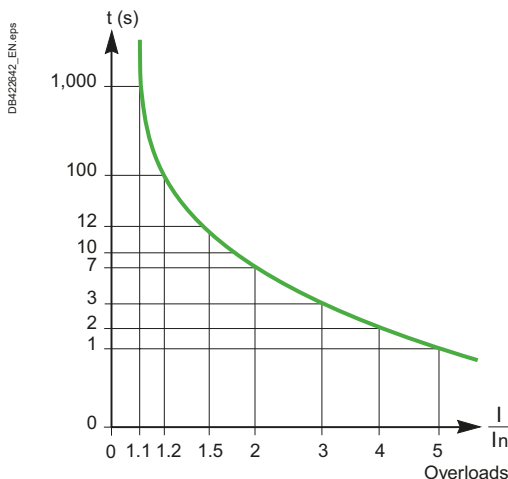


Fig. N3 Example of an overload curve $t = f(I/I_n)$

1 Protection of a LV generator set and the downstream circuits

Short-circuit current protection

Making the short-circuit current

The short-circuit current is the sum:

- Of an aperiodic current
- Of a damped sinusoidal current

The short-circuit current equation shows that it is composed of three successive phases (see Fig. N4).

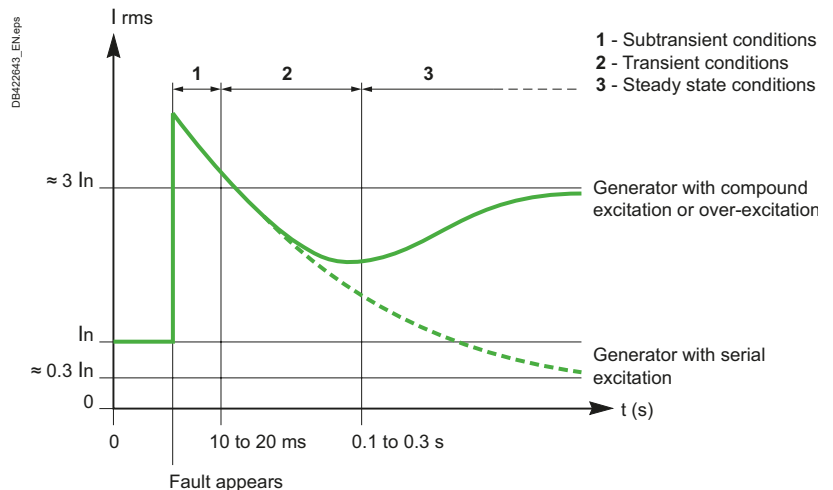


Fig. N4 Short-circuit current level during the 3 phases

■ Subtransient phase

When a short-circuit appears at the terminals of a generator, the current is first made at a relatively high value of around 6 to 12 I_n during the first cycle (0 to 20 ms).

The amplitude of the short-circuit output current is defined by three parameters:

- The subtransient reactance of the generator
- The level of excitation prior to the time of the fault and
- The impedance of the faulty circuit.

The short-circuit impedance of the generator to be considered is the subtransient reactance x''_d expressed in % by the manufacturer. The typical value is 10 to 15%.

We determine the subtransient short-circuit impedance of the generator:

$$X''_d(\text{ohms}) = \frac{U_n^2 x''_d}{100 S} \text{ where } S = \sqrt{3} U_n I_n$$

■ Transient phase

The transient phase is placed 100 to 500 ms after the time of the fault. Starting from the value of the fault current of the subtransient period, the current drops to 1.5 to 2 times the current I_n .

The short-circuit impedance to be considered for this period is the transient reactance x'_d expressed in % by the manufacturer. The typical value is 20 to 30%.

■ Steady state phase

The steady state occurs after 500 ms.

When the fault persists, the output voltage collapses and the exciter regulation seeks to raise this output voltage. The result is a stabilised sustained short-circuit current:

- If generator excitation does not increase during a short-circuit (no field overexcitation) but is maintained at the level preceding the fault, the current stabilises at a value that is given by the synchronous reactance X_d of the generator. The typical value of x_d is greater than 200%. Consequently, the final current will be less than the full-load current of the generator, normally around 0.5 I_n .
- If the generator is equipped with maximum field excitation (field overriding) or with compound excitation, the excitation "surge" voltage will cause the fault current to increase for 10 seconds, normally to 2 to 3 times the full-load current of the generator.

1 Protection of a LV generator set and the downstream circuits

Calculating the short-circuit current

Manufacturers normally specify the impedance values and time constants required for analysis of operation in transient or steady state conditions (see Fig. N5).

(kVA)	75	200	400	800	1,600	2,500
x'd	10.5	10.4	12.9	10.5	18.8	19.1
x'd	21	15.6	19.4	18	33.8	30.2
xd	280	291	358	280	404	292

Fig. N5 Example of impedance table (in %)

Resistances are always negligible compared with reactances. The parameters for the short-circuit current study are:

- Value of the short-circuit current at generator terminals

Short-circuit current amplitude in transient conditions as per CLC/TR 50480^[1] is:

$$I_{sc3} = \frac{U_n}{X'd} \frac{1}{\sqrt{3}} \quad (X'd \text{ in ohms})$$

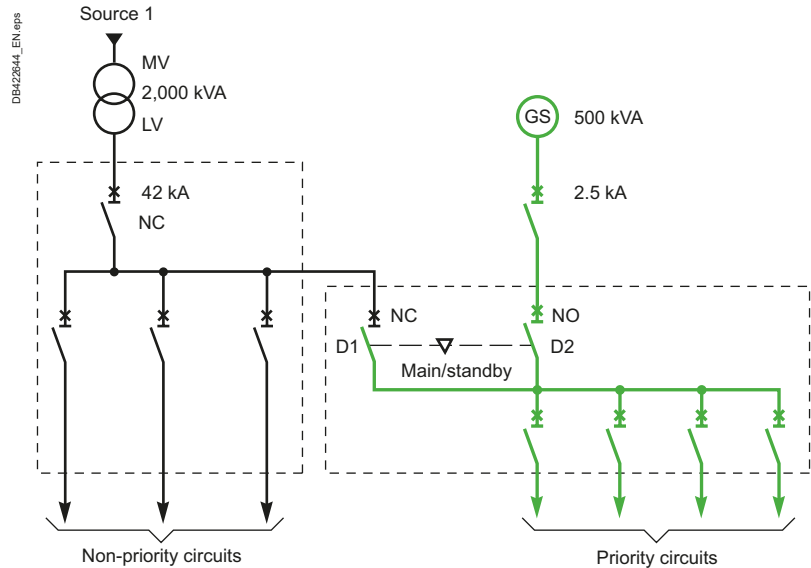
or

$$I_{sc3} = \frac{I_n}{x'd} 100 \quad (x'd \text{ in \%})$$

U_n is the generator phase-to-phase output voltage.

Note: This value can be compared with the short-circuit current at the terminals of a transformer. Thus, for the same power, currents in event of a short-circuit close to a generator will be 5 to 6 times weaker than those that may occur with a transformer (main source).

This difference is accentuated still further by the fact that generator set power is normally less than that of the transformer (see Fig. N6).



NC: Normally closed
NO: Normally open

Fig. N6 Example of a priority services switchboard supplied (in an emergency) from a standby generator set

When the LV network is supplied by the Main source 1 of 2,000 kVA, the short-circuit current is 42 kA at the main LV board busbar. When the LV network is supplied by the Replacement Source 2 of 500 kVA with transient reactance of 30%, the short-circuit current is made at approx. 2.5 kA, i.e. at a value 16 times weaker than with the Main source.

[1] European Technical report CLC/TR 50480 "Determination of cross-sectional area of conductors and selection of protective devices" proposes this type of calculation for cable sizing and protection according to IEC 60364-4-43. Please note that the right method shall be selected according to the objective of the calculation: first peak estimation for electro-dynamic withstand or making capacity, first period rms value for breaking capacity of overcurrent protective device, steady state current for minimum earth fault calculation ...

1 Protection of a LV generator set and the downstream circuits

1.2 Downstream LV network protection

Priority circuit protection

Choice of breaking capacity

This must be systematically checked with the characteristics of the main source (MV/LV transformer).

Setting of the Short Time Delay (STD) tripping current

■ Subdistribution boards

The ratings of the protection devices for the subdistribution and final distribution circuits are always lower than the generator rated current. Consequently, except in special cases, conditions are the same as with transformer supply.

■ Main LV switchboard

□ The sizing of the main feeder protection devices is normally similar to that of the generator set. Setting of the STD must allow for the short-circuit characteristic of the generator set (see "Short-circuit current protection" before)

□ Selectivity of protection devices on the priority feeders must be provided in generator set operation (it can even be compulsory for safety feeders). It is necessary to check proper staggering of STD setting of the protection devices of the main feeders with that of the subdistribution protection devices downstream (normally set for distribution circuits at 10 In).

Note: When operating on the generator set, use of a low sensitivity Residual Current Device enables management of the insulation fault and ensures very simple selectivity.

Safety of people

In the IT (2nd fault) and TN grounding systems, protection of people against indirect contacts is provided by the STD protection of circuit breakers. Their operation on a fault must be ensured, whether the installation is supplied by the main source (Transformer) or by the replacement source (generator set).

Calculating the insulation fault current

Zero-sequence reactance formulated as a% of U₀ by the manufacturer X'₀. The typical value is 8%.

The phase-to-neutral single-phase short-circuit current is given by:

$$I_f = \frac{U_n \sqrt{3}}{2 X'd + X'o}$$

The insulation fault current in the TN system is slightly greater than the three phase fault current. For example, in event of an insulation fault on the system in the previous example, the insulation fault current is equal to 3 kA.

1.3 The monitoring functions

Due to the specific characteristics of the generator and its regulation, the proper operating parameters of the generator set must be monitored when special loads are implemented.

The behaviour of the generator is different from that of the transformer:

- The active power it supplies is optimised for a power factor = 0.8
- At less than power factor 0.8, the generator may, by increased excitation, supply part of the reactive power

Capacitor bank

An off-load generator connected to a capacitor bank may self-excite, consequently increasing its overvoltage.

The capacitor banks used for power factor regulation must therefore be disconnected. This operation can be performed by sending the stopping setpoint to the regulator (if it is connected to the system managing the source switchings) or by opening the circuit breaker supplying the capacitors.

If capacitors continue to be necessary, do not use regulation of the power factor relay in this case (incorrect and over-slow setting).

Motor restart and re-acceleration

A generator can supply at most in transient period a current of between 3 and 5 times its nominal current.

A motor absorbs roughly 6 In for 2 to 20 s during start-up.

1 Protection of a LV generator set and the downstream circuits

If the sum of the motor power is high, simultaneous start-up of loads generates a high pick-up current that can be damaging. A large voltage drop, due to the high value of the generator transient and subtransient reactances will occur (20% to 30%), with a risk of:

- Non-starting of motors
- Temperature rise linked to the prolonged starting time due to the voltage drop
- Tripping of the thermal protection devices

Moreover, all the network and actuators are disturbed by the voltage drop.

Application (see Fig. N7)

A generator supplies a set of motors.

Generator characteristics: $S_n = 130 \text{ kVA}$ at a power factor of 0.8, $U_n = 500 \text{ V}$
 $x'd = 20\%$ (for example) hence $I_{sc} = 750 \text{ A}$.

- If the ΣP_{motors} is 45 kW (45% of generator power)

Calculating voltage drop at start-up:

$\Sigma P_{Motors} = 45 \text{ kW}$, $I_m = 81 \text{ A}$, hence a starting current $I_d = 480 \text{ A}$ for 2 to 20 s.

Voltage drop on the busbar for simultaneous motor starting:

$$\frac{\Delta U}{U} = \left(\frac{I_d - I_n}{I_{sc} - I_n} \right) 100 \text{ in } \%$$

$\Delta U = 55\%$

which is not tolerable for motors (failure to start).

- If the ΣP_{motors} is 20 kW (20% of generator power)

Calculating voltage drop at start-up:

$\Sigma P_{Motors} = 20 \text{ kW}$, $I_m = 35 \text{ A}$, hence a starting current $I_d = 210 \text{ A}$ for 2 to 20 s.

Voltage drop on the busbar:

$$\frac{\Delta U}{U} = \left(\frac{I_d - I_n}{I_{sc} - I_n} \right) 100 \text{ in } \%$$

$\Delta U = 10\%$

which is high but tolerable (depending on the type of loads).

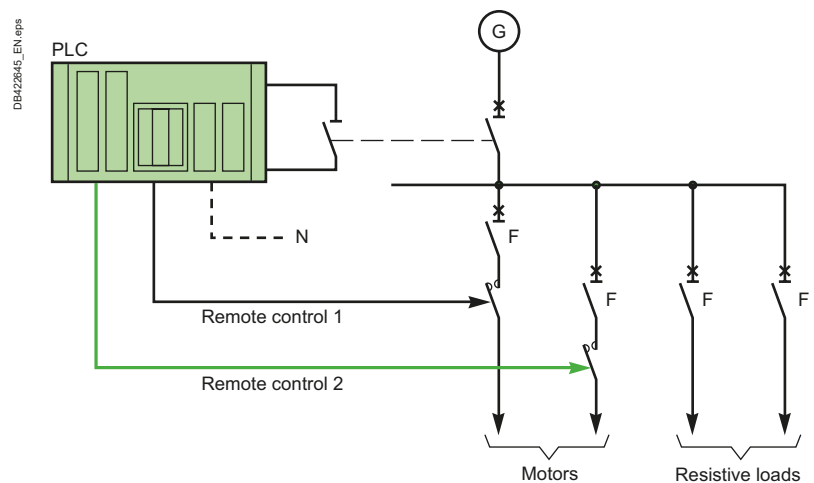


Fig. N7 Restarting of priority motors ($\Sigma P > 1/3 P_n$)

Restarting tips

- If the P_{max} of the largest motor $> \frac{1}{3} P_n$, a soft starter must be installed on this motor
- If $\Sigma P_{motors} > \frac{1}{3} P_n$, motor cascade restarting must be managed by a PLC
- If $\Sigma P_{motors} < \frac{1}{3} P_n$, there are no restarting problems

1 Protection of a LV generator set and the downstream circuits

Non-linear loads – Example of a UPS

Non-linear loads

These are mainly:

- Saturated magnetic circuits
- Discharge lamps, fluorescent lights
- Electronic converters
- Information Technology Equipment: PC, computers, etc.

These loads generate harmonic currents: supplied by a Generator Set, this can create high voltage distortion due to the low short-circuit power of the generator.

Uninterruptible Power Supply (UPS) (see Fig. N8)

The combination of a UPS and generator set is the best solution for ensuring quality power supply with long autonomy for the supply of sensitive loads.

It is also a non-linear load due to the input rectifier. On source switching, the autonomy of the UPS on battery must allow starting and connection of the Generator Set.

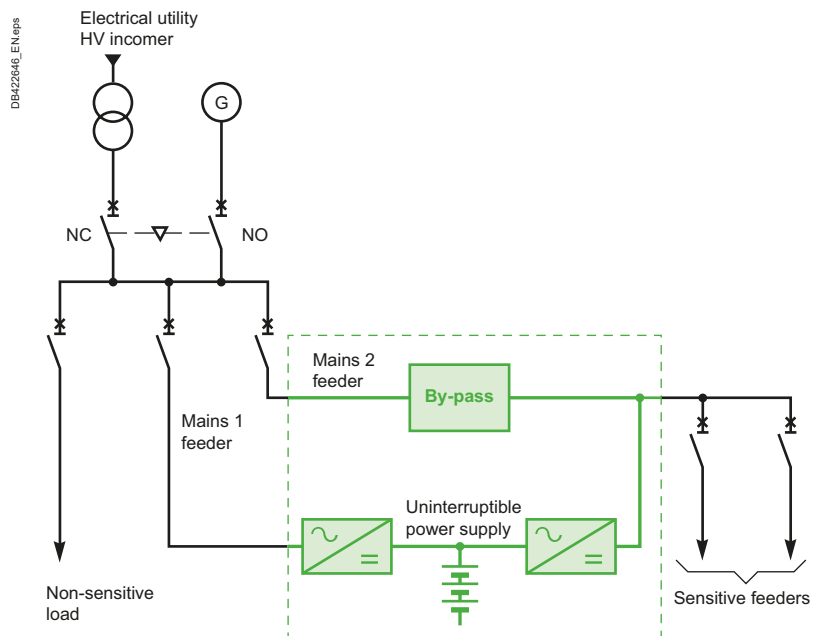


Fig. N8 Generator set- UPS combination for Quality energy

UPS power

UPS inrush power must allow for:

- Nominal power of the downstream loads. This is the sum of the apparent powers P_a absorbed by each application. Furthermore, so as not to oversize the installation, the overload capacities at UPS level must be considered (for example: $1.5 I_n$ for 1 minute and $1.25 I_n$ for 10 minutes)
- The power required to recharge the battery: This current is proportional to the autonomy required for a given power. The sizing S_r of a UPS is given by:

$$S_r = 1.17 \times P_n$$

Fig. N9 next page defines the pick-up currents and protection devices for supplying the rectifier (Mains 1) and the standby mains (Mains 2).

1 Protection of a LV generator set and the downstream circuits

Nominal power Pn (kVA)	Current value (A)	
	Mains 1 with 3Ph battery 400 V - I1	Mains 2 or 3Ph application 400 V - Iu
40	86	60.5
60	123	91
80	158	121
100	198	151
120	240	182
160	317	243
200	395	304
250	493	360
300	590	456
400	793	608
500	990	760
600	1,180	912
800	1,648	1,215

Fig. N9 Pick-up current for supplying the rectifier and standby mains

Generator Set/UPS combination

■ Restarting the Rectifier on a Generator Set

The UPS rectifier can be equipped with a progressive starting of the charger to prevent harmful pick-up currents when installation supply switches to the Generator Set (see Fig. N10).

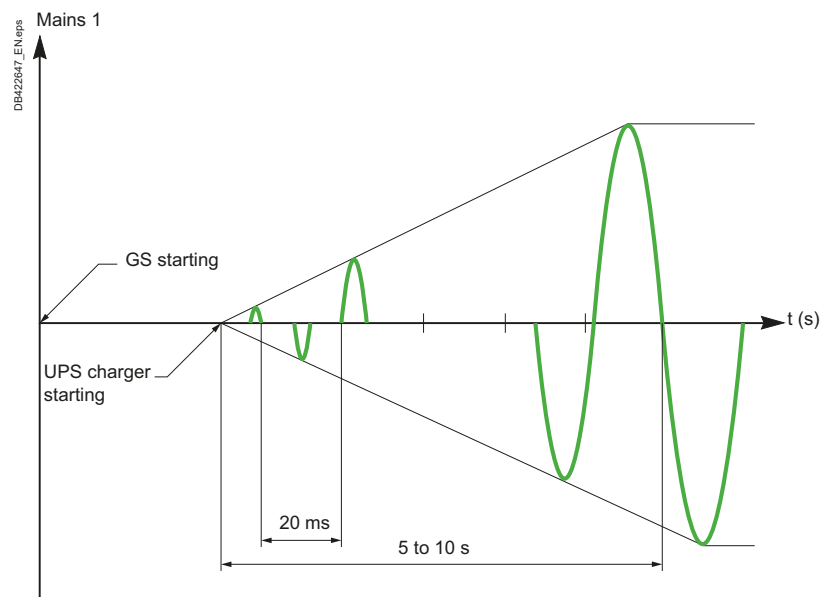


Fig. N10 Progressive starting of a type 2 UPS rectifier

■ Harmonics and voltage distortion

Total voltage distortion T is defined by:

$$\tau(\%) = \frac{\sqrt{\sum U_h^2}}{U_1}$$

where U_h is the harmonic voltage of order h .

This value depends on:

- The harmonic currents generated by the rectifier (proportional to the power S_r of the rectifier)
- The longitudinal subtransient reactance X''_d of the generator
- The power S_g of the generator

We define $U'R_{cc}(\%) = X''_d \frac{S_r}{S_g}$ the generator relative short-circuit voltage, brought to rectifier power, i.e. $t = f(U'R_{cc})$.

1 Protection of a LV generator set and the downstream circuits

Note 1: As subtransient reactance is great, harmonic distortion is normally too high compared with the tolerated value (7 to 8%) for reasonable economic sizing of the generator: use of a suitable filter is an appropriate and cost-effective solution.

Note 2: Harmonic distortion is not harmful for the rectifier but may be harmful for the other loads supplied in parallel with the rectifier.

Application

A chart is used to find the distortion τ as a function of $U'R_{cc}$ (see Fig. N11).

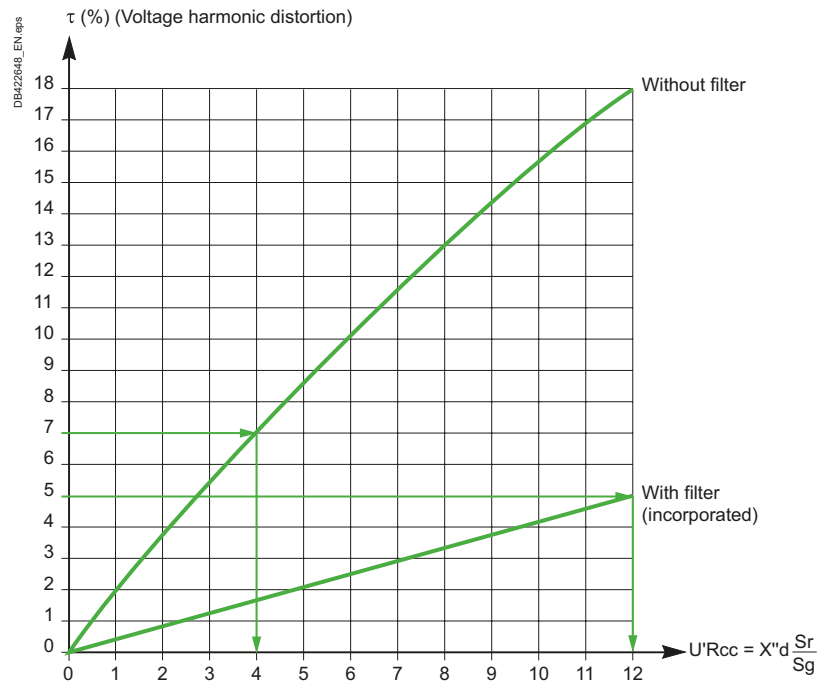


Fig. N11 Chart for calculating harmonic distortion

The chart gives:

- Either τ as a function of $U'R_{cc}$
- Or $U'R_{cc}$ as a function of τ

From which generator set sizing, S_g , is determined.

Example: Generator sizing

- 300 kVA UPS without filter, subtransient reactance of 15%

The power S_r of the rectifier is $S_r = 1.17 \times 300 \text{ kVA} = 351 \text{ kVA}$

For a $\tau < 7\%$, the chart gives $U'R_{cc} = 4\%$, power S_g is:

$$S_g = 351 \times \frac{15}{4} \approx 1,400 \text{ kVA}$$

- 300 kVA UPS with filter, subtransient reactance of 15%

For $\tau = 5\%$, the calculation gives $U'R_{cc} = 12\%$, power S_g is:

$$S_g = 351 \times \frac{15}{12} \approx 500 \text{ kVA}$$

Note: With an upstream transformer of 630 kVA on the 300 kVA UPS without filter, the 5% ratio would be obtained.

The result is that operation on generator set must be continually monitored for harmonic currents.

If voltage harmonic distortion is too great, use of a filter on the network is the most effective solution to bring it back to values that can be tolerated by sensitive loads.

1 Protection of a LV generator set and the downstream circuits

1.4 Generator Set parallel-connection

Parallel-connection of the generator set irrespective of the application type - Safety source, Replacement source or Production source - requires finer management of connection, i.e. additional monitoring functions.

Parallel operation

As generator sets generate energy in parallel on the same load, they must be synchronised properly (voltage, frequency) and load distribution must be balanced properly. This function is performed by the regulator of each Generator Set (thermal and excitation regulation). The parameters (frequency, voltage) are monitored before connection: if the values of these parameters are correct, connection can take place.

Insulation faults (see Fig. N12)

An insulation fault inside the metal casing of a generator set may seriously damage the generator of this set if the latter resembles a phase-to-neutral short-circuit. The fault must be detected and eliminated quickly, else the other generators will generate energy in the fault and trip on overload: installation continuity of supply will no longer be guaranteed. Ground Fault Protection (GFP) built into the generator circuit is used to:

- Quickly disconnect the faulty generator and preserve continuity of supply
- Act at the faulty generator control circuits to stop it and reduce the risk of damage

This GFP is of the “Residual Sensing” type and must be installed as close as possible to the protection device as per a TN-C/TN-S^[1] system at each generator set with grounding of frames by a separate PE. This kind of protection is usually called “Restricted Earth Fault”.

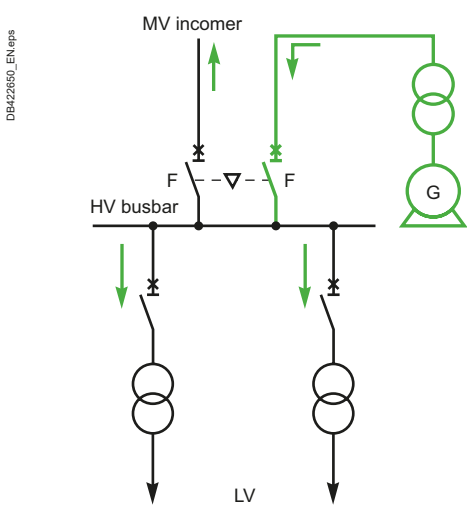


Fig. N13 Energy transfer direction – Generator Set as a generator

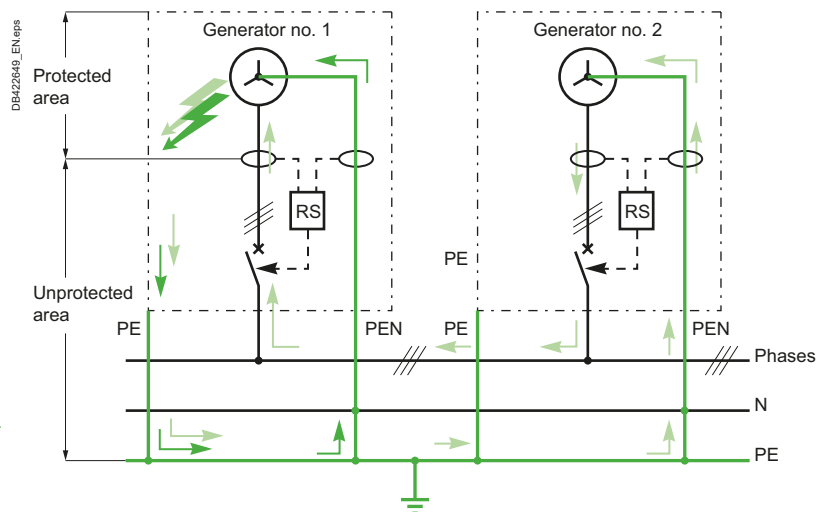


Fig. N12 Insulation fault inside a generator

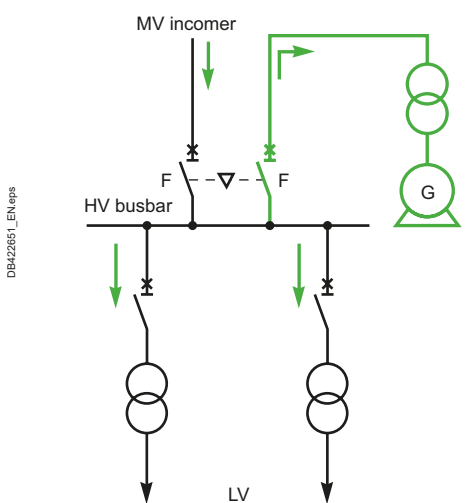


Fig. N14 Energy transfer direction – Generator Set as a load

[1] The system is in TN-C for sets seen as the “generator” and in TN-S for sets seen as “loads”

Generator Set operating as a load (see Fig. N13 and Fig. N14)

One of the parallel-connected generator sets may no longer operate as a generator but as a motor (by loss of its excitation for example). This may generate overloading of the other generator set(s) and thus place the electrical installation out of operation.

To check that the generator set really is supplying the installation with power (operation as a generator), the proper flow direction of energy on the coupling busbar must be checked using a specific “reverse power” check. Should a fault occur, i.e. the set operates as a motor, this function will eliminate the faulty set.

Grounding parallel-connected Generator Sets

Grounding of connected generator sets may lead to circulation of earth fault currents (triplen harmonics) by connection of neutrals for common grounding (grounding system of the TN or TT type). Consequently, to prevent these currents from flowing between the generator sets, we recommend the installation of a decoupling resistance in the grounding circuit.

2 Uninterruptible Power Supply units (UPS)

2.1 Availability and quality of electrical power

The disturbances presented above may affect:

- Safety of human life
- Safety of property
- The economic viability of a company or production process

Disturbances must therefore be eliminated.

A number of technical solutions contribute to this goal, with varying degrees of effectiveness. These solutions may be compared on the basis of two criteria:

- Availability of the power supplied
- Quality of the power supplied

The availability of electrical power can be thought of as the time per year that power is present at the load terminals. Availability is mainly affected by power interruptions due to utility outages or electrical faults.

A number of solutions exist to limit the risk:

- Division of the installation so as to use a number of different sources rather than just one
- Subdivision of the installation into priority and non-priority circuits, where the supply of power to priority circuits can be picked up if necessary by another available source
- Load shedding, as required, so that a reduced available power rating can be used to supply standby power
- Selection of a system earthing arrangement suited to service-continuity goals, e.g. IT system
- Selectivity of protection devices (selective tripping) to limit the consequences of a fault to a part of the installation

Note that the only way of ensuring availability of power with respect to utility outages is to provide, in addition to the above measures, an autonomous alternate source, at least for priority loads (see Fig. N15).

This source takes over from the utility in the event of a problem, but two factors must be taken into account:

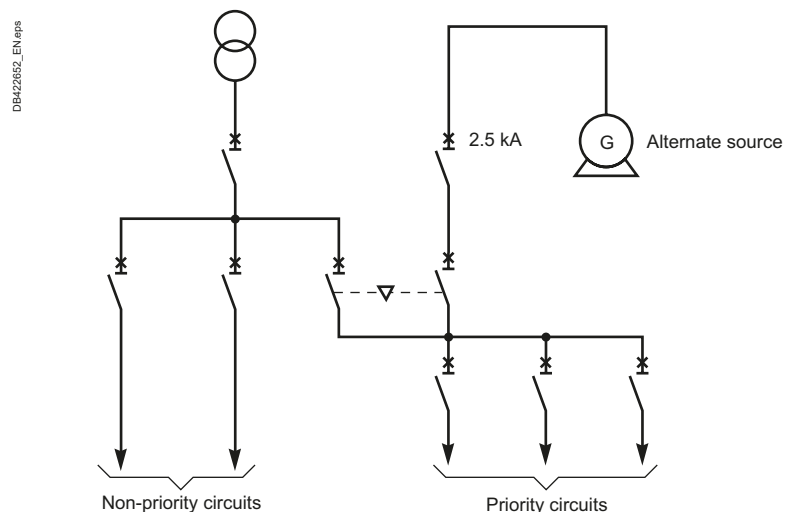


Fig. N15 Availability of electrical power

- The transfer time (time required to take over from the utility) which must be acceptable to the load
- The operating time during which it can supply the load

The quality of electrical power is determined by the elimination of the disturbances at the load terminals.

An alternate source is a means to ensure the availability of power at the load terminals, however, it does not guarantee, in many cases, the quality of the power supplied with respect to the above disturbances.

2 Uninterruptible Power Supply units (UPS)

Today, many sensitive electronic applications require an electrical power supply which is virtually free of these disturbances, to say nothing of outages, with tolerances that are stricter than those of the utility.

This is the case, for example, for computer centers, telephone exchanges and many industrial-process control and monitoring systems.

These applications require solutions that ensure both the availability and quality of electrical power.

The UPS solution

The solution for sensitive applications is to provide a power interface between the utility and the sensitive loads, providing voltage that is:

- Free of all disturbances present in utility power and in compliance with the strict tolerances required by loads
- Available in the event of a utility outage, within specified tolerances

UPSs (Uninterruptible Power Supplies) satisfy these requirements in terms of power availability and quality by:

- Supplying loads with voltage complying with strict tolerances, through use of an inverter
- Providing an autonomous alternate source, through use of a battery
- Stepping in to replace utility power with no transfer time, i.e. without any interruption in the supply of power to the load, through use of a static switch

These characteristics make UPSs the ideal power supply for all sensitive applications because they ensure power quality and availability, whatever the state of utility power.

A UPS comprises the following main components:

- Rectifier/charger, which produces DC power to charge a battery and supply an inverter
- Inverter, which produces quality electrical power, i.e.
 - Free of all utility-power disturbances, notably micro-outages
 - Within tolerances compatible with the requirements of sensitive electronic devices (e.g. for Galaxy, tolerances in amplitude $\pm 0.5\%$ and frequency $\pm 1\%$, compared to $\pm 10\%$ and $\pm 5\%$ in utility power systems, which correspond to improvement factors of 20 and 5, respectively)
- Battery, which provides sufficient backup time (8 minutes to 1 hour or more) to ensure the safety of life and property by replacing the utility as required
- Static switch, a semi-conductor based device which transfers the load from the inverter to the utility and back, without any interruption in the supply of power

2.2 Types of static UPSs

Types of static UPSs are defined by standard IEC 62040.

The standard distinguishes three operating modes:

- Passive standby (also called off-line)
- Line interactive
- Double conversion (also called on-line)

These definitions concern UPS operation with respect to the power source including the distribution system upstream of the UPS.

Standard IEC 62040 defines the following terms:

- Primary power: power normally continuously available which is usually supplied by an electrical utility company, but sometimes by the user's own generation
- Standby power: power intended to replace the primary power in the event of primary-power failure
- Bypass power: power supplied via the bypass

Practically speaking, a UPS is equipped with two AC inputs, which are called the normal AC input and bypass AC input in this guide.

- The normal AC input, noted as mains input 1, is supplied by the primary power, i.e. by a cable connected to a feeder on the upstream utility or private distribution system
- The bypass AC input, noted as mains input 2, is generally supplied by standby power, i.e. by a cable connected to an upstream feeder other than the one supplying the normal AC input, backed up by an alternate source (e.g. by an engine-generator set or another UPS, etc.)

When standby power is not available, the bypass AC input is supplied with primary power (second cable parallel to the one connected to the normal AC input).

The bypass AC input is used to supply the bypass line(s) of the UPS, if they exist. Consequently, the bypass line(s) is supplied with primary or standby power, depending on the availability of a standby-power source.

2 Uninterruptible Power Supply units (UPS)

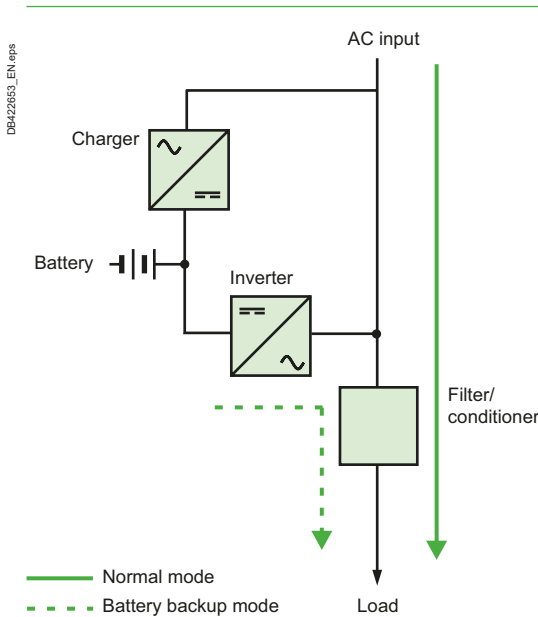


Fig. N16 UPS operating in passive standby mode

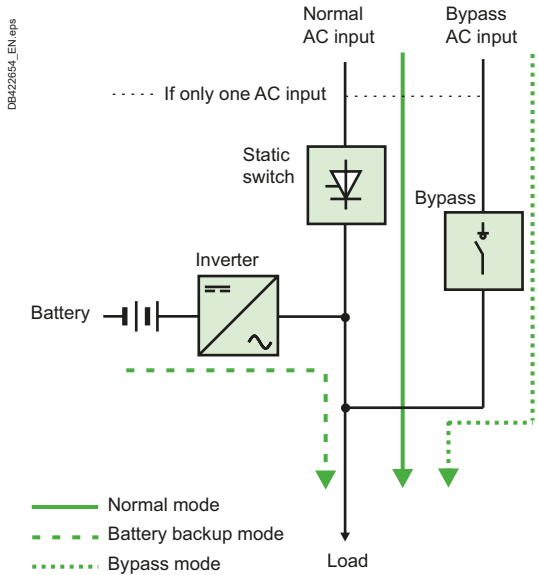


Fig. N17 UPS operating in line-interactive mode

UPS operating in passive-standby (off-line) mode

Operating principle

The inverter is connected in parallel with the AC input in a standby (see Fig. N16).

■ Normal mode

The load is supplied by utility power via a filter which eliminates certain disturbances and provides some degree of voltage regulation (the standard speaks of “additional devices...to provide power conditioning”). The inverter operates in passive standby mode.

■ Battery backup mode

When the AC input voltage is outside specified tolerances for the UPS or the utility power fails, the inverter and the battery step in to ensure a continuous supply of power to the load following a very short (<10 ms) transfer time.

The UPS continues to operate on battery power until the end of battery backup time or the utility power returns to normal, which provokes transfer of the load back to the AC input (normal mode).

Usage

This configuration is in fact a compromise between an acceptable level of protection against disturbances and cost. It can be used only with low power ratings (< 2 kVA).

It operates without a real static switch, so a certain time is required to transfer the load to the inverter. This time is acceptable for certain individual applications, but incompatible with the performance required by more sophisticated, sensitive systems (large computer centers, telephone exchanges, etc.).

What is more, the frequency is not regulated and there is no bypass.

Note: In normal mode, the power supplying the load does not flow through the inverter, which explains why this type of UPS is sometimes called “Off-line”. This term is misleading, however, because it also suggests “not supplied by utility power”, when in fact the load is supplied by the utility via the AC input during normal operation. That is why standard IEC 62040 recommends the term “passive standby”.

UPS operating in line-interactive mode

Operating principle

The inverter is connected in parallel with the AC input in a standby configuration, but also charges the battery. It thus interacts (reversible operation) with the AC input source (see Fig. N17).

■ Normal mode

The load is supplied with conditioned power via a parallel connection of the AC input and the inverter. The inverter operates to provide output-voltage conditioning and/or charge the battery. The output frequency depends on the AC-input frequency.

■ Battery backup mode

When the AC input voltage is outside specified tolerances for the UPS or the utility power fails, the inverter and the battery step in to ensure a continuous supply of power to the load following a transfer without interruption using a static switch which also disconnects the AC input to prevent power from the inverter from flowing upstream.

The UPS continues to operate on battery power until the end of battery backup time or the utility power returns to normal, which provokes transfer of the load back to the AC input (normal mode).

■ Bypass mode

This type of UPS may be equipped with a bypass. If one of the UPS functions fails, the load can be transferred to the bypass AC input (supplied with utility or standby power, depending on the installation).

Usage

This configuration is not well suited to regulation of sensitive loads in the medium to high-power range because frequency regulation is not possible.

For this reason, it is rarely used other than for low power ratings.

UPS operating in double-conversion (on-line) mode

Operating principle

The inverter is connected in series between the AC input and the application.

■ Normal mode

During normal operation, all the power supplied to the load passes through the rectifier/charger and inverter which together perform a double conversion (AC-DC-AC), hence the name.

■ Battery backup mode

When the AC input voltage is outside specified tolerances for the UPS or the utility power fails, the inverter and the battery step in to ensure a continuous supply of power to the load following a transfer without interruption using a static switch.

The UPS continues to operate on battery power until the end of battery backup time or utility power returns to normal, which provokes transfer of the load back to the AC input (normal mode).

2 Uninterruptible Power Supply units (UPS)

■ Bypass mode

This type of UPS is generally equipped with a static bypass, sometimes referred to as a static switch (see Fig. N18).

The load can be transferred without interruption to the bypass AC input (supplied with utility or standby power, depending on the installation), in the event of the following:

- UPS failure
- Load-current transients (inrush or fault currents)
- Load peaks

However, the presence of a bypass assumes that the input and output frequencies are identical and if the voltage levels are not the same, a bypass transformer is required.

For certain loads, the UPS must be synchronized with the bypass power to ensure load-supply continuity. What is more, when the UPS is in bypass mode, a disturbance on the AC input source may be transmitted directly to the load because the inverter no longer steps in.

Note: Another bypass line, often called the maintenance bypass, is available for maintenance purposes. It is closed by a manual switch.

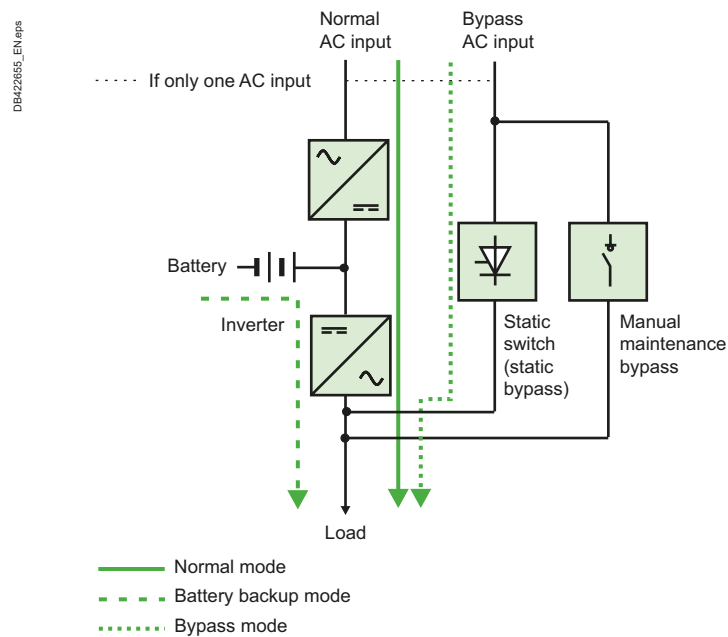


Fig. N18 UPS operating in double-conversion (on-line) mode

Usage

In this configuration, the time required to transfer the load to the inverter is negligible due to the static switch.

Also, the output voltage and frequency do not depend on the input voltage and frequency conditions. This means that the UPS, when designed for this purpose, can operate as a frequency converter.

Practically speaking, this is the main configuration used for medium and high power ratings (from 10 kVA upwards). The rest of this chapter will consider only this configuration.

Note: This type of UPS is often called "on-line", meaning that the load is continuously supplied by the inverter, regardless of the conditions on the AC input source. This term is misleading, however, because it also suggests "supplied by utility power", when in fact the load is supplied by power that has been reconstituted by the double-conversion system. That is why standard IEC 62040 recommends the term "double conversion".

2 Uninterruptible Power Supply units (UPS)

2.3 Batteries

Selection of battery type

A battery is made up of interconnected cells which may be vented or of the recombination type.

There are two main families of batteries:

- Nickel-cadmium batteries
- Lead-acid batteries
- Vented cells (lead-antimony): They are equipped with ports to
 - Release to the atmosphere the oxygen and hydrogen produced during the different chemical reactions
 - Top off the electrolyte by adding distilled or demineralized water
- Recombination cells (lead, pure lead, lead-tin batteries): The gas recombination rate is at least 95% and they therefore do not require water to be added during service life

By extension, reference will be made to vented or recombination batteries (recombination batteries are also often called “sealed” batteries).

The main types of batteries used in conjunction with UPSs are:

- Sealed lead-acid batteries, used 95% of the time because they are easy to maintain and do not require a special room
- Vented lead-acid batteries
- Vented nickel-cadmium batteries

The above three types of batteries may be proposed, depending on economic factors and the operating requirements of the installation, with all the available service-life durations.

Capacity levels and backup times may be adapted to suit the user's needs.

The proposed batteries are also perfectly suited to UPS applications in that they are the result of collaboration with leading battery manufacturers.

Selection of back up time

Selection depends on:

- The average duration of power-system failures
- Any available long-lasting standby power (engine-generator set, etc.)
- The type of application

The typical range generally proposed is:

- Standard backup times of 10, 15 or 30 minutes
- Custom backup times

The following general rules apply:

- Computer applications

Battery backup time must be sufficient to cover file-saving and system-shutdown procedures required to ensure a controlled shutdown of the computer system.

Generally speaking, the computer department determines the necessary backup time, depending on its specific requirements.

- Industrial processes

The backup time calculation should take into account the economic cost incurred by an interruption in the process and the time required to restart.

Selection table

Fig. N19 next page sums up the main characteristics of the various types of batteries.

Increasingly, recombination batteries would seem to be the market choice for the following reasons:

- No maintenance
- Easy implementation
- Installation in all types of rooms (computer rooms, technical rooms not specifically intended for batteries, etc.)

In certain cases, however, vented batteries are preferred, notably for:

- Long service life
- Long backup times
- High power ratings

Vented batteries must be installed in special rooms complying with precise regulations and require appropriate maintenance.

2 Uninterruptible Power Supply units (UPS)

	Service life	Compact	Operating temperature tolerances	Frequency of maintenance	Special room	Cost
Sealed lead-acid	5 or 10 years	+	+	Low	No	Low medium
Vented lead-acid	5 or 10 years	+	++	Medium	Yes	Low
Nickel-cadmium	5 or 10 years	++	+++	High	No	High

Fig. N19 Main characteristics of the various types of batteries

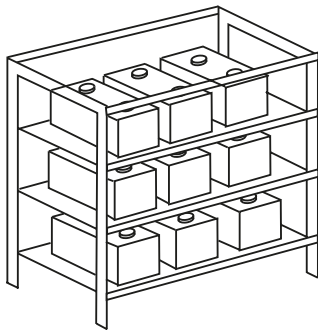


Fig. N20 Shelf mounting

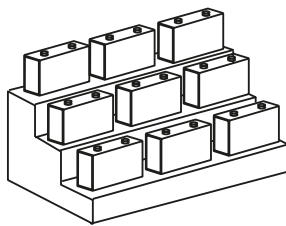


Fig. N21 Tier mounting

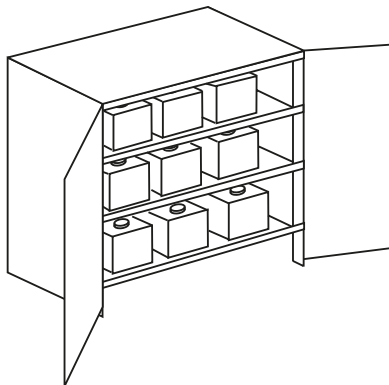


Fig. N22 Cabinet mounting

Installation methods

Depending on the UPS range, the battery capacity and backup time, the battery is:

- Sealed type and housed in the UPS cabinet
 - Sealed type and housed in one to three cabinets
 - Vented or sealed type and rack-mounted. In this case the installation method may be
 - On shelves (see Fig. N20)
 - Tier mounting (see Fig. N21)
 - In cabinets (see Fig. N22)
- This installation method is suitable for sealed batteries or maintenance-free vented batteries which do not require topping up of their electrolyte.
- This installation method is suitable for all types of batteries and for vented batteries in particular, as level checking and filling are made easy.
- This installation method is suitable for sealed batteries. It is easy to implement and offers maximum safety.

2.4 System earthing arrangements for installations comprising UPSs

Application of protection systems, stipulated by the standards, in installations comprising a UPS, requires a number of precautions for the following reasons:

- The UPS plays two roles
 - A load for the upstream system
 - A power source for downstream system
 - When the battery is not installed in a cabinet, an insulation fault on the DC system can lead to the flow of a residual DC component
- This component can disturb the operation of certain protection devices, notably RCDs used for the protection of persons.

Protection against direct contact (see Fig. N23)

All installations satisfy the applicable requirements because the equipment is housed in cabinets providing a degree of protection IP 20. This is true even for the battery when it is housed in a cabinet.

When batteries are not installed in a cabinet, i.e. generally in a special room, the measures presented at the end of this chapter should be implemented.

Note: The TN system (version TN-S or TN-C) is the most commonly recommended system for the supply of computer systems.

Type of arrangement	IT system	TT system	TN system
Operation	<ul style="list-style-type: none"> ■ Signaling of first insulation fault ■ Locating and elimination of first fault ■ Disconnection for second insulation fault 	<ul style="list-style-type: none"> ■ Disconnection for first insulation fault 	<ul style="list-style-type: none"> ■ Disconnection for first insulation fault
Techniques for protection of persons	<ul style="list-style-type: none"> ■ Interconnection and earthing of conductive parts ■ Surveillance of first fault using an insulation monitoring device (IMD) ■ Second fault results in circuit interruption (circuit breaker or fuse) 	<ul style="list-style-type: none"> ■ Earthing of conductive parts combined with use of RCDs ■ First insulation fault results in interruption by detecting leakage currents 	<ul style="list-style-type: none"> ■ Interconnection and earthing of conductive parts and neutral imperative ■ First insulation fault results in interruption by detecting overcurrents (circuit breaker or fuse)
Advantages and disadvantages	<ul style="list-style-type: none"> ■ Solution offering the best continuity of service (first fault is signalled) ■ Requires competent surveillance personnel (location of first fault) 	<ul style="list-style-type: none"> ■ Easiest solution in terms of design and installation ■ No insulation monitoring device (IMD) required ■ However, each fault results in interruption of the concerned circuit 	<ul style="list-style-type: none"> ■ Low-cost solution in terms of installation ■ Difficult design (calculation of loop impedances) ■ Qualified operating personnel required ■ Flow of high fault currents

Fig. N23 Main characteristics of system earthing arrangements

2 Uninterruptible Power Supply units (UPS)

Essential points to be checked for UPSs

Fig. N24 shows all the essential points that must be interconnected as well as the devices to be installed (transformers, RCDs, etc.) to ensure installation conformity with safety standards.

DB422659_EN_ups

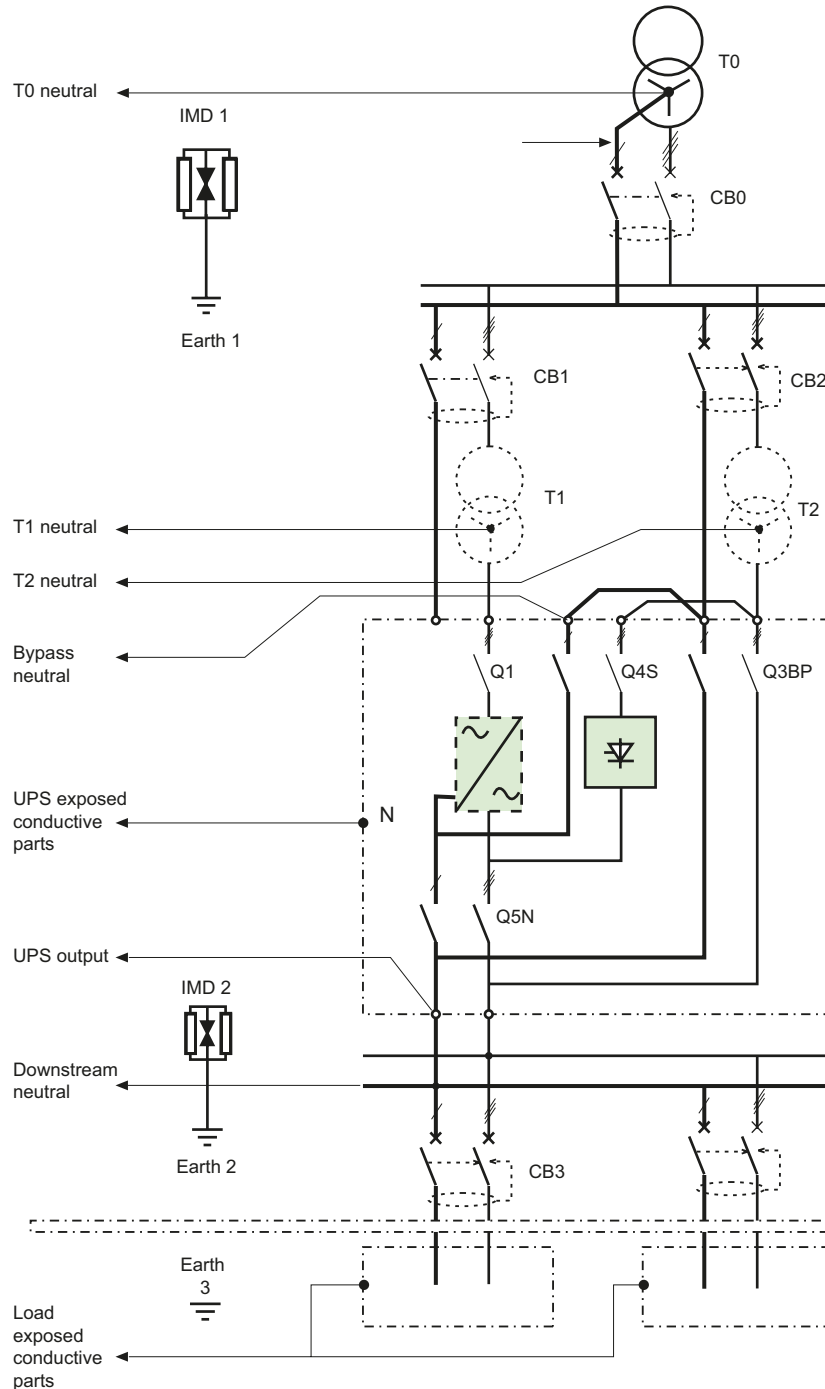


Fig. N24 The essential points that must be connected in system earthing arrangements

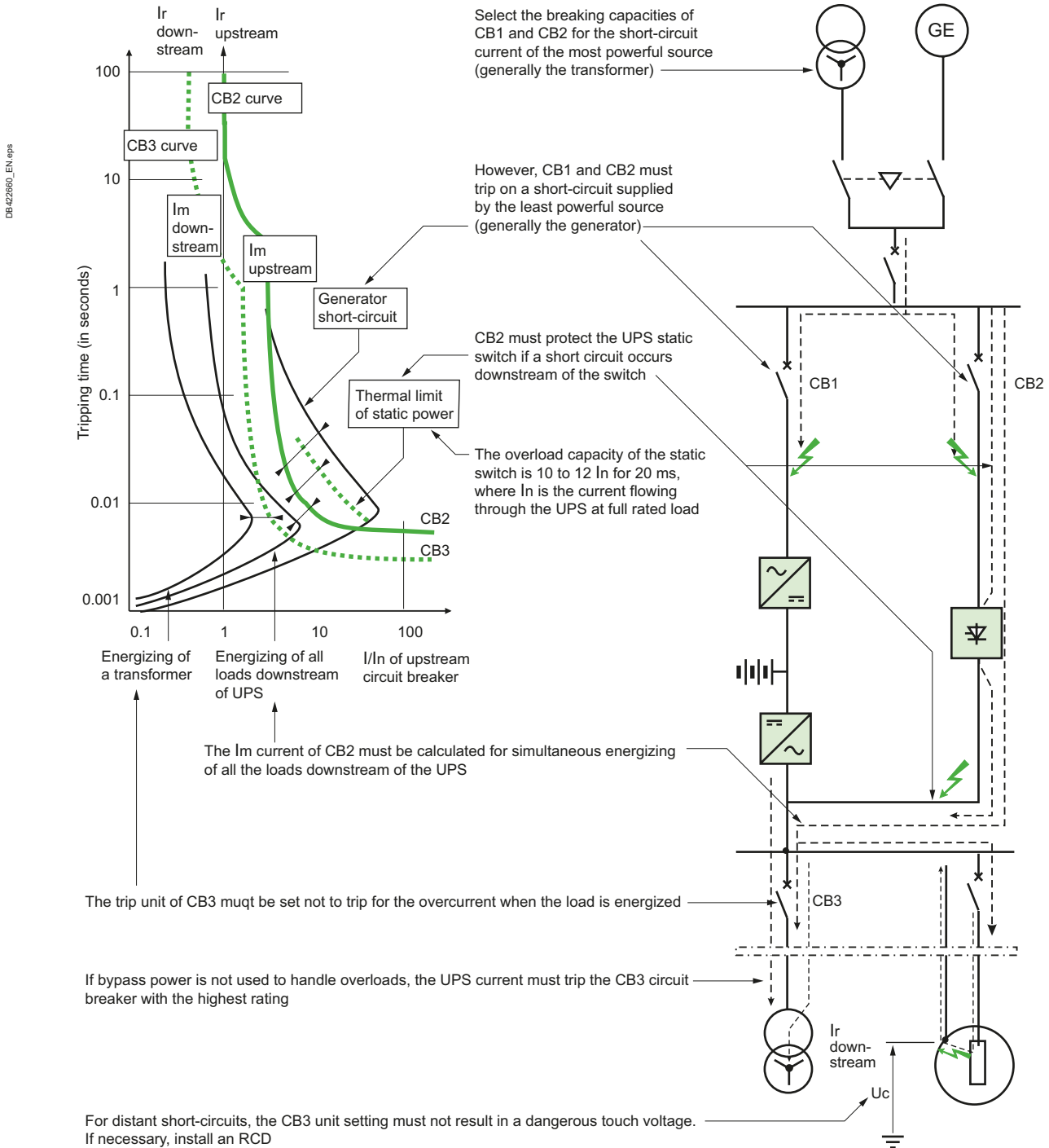
2 Uninterruptible Power Supply units (UPS)

2.5 Choice of protection schemes

The circuit breakers have a major role in an installation but their importance often appears at the time of accidental events which are not frequent. The best sizing of UPS and the best choice of configuration can be compromised by a wrong choice of only one circuit breaker.

Circuit breaker selection

Fig. N25 shows how to select the circuit breakers.



N18

Fig. N25 Circuit breakers are submitted to a variety of situations

2 Uninterruptible Power Supply units (UPS)

Rating

The selected rating (rated current) for the circuit breaker must be the one just above the rated current of the protected downstream cable.

Breaking capacity

The breaking capacity must be selected just above the short-circuit current that can occur at the point of installation.

I_r and I_m thresholds

The table below indicates how to determine the I_r (overload ; thermal or longtime) and I_m (short-circuit ; magnetic or short time) thresholds to ensure selectivity, depending on the upstream and downstream trip units.

Remark (see Fig. N26)

- Time selectivity must be implemented by qualified personnel because time delays before tripping increase the thermal stress (I²t) downstream (cables, semi-conductors, etc.). Caution is required if tripping of CB2 is delayed using the I_m threshold time delay
- Energy selectivity does not depend on the trip unit, only on the circuit breaker

Type of downstream circuit	I _r upstream / I _r downstream ratio	I _m upstream / I _m downstream ratio	I _m upstream / I _m downstream ratio
Downstream trip unit	All types	Magnetic	Electronic
Distribution	> 1.6	>2	>1.5
Asynchronous motor	>3	>2	>1.5

Fig. N26 I_r and I_m thresholds depending on the upstream and downstream trip units

Special case of generator short-circuits

Fig. N27 shows the reaction of a generator to a short-circuit.

To avoid any uncertainty concerning the type of excitation, we will trip at the first peak (3 to 5 I_n as per X''d) using the I_m protection setting without a time delay.

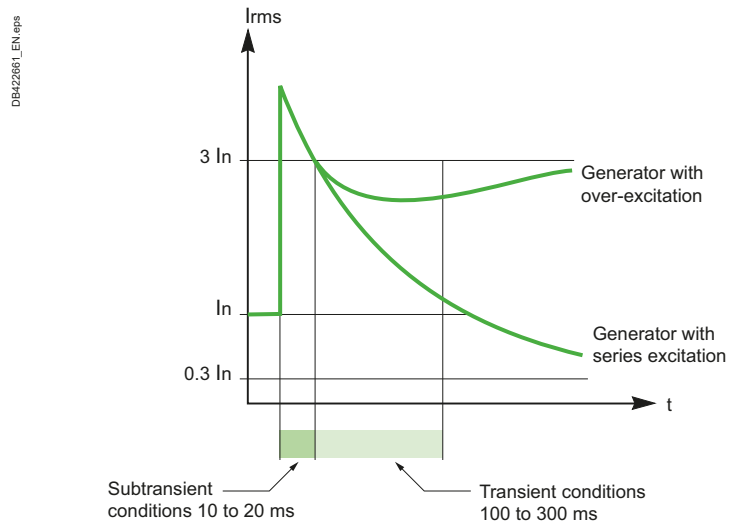


Fig. N27 Generator during short-circuit

2 Uninterruptible Power Supply units (UPS)

2.6 Installation, connection and sizing of cables

Ready-to-use UPS units

The low power UPSs, for micro computer systems for example, are compact ready-to-use equipment. The internal wiring is built in the factory and adapted to the characteristics of the devices.

Not ready-to-use UPS units

For the other UPSs, the wire connections to the power supply system, to the battery and to the load are not included.

Wiring connections depend on the current level as indicated in Fig. N28 below.

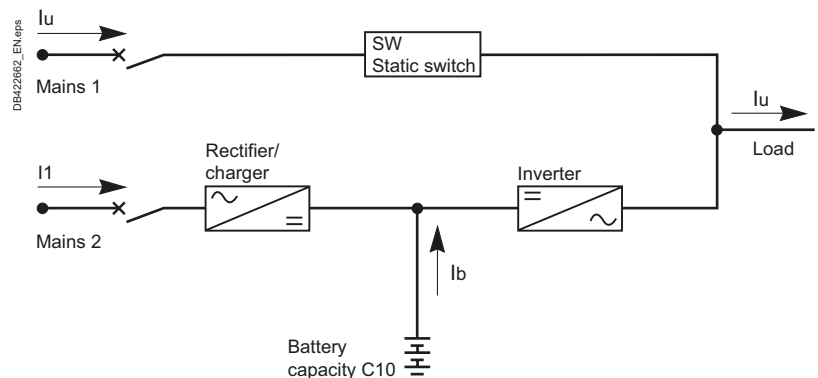


Fig. N28 Current to be taken into account for the selection of the wire connections

Calculation of currents I_1 , I_u

- The input current I_u from the power network is the load current
- The input current I_1 of the charger/rectifier depends on:
 - The capacity of the battery (C_{10}) and the charging mode (I_b)
 - The characteristics of the charger
 - The efficiency of the inverter
- The current I_b is the current in the connection of the battery

These currents are given by the manufacturers.

Cable temperature rise and voltage drops

The cross section of cables depends on:

- Permissible temperature rise
- Permissible voltage drop

For a given load, each of these parameters results in a minimum permissible cross section. The larger of the two must be used.

When routing cables, care must be taken to maintain the required distances between control circuits and power circuits, to avoid any disturbances caused by HF currents.

Temperature rise

Permissible temperature rise in cables is limited by the withstand capacity of cable insulation.

Temperature rise in cables depends on:

- The type of core (Cu or Al)
- The installation method
- The number of touching cables

Standards stipulate, for each type of cable, the maximum permissible current.

Voltage drops

The maximum permissible voltage drops are:

- 3% for AC circuits (50 or 60 Hz)
- 1% for DC circuits

2 Uninterruptible Power Supply units (UPS)

Selection tables

Fig. N29 and **Fig. N30** indicates the voltage drop in percent for a circuit made up of 100 meters of cable. To calculate the voltage drop in a circuit with a length L, multiply the value in the table by L/100.

- Sph: Cross section of conductors
- I_n: Rated current of protection devices on circuit

Three-phase circuit

If the voltage drop exceeds 3% (50-60 Hz), increase the cross section of conductors.

DC circuit

If the voltage drop exceeds 1%, increase the cross section of conductors.

In (A)	Sph (mm ²)												
	10	16	25	35	50	70	95	120	150	185	240	300	
10	0.9												
15	1.2												
20	1.6	1.1											
25	2.0	1.3	0.9										
32	2.6	1.7	1.1										
40	3.3	2.1	1.4	1.0									
50	4.1	2.6	1.7	1.3	1.0								
63	5.1	3.3	2.2	1.6	1.2	0.9							
70	5.7	3.7	2.4	1.7	1.3	1.0	0.8						
80	6.5	4.2	2.7	2.1	1.5	1.2	0.9	0.8					
100	8.2	5.3	3.4	2.6	2.0	2.0	1.1	0.9	0.7				
125		6.6	4.3	3.2	2.4	2.4	1.4	1.1	1.0	0.8			
160			5.5	4.3	3.2	3.2	1.8	1.5	1.2	1.1	0.9		
200				5.3	3.9	3.9	2.2	1.8	1.6	1.3	1.2	0.9	
250					4.9	4.9	2.8	2.3	1.9	1.7	1.4	1.2	
320							3.5	2.9	2.5	2.1	1.9	1.5	
400							4.4	3.6	3.1	2.7	2.3	1.9	
500								4.5	3.9	3.4	2.9	2.4	
600									4.9	4.2	3.6	3.0	
800										5.3	4.4	3.8	
1,000											6.5	4.7	

For a three-phase 230 V circuit, multiply the result by $\sqrt{3}$.
For a single-phase 208/230 V circuit, multiply the result by 2.

Fig. N29 Voltage drop for three-phase circuits, 50-60 Hz, 380 V / 400 V / 415 V, $\cos \phi = 0.8$, balanced system 3L+N. Values in percent for a circuit of 100m (copper conductors)

In (A)	Sph (mm ²)											
	-	-	25	35	50	70	95	120	150	185	240	300
100			5.1	3.6	2.6	1.9	1.3	1.0	0.8	0.7	0.5	0.4
125				4.5	3.2	2.3	1.6	1.3	1.0	0.8	0.6	0.5
160					4.0	2.9	2.2	1.6	1.2	1.1	0.6	0.7
200						3.6	2.7	2.2	1.6	1.3	1.0	0.8
250							3.3	2.7	2.2	1.6	1.3	1.0
320								3.4	2.7	2.1	1.6	1.3
400									3.4	2.7	2.1	1.6
500										3.4	2.6	2.1
600										4.3	3.3	2.7
800											4.2	3.4
1,000											5.3	4.2
1,250												5.3

Fig. N30 Voltage drop for DC circuits. Values in percent for a circuit of 100m (copper conductors)

Special case for neutral conductors

In three-phase systems, the third-order harmonics (and their multiples) of single-phase loads add up in the neutral conductor (sum of the currents on the three phases).

For this reason, the following rule may be applied:
neutral cross section = 1.5 x phase cross section

2 Uninterruptible Power Supply units (UPS)

Example

Consider a 70-meter 400 V three-phase circuit, with copper conductors and a rated current of 600 A.

Standard IEC 60364 indicates, depending on the installation method and the load, a minimum cross section.

We shall assume that the minimum cross section is 95 mm².

It is first necessary to check that the voltage drop does not exceed 3%.

The table for three-phase circuits on the previous page indicates, for a 600 A current flowing in a 300 mm² cable, a voltage drop of 3% for 100 meters of cable, i.e. for 70 meters:

$$3 \times \frac{70}{100} = 2.1 \%$$

Therefore less than 3%

A identical calculation can be run for a DC current of 1,000 A.

In a ten-meter cable, the voltage drop for 100 meters of 240 mm² cable is 5.3%, i.e. for ten meters:

$$5.3 \times \frac{10}{100} = 0.53 \%$$

Therefore less than 3%

2.7 The UPSs and their environment

The UPSs can communicate with electrical and computing environment. They can receive some data and provide information on their operation in order:

- To optimize the protection

For example, the UPS provides essential information on operating status to the computer system (load on inverter, load on static bypass, load on battery, low battery warning)

- To remotely control

The UPS provides measurement and operating status information to inform and allow operators to take specific actions

- To manage the installation

The operator has a building and energy management system which allow to obtain and save information from UPSs, to provide alarms and events and to take actions.

This evolution towards compatibility between computer equipment and UPSs has the effect to incorporate new built-in UPS functions.

2.8 Complementary equipment

Transformers

A two-winding transformer included on the upstream side of the static contactor of circuit 2 allows:

- A change of voltage level when the power network voltage is different to that of the load
- A change of system of earthing between the networks

Moreover, such a transformer :

- Reduces the short-circuit current level on the secondary, (i.e load) side compared with that on the power network side
- Prevents third harmonic currents which may be present on the secondary side from passing into the power-system network, providing that the primary winding is connected in delta.

Anti-harmonic filter

The UPS system includes a battery charger which is controlled by thyristors or transistors. The resulting regularly-chopped current cycles "generate" harmonic components in the power-supply network.

These undesirable components are filtered at the input of the rectifier and for most cases this reduces the harmonic current level sufficiently for all practical purposes.

2 Uninterruptible Power Supply units (UPS)

In certain specific cases however, notably in very large installations, an additional filter circuit may be necessary.

For example when :

- The power rating of the UPS system is large relative to the MV/LV transformer supplying it
- The LV busbars supply loads which are particularly sensitive to harmonics
- A diesel (or gas-turbine, etc.) driven alternator is provided as a standby power supply

In such cases, the manufacturer of the UPS system should be consulted

Communication equipment

Communication with equipment associated with computer systems may entail the need for suitable facilities within the UPS system. Such facilities may be incorporated in an original design (see **Fig. N31**), or added to existing systems on request (see **Fig. N32**).

PB116809 eps



Fig. N31 Ready-to-use UPS unit (with DIN module)

PB116810 eps



Fig. N32 UPS unit achieving disponibility and quality of computer system power supply

3 Protection of LV/LV transformers

These transformers are generally in the range of several hundreds of VA to some hundreds of kVA and are frequently used for:

- Changing the low voltage level for:
 - Auxiliary supplies to control and indication circuits
 - Lighting circuits (230 V created when the primary system is 400 V 3-phase 3-wires)
- Changing the method of earthing for certain loads having a relatively high capacitive current to earth (computer equipment) or resistive leakage current (electric ovens, industrial-heating processes, mass-cooking installations, etc.)

LV/LV transformers are generally supplied with protective systems incorporated, and the manufacturers must be consulted for details. Overcurrent protection must, in any case, be provided on the primary side. The exploitation of these transformers requires a knowledge of their particular function, together with a number of points described below.

Note: In the particular cases of LV/LV safety isolating transformers at extra-low voltage, an earthed metal screen between the primary and secondary windings is frequently required, according to circumstances, as recommended in European Standard EN 60742.

3.1 Transformer-energizing inrush current

At the moment of energizing a transformer, high values of transient current (which includes a significant DC component) occur, and must be taken into account when considering protection schemes (see Fig. N33).

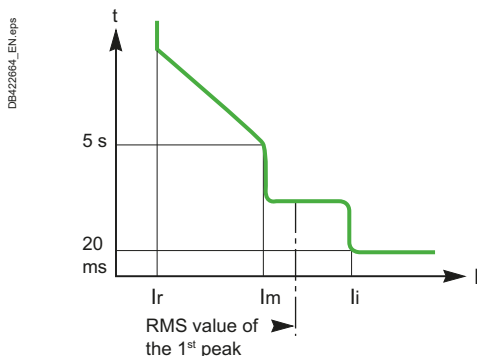


Fig. N34 Tripping characteristic of a Compact NSX with electronic trip-unit

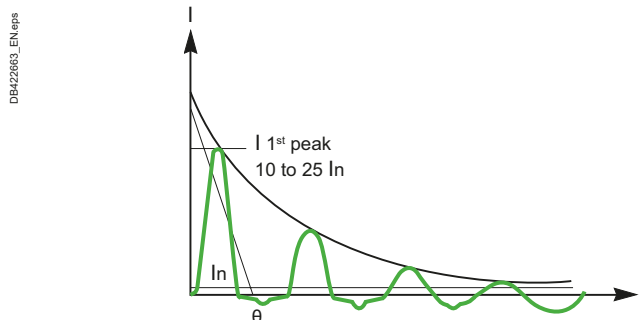


Fig. N33 Transformer-energizing inrush current

The magnitude of the current peak depends on:

- The value of voltage at the instant of energization
- The magnitude and polarity of the residual flux existing in the core of the transformer
- Characteristics of the load connected to the transformer

The first current peak can reach a value equal to 10 to 15 times the full-load r.m.s. current, but for small transformers (< 50 kVA) may reach values of 20 to 25 times the nominal full-load current. This transient current decreases rapidly, with a time constant θ of the order of several ms to several tens of ms.

3.2 Protection for the supply circuit of a LV/LV transformer

The protective device on the supply circuit for a LV/LV transformer must avoid the possibility of incorrect operation due to the magnetizing inrush current surge, noted above. It is necessary to use therefore:

- Selective (i.e. slightly time-delayed) circuit breakers of the type Compact NSX with electronic trip-unit (see Fig. N34) or
- Circuit breakers having a very high magnetic-trip setting, of the types Compact NSX or Acti 9 curve D (see Fig. N35)

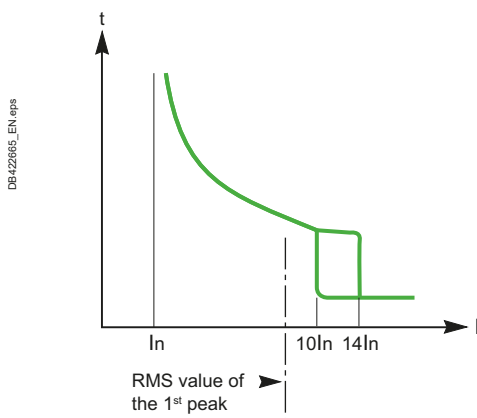


Fig. N35 Tripping characteristic of a Acti 9 curve D

3 Protection of LV/LV transformers

DB422666_EN.eps

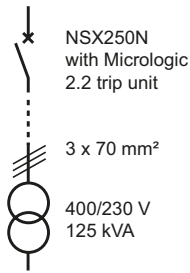


Fig. N36 Example

Example

A 400 V 3-phase circuit is supplying a 125 kVA 400/230 V transformer ($I_n = 180 \text{ A}$) for which the first inrush current peak can reach $12 I_n$, i.e. $12 \times 180 = 2,160 \text{ A}$.

This current peak corresponds to a rms value of 1,530 A.

A compact NSX250N circuit breaker with I_r setting of 200 A and I_m setting at $8 \times I_r$ would therefore be a suitable protective device.

A particular case: Overload protection installed at the secondary side of the transformer (see Fig. N36)

An advantage of overload protection located on the secondary side is that the short-circuit protection on the primary side can be set at a high value, or alternatively a circuit breaker type MA (magnetic only) can be used. The primary side short-circuit protection setting must, however, be sufficiently sensitive to ensure its operation in the event of a short-circuit occurring on the secondary side of the transformer.

Note: The primary protection is sometimes provided by fuses, type aM. This practice has two disadvantages:

- The fuses must be largely oversized (at least 4 times the nominal full-load rated current of the transformer)
- In order to provide isolating facilities on the primary side, either a load-break switch or a contactor must be associated with the fuses.

3.3 Typical electrical characteristics of LV/LV 50 Hz transformers

3-phase																							
kVA rating	5	6.3	8	10	12.5	16	20	25	31.5	40	50	63	80	100	125	160	200	250	315	400	500	630	800
No-load losses (W)	100	110	130	150	160	170	270	310	350	350	410	460	520	570	680	680	790	950	1160	1240	1485	1855	2160
Full-load losses (W)	250	320	390	500	600	840	800	1180	1240	1530	1650	2150	2540	3700	3700	5900	5900	6500	7400	9300	9400	11400	13400
Short-circuit voltage (%)	4.5	4.5	4.5	5.5	5.5	5.5	5.5	5.5	5	5	4.5	5	5	5.5	4.5	5.5	5	5	4.5	6	6	5.5	5.5

1-phase														
kVA rating	8	10	12.5	16	20	25	31.5	40	50	63	80	100	125	160
No-load losses (W)	105	115	120	140	150	175	200	215	265	305	450	450	525	635
Full-load losses (W)	400	530	635	730	865	1065	1200	1400	1900	2000	2450	3950	3950	4335
Short-circuit voltage (%)	5	5	5	4.5	4.5	4.5	4	4	5	5	4.5	5.5	5	5

3.4 Protection of LV/LV transformers, using Schneider Electric circuit breakers

For up-to-date tables to choose the appropriate circuit breaker for protection of LV/LV transformers, refer to the latest "[Complementary Technical Information](#)" guide.

4 Lighting circuits

A source of comfort and productivity, lighting represents 15% of the quantity of electricity consumed in industry and 40% in buildings. The quality of lighting (light stability and continuity of service) depends on the quality of the electrical energy thus consumed. The supply of electrical power to lighting networks has therefore assumed great importance.

To help with their design and simplify the selection of appropriate protection devices, an analysis of the different lamp technologies is presented. The distinctive features of lighting circuits and their impact on control and protection devices are discussed. Recommendations relative to the difficulties of lighting circuit implementation are given.

4.1 The different lamp technologies

Artificial luminous radiation can be produced from electrical energy according to two principles: incandescence and luminescence.

Incandescence is the production of light via temperature elevation. The most common example is a filament heated to white state by the circulation of an electrical current. The energy supplied is transformed into heat by the Joule effect and into luminous flux.

Luminescence is the phenomenon of emission by a material of visible or almost visible luminous radiation. The material can be a gas or a solid.

- Electroluminescence of gases : a gas (or vapours) subjected to an electrical discharge emits luminous radiation (electroluminescence of gases)
- Electroluminescence in solid : electronic semi-conductor component having the ability to emit visible radiation when traversed by an electrical current.

About electroluminescence of gases since this gas does not conduct at normal temperature and pressure, the discharge is produced by generating charged particles which permit ionization of the gas. The nature, pressure and temperature of the gas determine the light spectrum.

Photoluminescence is the luminescence of a material exposed to visible or almost visible radiation (ultraviolet, infrared).

When the substance absorbs ultraviolet radiation and emits visible radiation which stops a short time after energization, this is fluorescence.

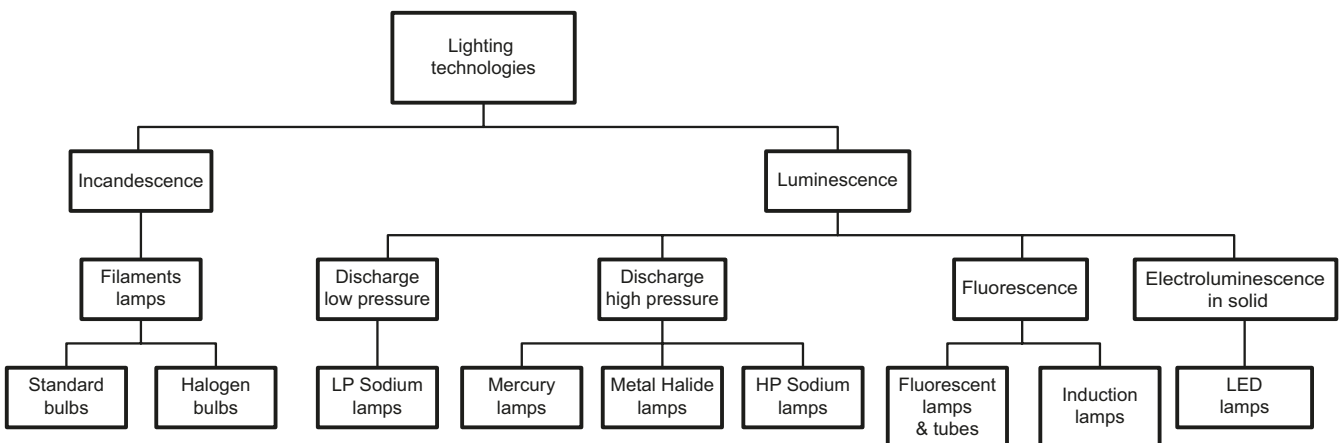


Fig. N37 Lighting technologies

DB422667_EN.eps

N26

4 Lighting circuits



Fig. N38 LED lamps

Light Emitting Diodes (LED) (see Fig. N38)

The principle of light emitting diodes is the emission of light by a semi-conductor as an electrical current passes through it.

Some years ago, LED technology was reserved for applications requiring small power light such as signalling, traffic lights, exit signs or emergency lighting.

Now thanks to the development and availability of power LED (several watts per component) lighting manufacturers offer comprehensive solutions having capability to retrofit every applications in any domains. (residential, commercial and industrial buildings, infrastructures)

In fact, LED is the first technology for lighting having the capacity to be implemented in any applications with the right level of efficiency and opening the use of control functions not accessible for other technologies.

LEDs are low-voltage and low-current devices, thus suitable for battery-supply.

A converter is required for a line power supply, called driver.

The main advantages of LEDs are their low energy consumption, robustness, long life, and capacity to be control without limits. (dimming, switching, very low voltage, no delay time for full lighting flux)

In addition, LED is easier to recycle than the fluocompact technology.

Incandescent lamps

Incandescent lamps are historically the oldest and the most often found in common use.

They are based on the principle of a filament rendered incandescent in a vacuum or neutral atmosphere which prevents combustion.

A distinction is made between:

■ Standard bulbs

These contain a tungsten filament and are filled with an inert gas (nitrogen and argon or krypton).

■ Halogen bulbs

These also contain a tungsten filament, but are filled with a halogen compound and an inert gas (krypton or xenon). This halogen compound is responsible for the phenomenon of filament regeneration, which increases the service life of the lamps and avoids them blackening. It also enables a higher filament temperature and therefore greater luminosity in smaller-size bulbs.

The main disadvantage of incandescent lamps is their significant heat dissipation, resulting in poor luminous efficiency.

Fluorescent lamps

This family covers fluorescent tubes and compact fluorescent lamps.

In fluorescent tubes, an electrical discharge causes electrons to collide with ions of mercury vapor, resulting in ultraviolet radiation due to energization of the mercury atoms. The fluorescent material, which covers the inside of the tubes, then transforms this radiation into visible light.

Fluorescent tubes dissipate less heat and have a longer service life than incandescent lamps, but they do need an ignition device called a "starter" and a device to limit the current in the arc after ignition. This device called "ballast" is usually a choke placed in series with the arc.

Compact fluorescent lamps are based on the same principle as a fluorescent tube. The starter and ballast functions are provided by an electronic circuit (integrated in the lamp) which enables the use of smaller tubes folded back on themselves.

Compact fluorescent lamps (see Fig. N39) were developed to replace incandescent lamps: They offer significant energy savings (15 W against 75 W for the same level of brightness) and an increased service life.

Lamps known as "induction" type or "without electrodes" operate on the principle of ionization of the gas present in the tube by a very high frequency electromagnetic field (up to 1 GHz). Their service life can be as long as 100,000 hrs.

Discharge lamps (see Fig. N40)

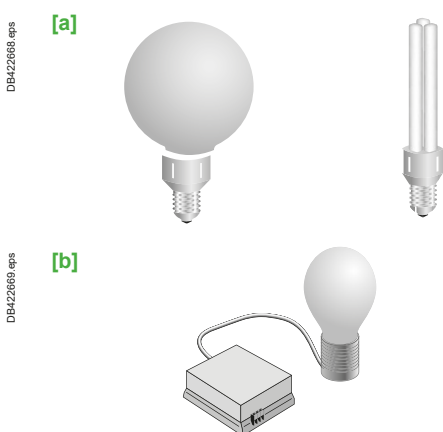
The light is produced by an electrical discharge created between two electrodes within a gas in a quartz bulb. All these lamps therefore require a ballast to limit the current in the arc. A number of technologies have been developed for different applications.

Low-pressure sodium vapor lamps have the best light output, however the color rendering is very poor since they only have a monochromatic orange radiation.

High-pressure sodium vapor lamps produce a white light with an orange tinge.

In high-pressure mercury vapor lamps, the discharge is produced in a quartz or ceramic bulb at high pressure. These lamps are called "fluorescent mercury discharge lamps". They produce a characteristically bluish white light.

Metal halide lamps are the latest technology. They produce a color with a broad color spectrum. The use of a ceramic tube offers better luminous efficiency and better color stability.



[a] standard
[b] induction

Fig. N39 Compact fluorescent lamps



Fig. N40 Discharge lamps

4 Lighting circuits

Technology	Application	Advantages	Disadvantages
LED	- any lighting application in residential, commercial or industrial building, and infrastructures	- Low energy consumption, - Low temperature in front face, - No emission in the ultraviolet and few infrared, - Robustness against vibrations, - Life time, - Insensitive to the number of switching operations - immediate relighting	- Cost (steadily declining), - Blue spectrum for white LED, - Management of temperature
Standard incandescent	- Domestic use - Localized decorative lighting	- Direct connection without intermediate switchgear - Reasonable purchase price - Compact size - Instantaneous lighting - Good color rendering	- Low luminous efficiency and high electricity consumption - Significant heat dissipation - Short service life
Halogen incandescent	- Spot lighting - Intense lighting	- Direct connection - Instantaneous efficiency - Excellent color rendering	- Average luminous efficiency
Fluorescent tube	- Shops, offices, workshops - Outdoors	- High luminous efficiency - Average color rendering	- Low light intensity of single unit - Sensitive to extreme temperatures
Compact fluorescent lamp	- Domestic use - Offices - Replacement of incandescent lamps	- Good luminous efficiency - Good color rendering	- High initial investment compared to incandescent lamps
HP mercury vapor	- Workshops, halls, hangars - Factory floors	- Good luminous efficiency - Acceptable color rendering - Compact size - Long service life	- Lighting and relighting time of a few minutes
High-pressure sodium	- Outdoors - Large halls	- Very good luminous efficiency	- Lighting and relighting time of a few minutes
Low-pressure sodium	- Outdoors - Emergency lighting	- Good visibility in foggy weather - Economical to use	- Long lighting time (5 min.) - Mediocre color rendering
Metal halide	- Large areas - Halls with high ceilings	- Good luminous efficiency - Good color rendering - Long service life	- Lighting and relighting time of a few minutes

Technology	Power (watt)	Efficiency (lumen/watt)	Service life (hours)
LED lamps	1 – 400	>100 (continuous increase)	20,000 – 50,000
Standard incandescent	3 – 1,000	10 – 15	1,000 – 2,000
Halogen incandescent	5 – 500	15 – 25	2,000 – 4,000
Fluorescent tube	4 – 56	50 – 100	7,500 – 24,000
Compact fluorescent lamp	5 – 40	50 – 80	10,000 – 20,000
HP mercury vapor	40 – 1,000	25 – 55	16,000 – 24,000
High-pressure sodium	35 – 1,000	40 – 140	16,000 – 24,000
Low-pressure sodium	35 – 180	100 – 185	14,000 – 18,000
Metal halide	30 – 2,000	50 – 115	6,000 – 20,000

Fig. N41 Usage and technical characteristics of lighting devices

The different power supply modes (see Fig. N42)

Technology	Power (watt)	Service life (hours)
LED lamps & fixtures	Driver	Driver with dimming control (1-10V or DALI mainly)
Standard incandescent	Direct power supply	Dimmer switch
Halogen incandescent		
ELV halogen incandescent	Ferro-magnetic transformer	Electronic converter
Fluorescent tube	Magnetic ballast and starter	Electronic ballast
Compact fluorescent lamp		Electronic dimmer + ballast
Mercury vapor	Built-in electronic ballast	Electronic ballast
High-pressure sodium		
Low-pressure sodium		
Metal halide		

Fig. N42 Different power supply modes

4 Lighting circuits

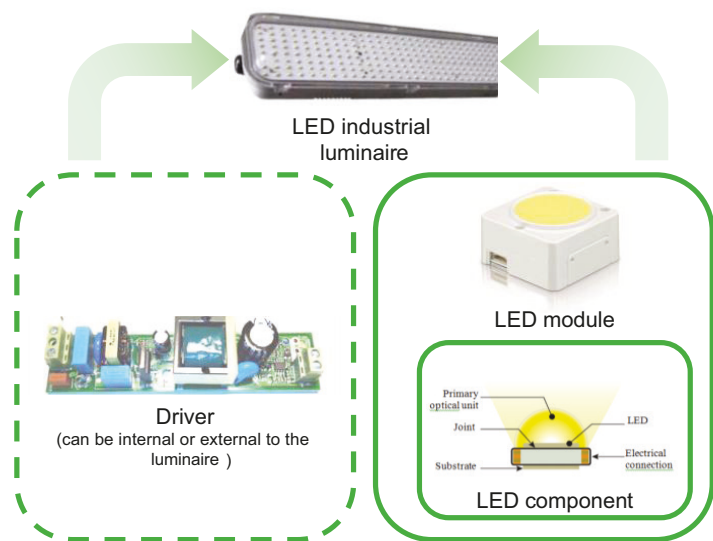
4.2 LED lighting - characteristics

The LED lighting technology presents the particularity of being the first technology to allow the development of appropriate and effective solutions for all applications of functional lighting, unlike earlier technologies.

To better understand why the use of LED lighting can result in these remarkable efficiency gains, basic terminology needs to first be explained. Listed below are definitions of the key terms in use :

- **LED (Light Emitting Diode)** - A diode type semiconductor which emits light when a current passes through it. LED semiconductor materials convert electrical energy into visible electromagnetic radiation (i.e., into light).
- **LED component** - The substrate and primary optical unit of the light assembly. The purpose of the LED component is to protect the semiconductor and to conduct the heat generated from LED to dissipation systems.
- **LED module** - The assembly of one or more LED components with optical, mechanical and thermal elements.
- **LED luminaire** - A complete system consisting of a LED module, a housing, an optical reflector, wiring, connectors, joints, heat dissipation system (heat sink or fan), and for most cases the driver
- **Driver** - An electronic device which can convert the electric power of a low-voltage AC electrical network into electric power appropriate for the LED luminaire (direct voltage and current). The driver may be external or internal to the luminaire. A driver can power one or more luminaires. Light dimming function can be embedded in this device (1-10 V control, DALI control,...)

DB422611_EN.eps



N29

Fig. N43 A LED is just one small element within a larger construct that is sold commercially as a lamp or an assembled luminaire

4 Lighting circuits

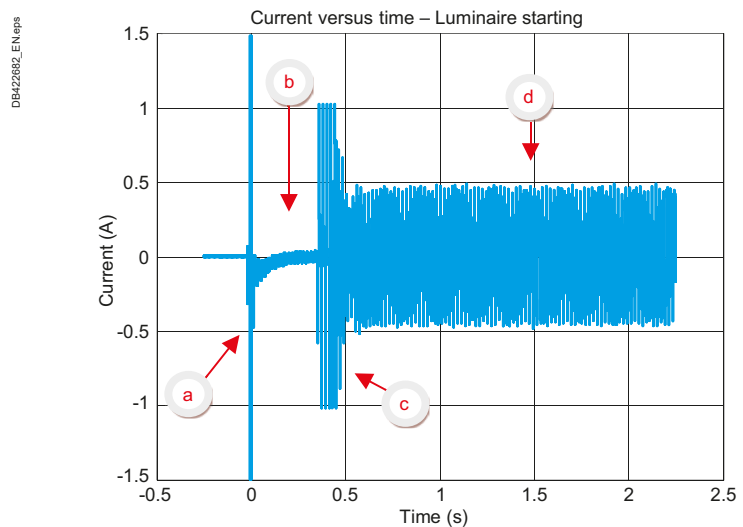
4.2.1 Inrush and steady-state currents

When a LED luminaire is first energized, a variable current is required by the luminaire during the first second time interval, and then the current stabilizes as soon as rated operating conditions are reached. Three transient fundamental events occur during the start up phase: the power supply of the luminaire, the start of the driver, and the powering of the LED module (light is on). Then the luminaire transitions to the steady state operating condition.

In the initial moments after a luminaire is energized, a significant transient current appears (can be up to 250 times the rated current depending of the characteristics of products) due to the capacitors used to perform the power factor correction (the power factor of LED luminaires is generally greater than 90%, since the luminaire driver includes a power factor correction stage). The duration of this transient current is less than 1 millisecond (ms). When the luminaire is powered on, the current will be at its highest level when the voltage angle is 90° (in that case, the voltage is at its peak value of 325 V for a 230 Volt AC network). When switching on at zero angle voltage, the inrush current is far smaller.

Once the inrush current has passed, a time range of between 100 ms and 1.5 seconds elapses. During this time, the driver is initialized (power supply for electronic control circuits, are energized, for example). The current consumed during this phase is less than the rated current.

Once the driver is initialized, the LED module is energized and light appears. An overload of about twice the rated current occurs during the initial period of power supply of the module containing the LEDs. Fig. N44 illustrates the various stages involved in energizing the luminaire. Note that state 4 in Fig. N44 represents the steady state operating condition.



- [a] State 1: Initial Power supply
- [b] State 2: Driver starting
- [c] State 3: Powering the LED module,
- [d] State 4: Steady state operating conditions

Fig. N44 Illustration of four states of a LED being energized

In the steady-state condition, the current consumed by LED luminaires is not perfectly sinusoidal. The total harmonic distortion of current (THDI) ranges between 10% and 20%. Given that the rated currents of LED luminaires are low, the impact of these currents on network voltage is slight. Measurements in various industrial plants powered by the public low-voltage power supply system (on which the short-circuit impedance is low) show that the total voltage harmonic distortion (THDV) is generally less than 3%. According to the IEC 61000-2-4 [1] standard relating to the compatibility levels of voltage tolerances, if the THDV is less than 5% (class 1 electromagnetic environment), the network is considered sound and compliant.

[1] IEC 61000-2-4 standard: Electromagnetic compatibility (EMC) – Part 2: Environment – Section 4: Compatibility levels in industrial plants for low-frequency conducted disturbances

4 Lighting circuits

4.2.2 Common mode currents

Definition: when currents flow without close-by opposing currents, the unopposed portion of current is referred to as common mode current. Common mode currents can result in radiation which can then result in interference or distortion.

How LED technology deals with this challenge? In the following example, measurements were performed by first energizing 20 luminaires that were isolated from earth. Given the configuration, the leakage current could only be looped back via the protective earth (PE) conductor of the power cable. The current flowing in this conductor at the energizing stage is presented below (see Fig. N45)

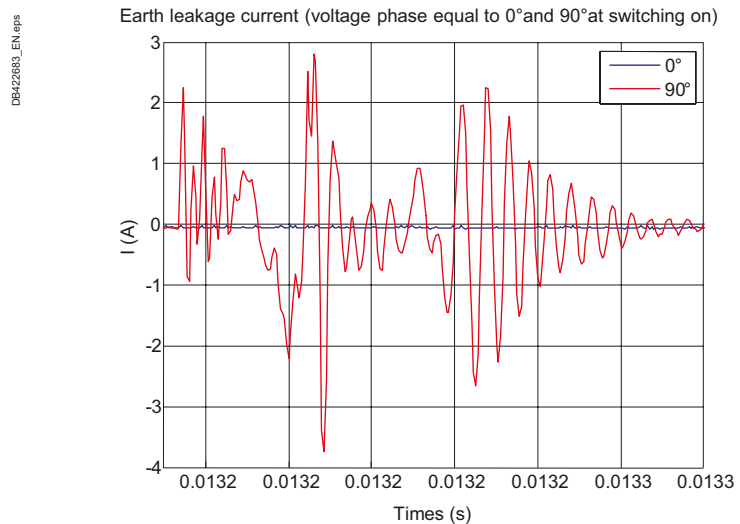


Fig. N45 Depiction of earth leakage current test results

For switching on at zero voltage, the leakage current is practically zero.

The frequency of the transient current is high (about 100 kHz).

At the steady state stage, for the 20 luminaires isolated from earth, the leakage current value measured at 50 Hz was about 2 mA.

4.3 LED lighting - constraints and recommendations

In order to understand the impact that LED technologies will have on existing electrical networks, it is important to analyze the behavior of all key elements in the network. Below is a list of potential risks to consider and also some recommendations for mitigating those risks.

4.3.1 The risk related to circuit breaker selection

The choice of circuit breaker characteristics depends on the nature of the load powered. The rating depends on the cross section of the cables to be protected and the curves are chosen according to the loads' inrush current.

When switching on LED luminaires, very significant inrush currents occur up to 250 times the nominal current according to the type of driver for a very short time (< 1 msec). Normative curves according to the "standard" (curves as defined in NF EN 60898^[1] and NF EN 60947-2^[2]) used for circuit breaker certifications (which characterize fault currents of a duration exceeding 10 ms) give the circuit breakers' tripping threshold for currents maintained for 10 ms or more. For transient currents of duration less than 10 ms, no normalized curve exists. The peak value of the total current at switching on depends on the energizing time, the number of luminaires forming the lighting circuit, and the short-circuit power and architecture of the network.

Recommendations:

In order to address this risk an appropriate choice of the circuit breaker (rating, curve) must be done during the design phase of installation, according to the recommendations given by the manufacturer.

Another option, very useful in the case of replacing conventional lighting by LED lighting on existing large installation, is to implement a remote control including zero crossing function in place of standard device. That will limit the total inrush current in the order of 4 to 5.

[1] NF EN 60898 standard: Electrical accessories – Circuit breakers for overcurrent protection for household and similar installations

[2] NF EN 60947-2 standard: Low-voltage switchgear and controlgear - Part 2: Circuit breakers

4 Lighting circuits

4.3.2 The risk relating to Earth leakage protection device

The leakage current is at maximum for switching on at the voltage peak. The frequency of this transient current is high (about 100 kHz). For switching on at zero voltage, the leakage current is practically zero.

Recommendations:

The permanent earth leakage current at 50 Hz is generally less than 1 mA for a luminaire. Given that lighting circuits are protected by earth leakage protection devices of 300 mA rating in commercial application, a large number of luminaires can be installed downstream of a protective device. For a frequency of 100 kHz, the current is not detected by the earth leakage protection devices.

4.3.3 The risk for remote control device

The standardized categories of use (according to NF EN 60947-4-1^[1] and IEC 61095^[2]) stipulate the current values that the contactor must establish or cut off. These depend on the nature of the load controlled and the conditions under which circuit (closing and breaking) is performed. Only lighting loads employing conventional technologies are covered by this standard, and no test is required to certify contactors for controlling luminaires that employ LED technology. For switchgear and control gear, the main constraints of the LED lighting technology are the high transient currents which can generate premature wear of contact pad materials.

Recommendations with standard relays

Contactor and impulse relay deratings given by manufacturers must be taken in account in the design phase in order to obtain the right coordination level with LED lighting. That performance will determine the maintain of the electrical endurance and lifetime given by manufacturers.

Solution with smart relays - smart contactor using zero crossing principle

A technique exists to limit the current peak on energization of circuits with capacitive behavior (magnetic ballasts with parallel compensation, electronic ballasts, driver). It consists of ensuring that powering of lighting occurs at the moment when the line voltage passes through zero (called "zero crossing function").

The use of remote control device including zero crossing function will reduce dramatically the inrush current generate at switch on (in the order of 4 to 5 times). Up to now, only solid state switches with semi-conductors offer this possibility but with the constraints to heating generated few compatible with conventional electrical distribution system.

The operating principle of the static relay consists of the following: when the control voltage is applied to the relay input, an internal static component performs the switching function at zero crossing of the voltage wave. The accuracy at switching (connection to the network) is excellent. The inrush current is then reduced (see Fig. N46). As a result, it is possible to use circuit breakers without derating. The number of luminaires that can be powered by a single circuit is limited only by the thermal withstand of the smart relay.

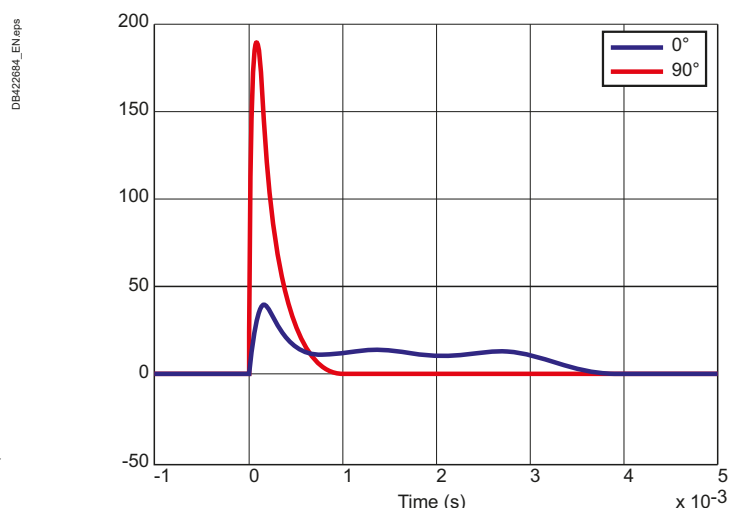


Fig. N46 Current at switching "on" according to voltage angle (zero crossing and 90°)

[1] NF EN 60947-4-1: Low-voltage switchgear and controlgear - Part 4-1: Contactors and motor-starters - Electromechanical contactors and motor-starters

[2] IEC 61095: Electromechanical contactors for household and similar purposes

4 Lighting circuits

More recently, hybrid technology devices have been developed that combine a solid state switch (activation on voltage passage through zero) and an electromechanical contactor short-circuiting the solid state switch (reduction of losses in the semiconductors) (see Fig. N68).

For three-phase circuits (power supply of luminaires between a phase conductor and the neutral conductor), switchgear and controlgear of the three-pole type is preferable to a control device of the four-pole type. Not switched the neutral pole will help to prevent a harmful voltage surge at power frequency from being applied across the terminals of the luminaire if the neutral conductor fails to close.

4.3.4 Overvoltages

The risk

As illustrated in earlier sections, switching on a lighting circuit causes a transient state which is manifested by a significant overcurrent. This overcurrent is accompanied by a strong voltage fluctuation applied to the load terminals connected to the same circuit.

These voltage fluctuations can be detrimental to correct operation of sensitive loads (micro-computers, temperature controllers, etc.)

The Solution

It is advisable to separate the power supply for these sensitive loads from the lighting circuit power supply.

The installation of protective devices such as “surge arrester” type is recommended for exposed installations such as public lighting, lighting for car park, or industrial facilities.

For LED lamps, the device which limits the number of luminaires is the MCB and not the contactor like for other lamp technologies

4.4 LED lamps - choice of circuit breaker

The new lighting technologies with electronic interfaces (ballasts, drivers) cause a high transient inrush current at power up that can trip the circuit breaker. These phenomena are particularly increased with LED lighting.

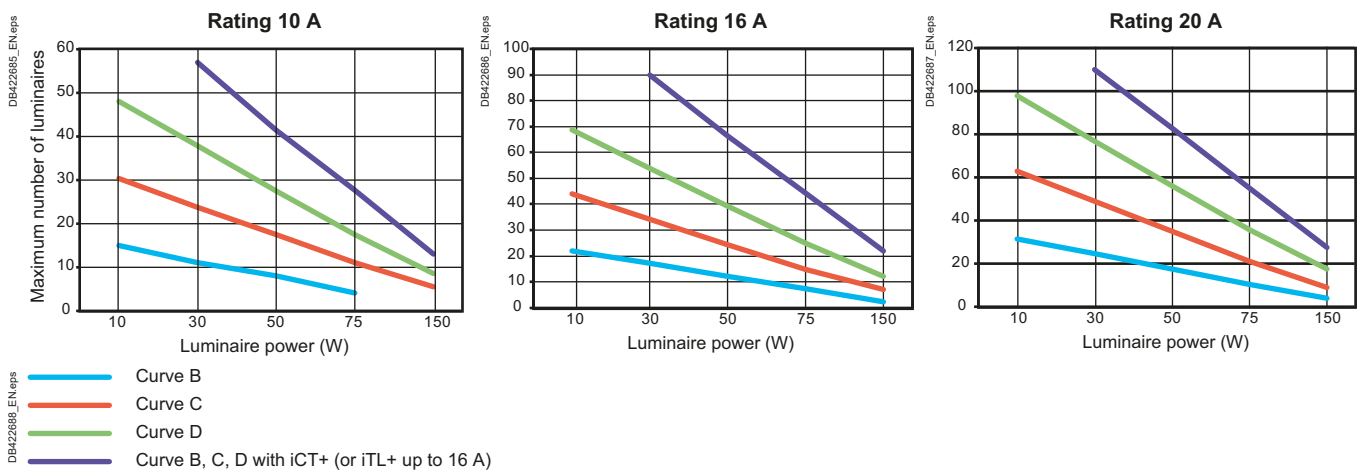


Fig. N47 Coordination between circuit breaker and luminaires LED

Unit power of the luminaire (W)	Circuit breaker rating and curve											
	10A				16A				20A			
	B	C	D	B, C, D with iCT+ or iTL+	B	C	D	B, C, D with iCT+ or iTL+	B	C	D	B, C, D with iCT+
10	15	30	48	-	22	44	69	-	32	63	98	-
30	11	24	38	57	17	34	54	90	25	49	77	110
50	8	17	27	41	12	25	39	66	18	35	56	83
75	4	11	17	28	7	15	25	44	11	21	36	55
150	-	5	9	13	2	7	12	22	4	9	18	28
250	-	3	5	8	-	4	7	13	-	5	10	16
400	-	1	4	5	-	2	6	8	-	3	9	10

Fig. N48 Maximum number of lamps according to the circuit breaker rating and curve, for LED lamps

4 Lighting circuits

According to the control device used, the transient current surge may:

- require the circuit breaker to be derated according to the number of luminaires / circuit breaker rating coordination curves, when using standard control devices: CT, TL (electromechanical control device),
- be reduced by the use of the following technologies:
 - softStart: using a command integrated in the driver or a dimmer switch,
 - controlled contactor (iTL+, iCT+) (closes when the voltage passes through «0», derating is related to the Cos φ of the lighting circuit).

These technologies allow circuit breakers without derating related to the technology of the lamps to be used.

Example:

$$\text{Circuit rated power} = 230 \text{ V AC} \times \text{Circuit breaker rating} \times \text{Cos } \phi.$$

4.5 LED lamps - choice of contactors

Fig. N49 and Fig. N50 show the maximum number of LED lamps for each contactor / relay.

- These values are given for a 230 V circuit with 2 active conductors (single-phase phase/neutral or two-phase phase/phase). For 110 V circuits, divide the values in the table by 2.
- To obtain the equivalent values for the whole of a 230 V three-phase circuit, multiply the number of lamps and the total acceptable power:
 - by $\sqrt{3}$ (1.73) for circuits with 230 V between phases without neutral,
 - by 3 for circuits with 230 V between phase and neutral or 400 V between phases.
- for Reflex iC60:
 - B-curve ratings, the number of lamps should be reduced by 50 %.
 - D-curve ratings, the number of lamps should be increased by 50 %.


Products	ICT contactors								ICT+ contactors	
	Maximum number of light fittings for a single-phase circuit and maximum power output per circuit									
Type of lamp	16 A		25 A		40 A		63 A		20 A	
LED lamps										
With driver	10 W	48	500 to 1400 W	69	700 to 1950 W	98	1000 to 3000 W	200	2000 to 6200 W	4660 W x Cos φ
	30 W	38		54		77		157		
	50 W	27		39		56		114		
	75 W	17		25		36		73		
	150 W	9		12		18		37		
	200 W	7		9		15		31		

Fig. N49 Maximum number of LED lamps for ICT and ICT+ contactors


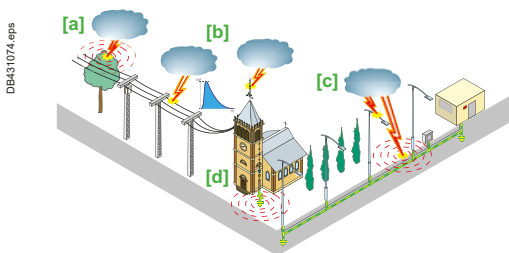
Products	iTL impulse relays				iTL+ impulse relays		Reflex iC60 (C curve)										
	Maximum number of light fittings for a single-phase circuit and maximum power output per circuit																
Type of lamp	16 A		32 A		16 A		10 A		16 A		25 A		40 A		63 A		
LED lamps																	
With driver	10 W	69	700 to 1950 W	98	1000 to 3000 W	3680 W x Cos φ		30	300 to 850 W	44	450 to 1250 W	71	700 to 2000 W	108	1050 to 3050 W	146	1450 to 4150 W
	30 W	54		77				24		34		55		83		113	
	50 W	39		56				17		25		40		61		83	
	75 W	25		36				11		15		24		37		50	
	150 W	12		18				5		7		11		17		23	
	200 W	9		15				-		6		10		15		20	

Fig. N50 Maximum number of LED lamps for iTL and iTL+ impulse relays, and for Reflex iC60 (C-Curve)



- [a] Radiation
- [b] Conducted
- [c] Direct
- [d] Rise in earth potential

The use of surge protective devices can reduce risks of failure.

Fig. N51 Direct and indirect lightning strikes

4.6 Outdoor LED lighting

4.6.1 Sensitivity to surge

LED-technology luminaires containing electronic components are sensitive to surge, which will attack the power supply drivers and LED components and therefore drastically reduce the luminaires' theoretical lifetime.

The effects of lightning strokes can be approached in two ways: when the component examined is the one which receives the lightning, this is a case of a direct lightning stroke, and when the component examined merely sustains effects, this is an indirect lightning stroke.

4 Lighting circuits

4.6.2 Surge generated by lightning

The atmospheric phenomenon of lightning is due to the sudden discharge of the electrical energy accumulated in storm clouds.

- Direct lightning stroke: when the lightning falls on a structure, the lightning current generates a pulse surge.
- Indirect lightning stroke: this is the remote manifestation of a direct lightning stroke. Its effects are presented here from three aspects: conducted surge, rise in earth potential and radiation.

Note: Refer also to "[Overvoltage protection](#)", chapter J.

4.6.3 Temporary Overvoltage

The main characteristic of these surges is their frequency which assumes that of the network: generally 50 Hz or 60 Hz.

Types of surges are called TOV (for Temporary Over Voltage). These TOV could be generated by a fault on power system, neutral breaking for example: although distribution networks are normally three-phase, many switchgear items are single-phase. Depending on the needs of each low voltage consumer, voltage unbalances may occur. The most problematic case is breaking of the neutral which may generate a rise in potential that is harmful for devices programmed to operate at single-phase voltage and which then find themselves operating at a voltage close to phase-to-phase voltage.

4.6.4 Outdoor LED installation protection

Protection against transient surges

Surge protection devices must be used in order to protect public outdoor LED lighting installation.

An entire range of surge arresters is thus available: modular arresters for mounting on a symmetrical rail, arresters that can be installed in a main low voltage board or in luminaire enclosures. They all enable flow off of various currents with a varying voltage protection level.

In addition, surge arresters for information circuit must be used. They must be adapted for two low-current lines without common potential used in public lighting. The input current must not exceed 300 mA.

Protection against TOV by voltage threshold tripping device

The protective device will trip when the voltage across its terminals exceeds its nominal value.

Miniature circuit breaker, surge protection device and voltage threshold tripping device are available in an complete integrated product (see Fig. N55).

Conclusion

The complete installation protection (with zero-crossing contactor, surge protection devices and voltage threshold tripping device) is represented on Fig. N56.

We can see on Fig. N56 that surge protection devices are installed in the streetlight main switchboard and in the junction box located in the bottom of the lighting columns. These protections are easily accessible for service. In case of failure, replacement is quick and easy.

The connection of the metallic lighting columns to the earthing system allows the adjustment of different parts of the lighting system to the same potential, thus reducing significantly the overvoltages that occur on the luminaires.

PE119915.eps



Fig. N52 Type 2 surge protection device

PE107131_35.eps



Fig. N53 Surge arrester for information circuit

DB431075.eps

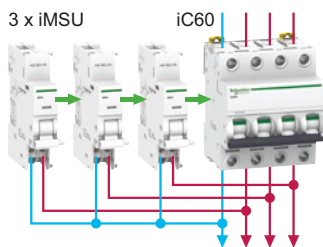


Fig. N54 Voltage threshold tripping device

PE1106302.eps



Fig. N55 Miniature circuit breaker, surge protection device and voltage threshold tripping device

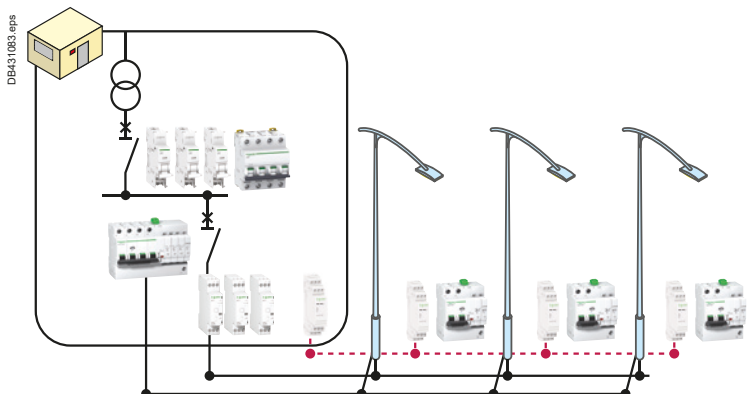


Fig. N56 Outdoor LED lighting protection

4 Lighting circuits

4.7 Other lamp technologies - characteristics

For LED lamps, see "[LED lighting - characteristics](#)".

4.7.1 Incandescent lamps

Incandescent lamps with direct power supply

Due to the very high temperature of the filament during operation (up to 2,500 °C), its resistance varies greatly depending on whether the lamp is on or off. As the cold resistance is low, a current peak occurs on ignition that can reach 10 to 15 times the nominal current for a few milliseconds or even several milliseconds.

This constraint affects both ordinary lamps and halogen lamps: it imposes a reduction in the maximum number of lamps that can be powered by devices such as remote-control switches, modular contactors and relays for busbar trunking.

Extra Low Voltage (ELV) halogen lamps

■ Some low-power halogen lamps are supplied with ELV 12 or 24 V, via a transformer or an electronic converter. With a transformer, the magnetization phenomenon combines with the filament resistance variation phenomenon at switch-on. The inrush current can reach 50 to 75 times the nominal current for a few milliseconds. The use of dimmer switches placed upstream significantly reduces this constraint.

■ Electronic converters, with the same power rating, are more expensive than solutions with a transformer. This commercial handicap is compensated by a greater ease of installation since their low heat dissipation means they can be fixed on a flammable support. Moreover, they usually have built-in thermal protection.

New ELV halogen lamps are now available with a transformer integrated in their base. They can be supplied directly from the LV line supply and can replace normal lamps without any special adaptation.

Dimming for incandescent lamps

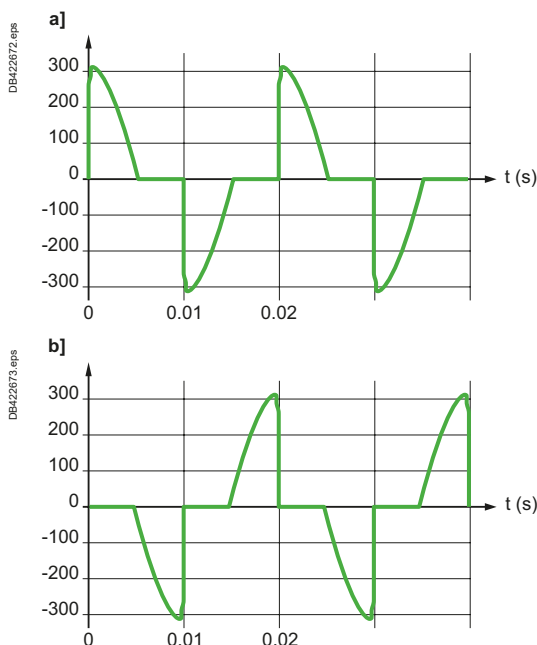
This can be obtained by varying the voltage applied to the lamp

This voltage variation is usually performed by a device such as a Triac dimmer switch, by varying its firing angle in the line voltage period. The wave form of the voltage applied to the lamp is illustrated in **Fig. N57a**. This technique known as "cut-on control" is suitable for supplying power to resistive or inductive circuits. Another technique suitable for supplying power to capacitive circuits has been developed with MOS or IGBT electronic components. This technique varies the voltage by blocking the current before the end of the half-period (see **Fig. N57b**) and is known as "cut-off control".

Switching on the lamp gradually can also reduce, or even eliminate, the current peak on ignition.

As the lamp current is distorted by the electronic switching, harmonic currents are produced. The 3rd harmonic order is predominant, and the percentage of 3rd harmonic current related to the maximum fundamental current (at maximum power) is represented on **Fig. N58**.

Note that in practice, the power applied to the lamp by a dimmer switch can only vary in the range between 15 and 85% of the maximum power of the lamp



[a] "cut-on control"
[b] "cut-off control"

Fig. N57 Shape of the voltage supplied by a light dimmer at 50% of maximum voltage with the following techniques

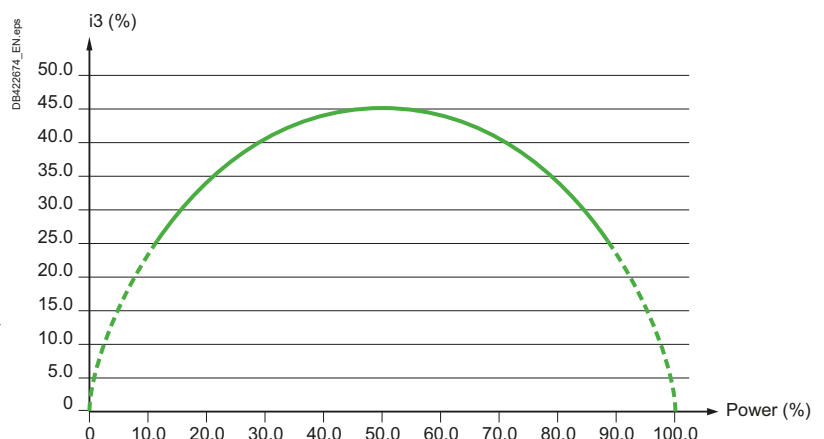


Fig. N58 Percentage of 3rd harmonic current as a function of the power applied to an incandescent lamp using an electronic dimmer switch

4 Lighting circuits

According to IEC standard 61000-3-2 setting harmonic emission limits for electric or electronic systems with current ≤ 16 A, the following arrangements apply:

- Independent dimmers for incandescent lamps with a rated power less than or equal to 1 kW have no limits applied
- Otherwise, or for incandescent lighting equipment with built-in dimmer or dimmer built in an enclosure, the maximum permissible 3rd harmonic current is equal to 2.30 A

4.7.2 Fluorescent and discharge lamps with magnetic ballast

Fluorescent tubes and discharge lamps require the intensity of the arc to be limited, and this function is fulfilled by a choke (or magnetic ballast) placed in series with the bulb itself (see Fig. N59).

This arrangement is most commonly used in domestic applications with a limited number of tubes. No particular constraint applies to the switches.

Dimmer switches are not compatible with magnetic ballasts: the cancellation of the voltage for a fraction of the period interrupts the discharge and totally extinguishes the lamp.

The starter has a dual function: preheating the tube electrodes, and then generating an overvoltage to ignite the tube. This overvoltage is generated by the opening of a contact (controlled by a thermal switch) which interrupts the current circulating in the magnetic ballast.

During operation of the starter (approx. 1 s), the current drawn by the luminaire is approximately twice the nominal current.

Since the current drawn by the tube and ballast assembly is essentially inductive, the power factor is very low (on average between 0.4 and 0.5). In installations consisting of a large number of tubes, it is necessary to provide compensation to improve the power factor.

For large lighting installations, centralized compensation with capacitor banks is a possible solution, but more often this compensation is included at the level of each luminaire in a variety of different layouts (see Fig. N60).

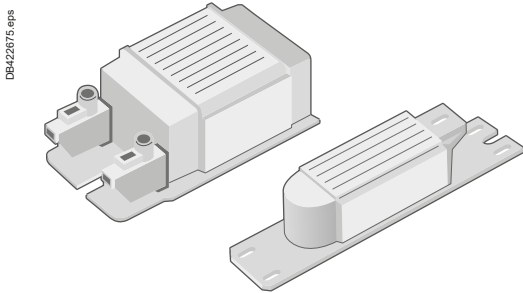
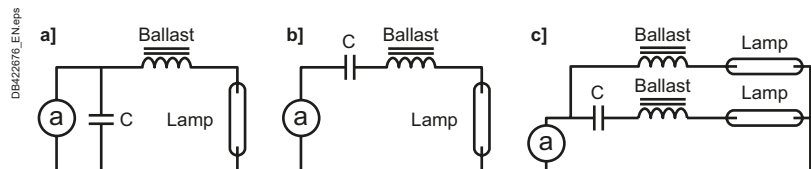


Fig. N59 Magnetic ballasts



Compensation layout	Application	Comments
Without compensation	Domestic	Single connection
Parallel ^[a]	Offices, workshops, superstores	Risk of overcurrents for control devices
Series ^[b]		Choose capacitors with high operating voltage (450 to 480 V)
Duo ^[c]		Avoids flicker

[a] parallel;

[b] series;

[c] dual series also called "duo" and their fields of application

Fig. N60 The various compensation layouts

The compensation capacitors are therefore sized so that the global power factor is greater than 0.85. In the most common case of parallel compensation, its capacity is on average 1 μ F for 10 W of active power, for any type of lamp. However, this compensation is incompatible with dimmer switches.

Constraints affecting compensation

The layout for parallel compensation creates constraints on ignition of the lamp. Since the capacitor is initially discharged, switch-on produces an overcurrent. An overvoltage also appears, due to the oscillations in the circuit made up of the capacitor and the power supply inductance.

The following example can be used to determine the orders of magnitude.

4 Lighting circuits

Assuming an assembly of 50 fluorescent tubes of 36 W each:

- Total active power: 1,800 W
- Apparent power: 2 kVA
- Total rms current: 9 A
- Peak current: 13 A

With:

- A total capacity: $C = 175 \mu\text{F}$
- A line inductance (corresponding to a short-circuit current of 5 kA): $L = 150 \mu\text{H}$

The maximum peak current at switch-on equals:

$$I_c = V_{\max} \sqrt{\frac{C}{L}} = 230\sqrt{2} \sqrt{\frac{175 \times 10^{-6}}{150 \times 10^{-6}}} = 350 \text{ A}$$

The theoretical peak current at switch-on can therefore reach **27 times** the peak current during normal operation.

The shape of the voltage and current at ignition is given in **Fig. N61** for switch closing at the line supply voltage peak.

There is therefore a risk of contact welding in electromechanical control devices (remote-control switch, contactor, circuit breaker) or destruction of solid state switches with semi-conductors.

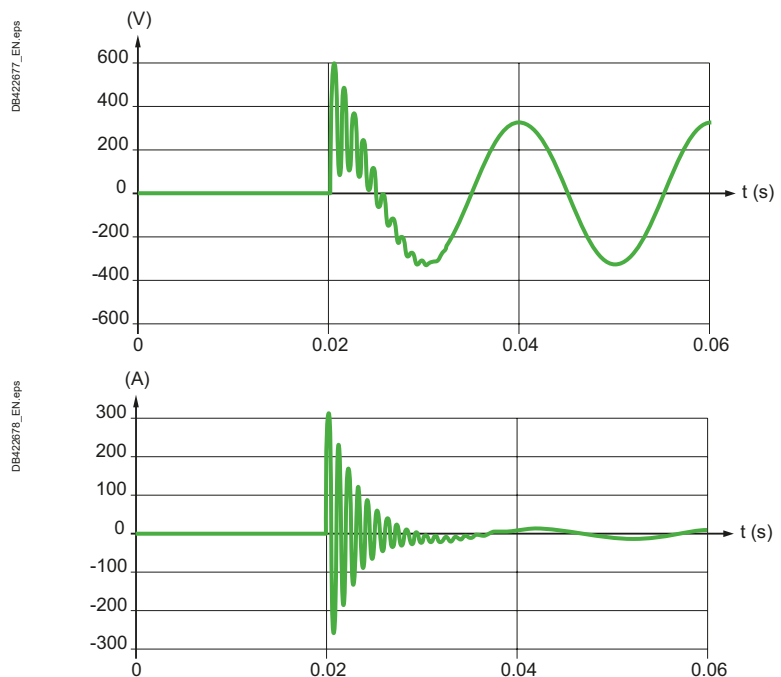


Fig. N61 Power supply voltage at switch-on and inrush current

In reality, the constraints are usually less severe, due to the impedance of the cables.

Ignition of fluorescent tubes in groups implies one specific constraint. When a group of tubes is already switched on, the compensation capacitors in these tubes which are already energized participate in the inrush current at the moment of ignition of a second group of tubes: they “amplify” the current peak in the control switch at the moment of ignition of the second group.

The table in **Fig. N62**, resulting from measurements, specifies the magnitude of the first current peak, for different values of prospective short-circuit current I_{sc} . It is seen that the current peak can be multiplied by 2 or 3, depending on the number of tubes already in use at the moment of connection of the last group of tubes.

4 Lighting circuits

Number of tubes already in use	Number of tubes connected	Inrush current peak (A)		
		Isc = 1500 A	Isc = 3000 A	Isc = 6000 A
0	14	233	250	320
14	14	558	556	575
28	14	608	607	624
42	14	618	616	632

Fig. N62 Magnitude of the current peak in the control switch of the moment of ignition of a second group of tubes

Nonetheless, sequential ignition of each group of tubes is recommended so as to reduce the current peak in the main switch.

The most recent magnetic ballasts are known as “low-loss”. The magnetic circuit has been optimized, but the operating principle remains the same. This new generation of ballasts is coming into widespread use, under the influence of new regulations (European Directive, Energy Policy Act - USA).

In these conditions, the use of electronic ballasts is likely to increase, to the detriment of magnetic ballasts.

4.7.3 Fluorescent and discharge lamps with electronic ballast

Electronic ballasts are used as a replacement for magnetic ballasts to supply power to fluorescent tubes (including compact fluorescent lamps) and discharge lamps. They also provide the “starter” function and do not need any compensation capacity.

The principle of the electronic ballast (see **Fig. N63**) consists of supplying the lamp arc via an electronic device that generates a rectangular form AC voltage with a frequency between 20 and 60 kHz.

Supplying the arc with a high-frequency voltage can totally eliminate the flicker phenomenon and strobe effects. The electronic ballast is totally silent.

During the preheating period of a discharge lamp, this ballast supplies the lamp with increasing voltage, imposing an almost constant current. In steady state, it regulates the voltage applied to the lamp independently of any fluctuations in the line voltage.

Since the arc is supplied in optimum voltage conditions, this results in energy savings of 5 to 10% and increased lamp service life. Moreover, the efficiency of the electronic ballast can exceed 93%, whereas the average efficiency of a magnetic device is only 85%.

The power factor is high (> 0.9).

The electronic ballast is also used to provide the light dimming function. Varying the frequency in fact varies the current magnitude in the arc and hence the luminous intensity.

Inrush current

The main constraint that electronic ballasts bring to line supplies is the high inrush current on switch-on linked to the initial load of the smoothing capacitors (see **Fig. N64**).

Technology	Max. inrush current	Duration
Rectifier with PFC	30 to 100 I _n	≤ 1 ms
Rectifier with choke	10 to 30	≤ 5 ms
Magnetic ballast	≤ 13 I _n	5 to 10 ms

Fig. N64 Orders of magnitude of the inrush current maximum values, depending on the technologies used

In reality, due to the wiring impedances, the inrush currents for an assembly of lamps is much lower than these values, in the order of 5 to 10 I_n for less than 5 ms. Unlike magnetic ballasts, this inrush current is not accompanied by an overvoltage.

DB42079 eps

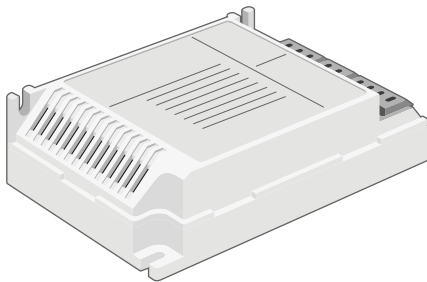


Fig. N63 Electronic ballast

4 Lighting circuits

Harmonic currents

For ballasts associated with high-power discharge lamps, the current drawn from the line supply has a low total harmonic distortion (< 20% in general and < 10% for the most sophisticated devices). Conversely, devices associated with low-power lamps, in particular compact fluorescent lamps, draw a very distorted current (see Fig. N65). The total harmonic distortion can be as high as 150%. In these conditions, the rms current drawn from the line supply equals 1.8 times the current corresponding to the lamp active power, which corresponds to a power factor of 0.55.

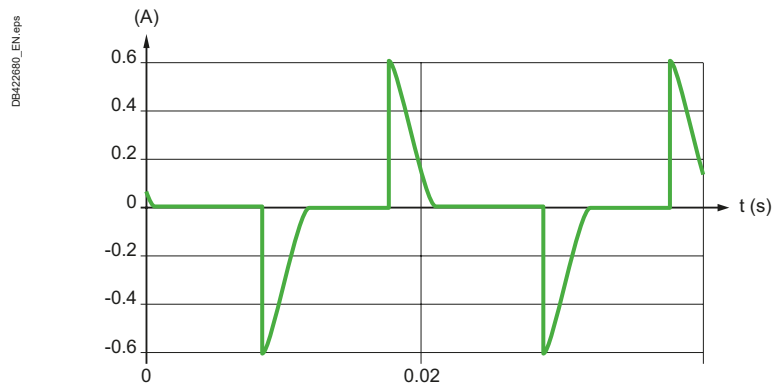


Fig. N65 Shape of the current drawn by a compact fluorescent lamp

In order to balance the load between the different phases, lighting circuits are usually connected between phases and neutral in a balanced way. In these conditions, the high level of third harmonic and harmonics that are multiple of 3 can cause an overload of the neutral conductor. The least favorable situation leads to a neutral current which may reach $\sqrt{3}$ times the current in each phase.

Harmonic emission limits for electric or electronic systems are set by IEC standard 61000-3-2. For simplification, the limits for lighting equipment are given here only for harmonic orders 3 and 5 which are the most relevant (see Fig. N66).

Harmonic order	Active input power > 25W	Active input power ≤ 25W one of the 2 sets of limits apply:	
	% of fundamental current	% of fundamental current	Harmonic current relative to active power
3	30	86	3.4 mA/W
5	10	61	1.9 mA/W

Fig. N66 Maximum permissible harmonic current

Leakage currents

Electronic ballasts usually have capacitors placed between the power supply conductors and the earth. These interference-suppressing capacitors are responsible for the circulation of a permanent leakage current in the order of 0.5 to 1 mA per ballast. This therefore results in a limit being placed on the number of ballasts that can be supplied by a Residual Current Differential Safety Device (RCD).

At switch-on, the initial load of these capacitors can also cause the circulation of a current peak whose magnitude can reach several amps for 10 μs. This current peak may cause unwanted tripping of unsuitable devices.

High-frequency emissions

Electronic ballasts are responsible for high-frequency conducted and radiated emissions.

The very steep rising edges applied to the ballast output conductors cause current pulses circulating in the stray capacities to earth. As a result, stray currents circulate in the earth conductor and the power supply conductors. Due to the high frequency of these currents, there is also electromagnetic radiation. To limit these HF emissions, the lamp should be placed in the immediate proximity of the ballast, thus reducing the length of the most strongly radiating conductors.

4 Lighting circuits

4.8 Other lamp technologies - constraints and recommendations

For LED lamps, see "[LED lighting - constraints and recommendations](#)".

4.8.1 The current actually drawn by luminaires

The risk

This characteristic is the first one that should be defined when creating an installation, otherwise it is highly probable that overload protection devices will trip and users may often find themselves in the dark.

It is evident that their determination should take into account the consumption of all components, especially for fluorescent lighting installations, since the power consumed by the ballasts has to be added to that of the tubes and bulbs.

The recommendation

For incandescent lighting, it should be remembered that the line voltage can be more than 10% of its nominal value, which would then cause an increase in the current drawn.

For fluorescent lighting, unless otherwise specified, the power of the magnetic ballasts can be assessed at 25% of that of the bulbs. For electronic ballasts, this power is lower, in the order of 5 to 10%.

The thresholds for the overcurrent protection devices should therefore be calculated as a function of the total power and the power factor, calculated for each circuit.

4.8.2 Overcurrents at switch-on

The risk

The devices used for control and protection of lighting circuits are those such as relays, triac, remote-control switches, contactors or circuit breakers.

The main constraint applied to these devices is the current peak on energization. This current peak depends on the technology of the lamps used, but also on the installation characteristics (supply transformer power, length of cables, number of lamps) and the moment of energization in the line voltage period. A high current peak, however fleeting, can cause the contacts on an electromechanical control device to weld together or the destruction of a solid state device with semi-conductors.

Two solutions

Because of the inrush current, the majority of ordinary relays are incompatible with lighting device power supply. The following recommendations are therefore usually made:

- Limit the number of lamps to be connected to a single device so that their total power is less than the maximum permissible power for the device
- Check with the manufacturers what operating limits they suggest for the devices. This precaution is particularly important when replacing incandescent lamps with compact fluorescent lamps

By way of example, the table in **Fig. N67** indicates the maximum number of compensated fluorescent tubes that can be controlled by different devices with 16 A rating. Note that the number of controlled tubes is well below the number corresponding to the maximum power for the devices.

Tube unit power requirement (W)	Number of tubes corresponding to the power 16 A x 230 V	Maximum number of tubes that can be controlled by		
		Contactors GC16 A CT16 A	Remote control switches TL16 A	Circuit breakers C60-16 A
18	204	15	50	112
36	102	15	25	56
58	63	10	16	34

Fig. N67 The number of controlled tubes is well below the number corresponding to the maximum power for the devices

4 Lighting circuits

But a technique exists to limit the current peak on energization of circuits with capacitive behavior (magnetic ballasts with parallel compensation and electronic ballasts). It consists of ensuring that activation occurs at the moment when the line voltage passes through zero. Only solid state switches with semi-conductors and specific control offer this possibility but the important heat due to permanent current requires the use of heater not compatible with conventional electrical distribution system for building (cumbersome has to be limited).

More recently, hybrid technology devices have been developed that combine a solid state switch (activation on voltage passage through zero) and an electromechanical contactor short-circuiting the solid state switch (cancellation of losses in the semi-conductors) during permanent state (see Fig. N68). Additionally that concept allows to reduce the current peak at the switch-on in a ratio 4 to 5.



- [a] “zero crossing” contactor iCT+
- [b] “standard” contactor iCT
- [c] impulse relay iTL
- [d] remote controlled MCB

Fig. N68 Examples of control devices (Schneider Electric brand)

4.8.3 Overload of the neutral conductor

The risk

LED luminaires and fluorescent tubes with electronic ballasts are characterized as nonlinear loads, generating harmonic currents. When a number of such luminaires are supplied between phase and neutral on a 3-phase circuit, the 3rd harmonics (and multiples of 3) in each phase are adding together in the neutral, which can cause an overload of the neutral conductor. Fig. N69 below gives an overview of typical H3 level created by lighting.

Lamp type	Typical power	Setting mode	Typical H3 level
Incandescend lamp with dimmer	100 W	Light dimmer	5 to 45 %
ELV halogen lamp	25 W	Electronic ELV transformer	5 %
Fluorescent tube	100 W	Magnetic ballast	10 %
	< 25 W	Electronic ballast	8 %
	> 25 W	+ PFC	30 %
Discharge lamp	100 W	Magnetic ballast	10 %
		Electronic ballast	30 %
Led lamps	10 to 200 W	Electrical driver	10 to 20 %

Fig. N69 Overview of typical H3 level created by lighting

The solution

Firstly, the use of a neutral conductor with a small cross-section (half) should be prohibited, as requested by Installation standard IEC 60364, section 523–5–3.

The effects concern the thermal consequences on switchgear and controlgear, cables and equipment. They are due to harmonic levels maintained for durations equal to or greater than 10 minutes.

As far as overcurrent protection devices are concerned, it is necessary to provide 4-pole circuit breakers with protected neutral (except with the TN-C system for which the PEN, a combined neutral and protection conductor, should not be cut). This type of device can also be used for the breaking of all poles necessary to supply luminaires at the phase-to-phase voltage in the event of a fault.

A breaking device should therefore interrupt the phase and Neutral circuit simultaneously.

4 Lighting circuits

4.8.4 Leakage currents to earth

The risk

At switch-on, the earth capacitances of the electronic ballasts or driver are responsible for residual current peaks that are likely to cause unintentional tripping of protection devices.

Two solutions

The use of Residual Current Devices providing immunity against this type of impulse current is recommended, even essential, when equipping an existing installation (see Fig. N70).

For a new installation, it is sensible to provide zero crossing devices (contactors or impulse relay) that reduce these impulse currents (activation on voltage passage through zero).

4.8.5 Sensitivity of lighting devices to line voltage disturbances

Short interruptions

■ The risk

Discharge lamps require a relighting time of a few minutes after their power supply has been switched off.

■ The solution

Partial lighting with instantaneous relighting (incandescent lamps, LED lamps or fluorescent tubes, or “hot restrike” discharge lamps) should be provided if safety requirements so dictate. Its power supply circuit is, depending on current regulations, usually distinct from the main lighting circuit. LED lighting is also an alternative to overcome that constraint

Voltage fluctuations

■ The risk

The majority of lighting devices (with the exception of lamps supplied by electronic ballasts) are sensitive to rapid fluctuations in the supply voltage. These fluctuations cause a flicker phenomenon which is unpleasant for users and may even cause significant problems. These problems depend on both the frequency of variations and their magnitude.

Standard IEC 61000-2-2 (“compatibility levels for low-frequency conducted disturbances”) specifies the maximum permissible magnitude of voltage variations as a function of the number of variations per second or per minute.

These voltage fluctuations are caused mainly by high-power fluctuating loads (arc furnaces, welding machines, starting motors).

■ The solution

Special methods can be used to reduce voltage fluctuations. Nonetheless, it is advisable, wherever possible, to supply lighting circuits via a separate line supply.

The use of electronic ballasts is recommended for demanding applications (hospitals, clean rooms, inspection rooms, computer rooms, etc).

4.8.6 Developments in control and protection equipment

The use of light dimmers is more and more common. The constraints on ignition are therefore reduced and derating of control and protection equipment is less important.

New protection devices adapted to the constraints on lighting circuits are being introduced, for example Schneider Electric brand circuit breakers and modular residual current circuit breakers with special immunity, such as s.i. type ID switches and Vigi circuit breakers. As control and protection equipment evolves, some now offer remote control, 24-hour management, lighting control, reduced consumption, etc.

PE110815.eps



Fig. N70 s.i. residual current devices with immunity against impulse currents (Schneider-Electric brand)

4 Lighting circuits

Modular contactors and impulse relays do not use the same technologies. Their rating is determined according to different standards and does not correspond to the rated current of the circuit.
 For example, for a given rating, an impulse relay is more efficient than a modular contactor for the control of light fittings with a strong inrush current, or with a low power factor (non-compensated inductive circuit).

4.9 Other lamp technologies - choice of contactor according to lamp type

For LED lamps, see "[LED lamps - choice of contactors](#)".

Fig. N71 shows the maximum number of light fittings for each relay, according to the type, power and configuration of a given lamp.

- These values are given for a 230 V circuit with 2 active conductors (single-phase phase/neutral or two-phase phase/phase). For 110 V circuits, divide the values in the table by 2.
- To obtain the equivalent values for the whole of a 230 V three-phase circuit, multiply the number of lamps and the total acceptable power:
- by $\sqrt{3}$ (1.73) for circuits with 230 V between phases without neutral,
- by 3 for circuits with 230 V between phase and neutral or 400 V between phases.
- The power ratings of the lamps most commonly used are shown in bold. For powers not mentioned, use a proportional rule with the nearest values.
- The total acceptable power values mentioned (such as "1550 W to 2000 W" for incandescent lamps - iCT 16A contactor) are provided as an indication only. The minimum value is for the smallest lamp power (1550 W, corresponding to 38 x 40W LED lamps), the maximum value for the highest lamp power.

Products Type of lamp	iCT contactors								iCT+ contactors	
	Maximum number of light fittings for a single-phase circuit and maximum power output per circuit									
	16 A		25 A		40 A		63 A		20 A	
Basic incandescent lamps, LV halogen lamps, replacement mercury vapour lamps (without ballast)										
	40 W	38	1550 W	57	2300 W	115	4600 W	172	6900 W	4660 W x Cos φ
	60 W	30	to	45	to	85	to	125	to	
	75 W	25	2000 W	38	2850 W	70	5250 W	100	7500 W	
	100 W	19		28		50		73		
ELV 12 or 24 V halogen lamps										
With ferromagnetic transformer	20 W	15	300 W	23	450 W	42	850 W	63	1250 W	
	50 W	10	to	15	to	27	to	42	to	
	75 W	8	600 W	12	900 W	23	1950 W	35	2850 W	
	100 W	6		8		18		27		
With electronic transformer	20 W	62	1250 W	90	1850 W	182	3650 W	275	5500 W	
	50 W	25	to	39	to	76	to	114	to	
	75 W	20	1600 W	28	2250 W	53	4200 W	78	6000 W	
	100 W	16		22		42		60		
Fluorescent tubes with starter and ferromagnetic ballast										
1 tube without compensation ^[a]	15 W	22	330 W	30	450 W	70	1050 W	100	1500 W	
	18 W	22	to	30	to	70	to	100	to	
	20 W	22	850 W	30	1200 W	70	2400 W	100	3850 W	
	36 W	20		28		60		90		
	40 W	20		28		60		90		
	58 W	13		17		35		56		
	65 W	13		17		35		56		
	80 W	10		15		30		48		
1 tube with parallel compensation ^[a]	15 W	5 μF	15	200 W	20	300 W	40	600 W	60	900 W
	18 W	5 μF	15	to	20	to	40	to	60	to
	20 W	5 μF	15	800 W	20	1200 W	40	2400 W	60	3500 W
	36 W	5 μF	15		20		40		60	
	40 W	5 μF	15		20		40		60	
	58 W	7 μF	10		15		30		43	
	65 W	7 μF	10		15		30		43	
	80 W	7 μF	10		15		30		43	
2 or 4 tubes with series compensation	115 W	16 μF	5		7		14		20	
	2 x 18 W		30	1100 W	46	1650 W	80	2900 W	123	4450 W
	4 x 18 W		16	to	24	to	44	to	68	to
	2 x 36 W		16	1500 W	24	2400 W	44	3800 W	68	5900 W
	2 x 58 W		10		16		27		42	
	2 x 65 W		10		16		27		42	
2 x 80 W		9		13		22		34		
2 x 115 W		6		10		16		25		
Fluorescent tubes with electronic ballast										
1 or 2 tubes	18 W	74	1300 W	111	2000 W	222	4000 W	333	6000 W	
	36 W	38	to	58	to	117	to	176	to	
	58 W	25	1400 W	37	2200 W	74	4400 W	111	6600 W	
	2 x 18 W		36		55		111		166	
	2 x 36 W		20		30		60		90	
	2 x 58 W		12		19		38		57	

Fig. N71 Maximum number of light fittings for each relay, according to the type, power and configuration of a given lamp

4 Lighting circuits

iTL impulse relays				iTL+ impulse relays		Reflex iC60 (C curve)									
Maximum number of light fittings for a single-phase circuit and maximum power output per circuit															
16 A		32 A		16 A		10 A		16 A		25 A		40 A		63 A	
40	1500 W	106	4000 W	3680 W x Cos φ	28	1120 W	46	1840 W	70	2800 W	140	5600 W	207	8280 W	
25	to	66	to		23	to	36	to	55	to	103	to	152	to	
20	1600 W	53	4200 W		29	2175 W	31	2600 W	46	3600 W	80	6800 W	121	9800 W	
16		42			15		23		33		60		88		
70	1350 W	180	3600 W		11	220 W	19	380 W	27	540 W	50	1000 W	75	1500 W	
28	to	74	to		8	to	12	to	19	to	33	to	51	to	
19	1450 W	50	3750 W		7	500 W	10	800 W	14	1050 W	27	2200 W	43	3300 W	
14		37			5		8		10		22		33		
60	1200 W	160	3200 W		47	940 W	74	1480 W	108	2160 W	220	4400 W	333	6660 W	
25	to	65	to		19	to	31	to	47	to	92	to	137	to	
18	1400 W	44	3350 W		15	1200 W	24	2000 W	34	2600 W	64	5100 W	94	7300 W	
14		33			12		20		26		51		73		
83	1250 W	213	3200 W		16	244 W	26	390 W	37	555 W	85	1275 W	121	1815 W	
70	to	186	to		16	to	26	to	37	to	85	to	121	to	
62	1300 W	160	3350 W		16	647 W	26	1035 W	37	1520 W	85	2880 W	121	4640 W	
35		93			15		24		34		72		108		
31		81			15		24		34		72		108		
21		55			9		15		21		43		68		
20		50			9		15		21		43		68		
16		41			8		12		19		36		58		
11		29			6		9		12		24		38		
60	900 W	160	2400 W		11	165 W	19	285 W	24	360 W	48	720 W	72	1080 W	
50		133			11	to	19	to	24	to	48	to	72	to	
45		120			11	640 W	19	960 W	24	1520 W	48	2880 W	72	4080 W	
25		66			11		19		24		48		72		
22		60			11		19		24		48		72		
16		42			8		12		19		36		51		
13		37			8		12		19		36		51		
11		30			8		12		19		36		51		
7		20			4		7		9		17		24		
56	2000 W	148	5300 W		23	828 W	36	1296 W	56	2016 W	96	3456 W	148	5328 W	
28		74			12	to	20	to	29	to	52	to	82	to	
28		74			12	1150 W	20	1840 W	29	2760 W	52	4600 W	82	7130 W	
17		45			8		12		20		33		51		
15		40			8		12		20		33		51		
12		33			7		11		15		26		41		
8		23			5		8		12		20		31		
80	1450 W	212	3800 W		56	1008 W	90	1620 W	134	2412 W	268	4824 W	402	7236 W	
40	to	106	to		28	to	46	to	70	to	142	to	213	to	
26	1550 W	69	4000 W		19	1152 W	31	1798 W	45	2668 W	90	5336 W	134	8120 W	
40		106			27		44		67		134		201		
20		53			16		24		37		72		108		
13		34			9		15		23		46		70		

N45

4 Lighting circuits

Products		iCT contactors						iCT+ contactors				
Type of lamp		Maximum number of light fittings for a single-phase circuit and maximum power output per circuit										
		16 A		25 A		40 A		63 A		20 A		
Compact fluorescent lamps												
With external electronic ballast	5 W	210	1050 W	330	1650 W	670	3350 W	Not tested		4660 W x Cos φ		
	7 W	150	to	222	to	478	to					
	9 W	122	1300 W	194	2000 W	383	4000 W					
	11 W	104		163		327						
	18 W	66		105		216						
	26 W	50		76		153						
With integral electronic ballast (replacement for incandescent lamps)	5 W	160	800 W	230	1150 W	470	2350 W	710	3550 W			
	7 W	114	to	164	to	335	to	514	to			
	9 W	94	900 W	133	1300 W	266	2600 W	411	3950 W			
	11 W	78		109		222		340				
	18 W	48		69		138		213				
	26 W	34		50		100		151				
Low-pressure sodium vapour lamps with ferromagnetic ballast with external ignitor												
Without compensation ^[a]	35 W	5	270 W	9	320 W	14	500 W	24	850 W			
	55 W	5	to	9	to	14	to	24	to			
	90 W	3	360 W	6	720 W	9	1100 W	19	1800 W			
	135 W	2		4		6		10				
	180 W	2		4		6		10				
With parallel compensation ^[b]	35 W	20 μF	3	100 W	5	175 W	10	350 W	15	550 W		
	55 W	20 μF	3	to	5	to	10	to	15	to		
	90 W	26 μF	2	180 W	4	360 W	8	720 W	11	1100 W		
	135 W	40 μF	1		2		5		7			
	180 W	45 μF	1		2		4		6			
High-pressure sodium vapour lamps												
Metal-iodide lamps												
With ferromagnetic ballast with external ignitor, without compensation ^[a]	35 W	16	600 W	24	850 W	42	1450 W	64	2250 W			
	70 W	8		12	to	20	to	32	to			
	150 W	4		7	1200 W	13	2000 W	18	3200 W			
	250 W	2		4		8		11				
	400 W	1		3		5		8				
	1000 W	0		1		2		3				
With ferromagnetic ballast with external ignitor and parallel compensation ^[b]	35 W	6 μF	12	450 W	18	650 W	31	1100 W	50	1750 W		
	70 W	12 μF	6	to	9	to	16	to	25	to		
	150 W	20 μF	4	1000 W	6	2000 W	10	4000 W	15	6000 W		
	250 W	32 μF	3		4		7		10			
	400 W	45 μF	2		3		5		7			
	1000 W	60 μF	1		2		3		5			
With electronic ballast	35 W		24	850 W	38	1350 W	68	2400 W	102	3600 W		
	70 W		18	to	29	to	51	to	76	to		
	150 W		9	1350 W	14	2200 W	26	4000 W	40	6000 W		

[a] Circuits with non-compensated ferromagnetic ballasts consume twice as much current for a given lamp power output. This explains the small number of lamps in this configuration.

[b] The total capacitance of the power factor correction capacitors in parallel in a circuit limits the number of lamps that can be controlled by a contactor. The total downstream capacitance of a modular contactor of rating 16, 25, 40 or 63 A should not exceed 75, 100, 200 or 300 μF respectively. Allow for these limits to calculate the maximum acceptable number of lamps if the capacitance values are different from those in the table.

Note: Reflex iC60 - High-pressure sodium vapour lamp with electronic ballast: for the 10 A and 16 A B-curve ratings, the number of lamps should be reduced by 10 % to limit unwanted magnetic tripping.

Fig. N71 Maximum number of light fittings for each relay, according to the type, power and configuration of a given lamp

4 Lighting circuits

iTL impulse relays				iTL+ impulse relays		Reflex iC60 (C curve)									
Maximum number of light fittings for a single-phase circuit and maximum power output per circuit															
16 A		32 A		16 A		10 A		16 A		25 A		40 A		63 A	
240	1200 W	630	3150 W	3680 W x Cos φ	158	790 W	251	1255 W	399	1995 W	810	4050 W	Infrequently used		
171	to	457	to		113	to	181	to	268	to	578	to			
138	1450 W	366	3800 W		92	962 W	147	1560 W	234	2392 W	463	4706 W			
118		318			79		125		196		396				
77		202			49		80		127		261				
55		146			37		60		92		181				
170	850 W	390	1950 W		121	605 W	193	959 W	278	1340 W	568	2840 W	859	4295 W	
121	to	285	to		85	to	137	to	198	to	405	to	621	to	
100	1050 W	233	2400 W		71	650 W	113	1044 W	160	1560 W	322	3146 W	497	4732 W	
86		200			59		94		132		268		411		
55		127			36		58		83		167		257		
40		92			25		40		60		121		182		
Not tested, infrequently used					4	153 W	7	245 W	11	385 W	17	595 W	29	1015 W	
					4	to	7	to	11	to	17	to	29	to	
					3	253 W	4	405 W	8	792 W	11	1198 W	23	2070 W	
					2		3		5		8		12		
					1		2		4		7		10		
38	1350 W	102	3600 W		3	88 W	4	140 W	7	245 W	12	420 W	19	665 W	
24		63			3	to	4	to	7	to	12	to	19	to	
15		40			2	169 W	3	270 W	5	450 W	8	720 W	13	1440 W	
10		26			1		2		3		5		9		
7		18			0		1		2		4		8		
Not tested, infrequently used					12	416 W	19	400 W	28	980 W	50	1750 W	77	2695 W	
					7	to	11	to	15	to	24	to	38	to	
					3	481 W	5	750 W	9	1350 W	15	2500 W	22	4000 W	
					2		3		5		10		13		
					0		1		3		6		10		
					0		0		1		2		3		
34	1200 W	88	3100 W		14	490 W	17	595 W	26	910 W	43	1505 W	70	2450 W	
17	to	45	to		8	to	9	to	13	to	23	to	35	to	
8	1350 W	22	3400 W		5	800 W	6	1200 W	9	2200 W	14	4400 W	21	7000 W	
5		13			3		4		5		10		14		
3		8			2		3		4		7		9		
1		3			0		1		2		4		7		
0		1			0		0		1		2		3		
38	1350 W	87	3100 W		15	525 W	24	840 W	38	1330 W	82	2870 W	123	4305 W	
29	to	77	to		11	to	18	to	29	to	61	to	92	to	
14	2200 W	33	5000 W		6	844 W	9	1350 W	14	2100 W	31	4650 W	48	7200 W	

4 Lighting circuits

4.10 Other lamp technologies - choice of circuit breaker according to lamp type

For LED lamps, see "[LED lamps - choice of circuit breaker](#)".

Fig. N72 below indicates the maximum number of lamps according to the circuit breaker rating, for C-curve circuit breakers

- for B-curve circuit breakers, the number of lamps should be reduced by 50%,
- for D-curve circuit breakers, the number of lamps should be increased by 50%.

Products	Circuit breaker (C curve)						
	10 A	16 A	25 A	40 A	63 A		
Standard incandescent lamps, LV halogen lamps, replacement mercury vapor lamps (without ballast)							
	40 W	28	46	70	140	207	
	60 W	23	36	55	103	152	
	75 W	29	31	46	80	121	
	100 W	15	23	33	60	88	
ELV 12 or 24 V halogen lamps							
Ferromagnetic transformer	20 W	11	19	27	50	75	
	50 W	8	12	19	33	51	
	75 W	7	10	14	27	43	
	100 W	5	8	10	22	33	
Electronic transformer	20 W	47	74	108	220	333	
	50 W	19	31	47	92	137	
	75 W	15	24	34	64	94	
	100 W	12	20	26	51	73	
Fluorescent tubes with starter and ferromagnetic ballast							
1 tube without compensation ^[a]	15 W	16	26	37	85	121	
	18 W	16	26	37	85	121	
	20 W	16	26	37	85	121	
	36 W	15	24	34	72	108	
	40 W	15	24	34	72	108	
	58 W	9	15	21	43	68	
	65 W	9	15	21	43	68	
	80 W	8	12	19	36	58	
	115 W	6	9	12	24	38	
	1 tube with parallel compensation ^[b]	15 W 5 µF	11	19	24	48	72
		18 W 5 µF	11	19	24	48	72
20 W 5 µF		11	19	24	48	72	
36 W 5 µF		11	19	24	48	72	
40 W 5 µF		11	19	24	48	72	
58 W 7 µF		8	12	19	36	51	
65 W 7 µF		8	12	19	36	51	
80 W 7 µF		8	12	19	36	51	
115 W 16 µF		4	7	9	17	24	
2 or 4 tubes with series compensation		2 x 18 W	23	36	56	96	148
		4 x 18 W	12	20	29	52	82
	2 x 36 W	12	20	29	52	82	
	2 x 58 W	8	12	20	33	51	
	2 x 65 W	8	12	20	33	51	
	2 x 80 W	7	11	15	26	41	
	2 x 115 W	5	8	12	20	31	
Fluorescent tubes with electronic ballast							
1 or 2 tubes	18 W	56	90	134	268	402	
	36 W	28	46	70	142	213	
	58 W	19	31	45	90	134	
	2 x 18 W	27	44	67	134	201	
	2 x 36 W	16	24	37	72	108	
	2 x 58 W	9	15	23	46	70	
Compact fluorescent lamps							
External electronic ballast	5 W	158	251	399	810	Infrequent use	
	7 W	113	181	268	578		
	9 W	92	147	234	463		
	11 W	79	125	196	396		
	18 W	49	80	127	261		
	26 W	37	60	92	181		

Fig. N72 Maximum number of lamps according to the circuit breaker rating and curve, for other technologies than LED

4 Lighting circuits

Products		Circuit breaker (C curve)				
Type of lamp		10 A	16 A	25 A	40 A	63 A
Integral electronic ballast (replacing incandescent lamps)	5 W	121	193	278	568	859
	7 W	85	137	198	405	621
	9 W	71	113	160	322	497
	11 W	59	94	132	268	411
	18 W	36	58	83	167	257
	26 W	25	40	60	121	182
Low-pressure sodium vapor lamps with ferromagnetic ballast and external ignitor						
Without compensation ^[a]	35 W	4	7	11	17	29
	55 W	4	7	11	17	29
	90 W	3	4	8	11	23
	135 W	2	3	5	8	12
	180 W	1	2	4	7	10
With parallel compensation ^[b]	35 W 20 µF	3	4	7	12	19
	55 W 20 µF	3	4	7	12	19
	90 W 26 µF	2	3	5	8	13
	135 W 40 µF	1	2	3	5	9
	180 W 45 µF	0	1	2	4	8
High-pressure sodium vapor lamps						
Metal-iodide lamps						
Ferromagnetic ballast with external ignitor, without compensation ^[a]	35 W	12	19	28	50	77
	70 W	7	11	15	24	38
	150 W	3	5	9	15	22
	250 W	2	3	5	10	13
	400 W	0	1	3	6	10
	1000 W	0	0	1	2	3
Ferromagnetic ballast and external ignitor, with parallel compensation ^[b]	35 W 6 µF	14	17	26	43	70
	70 W 12 µF	8	9	13	23	35
	150 W 20 µF	5	6	9	14	21
	250 W 32 µF	3	4	5	10	14
	400 W 45 µF	2	3	4	7	9
	1000 W 60 µF	0	1	2	4	7
Electronic ballast	2000 W 85 µF	0	0	1	2	3
	35 W	15	24	38	82	123
	70 W	11	18	29	61	92
	150 W	6	9	14	31	48

[a] Circuits with non-compensated ferromagnetic ballasts consume twice as much current for a given power output. This explains the small number of lamps in this configuration.

[b] The total capacitance of the power factor capacitors in parallel on a circuit limits the number of lamps that can be controlled by a contactor. The total downstream capacitance of a modular contactor of rating 16, 25, 40 or 63 A should not exceed 75, 100, 200 or 300 µF respectively. Allow for these limits to calculate the maximum acceptable number of lamps if the capacitance values are different from those in the table.

High-pressure sodium vapor lamps: for the 10 A and 16 A B-curve ratings, the number of lamps should be reduced by 10% to limit unwanted magnetic tripping.

Fig. N72 Maximum number of lamps according to the circuit breaker rating and curve, for other technologies than LED

4 Lighting circuits

4.11 Lighting of “building accessible to the public”

Normal lighting

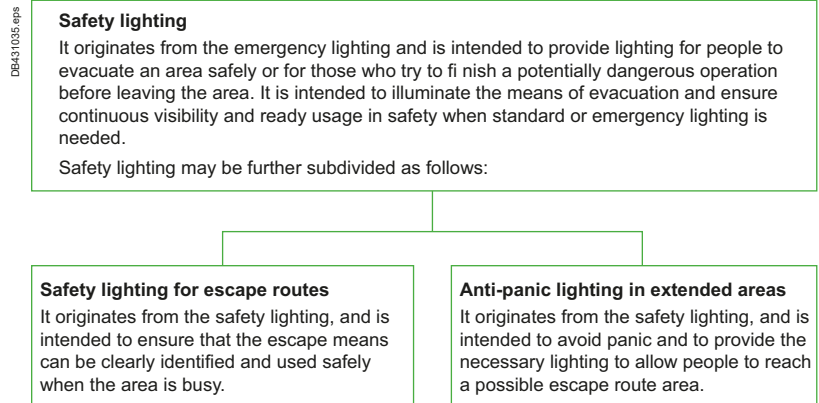
Regulations governing the minimum requirements for buildings receiving the public in most European countries are as follows:

- Installations which illuminates areas accessible to the public must be controlled and protected independently from installations providing illumination to other areas
- Loss of supply on a final lighting circuit (i.e. fuse blown or CB tripped) must not result in total loss of illumination in an area which is capable of accommodating more than 50 persons
- Protection by Residual Current Devices (RCD) must be divided amongst several devices (i.e. more than one device must be used)

Emergency lighting and other systems

When we refer to emergency lighting, we mean the auxiliary lighting that is triggered when the standard lighting fails.

Emergency lighting is subdivided as follows (EN-1838):



Emergency lighting and safety signs for escape routes

The emergency lighting and safety signs for escape routes are very important for all those who design emergency systems. Their suitable choice helps improve safety levels and allows emergency situations to be handled better. Standard EN 1838 ("Lighting applications. Emergency lighting") gives some fundamental concepts concerning what is meant by emergency lighting for escape routes:

"The intention behind lighting escape routes is to allow safe exit by the occupants, providing them with sufficient visibility and directions on the escape route ..."

The concept referred to above is very simple:

The safety signs and escape route lighting must be two separate things.

Functions and operation of the luminaires

The manufacturing specifications are covered by standard EN 60598-2-22, "Particular Requirements - Luminaires for Emergency Lighting", which must be read with EN 60598-1, "Luminaires – Part 1: General Requirements and Tests".

Duration

A basic requirement is to determine the duration required for the emergency lighting. Generally it is 1 hour but some countries may have different duration requirements according to statutory technical standards.

Operation

We should clarify the different types of emergency luminaires:

- Non-maintained luminaires
 - The lamp will only switch on if there is a fault in the standard lighting
 - The lamp will be powered by the battery during failure
 - The battery will be automatically recharged when the mains power supply is restored
- Maintained luminaires
 - The lamp can be switched on in continuous mode
 - A power supply unit is required with the mains, especially for powering the lamp, which can be disconnected when the area is not busy
 - The lamp will be powered by the battery during failure.

4 Lighting circuits

Design

The integration of emergency lighting with standard lighting must comply strictly with electrical system standards in the design of a building or particular place.

All regulations and laws must be complied with in order to design a system which is up to standard (see Fig. N73).

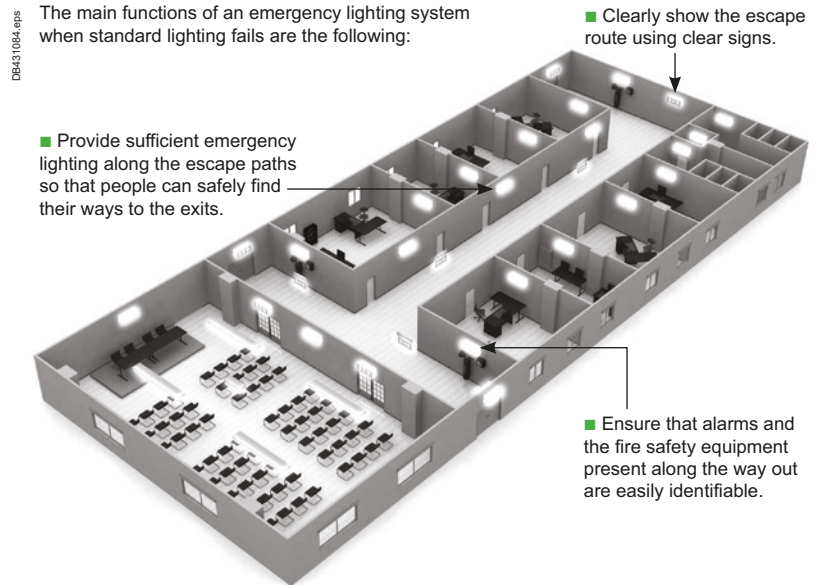


Fig. N73 The main functions of an emergency lighting system

European standards

The design of emergency lighting systems is regulated by a number of legislative provisions that are updated and implemented from time to time by new documentation published on request by the authorities that deal with European and international technical standards and regulations.

Each country has its own laws and regulations, in addition to technical standards which govern different sectors. Basically they describe the places that must be provided with emergency lighting as well as its technical specifications. The designer's job is to ensure that the design project complies with these standards.

EN 1838

A very important document on a European level regarding emergency lighting is the Standard EN 1838, "Lighting applications. Emergency lighting".

This standard presents specific requirements and constraints regarding the operation and the function of emergency lighting systems.

CEN and CENELEC standards

With the CEN (Comité Européen de Normalisation) and CENELEC standards (Comité Européen de Normalisation Electrotechnique), we are in a standardised environment of particular interest to the technician and the designer. A number of sections deal with emergencies. An initial distinction should be made between luminaire standards and installation standards.

EN 60598-2-22 and EN-60598-1

Emergency lighting luminaires are subject to European standard EN 60598-2-22, "Particular Requirements - Luminaires for Emergency Lighting", which is an integrative text (of specifications and analysis) of the Standard EN-60598-1, Luminaires – "Part 1: General Requirements and Tests".

5 Asynchronous motors

The asynchronous (i.e. induction) motor is robust and reliable, and very widely used. 95% of motors installed around the world are asynchronous. The protection of these motors is consequently a matter of great importance in numerous applications.

Asynchronous motors are used in a wide variety of applications. Here are some examples of driven machines:

- air handlers,
- chillers,
- elevators,
- fans and blowers,
- fire pump,
- centrifugal pumps,
- compressors,
- crushers,
- conveyors,
- lifts and cranes,
- ...

The consequence of a motor failure due to an incorrect protection or inability of control circuit to operate can include the following:

- For persons:
 - Asphyxiation due to the blockage of motor ventilation
 - Electrocutation due to insulation failure in the motor
 - Accident due to non stopping of the motor following a control circuit failure
- For the driven machine and the process:
 - Shaft couplings, axles, driving belts, ... damaged due to a stalled rotor
 - Lost production
 - Delayed manufacturing
- For the motor itself:
 - Motor windings burnt out due to stalled rotor
 - Cost of repair
 - Cost of replacement

Therefore, safety of persons and goods, as well as reliability and availability levels, are highly dependant on the selection of protective equipment. In economic terms, the overall cost of failure must be considered. This cost is increasing with the size of the motor and with the difficulties of access and replacement. Loss of production is a further and evidently important factor. Specific features of motor performance influence the power supply circuits required for satisfactory operation

A motor power-supply circuit presents certain constraints not normally encountered in other (common) distribution circuits. These are owing to the particular characteristics of motors directly connected to the line, such as:

- High start-up current (see Fig. N74) which is mostly reactive, and can therefore be the cause of important voltage drop
- Number and frequency of start-up operations are generally high
- The high start-up current means that motor overload protective devices must have operating characteristics which avoid tripping during the starting period.

DB422689_EN.eps

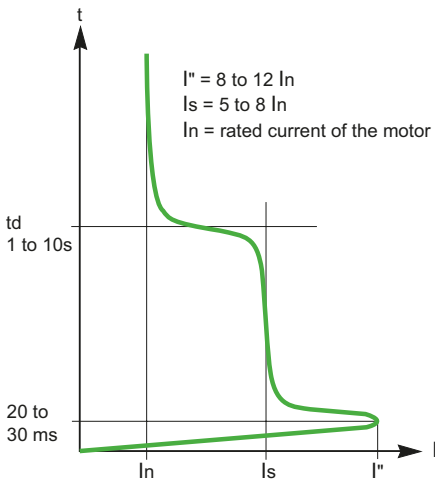


Fig. N74 Direct on-line starting current characteristics of an induction motor

5.1 Motor control systems

Different kinds of motor control solution are compared in the following tables.

	I_s / I_n	T_s / T_n	Speed control	Torque control
Direct on line	5-10	5-10	No	No
Star – Delta	2-3	1-2	No	No
Auto-transformer	2-3	1-2	No	No
Soft starter	3-5	1.5-2.5	No	Yes
Variable speed drive	1.5	1.5-2	Yes	Yes

	Pros	Cons
Direct on line	Reduced cost high starting torque	High in-rush current
Star – Delta	Reduced in-rush current	High in-rush current
Auto-transformer	Reduced in-rush current	High weight
Soft starter	Reduced in-rush current controlled start and stop	Reduced starting torque
Variable speed drive	Controlled speed Energy saving at reduced speed	Higher cost

Fig. N75 Comparison of different motor control solutions

N52

5 Asynchronous motors

5.2 Motor protection functions

These are the arrangements implemented in order to avoid operation of motors in abnormal conditions which could result in negative events such as: overheating, premature ageing, destruction of electrical windings, damage to coupling or gear box, ...

Four levels of protection schemes are commonly proposed: "Conventional", "Advanced", "Advanced Plus", and "High Performance", which can be adopted depending on the sophistication and power of the driven machine.

- "Conventional" protection functions apply for every type of motor or application,
- "Advanced" protection functions apply to more sophisticated machines requesting special attention,
- "Advanced Plus", and "High performance" protection functions are justified for high power motors, high demanding applications, or motors in critical process or whenever ground current must be measured with high accuracy (~0,01A).

As shown in the following figure: "High performance" protections are not based only on current but also on voltage

Protection	Conventional	Advanced	Advanced Plus	High Performance
Short-circuit / Instantaneous overcurrent				
Thermal overload				
Phase current imbalance				
Phase current loss				
Over-current (instantaneous and temporised)				
Ground fault / Instantaneous earth fault				
Long start (stall) / Incomplete sequence				
Jam (locked rotor)				
Under-current				
Phase current reversal				
Motor temperature (by sensors)				
Rapid cycle lock-out / Locking out				
Load shedding				
Notching or jogging / Number of starts				
Phase voltage imbalance				
Phase voltage loss				
Phase voltage reversal				
Under-voltage				
Over-voltage				
Under-power				
Over-power				
Under power factor				
Over power factor				
Motor reclosing				

Fig. N76 Classification of protection functions

5 Asynchronous motors

Here is a list of motor protection functions and the result of activation.

Short-circuit: disconnection in case of a short-circuit at the motor terminals or inside the motor windings.

Instantaneous overcurrent: operates with no intentional time delay when the current exceeds a preset value.

Thermal overload: disconnection of motor in case of sustained operation with a torque exceeding the nominal value. Overload is detected by measurement of excessive stator current or by using PTC probes.

Phase current imbalance: disconnection of the motor in case of high current imbalance, responsible for increased power losses and overheating.

Phase current loss: disconnection of the motor if one phase current is zero, as this is revealing of cable or connection breaking.

Over-current: alarm or disconnection of the motor in case of high phase current, revealing a shaft over-torque.

Ground fault / Instantaneous earth fault: disconnection in case of a fault between a motor terminal and ground. Even if the fault current is limited, a fast action could avoid a complete destruction of the motor. It can be measured with the sum of the 3 phases if the accuracy required is not high (~ 30%). If high accuracy is required then it must be measured with a ground CT (0.01A accuracy).

Long start (stall): disconnection in case of a starting time longer than normal (due to mechanical problem or voltage sag) in order to avoid overheating of the motor.

Jam: disconnection in order to avoid overheating and mechanical stress if motor is blocked while running because of congestion.

Undercurrent: alarm or disconnection of the motor in case a low current value is detected, revealing a no-load condition (e.g.: pump drain, cavitation, broken shaft, ...)

Phase current reversal: disconnection when a wrong phase current sequence is detected

Motor temperature (by sensors): alarm or disconnection in case of high temperature detected by probes.

Rapid cycle lock-out: prevent connection and avoid overheating due to too frequent start-up.

Load shedding: disconnection of the motor when a voltage drop is detected, in order to reduce the supply load and return to normal voltage.

Notching or jogging / Number of starts: a specified number of successive operations within a given time.

Phase voltage imbalance: disconnection of the motor in case of high voltage imbalance, responsible for increased power losses and overheating.

Phase voltage loss: disconnection of motor if one phase of the supply voltage is missing. This is necessary in order to avoid a single-phase running of a three-phase motor, which results in a reduced torque, increased stator current, and inability to start.

Phase voltage reversal: prevent the connection and avoid the reverse rotation of the motor in case of a wrong cabling of phases to the motor terminals, which could happen during maintenance for example.

Under-voltage: prevent the connection of the motor or disconnection of the motor, as a reduced voltage could not ensure a correct operation of the motor.

Over-voltage: prevent the connection of the motor or disconnection of the motor, as an increased voltage could not ensure a correct operation of the motor.

Under-power: alarm or disconnection of the motor in case of power lower than normal, as this situation is revealing a pump drain (risk of destruction of the pump) or broken shaft.

Over-power: alarm or disconnection of the motor in case of power higher than normal, as this situation is revealing a machine overload.

Under power factor: can be used for detection of low power with motors having a high no-load current.

Over power factor: can be used for detection of end of the starting phase.

Motor reclosing: controls the automatic reclosing and locking out of a motor.

5 Asynchronous motors

The consequence of abnormal overheating is a reduced isolation capacity of the materials, thus leading to a significant shortening of the motor lifetime. This is illustrated on Fig. N77, and justifies the importance of overload or over-temperature protection.

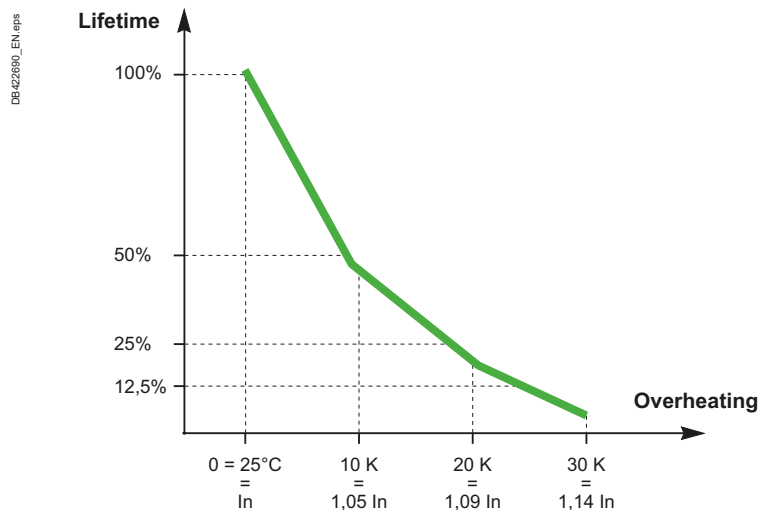


Fig. N77 Reduced motor lifetime as a consequence of overheating

Overload relays (thermal or electronic) protect motors against overloads, but they must allow the temporary overload caused by starting, and must not trip unless the starting time is abnormally long.

Depending on the application, the motor starting time can vary from a few seconds (for no-load starting, low resistive torque, etc.) to several tens of seconds (for a high resistive torque, high inertia of the driven load, etc.). It is therefore necessary to fit relays appropriate to the starting time.

To meet this requirement, IEC Standard 60947-4-1 defines several classes of overload relays, each characterized by its tripping curve (see Fig. N78).

The relay rating is to be chosen according to the nominal motor current and the calculated starting time.

Trip class 10 is adapted to normal duty motors.

Trip class 20 is recommended for heavy duty motors

Trip class 30 is necessary for very long motor starting.

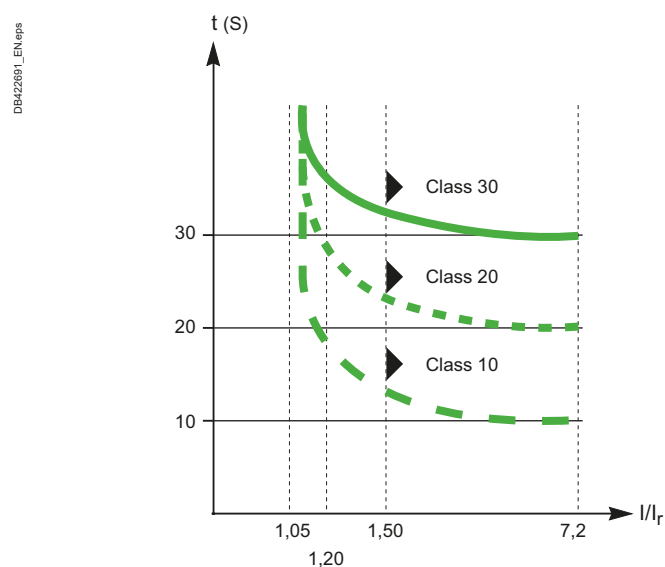


Fig. N78 Tripping curves of overload relays

5 Asynchronous motors

5.3 Motor monitoring

The objective of implementing measurement devices is to ensure a continuous supervision of operating conditions of motors. The collected data can be used with great benefit for improving Energy Efficiency, extending lifetime of motors, or for programming maintenance operations.

Four levels of sophistication for monitoring scheme are commonly proposed: «Conventional», «Advanced», «Advanced Plus», and «High Performance», which can be made accessible, depending on the sophistication and power of the driven machine and the criticality of the process.

Measurement	Conventional	Advanced	Advanced Plus	High Performance
Line currents				
Ground current				
Average current				
Phase current imbalance				
Thermal capacity level				
Motor temperature (by sensors)				
Frequency				
Phase to phase voltage				
Phase voltage imbalance				
Average voltage				
Active power				
Reactive power				
Power factor				
Active energy				
Reactive energy				

Fig. N79 Classification of monitoring functions

PB116817 eps

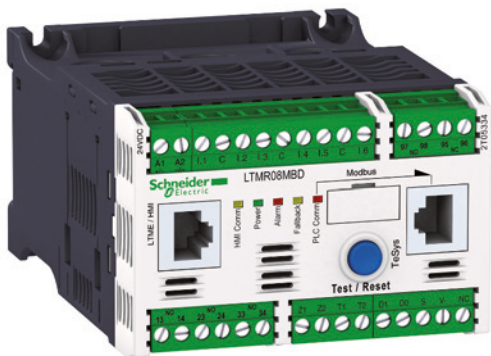


Fig. N80 Example of intelligent motor management system with “Advanced Plus” and “High performance” protection and monitoring functions (TeSys T Schneider Electric)

Here is a list of the most useful variables to be monitored, and the benefit provided by the measurement.

Line Currents: they are directly responsible for the conductors heating and thus for a possible time life reduction. These are the most important variables to monitor. The current measurement also gives a direct indication on the motor load and stress applied to the driven machine.

Ground current: It can be measured with the sum of the 3 phases if the accuracy required is not high (~ 30%). If high accuracy is required then it must be measured with a ground CT (0.01A accuracy).

Average current: to know the average load of the motor, whether the motor is well adapted to the driven machine or not.

Phase current imbalance: as imbalance is responsible for additional losses in the motor, phase current imbalance is an important variable to monitor.

Thermal capacity level: knowledge of the remaining overload capability and safety margin.

Motor temperature (by sensors): knowledge of the real thermal operating conditions, taking into account the motor load, ambient temperature, ventilation efficiency.

Frequency: measures current at 47-63 Hz fundamental frequency. Value measured based on the line voltage measurements. If the frequency is unstable (+/- 2 Hz variations), the value reported will be 0 until the frequency stabilizes.

Phase to phase voltage: too high or too low phase voltages are responsible of increased motor current for a given load. Voltage monitoring is thus indicating whether the motor is operating in normal conditions or not.

Phase voltage imbalance: as imbalance is responsible for additional losses in the motor, phase voltage imbalance is an important variable to monitor.

Active power: indication of the load level applied to the motor.

Reactive power: indication of the reactive power that could be necessary to compensate by implementation of capacitors.

Power factor: indication of load level of the motor. If Power Factor is > 1: submit your candidacy for the Physics Nobel Prize.

Active energy: possibility to relate the consumed energy to the operating time or the quantity of goods produced by driven machine.

Reactive energy: possibility to determine the necessity of implementation of capacitors in order to avoid payment of penalties to the Utility.

5 Asynchronous motors

5.4 Motor starter configurations

Motor controllers come in different types and configurations determined by many variables within an application. It is increasingly common for a process, machine or equipment such as HVAC to integrate the controller and the motor.

This enables the machine manufacture to add more value and control more of the solution, therefore minimizing risk associated with external coordination.

Some examples are shown on **Fig. N81**.

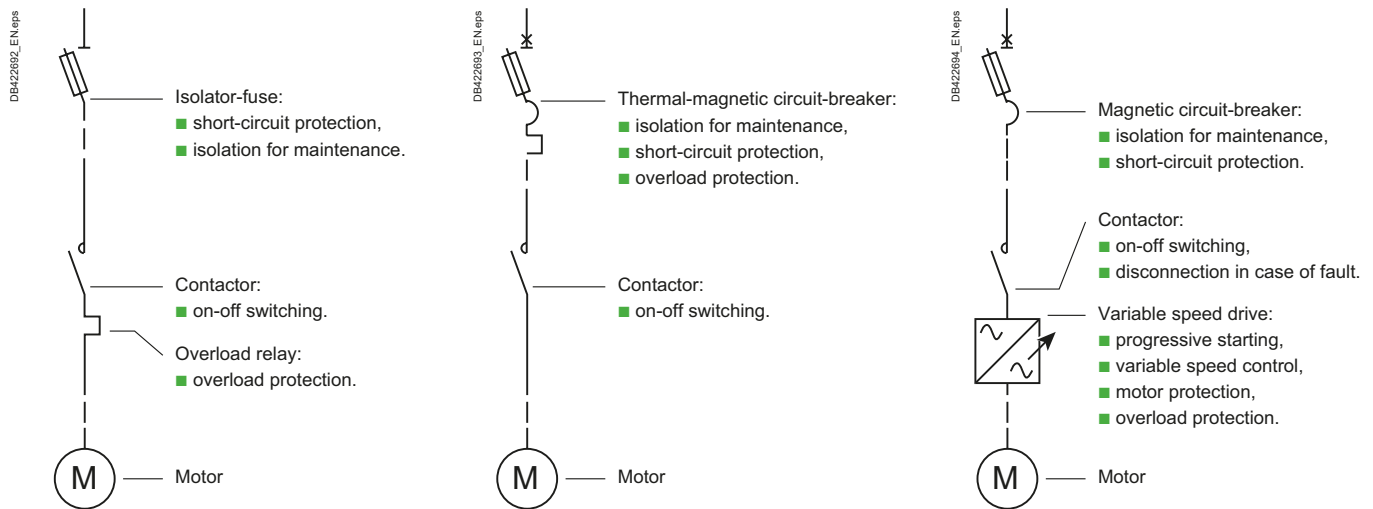


Fig. N81 The various functions and their combinations forming a motor starter

Direct on line (DOL) starting

A direct on line (DOL) or across the line starter, the simplest type of motor starter, applies the full line voltage to the motor terminals.

DOL starting is sometimes used to start small water pumps, compressors, fans and conveyor belts. In the case of an asynchronous motor, such as the 3-phase squirrel-cage motor, the motor will draw a high starting current until it has run up to full speed. This starting current is typically 6-7 times greater than the full load current.

To reduce the inrush current, larger motors will have reduced-voltage starters or variable speed drives in order to minimize voltage dips to the power supply.

Soft starters

A motor soft starter is a device used with AC electrical motors to temporarily reduce the load and torque in the power train and electric current surge of the motor during start-up. This reduces the mechanical stress on the motor and shaft, as well as the electrodynamic stresses on the attached power cables and electrical distribution network, extending the lifespan of the system.

The motor is adjusted to the machine's load by controlling the three-phase motor's voltage supply during the start-up phase. Equipment is accelerated smoothly, this lengthens service life, improves operating behavior, and smooths work flows. Electrical soft starters can use solid state devices to control the current flow and therefore the voltage applied to the motor.

Soft starters are more expensive than DOL starters, but they are widely used due to their convenience and simplicity.

5 Asynchronous motors

Variable frequency drives

A variable-frequency drive (VFD; variable speed drive, AC drive) is a type of adjustable-speed drive used in electro-mechanical drive systems to control AC motor speed and torque by varying motor input frequency and voltage. VFDs are used in applications ranging from small appliances to large compressors.

The VFD controller is a solid-state power electronics conversion system consisting of three distinct sub-systems: a rectifier bridge converter, a direct current (DC) link, and an inverter. Most drives are AC-AC drives in that they convert AC line input to AC inverter output.

A VFD is extremely versatile and often used in process applications where a constant pressure or flow needs to be maintained. In addition, because the motor can be run at a slower speed and hence use less energy, use of a VFD can facilitate significant power savings.

Variable speed drives are generally the most expensive method of motor starting, but their versatility means they are very widely used.

Applicable standards

The different applicable standards are listed on **Fig. N82**.

Standard	Title
IEC 60947-1	Low-voltage switchgear and controlgear – General rules
IEC 60947-4-1	Contactors and motor-starters – Electromechanical contactors and motor-starters
IEC 60947-4-2	Contactors and motor-starters – AC semiconductor motor controllers and starters
IEC 60947-6-2	Multiple function equipment – Control and protective switching devices (or equipment) (CPS)
IEC 61800	Adjustable speed electrical power drive systems

Fig. N82 Applicable standards

Different utilization categories have been defined for contactors in IEC 60947-4-1. The selection relative to asynchronous motor control is given in **Fig. N83**.

Category	Typical applications
AC-1	Non-inductive or slightly inductive loads, resistance furnaces
AC-2	Slip-ring motors: starting, switching off
AC-3	Squirrel-cage motors: starting, switching off motors during running
AC-4	Squirrel-cage motors: starting, plugging ^[a] , inching ^[b]
IEC 61800	Adjustable speed electrical power drive systems

[a] By plugging is understood stopping or reversing the motor rapidly by reversing motor primary connections while the motor is running.

[b] By inching (jogging) is understood energizing a motor once or repeatedly for short periods to obtain small movements of the driven mechanism

Fig. N83 Different categories of AC contactors used for asynchronous motor control

5 Asynchronous motors

5.5 Protection coordination

Type 1 and Type 2 coordination are defined in IEC 60947-4-1.

Total coordination is offered by some manufacturers.

Coordination	Consequence of a short circuit	Application field
Type 1	The contactor or starter shall cause no danger to persons and installation and may not be suitable for further service without repair and replacement of parts.	General purpose application. Basic machines.
Type 2	The contactor or starter shall cause no danger to persons or installation and shall be suitable for further use. The risk of contact welding is recognized, in which case the manufacturer shall indicate the measures to be taken as regards the maintenance of the equipment.	Process with availability constraints, e.g.: continuous process, critical industrial machines.
Continuity of service (total coordination)	No damage or maladjustment is permissible. Must be able to restart immediately after fault is corrected No special precaution is required.	

Fig. N84 Level of acceptable destruction according to the coordination types

Among the many possible methods of protecting a motor, the association of a circuit breaker + contactor + thermal relay^[1] provides many advantages

5.6 Basic protection scheme: circuit breaker + contactor + thermal relay

The combination of these devices facilitates installation work, as well as operation and maintenance, by:

- The reduction of the maintenance work load: the circuit breaker avoids the need to replace blown fuses and the necessity of maintaining a stock (of different sizes and types)
- Better continuity performance: the installation can be re-energized immediately following the elimination of a fault and after checking of the starter
- Additional complementary devices sometimes required on a motor circuit are easily accommodated
- Tripping of all three phases is assured (thereby avoiding the possibility of “single phasing”)
- Full load current switching possibility (by circuit breaker) in the event of contactor failure, e.g. contact welding
- Interlocking
- Diverse remote indications
- Better protection for the starter in case of over-current and in particular for impedant short-circuit^[2] corresponding to currents up to about 30 times I_n of motor (see Fig. N85)
- Possibility of adding RCD:
 - Prevention of risk of fire (sensitivity 500 mA)
 - Protection against destruction of the motor (short-circuit of laminations) by the early detection of earth fault currents (sensitivity 300 mA to 30 A).

[1] The combination of a contactor with a thermal relay is commonly referred to as a “discontactor”.

[2] In the majority of cases, short circuit faults occur at the motor, so that the current is limited by the cable and the wiring of starter and are called impedant short-circuits.

5 Asynchronous motors

DE422695_EN.eps

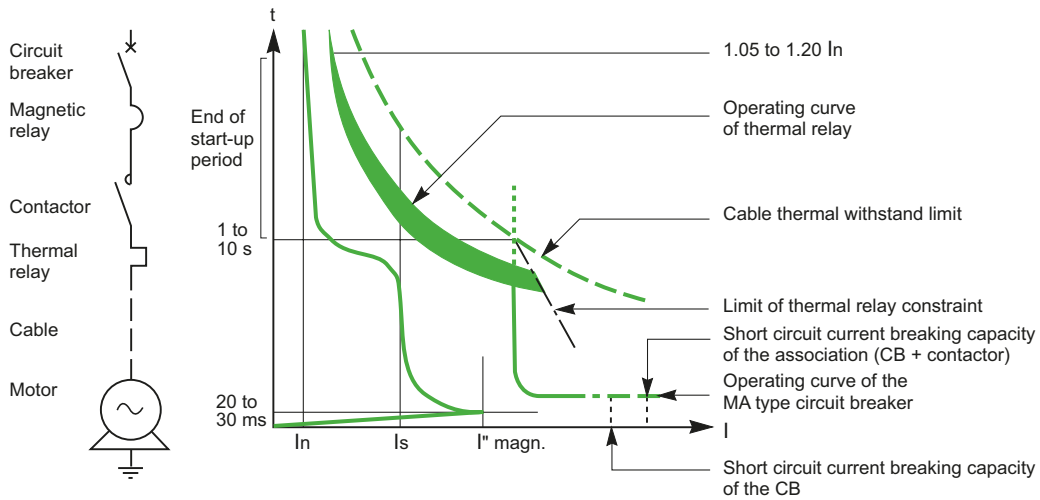


Fig. N85 Tripping characteristics of a circuit breaker + contactor + thermal relay

The combination of a circuit breaker + contactor + thermal relay for the control and protection of motor circuits is eminently appropriate when:

- The maintenance service for an installation is reduced, which is generally the case in tertiary and small and medium sized industrial sites
- The job specification calls for complementary functions
- There is an operational requirement for a load breaking facility in the event of need of maintenance.

5.7 Control and protection switching gear (CPS)

CPS or “starter-controllers” are designed to fulfil control and protection functions simultaneously (overload and short-circuit). In addition, they are designed to carry out control operations in the event of short-circuit.

They can also assure additional functions such as insulation, thereby totally fulfilling the function of “motor starter unit”. They comply with standard IEC 60947-6-2, which notably defines the assigned values and utilisation categories of a CPS, as do standards IEC 60947-1 and 60947-4-1. The functions performed by a CPS are combined and coordinated in such a way as to allow for uptime at all currents up to the I_{cs} working short circuit breaking capacity of the CPS. The CPS may or may not consist of one device, but its characteristics are assigned as for a single device. Furthermore, the guarantee of “total” coordination of all the functions ensures the user has a simple choice with optimal protection which is easy to implement.

Although presented as a single unit, a CPS can offer identical or greater modularity than the “three product” motor starter unit solution. This is the case with the Schneider Electric “TeSys U” starter-controller (see [Fig. N86](#)).

5 Asynchronous motors

DB422696_EN_eps

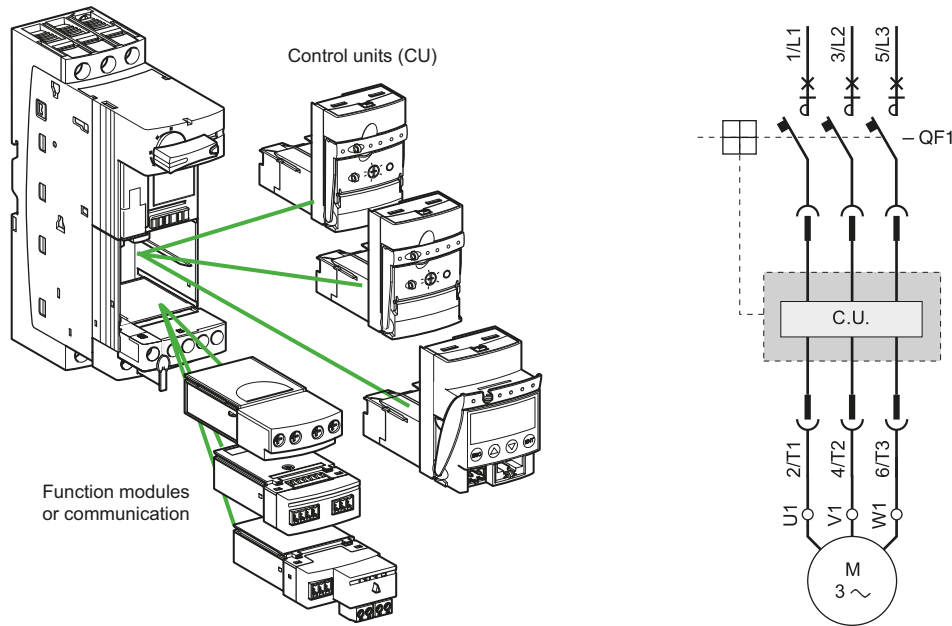


Fig. N86 Example of a CPS modularity (TeSys U starter controller by Schneider Electric)

Additional functionalities can also be installed with regard to:

- Power: reversing block, current limiter,
- Control:
 - Function modules, alarms, motor load monitoring, automatic resetting, etc,
 - Communication options such as Modbus-RTU (a.k.a. SL), Profibus-DP, DeviceNet, CAN-Open, AS-I, etc,
 - Auxiliary contact modules.

Available functions	Standard	Advanced	Multi-function
Starter status (ready, running, with default)			
Start and Stop controls			
Thermal alarm			
Remote resetting by bus			
Indication of motor load			
Defaults differentiation			
Alarms (overcurrents...)			
Parameter setting and protection function reference			
"Log file" function			
"Monitoring" function			

Information conveyed by bus and functions performed

Fig. N87 TeSys U Communication functions

5 Asynchronous motors

5.8 Intelligent Power and Motor Control Centre (iPMCC)

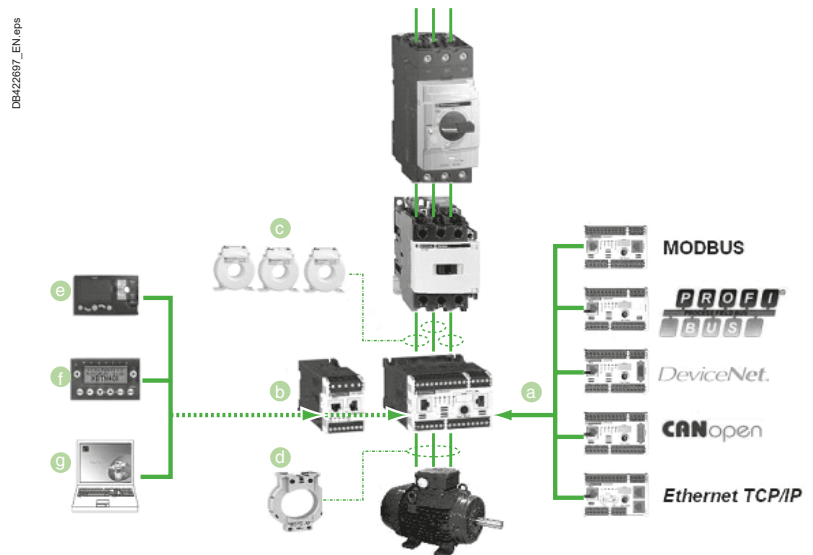
iPMCC is a system integrating intelligent Motor Protection Relays (IMPR) in a highly dependable Power and Motor Control Centre switchboard. Connectivity to the supervision and control system is provided through an industrial communications network.

This solution is particularly used in large industrial sites and infrastructures, with continuous or hybrid process, and whenever continuity of service is a priority.

intelligent Motor Protection Relay (IMPR)

IMPR is the key component of an iPMCC. It is a microprocessor controlled device. Motor monitoring and protection is performed based on measurements from sensors, such as current transformers, voltage transformers (embedded or external), thermal sensor, earth leakage detector, ... From these measurements and the settings, it determines fault conditions or potential risks for motors and operators.

According to the motor protection model, an IMPR has the capability to detect many kinds of faults. It is a great improvement compared to thermal relay protection. Moreover, many complementary functions can be implemented by an IMPR: monitoring, alarming, fault recording, statistics, communications, etc...



[a] Tesys T motor protection relay with native communications capability. The protections are based on current and temperature.

[b] Tesys T extension module integrating voltage measurement and protections.

[c] Tesys T's embedded CT can measure the earth leakage current of 20-500 % of FLC (full load current). External CT can be used to get a better accuracy (0.02-10A).

[d] [e] [f] [g] Different kinds of Human Machine Interfaces (1-to-1, 1-to-8, and 1-to-Many).

Fig. N88 Example of motor control and protection architecture

Motor Control Centre

A Motor Control Centre (MCC) is an electrical switchboard which groups all motor starters of a process, in order to build a centralised installation. Motor starters management centralisation is requested in many industries and infrastructures, in order to facilitate operation and maintenance. Withdrawable MCC functional units (FU), a.k.a. drawers, are used in critical applications, as they are more convenient to manage in case of fault. The faulty motor starter can be replaced quickly, without shutting down the whole switchboard.

Fixed or disconnectable FUs can be used in less critical applications.

MCC-type ASSEMBLIES must be full-compliant to IEC 61439-1 and 61439-2 standards to guarantee availability, safety and reliability of the application. In an iPMCC configuration, design verification, especially temperature rise test, is essential because the IMPR (electronic device) is sensitive to heat. Furthermore, MCC should provide a dependable and reliable communication bus connection

An MCC is different from a universal cabinet in the way that a universal cabinet can only be used to accommodate a group of few motor starters. It has lower electrical characteristics requirements, and it does not provide the separation between motor starters in different functional units. Therefore, in an universal cabinet complete shutdown will be necessary before maintenance operations or any reconfiguration of the starters.

5 Asynchronous motors

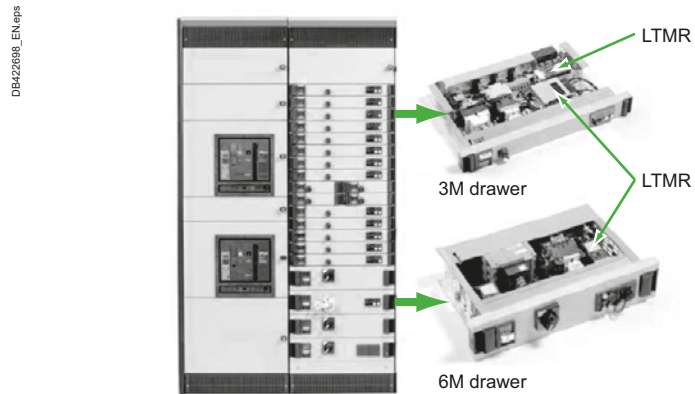


Fig. N89 Example of iPMCC: Okken switchboard and drawers by Schneider Electric

Compared to traditional solutions, an iPMCC offers great advantages in both the project design and execution stage as well as at the operations stage.

Value proposition for contractors during the project stage:

- It improves project efficiency
 - Reduction of engineering work, as starters are more standardised over a wider range of ratings,
 - Reduction of on-site wiring time thanks to the use of field buses,
 - Reduction of set-up time thanks to remote parametrization of control motor devices.
- It reduces commissioning time by
 - Allowing a better understanding of the process reactions thanks to detailed diagnostics and statistics,
 - Allowing faster error fixing and bug tracking,
 - Helping to fix process start-up problems,
 - Allowing time reduction thanks to pre-validated solutions (reference architectures).

Value proposition for end users during the operation stage:

- Improved Continuity of Service
 - Increase process availability by better PROTECTING the motors & the loads,
 - Using more accurate sensors,
 - Using more accurate motor protection models.
- Reduced untimely DOWNTIME
 - Alarms often give time to fix the problem before tripping occurs,
 - Trip conditions are detailed to help corrective operations,
 - Statistics can be used for continuous improvement,
 - Recording all protection parameters changes.
- Reduced Operational Costs
 - Reduced ENERGY costs,
 - Reduced energy consumption,
 - Optimised energy consumption, benchmarking, costs allocation.
- Reduced MAINTENANCE costs
 - Less downtime,
 - Faster problem fixing,
 - Less spare parts stock,
 - Preventive maintenance strategy.
- Reduced EVOLUTION costs and time
 - Simplified engineering,
 - No wiring required,
 - Simplified set-up,
 - Easier process tuning and commissioning.

5 Asynchronous motors

A complete iPMCC concentrates the knowledge and experience of electrical distribution, motor protection and control, automation and installation. This is why only a few leading companies in electrical distribution and automation can propose this kind of solution.

5.9 Communication

Lots of data are managed in an iPMCC application. An iPMCC application is typically made of 50 to 1000 motor starters. In order to supervise the system, it is necessary to send the motors's information such as motor status, current value, alarm, etc.

The traditional wire-to-wire connection is not an efficient and cost-effective way when there is a lot of data to be transmitted.

Today, communications via a network is the preferred way.

For an introduction on communication media, topologies, protocols ... please refer to "[Introduction to communication networks for electrical distribution](#)".

1	Trends and benefits of photovoltaic energy	P2
	1.1 Worldwide growth of solar PV	P2
	1.2 Decentralization of electricity production	P2
	1.3 Self consumption on the rise	P2
	1.4 Access to energy	P3
2	Background and technology	P4
	2.1 The photovoltaic effect	P4
	2.2 Photovoltaic modules	P5
	2.3 Inverters.....	P7
	2.4 Connections	P8
3	PV System and Installation Rules	P9
	3.1 How to ensure safety during normal operation?	P9
	3.2 Protection against overvoltage: Surge protection	P12
	3.3 How to ensure safety during maintenance or emergency	P13
	3.4 How to ensure safety during all the life cycle of the installation.....	P13
4	PV installation architectures	P14
	4.1 Common characteristics of PV architectures.....	P14
	4.2 PV System architectures	P15
	4.3 Sizing	P17
	4.4 Installation type	P18
	4.5 Electrical equipments selection	P19
	4.6 Connection of PV system to the grid or to the private low voltage installation	P23
5	PV architectures for self-consumption	P24
	5.1 PV system connection to the electrical installation.....	P24
	5.2 Operation of electrical installation with local PV production	P28
	5.3 Architecture and equipment requirements.....	P29
	5.4 Guidelines for sizing.....	P30
6	Monitoring	P32
	6.1 PV installations for commercial and industrial buildings	P32
	6.2 Utility scale power plants	P33

1 Trends and benefits of photovoltaic energy

1.1 Worldwide growth of solar PV

This technology enables electricity to be produced directly from sunlight, which is a source of renewable energy.

Photovoltaic (PV) energy is one of the most promising technologies addressing the global challenge of climate degradation and meeting the pressing need for green renewable energy and sustainable development. PV energy production has several benefits: solar energy is unlimited, is available worldwide, does not emit greenhouse gases (GHG) or other pollutants during operation, and consumes little or no water. PV panels are silent producers and require little maintenance. In addition, producing energy from the sun reduces the dependence on energy imports, and over the long term should improve the security of energy supply and stabilize the cost of electricity generation.

Pushed by sustainable energy policies, extensive country engagement, technology development, and cost reduction, today's installed PV capacity is growing rapidly. By 2016, cumulative PV capacity reached 303GW compared to only 40GW in 2010.

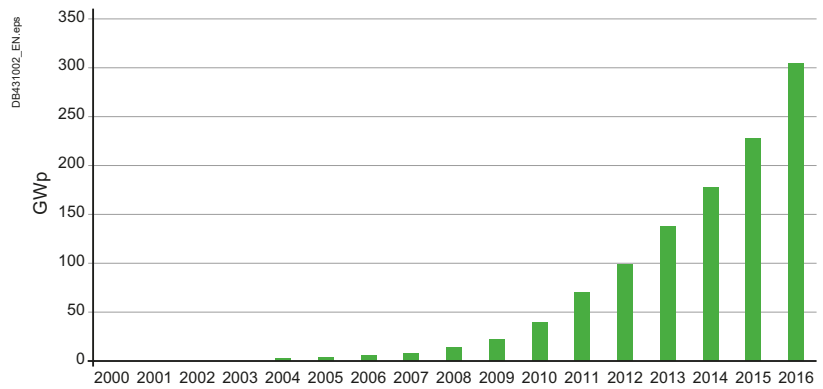


Fig. P1 Installed photovoltaic capacity through 2016. Source: IEA-PVPS 2016 Snapshot of global Photovoltaic markets, April 2017

1.2 Decentralization of electricity production

PV installations are usually split into two main categories:

- **Large utility-scale PV installations**, which typically inject all electricity production into the grid. Utility-scale PV installations are more cost-effective due to their scale. As the number of large utility-scale PV installations is growing, the new grid codes require them to support the grid and assure its stability
- **Commercial and residential installations** (rooftop, car park or building integrated) where produced energy can be consumed locally or sold back to the grid. These installations represent the half of the installed PV capacity today.

1.3 Self consumption on the rise

There are two main options for photovoltaic energy use:

- Export it to the grid
- Self consumption

The exporting-to-the-grid option offers a long-term contract with guaranteed rates for exported PV energy (feed-in tariff policy).

This model was popular in the past because it was supported by a massive subsidized campaign to expand solar energy deployment. With the decrease of PV system costs and the increase of PV installed capacity, feed-in-tariff rates have progressively decreased in many countries, becoming even lower than end-user electricity rates. When that is the case, self-consumption becomes more profitable, and thus progressively replaces exporting to the grid for residential, commercial, and industrial buildings.

1 Trends and benefits of photovoltaic energy

The trends for feed-in-tariff, price, and cost of electricity in Germany are shown in Fig. P2. In 2006, an industrial customer in Germany was paid roughly 40 cents per kWh for selling its PV energy production, buying its electricity at the much lower tariff of around 10 cents per kWh. Exporting the PV production was financially advantageous and this option was preferred. Ten years later, in 2016, the tariff for selling the PV energy is lower than the electricity rate, so self-consumption is more profitable.

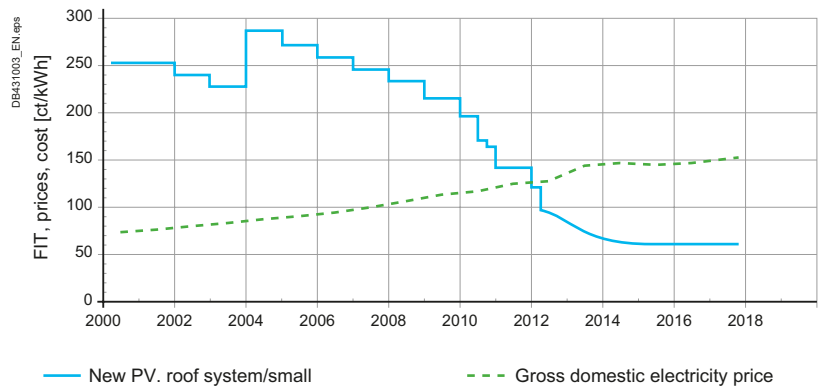


Fig. P2 Evolution of feed-in-tariff rates and electricity price in Germany.
Source: Recent Facts about Photovoltaics in Germany, Fraunhofer ISE, 2017

Self-consumption is the economic model where the residential, commercial, or industrial entity uses the generated PV electricity to cover its own electricity needs, thus acting as both producer and consumer, or prosumer. The solar energy being produced is consumed instantaneously.

If and when the generated PV electricity exceeds the prosumer's consumption, several options exist to give value to the PV production excess: it can be injected into the grid; it can be stored and used in deferred time; or prosumer consumption can be shifted to fit the PV production.

Self-consumption is the model promoted and supported today by a growing number of countries because it makes energy consumers active players in the energy transition and contributes to meeting the objective of increasing the share of renewable in the energy mix.

Prosumers also prefer the self-consumption model for several reasons:

- It offers, or will offer in the near future, the greatest economic benefits
- It allows prosumers to consume their own solar energy
- It provides better control of energy bills
- It promises greater future independence from the grid and electricity rate variations

1.4 Access to energy

Photovoltaic energy production remains one of the only means of supplying electricity to 2 billion people who currently do not have access to it.

This is a massive way of supplying electricity, independent of any network. In order to size these off-grid installations correctly, it is first necessary to identify the required load curve and the number of days where the installation will not be exposed to sunlight in order to identify how much energy needs to be stored in batteries. This information is used to determine the size and type of batteries required.

Then, the surface area of the photovoltaic sensors must be calculated to ensure that the batteries can be recharged in the worst case scenario (shortest day of the year).

2 Background and technology

PE11620_EN.eps

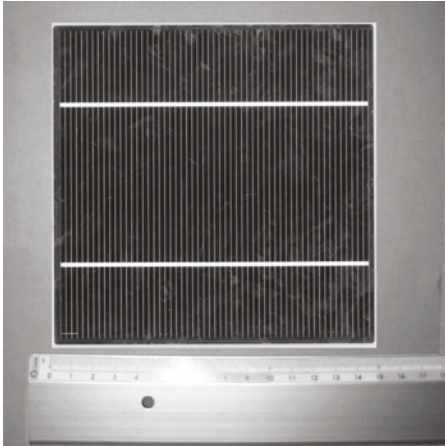


Fig. P3 Photovoltaic cell manufactured in a silicon plate (source: Photowatt)

2.1 The photovoltaic effect

This is the ability to transform solar energy into electricity and is achieved by using photovoltaic (PV) cells.

A PV cell (see **Fig. P3**) is capable of generating voltage of between 0.5 V and 2 V depending on the materials used and a current directly dependent on the surface area (5 or 6 inch cells).

Its characteristics are shown in a current/voltage graph as shown in **Fig. P4**.

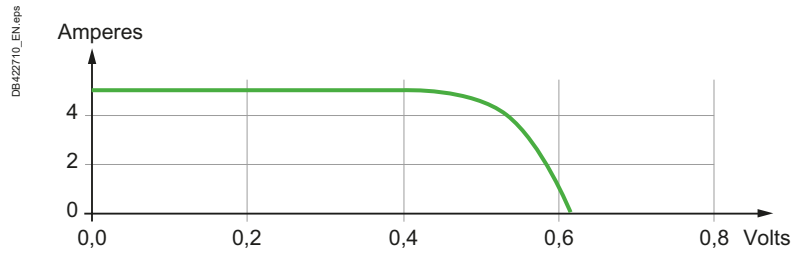


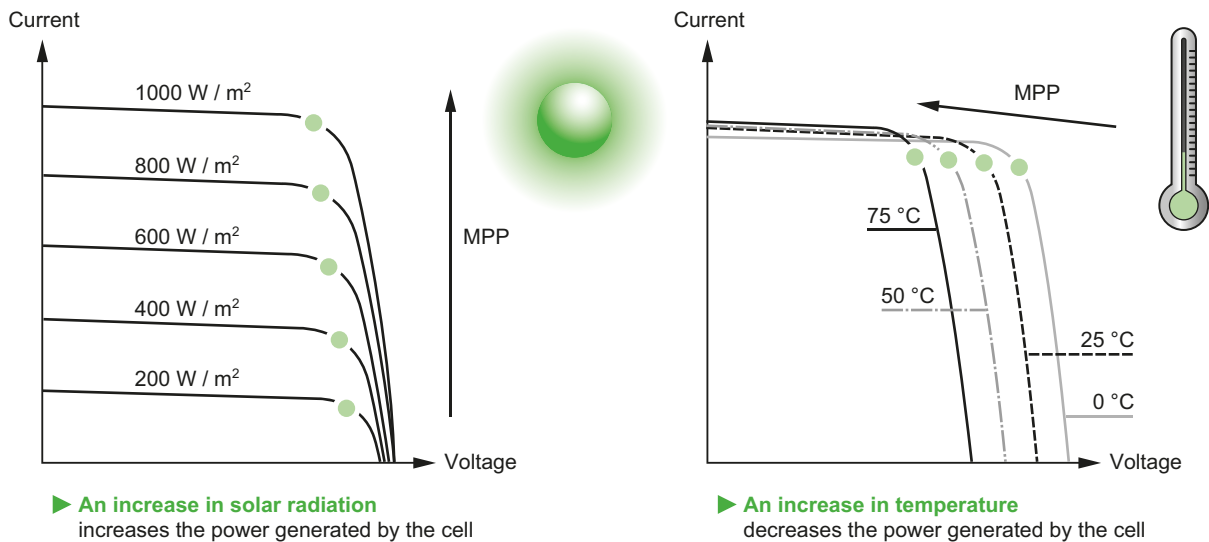
Fig. P4 Typical characteristic of a photovoltaic cell

The photovoltaic effect is dependent on two physical values (see **Fig. P5**) – irradiance and temperature:

- As irradiance E (W/m^2) increases, so do the current and power produced by the cell
- As the temperature (T°) of the cell increases, the output voltage decreases significantly, the current increases only slightly, so overall the output power decreases. In order to compare the performance of different cells, the standard has set out Standard Test Conditions (STC) for irradiance of $1000 W/m^2$ at $25^\circ C$.

To make it easier to use energy generated by photovoltaic cells, manufacturers offer serial and/or parallel combinations grouped into panels or modules.

DB42711_EN.eps



► An increase in solar radiation increases the power generated by the cell

► An increase in temperature decreases the power generated by the cell

MPP : Maximum Power Point

Fig. P5 Irradiance and temperature influence the photovoltaic effect

2 Background and technology

PB116821_L EN.esa

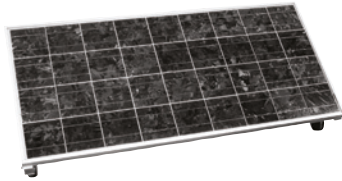


Fig. P6 PW2300 photovoltaic module dimensions: 1638 x 982 x 40 mm (source: Photowatt)

2.2 Photovoltaic modules

These combinations of cells (see **Fig. P6**) enable the voltage and current to be increased. To optimise the characteristics of the modules, these are made up of cells with similar electrical characteristics.

Each module providing a voltage of several tens of volts is classified by its power level measured in Watt peak (Wp). This relates to the power produced by a surface area of one m² exposed to irradiation of 1000 W/m² at 25°C. However, identical modules may produce different levels of power. Currently, the IEC standard specifies a power variation of ±3%. Modules with typical power of 160 Wp include all modules with power of between 155 Wp (160 -3%) and 165 Wp (160 +3%).

It is therefore necessary to compare their efficiency which is calculated by dividing their power (W/m²) by 1000 W/m². For example, for a module of 160 Wp with a surface area of 1.338m² [1], the peak power is 160/1.338 which gives 120 Wp/m².

Therefore the efficiency of this module is: 120/1000 = 12%.

Nota: Manufacturers may have different production tolerance limits according to local standards or habits (example: JISC8918 specifies ±10%), so it is recommended to always check product catalogues for actual tolerance values. (see table in **Fig. P7** as an example).

Cell size	156 x 156 mm		
Number of cells	60		
Voltage	24 V		
Typical power	250	255	260
Power tolerance	0/+5	0/+5	0/+5
Voltage at typical power	30.1 V	30.2 V	30.4 V
Current at typical power	8.3 A	8.4 A	8.6 A
Short circuit current	8.9 A	9.0 A	9.1 A
Open circuit voltage	37.2	37.4	37.5
Maximum system voltage	1 000 V CC		
Temperature coefficient	Isc = +0.065%/°C Voc = -0.34%/°C Pmax = -0.43 % /°C		
Power specifications	Under Standard Test Conditions (STC) : irradiance of 1000 W/m ² , spectrum AM 1.5 and cells temperature of 25°C		

Fig. P7 Electrical characteristics of a PW2300 module (source: Photowatt)

However when photovoltaic cells are connected in series, a destructive phenomenon known as the “hot spot” may occur if one of the cells is partially shaded. This cell will operate as a receiver and the current passing through it may destroy it. To avoid this risk, manufacturers include bypass diodes which bypass damaged cells. Bypass diodes are usually fitted in the junction box behind the module and enable 18 to 22 cells to be shunted depending on the manufacturer.

These modules are then connected in series to achieve the level of voltage required, forming chains of modules or “strings”. Then the strings are arranged in parallel to achieve the required level of power, thus forming a PV array.

Since there are increasing numbers of PV module manufacturers throughout the world, it is important to consider the various options carefully when choosing equipment. Installers should also:

- Ensure the compatibility of the electrical characteristics with the rest of the installation (inverter input voltage).
- Ensure that they are compliant with the standards.
- Select suppliers likely to be in business in the long-term to ensure that faulty modules can be replaced as these must be identical to those already installed. This final point is important as installers are responsible for the warranty granted to their clients.

A faulty module within a string must be replaced by an identical module and therefore it is important to choose a supplier which is likely to be in business in the long-term.

[1] The dimensions of these modules (L x W x D) in mm are: 1237 x 1082 x 38.

2 Background and technology

Different technologies are currently being used to manufacture photovoltaic generators. These are divided into two categories - crystalline modules and thin film modules.

Crystalline silicon modules

There are two main categories of crystalline silicon modules – mono-crystalline modules and multi-crystalline modules.

Mono-crystalline modules are currently best in terms of performance, with efficiency of 16 – 18%.

They are also more expensive. The efficiency of multi-crystalline modules is between 12 and 14%. They are more commonly used, especially in the residential and service sectors.

These modules have a service life of more than 20 years. They lose some of their power over time (< 1% per year) but continue to produce electricity. Depending on the look required, bi-glass modules are available with two plates of glass which make the module semi-transparent, or Tedlar or Teflon glass modules which are less expensive but completely opaque.

Thin film modules

Extensive research is currently being carried out on thin film modules and current efficiency levels of 6 to 8% should increase in coming years. They are cheap and suitable for large areas provided that the surface is not a valuable part of the facility. This category of thin film modules includes a number of technologies of which there are 3 main types:

- a-Si – thin film or amorphous silicon
- CdTe (cadmium telluride)
- CIS (copper indium selenide)

It should be noted that at present we do not yet have 20 years' experience of this type of technology and thus still do not know how these modules will age. In their technical specifications, reputable manufacturers indicate initial and stabilised values.

The table in **Fig. P8** provides a comparative overview of all these technologies.

Technologies	sc-Si mono-crystalline	mc-Si multi-crystalline	a-Si Thin film	CdTe Thin film	CIS Thin film
STC module efficiency					
Maximum	20.4 %	16 %	10 %	14.4 %	15.5 %
Average	16 %	15 %	6 %	11 %	11 %
Relative cost (\$/Wp)	0.8 to 1	0.8 to 1	0.75	0.65	0.85
Temperature coefficient at the power peak (%/°C)	-0.3 / -0.5	-0.3 / -0.5	-0.2	-0.2	-0.3

Fig. P8 Comparison of technologies used in photovoltaic generators

2 Background and technology

DSC0795_epps



Fig. P9 Conext CL60-A String inverter for Photovoltaic energy supply

2.3 Inverters

These devices which convert direct current into alternating current are special inverters for photovoltaic power supply (see Fig. P9). Different types of photovoltaic inverters or “PV inverters” are available. They fulfil three main functions:

- Inverter function: Converts direct current into alternating current in the form required (sinusoidal, square, etc.)
- MPPT function: Calculates the operating point on the photovoltaic surface or array which produces the most power in terms of voltage and current - also known as the Maximum Power Point Tracker (see Fig. P10).
- Automatic disconnection from the network function: Automatically commands the inverter to switch off and the system to disconnect from the network in the absence of voltage on the electrical network. This protects the inverter and any maintenance staff who may be working on the network.

Therefore, in the event of a network failure, the inverter no longer supplies energy to the network and energy produced by the photovoltaic modules is wasted. “Grid interactive” systems are nevertheless available which function in back-up mode. Batteries need to be installed for these systems as well as an additional control panel to ensure that the network is disconnected before supplying their own energy.

■ Different models

Some “multi-MPPT” inverters have a double (or triple, quadruple, etc.) MPPT function. This function enables PV supply to be optimised when the array includes strings facing in different directions. There is however a risk of total loss of supply if one inverter is faulty.

Nevertheless, it is possible to install one less powerful inverter per string, which is a more expensive solution but increases the overall reliability of the system.

“Multi-string inverters” are also available. These inverters are not necessarily multi-MPPT as described above. The name simply indicates that several strings can be connected to the inverter and that they are paralleled inside the inverter.

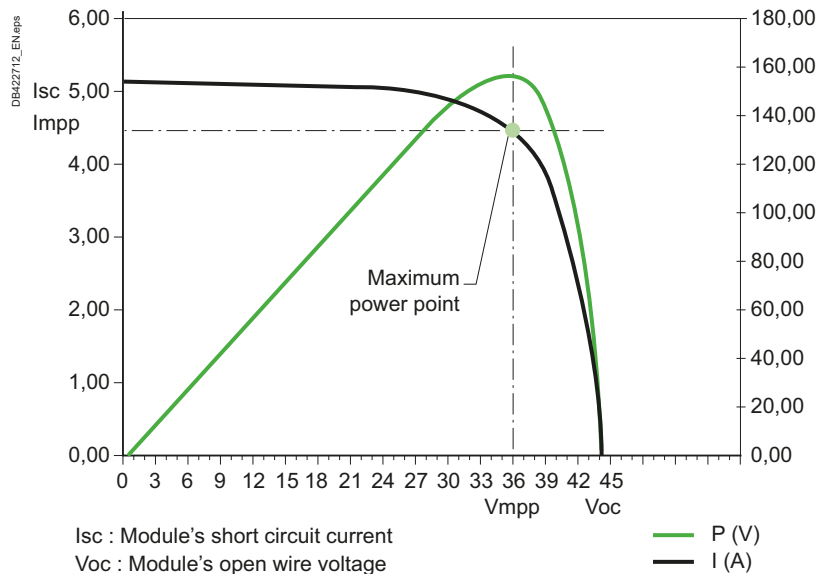


Fig. P10 Operating point of a photovoltaic array which produces the most power, also known as the Maximum Power Point Tracker

European efficiency

In order to compare the various appliances, a level of efficiency has been determined based on different operating points, simulating the average daily performance of an inverter. This “European efficiency” is calculated using the following formula:

$$0.03 \times (\eta \text{ 5\%}) + 0.06 \times (\eta \text{ 10\%}) + 0.13 \times (\eta \text{ 20\%}) + 0.1 \times (\eta \text{ 30\%}) + 0.48 \times (\eta \text{ 50\%}) + 0.2 \times (\eta \text{ 100\%})$$

where:

- (η 5%) (η 10%) ... represent the MPPT static efficiency at 5%, 10% ... partial MPP power.
- 0.03, 0.06 ... are the weighting factors used to calculate this overall «European efficiency», and have been calculated according to yearly climate data (north-western Germany climate data)

Note: another similar efficiency calculation has been defined by California Energy Commission, eg similar formula but using different weighting factors and operating points.

2 Background and technology

We strongly advise against installing an inverter in a place exposed to the sun as this will considerably reduce its service life.

IP and operating temperature

Ingress protection and temperature parameters are important when choosing an inverter.

Almost all manufacturers of inverters offer IP65 inverters which can be installed outdoors. However, this does not mean that they should be installed in full sunlight as most inverters operate in degraded mode in temperatures over 40°C (50°C for Xantrex inverters manufactured by Schneider Electric) and thus output power is reduced.

Installing inverters outdoors in full sunlight also incurs the risk of premature aging of some of the inverter's components such as the chemical condensers. This considerably reduces the inverter's service life from 10 years to as few as 5 years!

2.4 Connections

Photovoltaic installations require special cables and connectors. Since modules are installed outdoors they are subjected to climatic constraints associated with high voltages caused by the installation of modules in series.

Besides being ingress protected, the equipment used must also be resistant to UV rays and ozone. It must furthermore display a high level of mechanical resistance and a high level of resistance to extreme variations in temperature.

Cables

The voltage drop between the PV array and the inverter must be calculated and this must not exceed 3% for nominal current.

The DC cables used should be double-insulated single wire cables and since these are not standardised, cables indicated by the manufacturer as being specifically for PV should be used.

Connectors

In general, photovoltaic modules are supplied with two cables equipped with one male and one female connector. Using these cables, it is possible to connect two modules installed side by side, thus creating a series without any difficulties. The male connector connects to the female connector of the following module and so on until the required level of direct current is reached.

These special connectors with locking systems (for example the Multi-Contact MC3 or MC4 connectors) offer protection if touched while they are disconnected.

This protection is necessary since as soon as a photovoltaic module is exposed to irradiation, it supplies voltage. If the cables connecting the modules are handled (to alter or extend them) they must either first be disconnected or the DC isolator for the DC circuit must be activated at the input to the connection box.

It is also possible to use different connectors available on the market. These should be chosen carefully for their quality, contact and male-female mating to avoid any poor contact which may lead to overheating and destruction

3 PV System and Installation Rules

IEC standard 60364 Part 7-712 sets out rules for ensuring that solar photovoltaic power systems are safe and supplies a number of the definitions used in these pages.

3.1 How to ensure safety during normal operation?

Two particular characteristics of PV generators are their DC voltage levels and the fact they cannot be shut off as long as PV modules are exposed to the sun. The short-circuit current produced by the PV module is too low to trigger the power supply's automatic disconnection. The most frequently used protective measures do not therefore apply to PV systems. However, as PV modules are installed outdoors they are exposed to the elements. And since they can be installed on roofs, critical attention should be paid to the risk of fire and the protection of fire fighters and emergency services staff.

3.1.1 Protecting people against electric shock

IEC 60364-7-712 stipulates that PV systems whose maximum $U_{oc\ MAX}$ ($U_{oc} =$ Open Circuit Voltage) is higher than 120V DC should use « double or reinforced insulation » as a protection against electric shock.

Switchgear, such as fuses or circuit-breakers on the DC side, do not afford protection against electric shock as there is no automatic disconnection of the power supply.

Overcurrent protection, when used, protects PV cells against reverse current and cables against overload.

3.1.2 Risk of fire: protection against thermal effects

Generally speaking there are three situations that can lead to abnormally high temperatures and the risk of fire in a PV system: insulation fault, a reverse current in a PV module, and overloading cables or equipment.

Insulation fault detection

Double or reinforced insulation is a protective measure against electric shock but it does not exclude all risk of insulation fault. (The assumption here is that the likelihood of an insulation fault and of someone touching an energised part of the installation at the same is very low. Insulation faults in themselves do happen more frequently, however.) DC insulation fault could be more dangerous as arc has less chance to extinguish by itself as it does in AC.

The PV generator should be checked to ensure it is insulated from earth.

■ **When there is no galvanic insulation between the AC side and the DC side:**

- It is impossible to earth one pole.
- AC protection can be used to detect insulation faults.

■ **When the AC side and DC side are galvanically separated:**

- An overcurrent protective device (which also detects insulation faults) should be used to trip the grounded conductor in the event of a fault, if the PV cell technology (e.g. thin films of amorphous silicon) requires one of the conductors to be directly grounded.
- An insulation monitoring device should be used if the PV cell technology requires one of the conductors to be resistance-grounded.
- An insulation monitoring device should also be used when PV cell technology does not require either conductor to be earthed.

Insulation monitoring device shall be selected taking into consideration both $U_{oc\ MAX}$ and the capacitance between poles and earth causes leakage current. In addition cables and inverter capacitance should be also considered.

An Insulation monitoring device able to handle capacitance up to 500 μ F is suitable for PV system.

Paragraph 412.1.1 of IEC 60364-4-41 states: Double or reinforced insulation is a protective measure in which

- basic protection is provided by basic insulation, and fault protection is provided by supplementary insulation, or
- basic and fault protection is provided by reinforced insulation between live parts and accessible parts.

NB: This protective measure is intended to prevent the appearance of dangerous voltage on the accessible parts of electrical equipment through a fault in the basic insulation.

When an insulation fault is detected whatever the solution is, inverter is stopped and disconnected from AC side, but the fault is still present on DC side and voltage between poles is open circuit voltage of PV generator as long as sun is shining.

This situation cannot be tolerated over a long period and the fault has to be found and cleared. If not, a second fault may develop on the other pole, causing the current to circulate in the earthing conductors and metal parts of the PV installation with no guarantee that protective devices will operate properly. See "Overcurrent protection".

3 PV System and Installation Rules

The literature provided by manufacturers of photovoltaic modules yield the following figures:

	Maximum power usually developed with a single inverter	Surface necessary to develop such a Power	Usual capacitance by m ²	Usual capacitance between lines and earth for a single IT system
Frameless glass-glass module with aluminium frame on an assembly stand (open air)	1 MW	8000 m ²	1 nF / m ²	8 µF
In-roof glass-glass module with aluminium frame	100 kW	800 m ²	5 nF / m ²	4 µF
Thin-film PV module on flexible substrate	100 kW	800 m ²	50 nF / m ²	40 µF

Some measurements made in European plants are giving the following figures:

	Maximum power developed with a single inverter	Surface required to develop such a Power	Lowest capacitance measurement (sunny afternoon)	Highest capacitance measurement (rainy morning)	Maximum measured capacitance by m ²
Frameless glass-glass module with aluminium frame on an assembly stand (open air)	Plant 1: 1 MW	8000 m ²	5 µF	10 µF	1.25 nF / m ²
	Plant 2: 750 kW	5000 m ²	2 µF	4 µF	0.8 nF / m ²
In-roof glass-glass module with aluminium frame	Plant 1: 100 kW	800 m ²	2 µF	4 µF	5 nF / m ²
	Plant 2: 50 kW	400 m ²	0.5 µF	1 µF	2.5 nF / m ²
Thin-film PV module on flexible substrate	Plant 1: 100 kW	800 m ²	30 µF	50 µF	62.5 nF / m ²
	Plant 2: 50 kW	400 m ²	15 µF	25 µF	62.5 nF / m ²

Fig. P11 Example of leakage capacitance in various PV systems

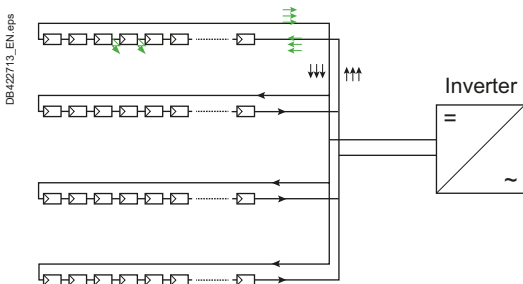


Fig. P12 Reverse current

3.1.3 Protection of PV modules against reverse current

A short circuit in a PV module, faulty wiring, or a related fault may cause reverse current in PV strings. This occurs if the open-circuit voltage of one string is significantly different from the open voltage of parallel strings connected to the same inverter. The current flows from the healthy strings to the faulty one instead of flowing to the inverter and supplying power to the AC network. Reverse current can lead to dangerous temperature rises and fires in the PV module. PV module withstand capability should therefore be tested in accordance with IEC 61730-2 standard and the PV module manufacturer shall provide the maximum reverse current value (IRM)

Reverse current into the faulty string = total current of the remaining strings

String overcurrent protection is to be used if the total number of strings that could feed one faulty string is high enough to supply a dangerous reverse current:

$$1.35 I_{RM} < (N_s - 1) I_{SC MAX}$$

where:

- I_{RM} is the maximum reverse current characteristic of PV cells defined in IEC 61730
- N_s is the total number of strings

There is no risk of reverse current when there is only one string. When there are two strings with same number of PV modules connected in parallel, the reverse current will be always lower than the maximum reverse current. So, when the PV generator is made of one or two strings only there is no need for reverse current protection.

3 PV System and Installation Rules

3.1.4 Protection against overcurrent

As in any installation, there should be protection against thermal effect of overcurrent causing any danger.

Short-circuit current depends on solar irradiance, but it may be lower than the trip value of overcurrent protection. Although this is not an issue for cables as the current is within current-carrying capacity, the inverter will detect a voltage drop and stop producing power. It is therefore recommended that the maximum trip current should be significantly lower than $I_{SC_STC_MAX}$.

String protection (IEC 60364-7-712 2017 712.433.1.101.2)

Where string overcurrent protection is required, each PV string shall be protected with an overcurrent protection device.

The nominal overcurrent protection (Fuse or Circuit breaker) rating of the string overcurrent protection device shall be greater than 1.5 times the string short circuit current I_{SC_MOD} and below $2.4 I_{SC_MOD}$.

Sub-array protection (IEC 60364-7-712 2017 712.433.1.101.3)

The nominal rated trip current (ITRIP) of overcurrent protection devices for PV sub-arrays (Fuses or Circuit breaker) shall be greater than 1.25 times the sub-array short-circuit current $I_{SC_STC_SUB-ARRAY}$ and below $2.4 I_{SC_STC_SUB-ARRAY}$.

The selection of overcurrent protection rating shall be done in order to avoid unexpected trip in normal operation taking into account temperature.

A protection rating higher than 1.4 times the protected string or array short-circuit current I_{SC_STC} is usually recommended.

3.1.5 Circuit breakers or Fuses

Circuit breakers or fuses can be used to provide overcurrent protection.

Fuses, usually on the fuse holder or directly connected to bars or cables, do not provide a load-break switch function. So when fuses are used, load-break switches should also be used to disconnect fuses from the inverter in order to allow cartridge replacement. So an array box with fuses on fuse holders as string protection, for example, should also incorporate a main switch.

Circuit breakers offer fine-tuned adjustment and greater accuracy than fuses in order to allow the use of cables, especially for sub-array cables, that are smaller than fuses.

Double earth faults

PV systems are either insulated from the earth or one pole is earthed through an overcurrent protection. In both set-ups, therefore, there can be a ground fault in which current leaks to the ground. If this fault is not cleared, it may spread to the healthy pole and give rise to a hazardous situation where fire could break out. Even though double insulation makes such an eventuality unlikely, it deserves full attention.

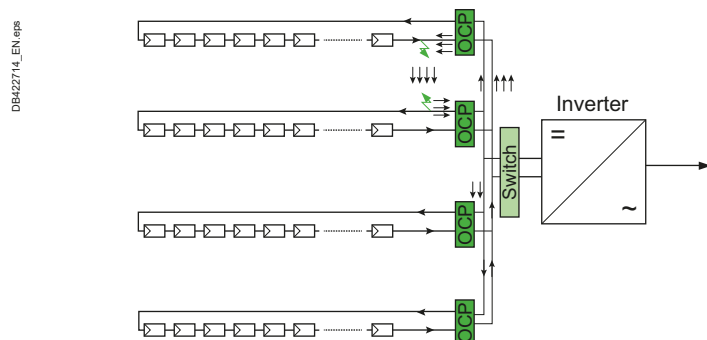


Fig. P13 String overcurrent protection "OCP"

For the two following reasons the double fault situation shall be absolutely avoided: Insulation monitoring devices or overcurrent protection in earthed system shall detect first fault and staff shall look after the first fault and clear it with no delay.

■ The fault level could be low (e.g. two insulation faults or a low short-circuit capability of the generator in weak sunlight) and below the tripping value of overcurrent protection (circuit breaker or fuses). However, a DC arc fault does not spend itself, even when the current is low. It could be a serious hazard, particularly for PV modules on buildings.

3 PV System and Installation Rules

■ Circuit breakers and switches used in PV systems are designed to break the rated current or fault current with all poles at open-circuit maximum voltage ($U_{OC\ MAX}$). To break the current when $U_{OC\ MAX}$ is equal to 1000V, for instance, four poles in series (two poles in series for each polarity) are required. In double ground fault situations, the circuit breaker or switches must break the current at full voltage with only two poles in series. Such switchgear is not designed for that purpose and could sustain irremediable damage if used to break the current in a double ground fault situation.

The ideal solution is prevent double ground faults arising. Insulation monitoring devices or overcurrent protection in grounded systems detect the first fault. However, although the insulation fault monitoring system usually stops the inverter, the fault is still present. Staff must locate and clear it without delay. In large generators with subarrays protected by circuit breakers, it is highly advisable to disconnect each array when that first fault has been detected but not cleared within the next few hours.

3.1.6 Switchgears and enclosure selection

Double insulation

Enclosures on the DC side shall provide double insulation.

Thermal issues

The thermal behaviour of switchgear and enclosures warrants careful monitoring. PV generator boxes and array boxes are usually installed outdoors and exposed to the elements. In the event of high ambient temperatures, high IP levels could reduce air flow and thermal power dissipation. In addition, the way switchgear devices achieve high voltage operation – i.e. through the use of poles in series – increases their temperature. Special attention should therefore be paid to the temperature of switchgear inside outdoor enclosures on the DC side.

Cable protection should comply with requirements of IEC 60364. Part 7-712 of the standard stipulates that all enclosures on the DC side should meet the requirements of IEC 61439. This standard covers low voltage switchgear and control gear assemblies and sets out requirements that guarantee the risk of temperature rises has been factored into the safe design of DC boxes (generator and array boxes).

Pollution degree of switchgear and enclosure selection

In addition to the standard criteria for selecting enclosures in PV systems with $U_{OC\ MAX}$ of 1000V, some equipment may show IEC 60947-1 Pollution Degree 2 rather than Pollution Degree 3.

If the switchgear is Pollution Degree 2, the IP level of the enclosure according to IEC 60529 shall be at least IP5x.

3.2 Protection against overvoltage: Surge protection

See chapter [J paragraph 5.2](#)

3 PV System and Installation Rules

Note: Switches used in PV systems are designed to break the rated current of all poles at U_{OCMAX} . To break the current when U is equal to $1000V$, for instance, four poles in series (two poles in series for each polarity) are required. In double ground fault situations, the circuit breaker or switches must break the current at full voltage with only two poles in series. Such switchgear is not designed for that purpose and could sustain irremediable damage if used to break the current in a double ground fault situation. For this reason double ground faults must be avoided at all costs. Insulation monitoring devices or overcurrent protection in grounded system detect the first fault. Staff shall locate it and clear it without delay.

PB116823.eps



Fig. P14 Switch-disconnector Compact NSX 200A with heatsink and interphase barrier

3.3 How to ensure safety during maintenance or emergency

To ensure staff safety during maintenance and emergencies disconnect devices should be appropriately located and enclosures installation should be failsafe.

3.3.1 Isolation switching and control

- The switch disconnectors on the AC side and DC side of the inverter shall be installed for inverter service and maintenance.
- As many switch disconnectors should be installed as are needed to allow operation on the PV generator, particularly to replace fuses in the String combiner boxes and generator junction boxes.
- For PV systems inside buildings, a remotely-controlled switch disconnector should be mounted as closely as possible to the PV modules or to the point of entry of DC cables in the event of an emergency.

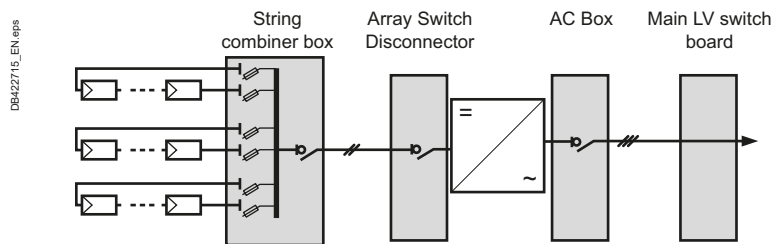


Fig. P15 Switch-disconnector location

3.3.2 Selecting and installing enclosures

Enclosures for different PV generator boxes and switch boards on the DC side need to ensure double isolation, equipment protection against such outdoor hazards as temperatures, the rain, vandalism, and shock. Enclosure and their auxiliary equipment must ensure temperature and humidity control to allow equipment to operate smoothly. It is, however, difficult to propose a generic solution. Each installation needs to be analysed in order to optimize the sizing of its enclosures and auxiliary equipment.

3.4 How to ensure safety during all the life cycle of the installation

IEC60364-6 requires initial and periodic verifications of electrical installations. Specificities of photovoltaic installation (outdoor, high DC voltage, unsupervised installation) make periodic checking very important.

If usually the efficiency of all the system is checked in order to ensure the maximum production, we recommend to perform periodic maintenance of equipment.

PV system operating conditions involve various environmental stresses: wide temperature variations, humidity, and electrical stresses. In order to ensure performances of equipment during all the life cycle of installation particular attention shall be paid to the following:

- Enclosure integrity (Double isolation IP level)
- Switchgears operating condition and integrity
 - to evaluate if any overheating has occurred
 - to examine switchgears for the presence of dust, moisture...
- Visual check of electrical connections
- Functional test of equipment and auxiliaries
- Insulation monitoring device test
- Insulation resistance test

4 PV installation architectures

4.1 Common characteristics of PV architectures

A PV array is made up of a number of modules in series or parallel, corresponding to the input characteristics of the inverter. However, since these modules are interconnected, the array is very sensitive to shade or differences in terms of the direction faced.

By following a few simple cabling rules, supply can be optimised and any operating problems may be avoided.

Position of the panels

If, when installing a PV array on a roof, panels need to face in different directions, it is essential to assemble at least one string per direction and ensure each string is facing in just one direction to ensure optimised supply. Each string must be connected to a specific inverter (or to inputs of a multi-MPPT inverter - see Section 2.3).

If this instruction is not observed, the array will not be damaged but supply will be reduced, thus increasing the time needed for a return on investment.

Shade

Besides the risk of destruction of shaded modules within a PV array due to the “hot spot phenomenon” as described in Paragraph 2.2 for which manufacturers have devised solutions, research conducted by the Institut National des Energies Solaires (INES – France’s national institute for solar energy) suggests that shading of 10% of the surface area of a string may cause more than a 30% reduction in output! It is therefore important to eliminate direct shading. However, in many cases this is difficult (trees, chimney, neighbouring wall, pylon, etc.).

If a PV array includes several strings:

- If possible, shaded modules should be included in a single string
- Otherwise, a technology should be chosen which responds better to diffuse light than direct light

Eliminating loops

When connecting components, the first precaution to take is to avoid loops in the cabling within strings.

Even though direct lightning strikes on arrays are relatively rare, currents induced by lightning are much more common and these currents are particularly destructive where there are large areas of looping. **Fig. P16** shows how to improve an array including a large loop.

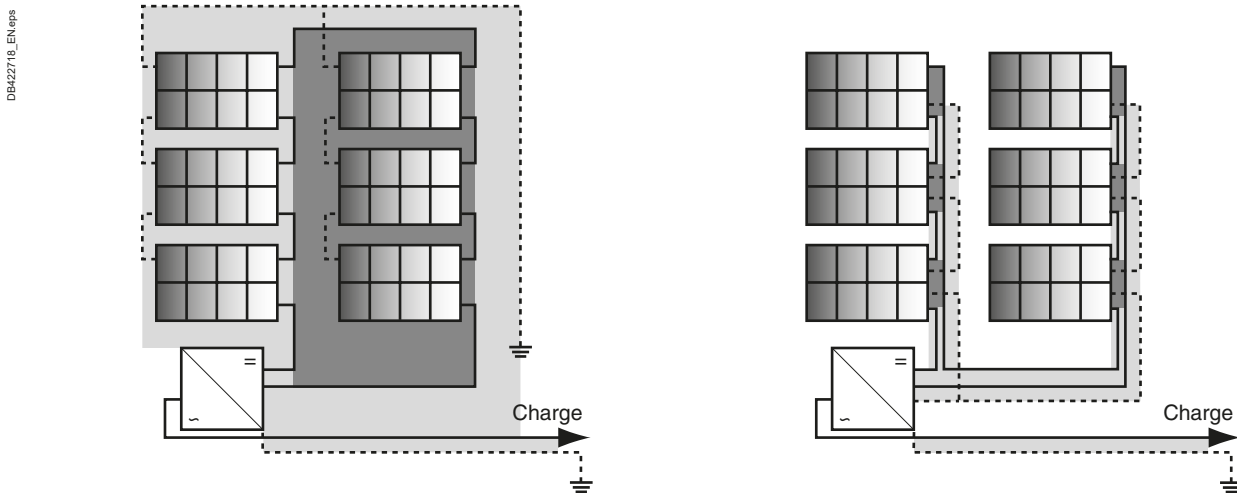


Fig. P16 Avoiding loops when cabling strings

4 PV installation architectures

4.2 PV System architectures

PV array with a single string of modules

This is the simplest configuration (see Fig. P17). It is used for small PV arrays with peak power of up to 3 kWp depending on the modules deployed. In most cases, it is used for residential PV operations.

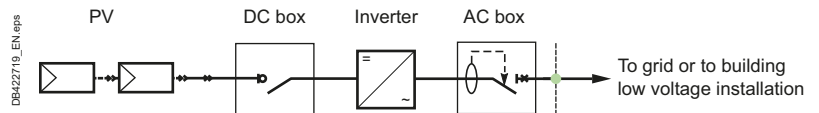


Fig. P17 Diagram showing a single-string photovoltaic array

Modules are connected in series, supplying direct current of between 200 and 500 VDC in this instance. Optimal efficiency is obtained from the inverter within this voltage range.

A single DC line is fed through to the inverter. The PV array can be isolated from the inverter by means of a load break switch near the inverter.

PV array with several module strings in parallel

This configuration (see Fig. P18), mainly deployed on buildings or in small PV power plants on the ground, is used for PV installations of up to thirty strings in parallel with power output of some 100 kWp.

The strings are paralleled in a PV string combiner box. This box includes the safety devices required for paralleling the strings and appliances used to measure the strings' current. A single DC cable connects these boxes to the inverter.

The PV array can be isolated from the inverter by means a load break switch near the inverter.

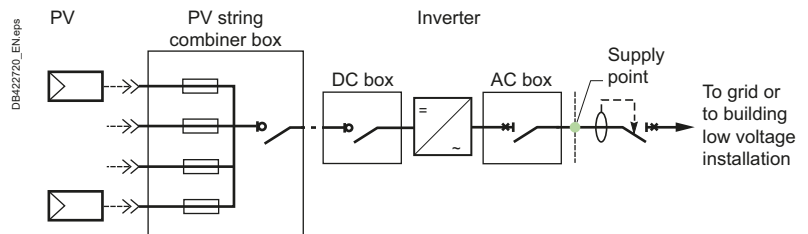


Fig. P18 Diagram showing a multi-string photovoltaic array with one inverter

4 PV installation architectures

As a variation on this diagram, several single-phase inverters can be installed in a three-phase arrangement (see Fig. P19).

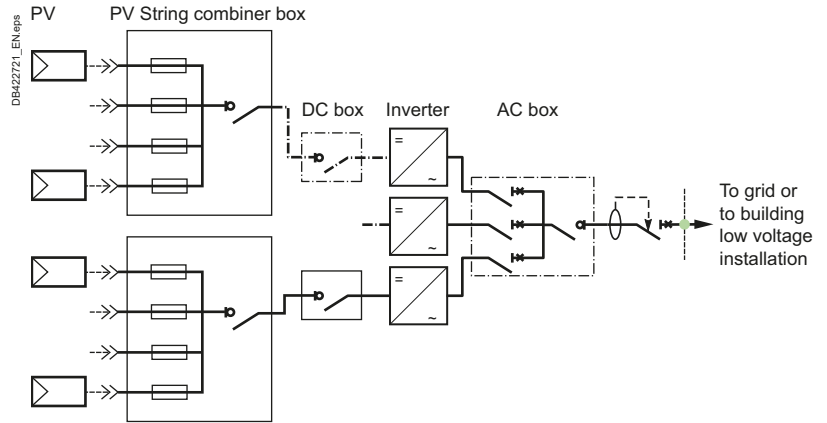


Fig. P19 Diagram showing a multi-string photovoltaic array with several single-phase inverters connected in a three-phase arrangement

PV array with several strings divided into several groups

When power levels exceed 50 or 100 kW, photovoltaic arrays are split into subgroups (see Fig. P20) to make it easier to connect the various components. Strings are paralleled on two levels.

- Strings in each subgroup are paralleled in subgroup PV string combiner boxes. These boxes are fitted with safety devices, the necessary measuring equipment and monitoring devices.

- The outputs of these boxes are paralleled in a PV array combiner box near the inverter. This box is also fitted with the required safety devices as well as the measuring and monitoring equipment necessary for paralleling the subgroups.

The array can be isolated from the inverter using a load block switch which may or may not be fitted in the PV array box.

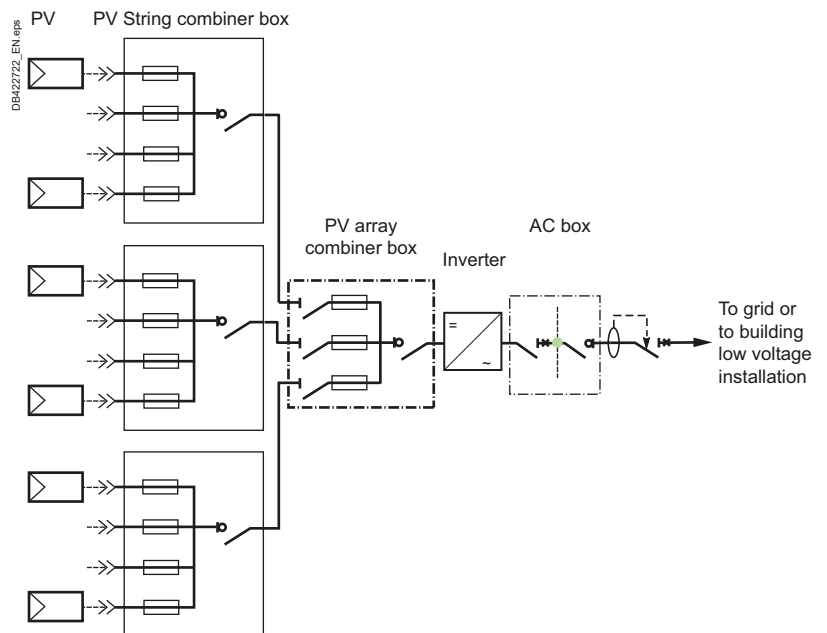


Fig. P20 Diagram showing a photovoltaic array consisting of several groups

P16

4 PV installation architectures

PV AC Module or "String inverter"

An alternate solution to DC system is to closely link the inverter to the PV module, in that case the PV module become an AC power source. This solution, called PV AC Module, or "String inverter" is comon for small installation but can be used also for larger system. In that case all the paralleling and wiring is done in AC. General rules for AC system apply.

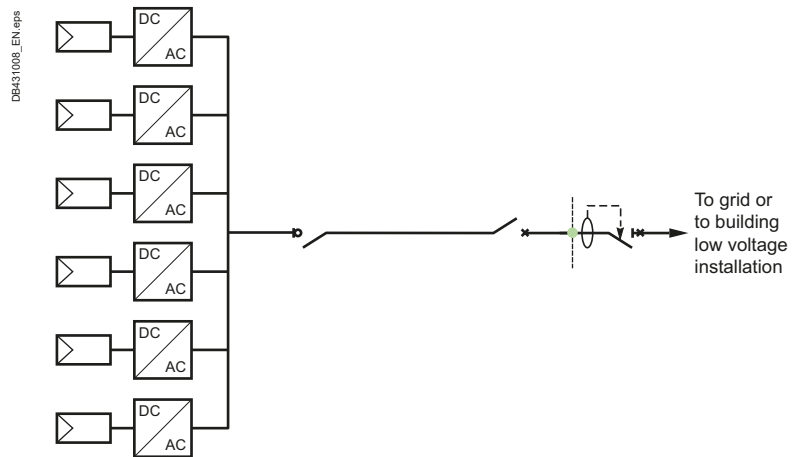


Fig. P21 Exemple of architecture based on "PV AC modules"

4.3 Sizing

Calculating a photovoltaic array

It is absolutely essential to take into account the location (geographic location, latitude, altitude, shade, etc.) and installation factors (direction faced, angle, etc.).

Firstly, the approximate power output may be calculated based on the available surface area:

$$10 \text{ m}^2 = 1 \text{ kWp}$$

$$7140 \text{ m}^2 (\text{=football ground}) = 700 \text{ kWp}$$

The PV array should always be arranged around the inverter. The calculations involved should compare the characteristics of the modules and those of the inverter with a view to identifying the optimal configuration.

■ String composition:

NB: Number of modules x Voc (at t° min) < inverter Vmax

The no load voltage of the string (Voc x number of modules in series) at the minimum temperature of the installation location must be lower than the inverter's maximum input voltage.

=> This must be strictly observed. Otherwise the inverter may be destroyed.

Apart from the aforementioned rule for preventing destruction of the inverter Number of modules x Voc (at t° min) < inverter Vmax – two other limits are observed:

□ Number of modules x Vmpp (at t° max) > inverter Vmin

The operating voltage (Vm x number of modules in series at all temperatures at the installation location) should fall within the inverter's MPPT voltage range. Otherwise, the inverter will stall and energy supply will cease.

□ Isc strings < inverter I max

The total Isc current for strings in parallel must be lower than the maximum input current for the inverter. Otherwise, the inverter limits the supply of energy delivered to the network.

4 PV installation architectures

Inverter specifications

■ In Europe, the power level of the inverter must be between 0.8 and 1 times the power of the array:

$$0.8 < P_{\text{inverter}} / P_{\text{array}} < 1$$

□ Below this (under $0.8 P_{\text{array}}$), the inverter limits power significantly. The energy sold to the network will thus be inferior to that which the panels are capable of supplying and therefore it will take longer to secure a return on investment.

□ Above this (over P_{array}), the inverter is too large for the power level of the array. Again, it will take longer to secure a return on investment.

■ Single-phase or three-phase

A decision should be made over these two options in consultation with the local energy distributor based on the devices available in manufacturers' product ranges, often within the following limits:

□ Inverter $P_n < 10 \text{ kW}$ => single phase inverter

□ $10 \text{ kW} < P_n < 100 \text{ kW}$ => either three-phase inverter(s) or single-phase inverters split between the three phases and neutral. The management of unbalances between phases needs to be checked in this instance.

□ $P_n > 100 \text{ kW}$ => three-phase inverter(s)

■ Configuration software

Manufacturers of inverters help design offices and installers to size strings for residential and service sector installations based on the equipment available by supplying sizing software.

4.4 Installation type

The installation type is a factor which should not be neglected since, in countries including France, the purchase price for power supplied is dependent on this. Along with shading, it should be taken into account when choosing a module.

There are three installation types – building integrated, partially integrated and ground-based:

■ Building Integrated PhotoVoltaic (BIPV)

This installation type fulfils a dual role (energy supply and roof waterproofing, shading, etc.).

■ Partially integrated

This is the simplest assembly to install and, most importantly, does not alter the water resistance of a roof. However, its major drawback is that, in France, operators cannot charge the highest rate for it. This installation type is most commonly used in Germany and Switzerland.

■ Ground-based

This installation type is used for power supply plants covering large areas (photovoltaic farms). Again, in France it is not eligible for the highest purchase price.

4 PV installation architectures

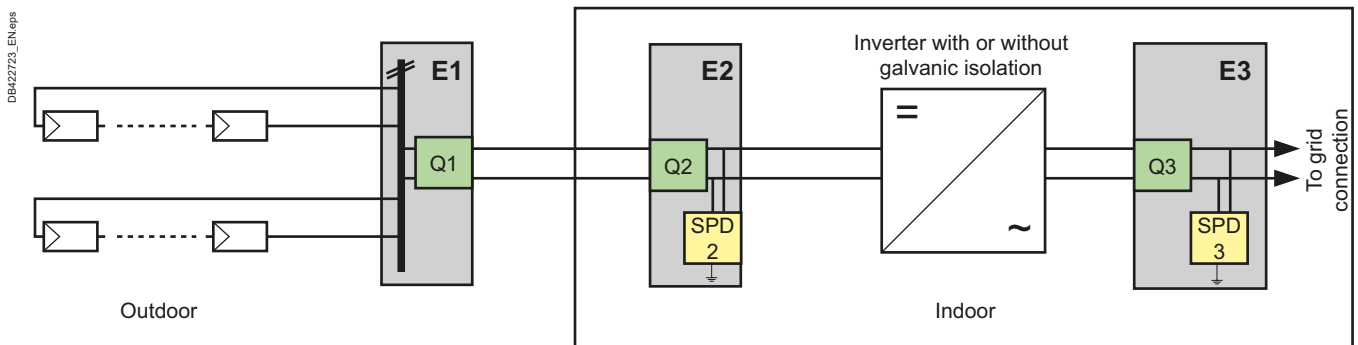
4.5 Electrical equipments selection

4.5.1 Grid connected PV system ≤ 10kW (Residential)

One single phase inverter

Typically, a 5kW grid-connected single-phase inverter. with UOC MAX ≤ 600V. One or two strings – Isctc < 25A, IAC < 32A. In this design there is no string protection.

A PV main switch is necessary. When the inverter is indoors, an additional remotecontrolled switch at the DC cable entry point is recommended for emergencies services.



Needs	String combiner box	PV main switch	Inverter	AC box (230V P/N)
Switchgears and control				
Isolation	<input checked="" type="checkbox"/>	<input checked="" type="checkbox"/> [d]	[a]	<input checked="" type="checkbox"/> [d]
Switching (Making & breaking rated current)	<input checked="" type="checkbox"/> DC21B	<input checked="" type="checkbox"/> [d] DC21B	[a]	<input checked="" type="checkbox"/> [d]
Control	<input checked="" type="checkbox"/> [b]	<input checked="" type="checkbox"/> [d]	[e]	<input checked="" type="checkbox"/> [d]
Over-current protection	[c]			<input checked="" type="checkbox"/> [f]
Protection against Insulation fault			[g]	[g] RCD type B or A SI
Surge protection		<input checked="" type="checkbox"/> type 2		<input checked="" type="checkbox"/> type 1 or 2
Enclosure	Outdoor Double insulation	Indoor Double insulation		Standard AC requirement + grid code requirement
Metering			Inverter relevant parameters	Energy

[a] PV array main switch could be included in the inverter. This solution makes inverter service or replacement more difficult.

[b] Remote switching for emergency services located as closely as possible to the PV modules or to the point of entry of DC cables in the building.

[c] No protection is required when the number of string does not exceed 2.

[d] Service and emergency switching.

[e] Inverter shall include a protection for anti-islanding (in accordance with VDE 0126 for example).

[f] Overload and short-circuit protection B curve recommended.

[g] If the inverter provides no galvanic separation a RCD protection is necessary on AC side. IEC 60364-712 specifies RCD type B.

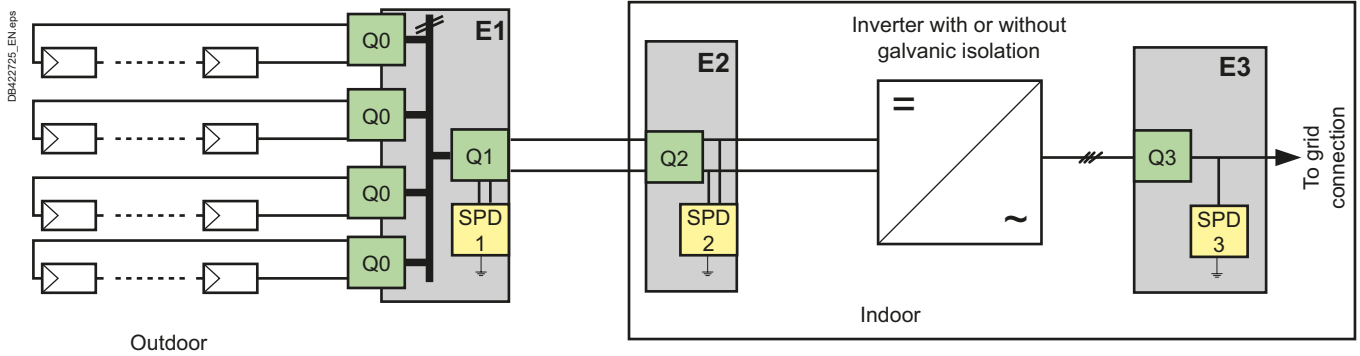
Some local regulations require RCD type A SI.

Fig. P22 Grid connected ≤ 10kW

4 PV installation architectures

One three phase inverter with one string combiner box

Typically, 30kW to 60kW grid-connected inverters. $U_{OC\ max}$ is generally higher than 600V (up to 1000V), I_{sc} does not exceed 200A, I_{AC} does not exceed 100A. This design has more than 2 strings. Reverse current protection is therefore necessary. A main PV switch is required. When an inverter is inside, additional remote-controlled switch at DC cable entry point is recommended for emergencies.



Needs	String combiner box	PV main switch	Inverter	AC box (230V P/N)
Switchgears and control				
Isolation	<input checked="" type="checkbox"/>	<input checked="" type="checkbox"/> [d]	[a]	<input checked="" type="checkbox"/> [d]
Switching (Making & breaking rated current)	<input checked="" type="checkbox"/> DC21B	<input checked="" type="checkbox"/> [d] DC21B	[a]	<input checked="" type="checkbox"/> [d]
Control	<input checked="" type="checkbox"/> [b]	<input checked="" type="checkbox"/> [d]	[e]	<input checked="" type="checkbox"/> [d]
Over-current protection	<input checked="" type="checkbox"/>	[c]		<input checked="" type="checkbox"/> [f]
Protection against Insulation fault			[h]	[h] RCD type B or A SI
Surge protection	[g]	<input checked="" type="checkbox"/> type 2		<input checked="" type="checkbox"/> type 1 or 2
Enclosure	Outdoor IP5x Double insulation	Indoor IP5x Double insulation		Standard AC requirement + grid code requirement
Metering				P,Q, PF, Energy

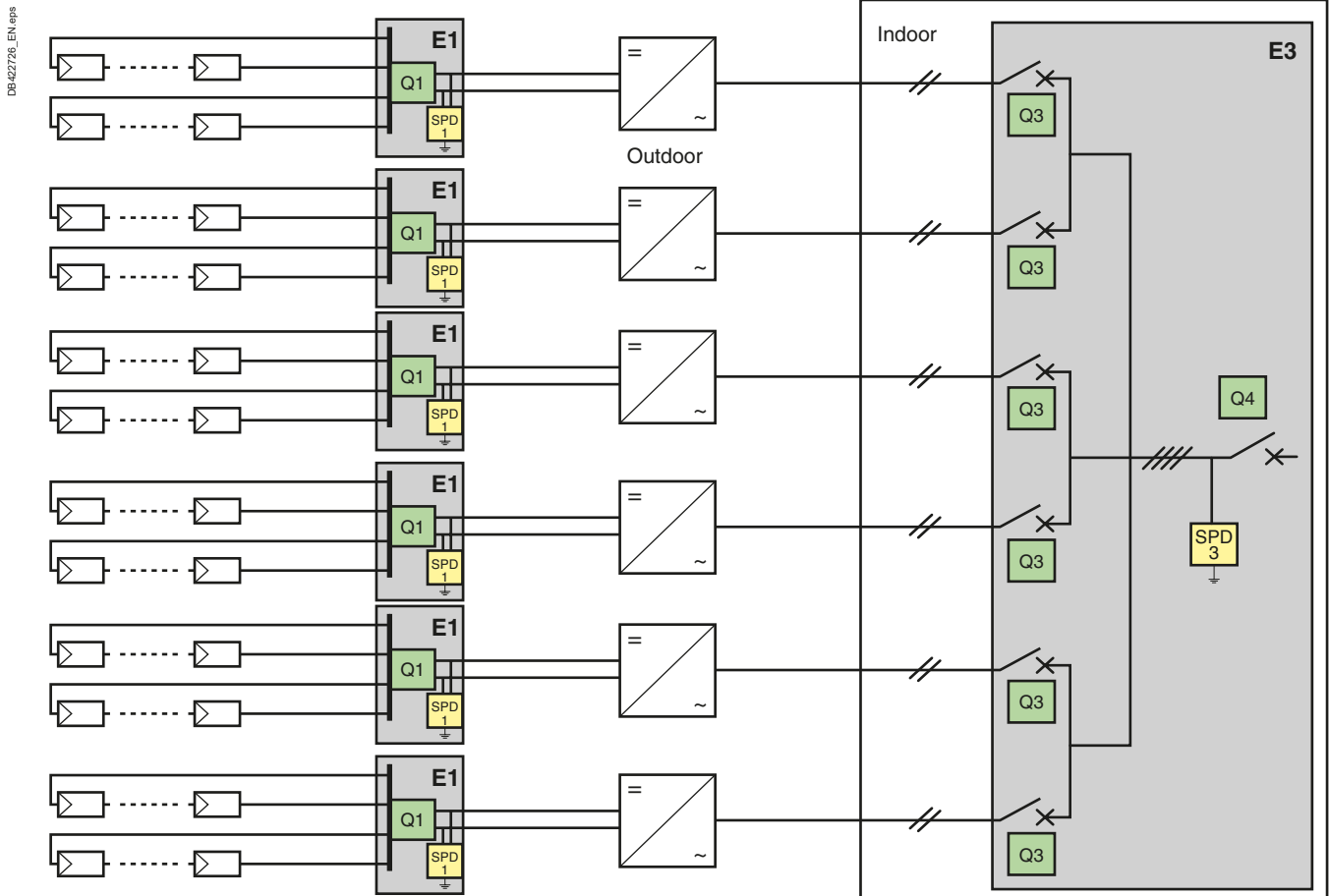
- [a] PV array main switch could be included in the inverter. This solution makes inverter service or replacement difficult.
- [b] Remote switching for emergency services located as closely as possible to the PV modules or to the point of entry of DC cables in the building. The main switch in array box can be equipped with tripping coil and motor mechanism for remote reclosing for that purpose.
- [c] No protection is required. The array cable shall be selected to withstand maximum current of the array.
- [d] Service and emergency switching.
- [e] Inverter shall include a protection for anti-islanding (in accordance with VDE 0126 for example).
- [f] Overload and short-circuit protection (B curve recommended).
- [g] If there is no SPD in the inverter or if the distance between String / Array junction box and inverter exceeds 10m a SPD is necessary in this box.
- [h] If the inverter provides no galvanic separation a RCD protection is necessary on AC side. IEC 60364-712 specifies RCD type B. Some local regulations require RCD type A SI.
 - If the inverter provides at least simple separation:
 - Without functional earthing: insulation monitoring is necessary
 - With functional earthing: the earthing shall be done with a DC circuit breaker or a fuse.

Fig. P23 10-100kW single MPPT inverter

4 PV installation architectures

Multi single phase inverters design

Typically, 6x5 to 20x5kW grid-connected inverters. The design used for residential building can be duplicated as often as necessary. In that case, the DC system is very simple and the AC system is very similar to usual AC systems.



Needs	PV array main switch	Inverter	AC box (400V)
Switchgears and control	See ≤10kW design		
Surge protection	<input checked="" type="checkbox"/> type 2		<input checked="" type="checkbox"/> type 1 or 2
Enclosure	Outdoor IP5x Double insulation		Standard AC requirement + grid code requirement
Metering		Energy	P,Q, PF, Energy, unbalance

Fig. P24 10-100kW multi single MPPT inverter

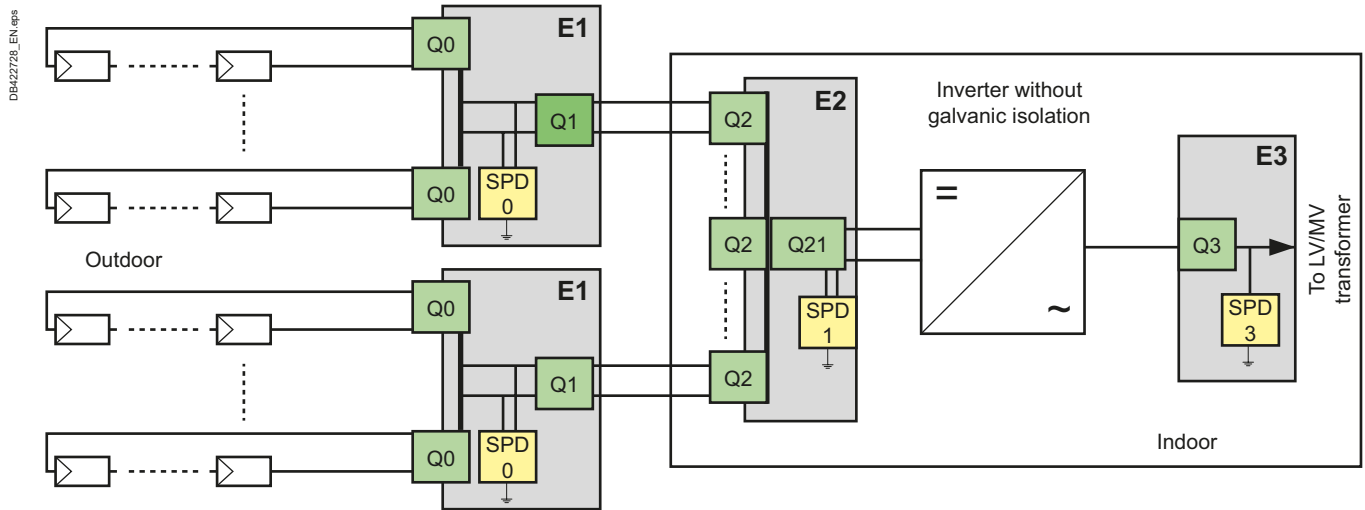
4 PV installation architectures

4.5.2 150 kW to 500 kW Grid connected PV system (Large building and farm)

Three phase inverter with more than two string-combiner boxes

Typically, 150 kW to 500 kW single inverter. This design is very similar to the three phase inverter with one string combiner box except that it has more arrays, which requires array cable protection.

$$I_{STC} \leq 400A, I_{AC} \leq 600A.$$



Needs	String	String combiner box	Array combiner box	Inverter	AC box 400V or other voltage (Transfoless inverter)
Switchgears and control					
Isolation	☑	☑	☑	☑ [a]	☑ [d]
Switching (Making & breaking rated current)		☑ DC22A	☑ DC22A	☑ [a]	☑ [d]
Control		☑ [b]		☑ [a] [e]	☑ [d]
Over-current protection	☑		☑ [c]		☑ [f]
Protection against Insulation fault				☑ [h]	☑ [h]
Surge protection		[g]	☑ type 2		☑ type 1 or 2
Enclosure		Outdoor IP5x Double insulation	Indoor Double insulation		Standard AC requirement + grid code requirement
Metering		Energy			P,Q, PF, Energy, Alarm, THD, individual harmonics

- [a] PV array main switch could be included in the inverter. This solution makes inverter service or replacement more difficult.
- [b] If switching for emergency services is required, the main switch in array box can be equipped with tripping coil and motor mechanism for remote reclosing.
- [c] Sub array cable protection is required as there are more than two sub arrays. To ensure fast trip of protections 6 to 8 arrays are recommended.
- [d] Service and emergency switching.
- [e] Inverter shall include a protection for anti-islanding (in accordance with VDE 0126 for example).
- [f] Overload and short-circuit protection.
- [g] If there is no SPD in the inverter or if the distance between DC box and inverter exceeds 10m a SPD is necessary in this box.
- [h] Galvanic insulation is provided by LV/MV transformer:
 - PV system without functional earthing: insulation monitoring is necessary.
 - PV system with functional earthing: the earthing shall be done with a DC circuit-breaker or a fuse.

Fig. P25 150-500 kW single MPPT inverter with N arrays > 2

4 PV installation architectures

4.6 Connection of PV system to the grid or to the private low voltage installation

4.6.1 Direct connection of PV system to the grid

When PV system is installed for "grid feeding", Utility that operates the grid will provide requirements for protection, disconnection, and metering function.

Each utility may have specific requirements according to local habits and grid specificity.

As a general rules the following functions are required :

- Energy meter (both direction)
- Disconnecting device (some countries require visual break)
- Over-current and earth fault protection according to earthing system
- Anti-islanding protection like VDE0126.

4.6.2 Connection of PV system to the private low voltage installation

See section 5 "PV architectures for self-consumption".

5 PV architectures for self-consumption

There are two main possibilities for connection and operation of PV systems installed on a building rooftop, car park, or integrated in the building structure – self-consumption and grid export.

In the export-to-grid operation, the PV installation is connected to the electrical distribution network and it does not interfere with the building electrical installation. Although physically linked, the PV system and the building installation are two independent and autonomous units.

In case of self-consumption, the PV system is connected to the building electrical installation where the PV production is used in priority to satisfy the electrical consumption needs of the local loads.

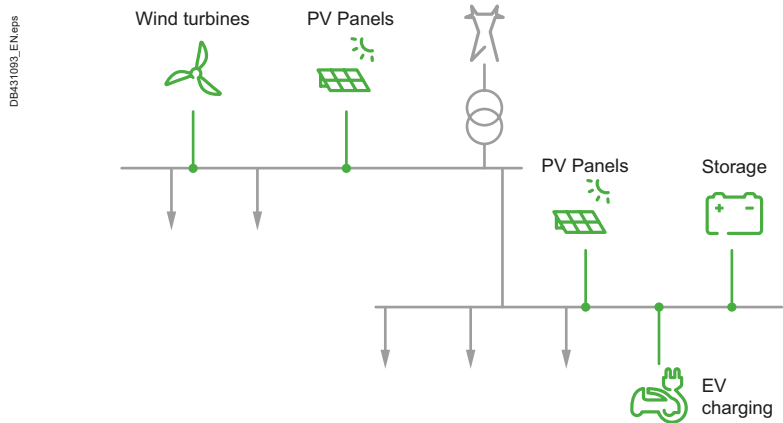


Fig. P26 Installation including PV (renewables) for self-consumption

As there is a physical connection between the two installations, the self-consumption of PV production comes with specific installation rules and architecture requirements.

Electrical installations with local PV generation for self-consumption could be designed to operate:

- **only grid-connected** - In case of blackout at the electrical network side, the electrical installation is no longer supplied by the local generation. Current PV systems used for self-consumption operate mainly in this mode.
- **grid-connected and islanded** – the electrical installation operates connected to the grid, but can also operate in an off-grid mode supplying the totality of the loads or part of them with the local energy sources. Today PV installations cannot assure the operation of the electrical installation in off-grid mode standalone, as the produced PV energy is volatile, predictable, but unplannable and with limited control capabilities. To assure an off-grid operation, PV installations must be associated to another major and stable source such as Storage or Generator. Also, the operation of the electrical installation in both grid-connected and island mode is much more complex and requires a dedicated control. This kind of operation is rare, especially in countries where the electrical grid is stable and blackouts are abnormal.

This section focuses on electrical installations with local PV production operating grid-connected, which is the main use of PV systems in the case of self-consumption. The specific requirements for installations with PV production for self-consumption are explained and guidelines for sizing and equipment selection are provided.

5.1 PV system connection to the electrical installation

The integration of PV system into the electrical installation can be done through a connection:

- to the main LV Switchboard
- to a distribution LV Switchboard
- upstream to the main LV switchboard
- to the MV system

The corresponding schemes, field of application, advantages and drawbacks for each of these possibilities are detailed hereafter.

5 PV architectures for self-consumption

5.1.1 Connection at the main low voltage switchboard

With this configuration, the PV Installation architecture can include:

- a single PV inverter, directly connected to the main LV switchboard
- a group of PV inverters. The inverters' outputs are gathered to a local generation switchboard and each in its turn feeds the main LV switchboard of the electrical installation – see Fig. P27. (Another possibility is to connect each inverter individually to the main LV switchboard, but this configuration is not recommended for cost, installation complexity and maintenance reasons)

The PV inverter power range used for self-consumption in commercial and industrial buildings being typically between 20kW and 60kW, it can be considered that for installed power up to 30kW a single inverter is used, and above this value a group of inverters is preferred.

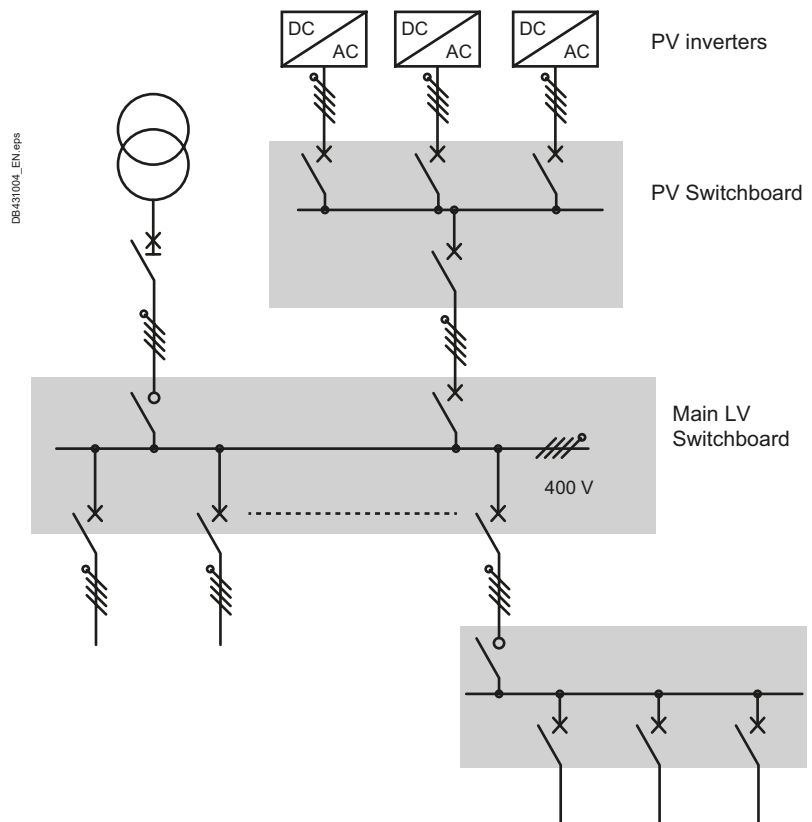


Fig. P27 PV installation connected to the main LV Switchboard

A configuration where the PV installation is connected to the main LV switchboard is used in the following cases:

- PV system is located near the main LV switchboard
 - PV production is used both for self-consumption and export to the grid of the excess PV energy
 - PV system is associated with other local energy sources, e.g., storage or CHP.
- A connection at the main LV switchboard allows all local production to be gathered in a single area, which facilitates the maintenance and the operation of the installation. It is the ideal configuration for new electrical installations, or existing ones when the main LV switchboard is easily accessible (e.g., one- or two-floor buildings)
- PV production capacity is between 10% to 100% of the building installed power. For smaller scale PV installations, a connection to a closer secondary switchboard can be preferred.
- For larger PV installations, a connection upstream to the LV switchboard can be more suitable for existing installations.

5 PV architectures for self-consumption

5.1.2 Connection to a distribution switchboard

The PV system is connected to the closest switchboard.

This configuration is preferred in the following situations:

- PV production does not exceed the consumption downstream to the switchboard it is connected to
- the PV inverters are far from the main LV switchboard.

This configuration is typically used in multi-floor buildings characterized by:

- A PV production at rooftop area significantly lower than the building energy consumption needs
- a main LV switchboard usually located at the ground floor (utility incomer through ground cables).

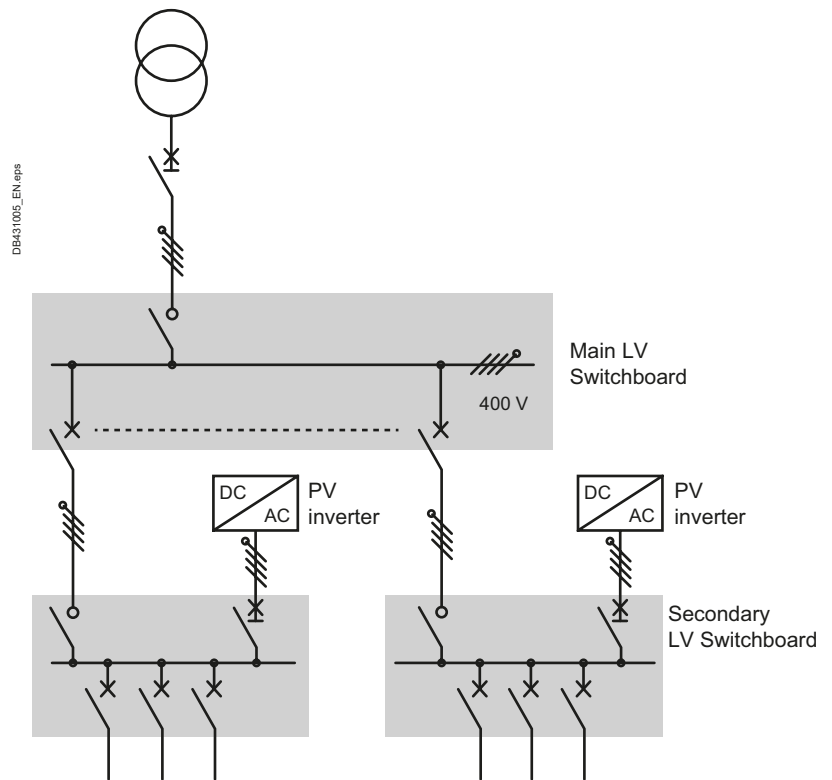


Fig. P28 PV installation connected to secondary LV switchboards

The connection to a secondary LV switchboard presents the following advantages:

- The cable length between the PV system and its connection point to the electrical installation is minimized
- The installation is easier and optimized.

Although, this configuration presents some limitations:

- More complex maintenance if the number of PV sources multiplies - When a feeder is under maintenance, all power sources potentially supplying the feeder must be isolated. When connecting PV installations to the closest switchboard, the number of connected power sources is potentially higher and much more dispersed, which makes the isolation more complex
- Limited upgradability – this configuration is much less evolutive than a connection to the main LV switchboard: an extension of the PV installation may require modifications in the existing building electrical installation (cables, switchboards and protections may need to be resized).

5 PV architectures for self-consumption

5.1.3 Connection upstream to the main low voltage switchboard

In this configuration, the PV installation is connected upstream to the main LV switchboard. A possible configuration is to connect all PV inverters and the utility incomer to a switchboard which feeds the main LV switchboard of the electrical installation. Another alternative, especially when the utility incomer and the local sources are not in proximity, is to connect a single output of the PV system to the utility incomer, before feeding the electrical installation.

This connection upstream to the main LV switchboard is used in existing buildings where the PV production capacity exceeds the load consumption for which the electrical installation is sized. In this case, a connection of the PV system to a secondary or main switchboard would overload the existing electrical infrastructure and will require its modification such as replacement of cables, switchboards and protection equipment. Coming as a better option, a connection upstream to the main switchboard does not require any modifications of the main LV switchboard or downstream to the installation.

The main advantage of this architecture is its capacity to integrate large-scale PV production without impact on the existing electrical installation infrastructure. It can be used both for self-consumption and export of PV production excess. A drawback can be the need for a dedicated, additional switchboard to gather all sources, which potentially increases the cost of the system.

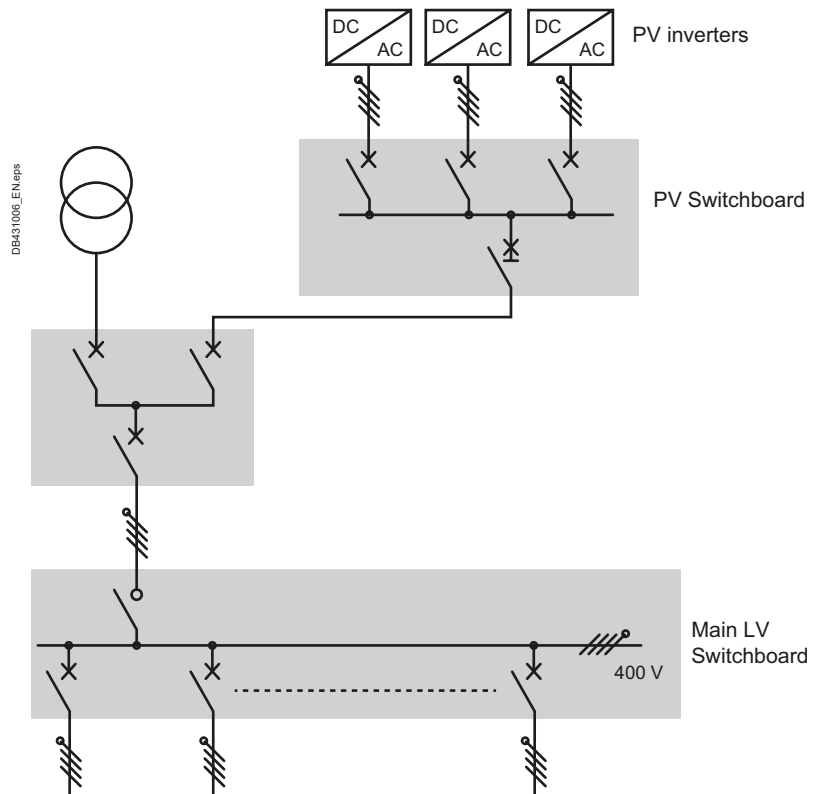


Fig. P29 PV installation connected upstream to the main LV switchboard

5 PV architectures for self-consumption

5.1.4 Connection to the MV system

A connection to the medium voltage side of the electrical installation is extremely rare, as the PV production and the electrical installation loads are in geographical proximity.

A medium voltage connection of the local PV production will require additional costs and will be less energy efficient, except if the PV production is far from the loads and with important production capacity.

5.2 Operation of electrical installation with local PV production

5.2.1 Normal operating conditions

Operating modes

In normal operating conditions, electrical installations with PV production for self-consumption are characterized by two operating modes:

- The electrical installation operates supplied by the grid only when there is no PV production (e.g., during the night)

The PV installation may be disconnected - as an option - through its protection device

- The electrical installation operates supplied both by the grid and by the PV installation when there is a PV production. The output waveform of the PV inverter(s) is synchronized with the grid voltage and frequency. This function is ensured by the PV inverter(s) embedded control.

The produced PV power goes to the loads, as the electricity takes in priority the path of least resistance. Consequently, there is no need of specific equipment redirecting the flow of electrons.

Management of excess PV production

In case where the PV production exceeds the instantaneous consumption needs of the electrical installation, one of the following management strategies can be adopted:

- Inject the excess power in the grid where it is consumed by other users. The injected power can be remunerated at the wholesale price of electricity, or at other tariff, or not given value at all depending on the agreement with the energy provider
- Limit the PV production - Some energy providers do not allow the injection of excess PV power in the grid, or authorize a restricted injection only
- Use storage
- Share the PV excess with a community, with a private electrical network if allowed by the local regulation

Generated disturbances

PV systems create some limited disturbances in the electrical installation, coming mainly from the operation of the PV inverters. Those are:

- Harmonics: as most electronic equipment, PV inverters generate harmonics. The harmonics emission is specified by the PV manufacturers, generally they are below 3%THDI.
- DC residual currents: In case of an earth fault on the DC part of the network, the feeding of a DC residual current at the AC side of the installation depends on the isolation between the DC and AC side of the PV system:
 - Galvanic isolation between DC and AC side of the PV installation guarantees that DC residual currents will not pass at the AC side.
 - When there is no galvanic isolation between the DC and the AC side, a DC residual current may be present at the AC side of the installation and must be eliminated, unless the PV inverter is designed to prevent, limit or avoid such situation.

When an electrical installation requires the installation of Residential Current Device (RCD) of the AC circuit, the type (AC, A or B) should be selected in function of the residual current that can be present. PV inverters manufacturer usually specify the injected by the PV inverters maximum DC residual current and the RCD type that should be used with this inverter.

5 PV architectures for self-consumption

5.2.2 Fault conditions

Utility supply loss

In installations operating grid-connected only, the PV inverters shut down automatically in the case of utility supply loss. They are not designed to provide back-up power during utility outages.

Fault inside the electrical installation

In the case of fault in the electrical installation, a high short-circuit current flows from the utility incomer to the fault location. The PV inverters also contribute to the fault providing their maximal current, which usually does not exceed two times the nominal PV inverter current (The maximal short-circuit current value is provided by the PV inverter manufacturer).

Electrical faults in installations with PV systems for self-consumption are localized and isolated by overcurrent protections, and specific protection functions or devices are not required.

The presence of PV inverters does not affect earth fault protection in the AC side of the installation.

PV inverters and DC side shall be protected against earth fault according to IEC 712.421.101.

5.3 Architecture and equipment requirements

When operating only grid-connected, PV systems used for self-consumption are simply connected to a switchboard of the electrical installation.

Loop configurations used to increase the energy availability in multi-source installations do not bring any benefit, as PV inverters stop operating in case of utility supply loss.

Automatic Transfer Operation

As described in the previous section, PV inverters operate in parallel with the grid. There is no transfer of operation from one source to another, thus Automatic Transfer Switch is not required for installations operating only grid-connected.

Earthing

As the PV system for self-consumption is part of the electrical installation, the earthing arrangement of the electrical installation applies also to the AC side of the PV inverter. If the PV inverter is with distributed neutral, this one is connected to the same earth reference as the transformer neutral. The creation of two earth references inside the same building is forbidden as currents may circulate between both earths.

The earth reference remains the same as far as the installation operates grid-connected.

Regarding the DC side of the PV inverter(s), there are two options:

- galvanic isolation between the DC and the AC side of the PV system: the earthing at the DC side does not depend on the earthing system of the AC electrical installation
- no galvanic isolation (most common case): the system earthing at the DC side must be compliant with the earthing of the AC electrical installation

Grid interconnection

In case of utility supply loss, installations with local generation are required to guarantee that they do not inject power into the grid for utility workers' safety.

For installations with PV production operating only grid-connected, this safety feature can be met by:

- the PV inverter (s) – most PV inverters integrate anti-islanding protection, which disconnects the PV inverter in case of power outage. The presence of this protection and its standard compliance is provided by the PV manufacturer
- a dedicated protection device installed at local sources feeders or at the utility incomer of the electrical installation.

5 PV architectures for self-consumption

Reverse power protection

Reverse power protection for PV inverters is not required as they are unidirectional devices and do not pass reverse current.

Reverse power protection may be required in the case of the presence of other local sources, such as diesel generators, where the flow of the current back to the generator may cause its failure.

Reverse power protection is usually not required to prevent the power injection into the grid in normal operating conditions, this function is assured through control of local sources.

5.4 Guidelines for sizing

Installations with PV production for self-consumption, even operating only grid-connected, present specific requirements on load flow calculation, placement and selection of the protection devices, and sizing of equipment.

Load flow and short-circuit currents

Installations with PV production for self-consumption are characterized by at least two operating modes (supplied by the grid, and supplied by the grid and the PV sources). The load flow and the short-circuit currents flow should be evaluated for each operating mode, and the electrical installation components and equipment should be sized accordingly, taking the worst-case constraints.

If storage is present in the electrical installation, it should be taken into account in the load flow and short-circuit currents calculation twice – once as a load (when charging) and once as a source (discharge).

Switchboard sizing

In single source installations, switchboards are sized in function of the maximal current drawn by the downstream load.

When a switchboard is fed by two or more sources, it should be sized in function of the maximal current that can transit through it, which can be:

- the current drawn by the load
- the current delivered by the local sources

Cable sizing

Cables' current ampacity must be higher than the maximal expected current, which should be evaluated for each operating configuration of the electrical installation.

Transformer sizing

In single source installations, transformers are sized in function of the installed load power.

In installations with PV production for self-consumption where the injection of PV production to the grid is possible, the transformer should be sized in function of the installed local sources power capacity.

5 PV architectures for self-consumption

Circuit breaker location

When a single inverter is connected to a switchboard of the electrical installation, a circuit breaker should be installed downstream to the cable connecting the PV inverter to the switchboard to isolate electrical faults or overloads occurring on the PV feeder.

When several PV inverters are regrouped to a switchboard before they interface with the electrical installation, it is recommended to install protection devices at both ends of the connection between the two switchboards:

- the role of the downstream breaker (CB2) is to isolate faults on the connection between the PV system and the building's electrical installation (in case of fault at C2, a high short-circuit current will flow on the path from the grid to the fault location. A tripping of CB2 will isolate the fault allowing the electrical installation to continue to operate supplied by the grid). Selectivity between CB1 and CB2 should be assured. Otherwise, a fault in the PV installation may trip the main breaker and interrupt the supply from the grid.
- the role of the upstream circuit breaker (CB3) is to isolate electrical faults on the PV switchboard, the selectivity between the downstream and the upstream breaker on the PV feeder should be met.

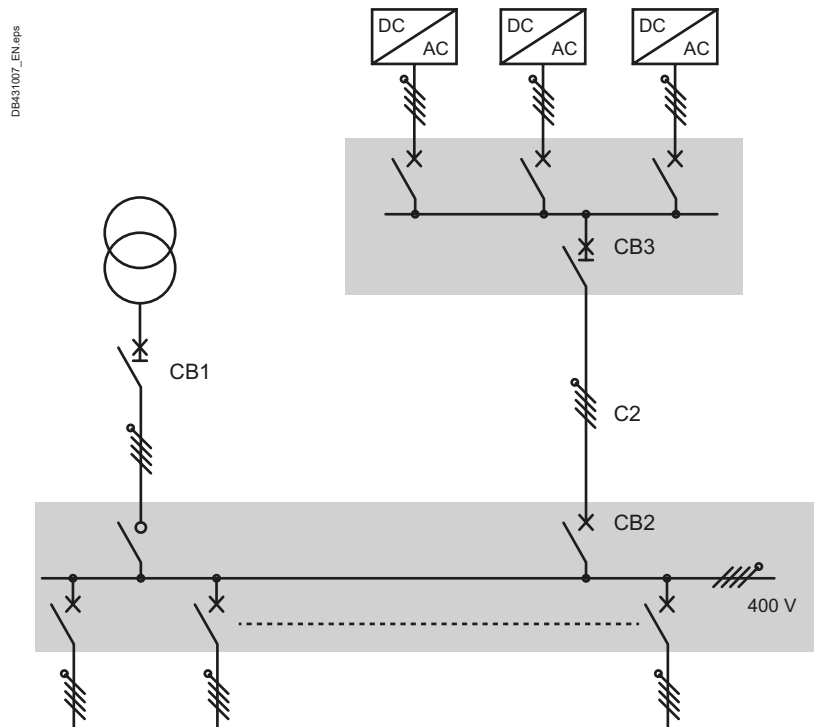


Fig. P30 Circuit breaker location

6 Monitoring

Whatever the size and use of a PV installation, the main purpose of a monitoring system is to follow the PV-produced energy, assess PV system performance, detect drifts or malfunctions, and notify about all faults immediately. Monitoring architectures and requirements are presented in this section.

6.1 PV installations for commercial and industrial buildings

PV system monitoring

In PV installations for grid export, the monitoring system provides:

- Measurement of the produced PV energy and calculation of its economic benefit on a daily and monthly basis
- Performance assessment of the PV system (detecting a decrease in the performance ratio and identifying potential causes, e.g., temperature, dirt or dust accumulation on the PV panel surface, mismatch and wiring losses, inverter status and operation)

The monitoring architecture is based on a data-logger, mostly equipped with a RS232/485 serial port to communicate with the inverters, using Modbus or a proprietary protocol. Data acquisition is based on a low-speed polling rate, every 10 minutes on average. Data may be stored locally in the data-logger for a short period of time, or pushed to an external server which store can data for years. The data-logger can also be equipped with auxiliary inputs, such as analogue inputs to monitor temperature irradiance sensors, digital input to monitor the status of an equipment, and/or pulse input to connect with an energy meter. Once the data are collected locally, the system sends output data and alerts as soon as they are generated to a remote monitoring system, where cloud-based applications, analytics, or services can be provided in addition.

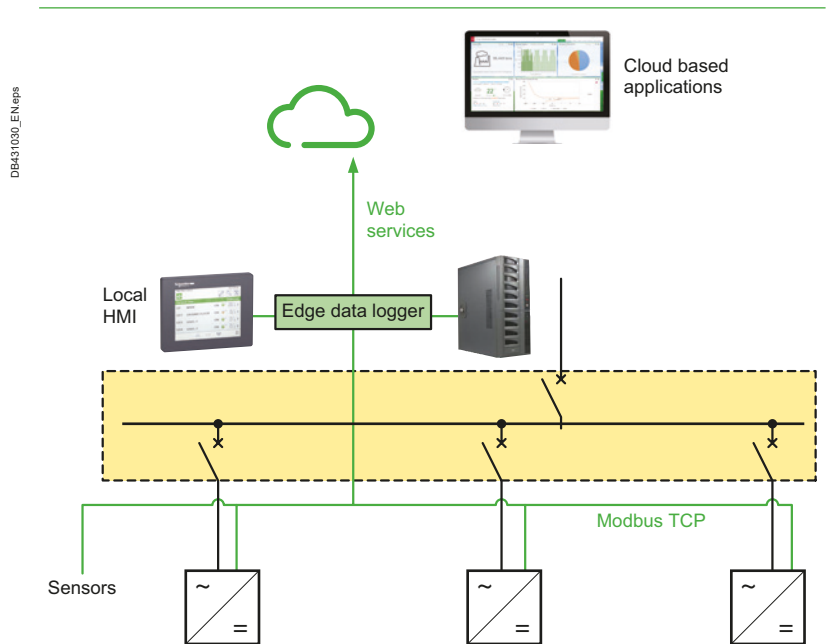


Fig. P31 Monitoring system for commercial PV installations

P32

6 Monitoring

Requirements for self-consumption

In the case of self-consumption, the produced PV energy is consumed by the building loads. The PV production excess (if any) is generally injected into the grid. To understand how the energy is used and how it can be optimized, Key Performance Indicators should be followed, such as:

- % use of PV production (self-consumption vs grid export)
- Self-consumption ratio
- Self-production ratio
- Trend analysis of PV production versus building consumption

The monitoring system should consolidate data from both PV production and building consumption. The monitoring system can be a building management or dedicated power management system, integrating PV production monitoring.

6.2 Utility scale power plants

Systems for utility-scale power plant, from 500 kWp upwards, are able to monitor the complete installation, from the string input to the point of connection to the grid.

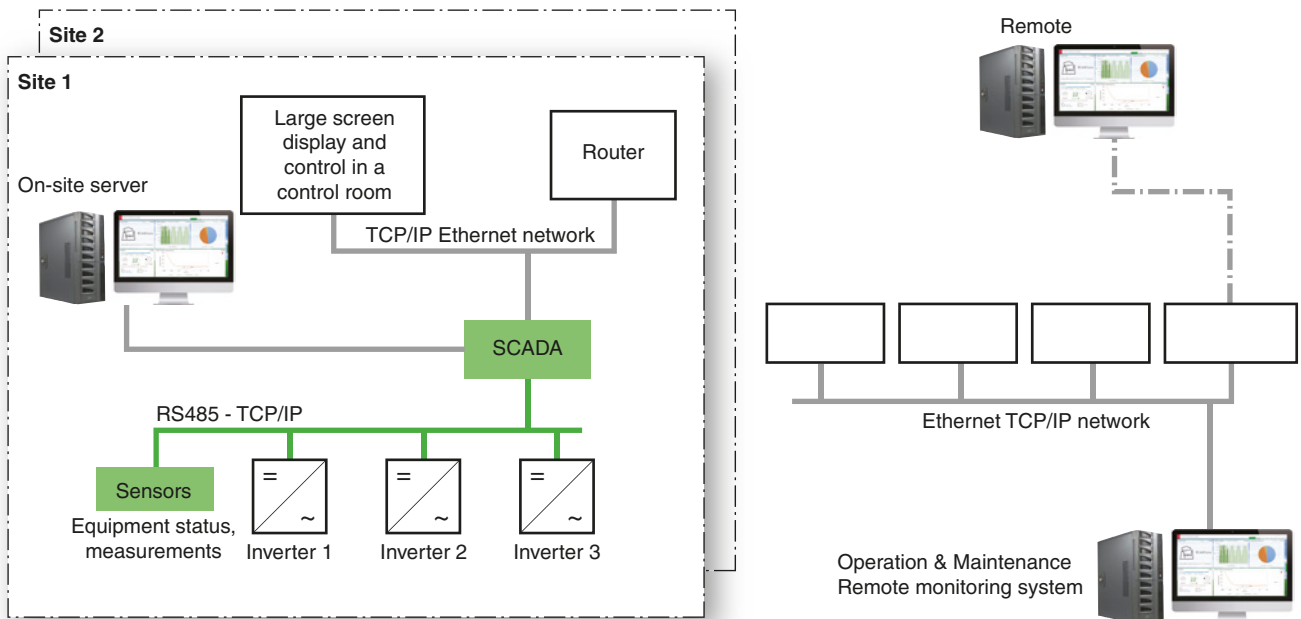
These systems are based on a SCADA (Supervision Control And Data Acquisition) system, which enables multi-site monitoring, DC and AC measurements, remote control of motorized equipment, smart alarming, report generation, performance indication, and other capabilities such as in-depth analysis.

These systems also include other equipment to run the site more efficiently, such as a weather station (temperature, wind and rain gauges), irradiance sensors, a plant controller communicating with the grid operator, to adapt the production of the site to the grid variation (voltage, power factor) – and specific meters such as revenue grade meters, close the point of connection

These SCADA systems can be local and/or remote, with redundancy capabilities and high performance data processing.

This type of installation is mostly served by a service contract for operations and maintenance and, in many cases, with performance objectives, which can include production, performance ratio, or availability.

D0942732_EN_0918



P33

Fig. P32 Example of a system for remote monitoring used in utility-scale power plants

Residential premises and other special locations

1	Residential and similar premises	Q2
	1.1 The power network.....	Q2
	1.2 Distribution boards components	Q2
	1.3 Protection of people	Q5
	1.4 Circuits	Q8
	1.5 Protection against overvoltages and lightning	Q8
	1.6 Periodic control of residential electrical installations.....	Q9
	1.7 Requirements and recommendations per type of room - Kitchen	Q10
	1.8 Requirements and recommendations per type of room – Living room.....	Q11
2	Bathrooms and showers	Q12
	2.1 Classification of zones	Q12
	2.2 Requirements prescribed for each zone	Q14
	2.3 Equipotential bonding.....	Q15
3	Requirements applicable to special installations and locations	Q16

1 Residential and similar premises

Electrical installations for residential premises need a high standard of safety and reliability

The international standard reference for electrical installation in buildings is the IEC 60364 series "Low-voltage electrical installations", and its European equivalent, the HD 60364. But these standards are general, applicable to all types of premises, and do not provide simplified and ready-to-use rules for residential premises.

Some of the standards from part 7 of the IEC 60364 address residential premises, such as the IEC 60364-7-701 "Requirements for special installations or locations – Locations containing a bath or shower", which provides mandatory additional safety measures for bathrooms (see section 2).

In practice, most countries have national regulations or standards governing the rules to be strictly observed in the design and realization of electrical installations for residential and similar premises. But these national standards are not harmonized internationally, and may range from very basic requirements to advanced requirements for safety and comfort.

Some of these national regulations and standards also include elements which are not covered or required by the IEC 60364 series:

- additional requirements for safety, like protection against fire risks with smoke detectors, or with the mandatory installation of AFDD (Arc Fault Detection Devices) in bedrooms ...
- requirements for (minimum) comfort, like minimum equipment per type of rooms (socket outlets ...)

Finally, additional requirements are needed to cover new "usages", like Electric Vehicle charging, photovoltaic installations ...

Therefore, the content of this section is an overview of the main requirements or recommendations for residential premises, from an international point of view, based on some advanced local standards from countries like France, Italy, Germany, Spain ...

Always refer to your local regulations and standards for the mandatory requirements applicable for residential or similar premises.

1.1 The power network

The vast majority of power distribution utilities connect the low voltage neutral point of their MV/LV distribution transformers to earth.

The protection of persons against electric shock therefore depends, in such case, on the principle discussed in chapter F. The measures required depend on whether the TT, TN or IT earthing system is adopted.

For **fault protection**, RCDs are essential for TT and IT earthed installations (see chapter F). For TN installations, high speed overcurrent devices (circuit breakers) or RCDs may provide **fault protection** of the electrical circuits. **Nevertheless**, to extend the protection to flexible leads beyond the fixed socket outlets and to ensure protection against fires of electrical origin **high sensitivity** RCDs shall be installed. AFDDs (Arc Fault Detection Devices) are also recommended (mandatory in some countries) to extend even more the protection against fire risks (see chapter F §9.3).

1.2 Distribution boards components

(see Fig. Q1, Fig. Q2, Fig. Q3)

Distribution boards (generally only one in residential premises) usually include the meter(s) and in some cases (notably where the supply utilities impose a TT earthing system and/or tariff conditions which limit the maximum permitted current consumption) an incoming supply differential circuit-breaker which includes an overcurrent trip. This circuit-breaker is freely accessible to the consumer.

The power distribution utility connects the LV neutral point of its MV/LV distribution transformer to earth. All LV installations must be protected by RCDs. All exposed conductive parts must be bonded together and connected to the earth.

Electrical equipment used in residential premises are commonly certified by third party ensuring conformity with the relevant standards. In this case, equipment shows the certification Mark of the certification body such as VDE, NF, AENOR, IMQ or others. Mark of conformity is a voluntary manufacturer process and implies periodic verifications of the Quality of the products by the third party laboratory. In EU zone CE marking is a mandatory self-declaration for free trade done by the manufacturer/importer.

Q - Residential premises and other special locations

1 Residential and similar premises

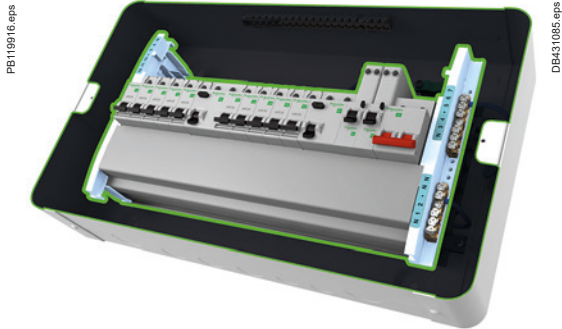


Fig. Q1 Example of typical UK residential distribution board

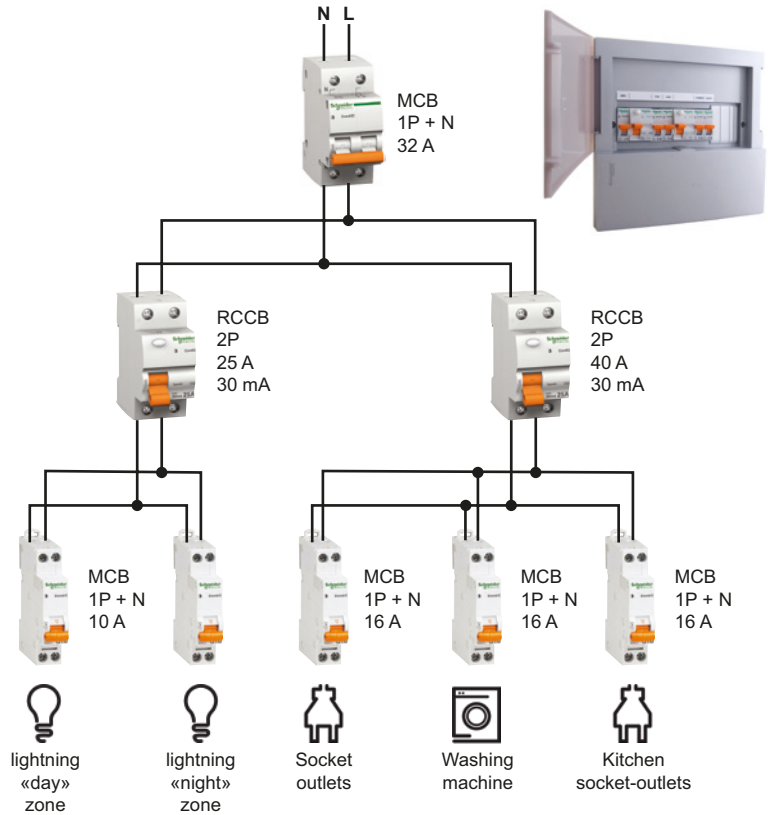


Fig. Q2 Example of Italian residential installation (> 125 m², basic level)

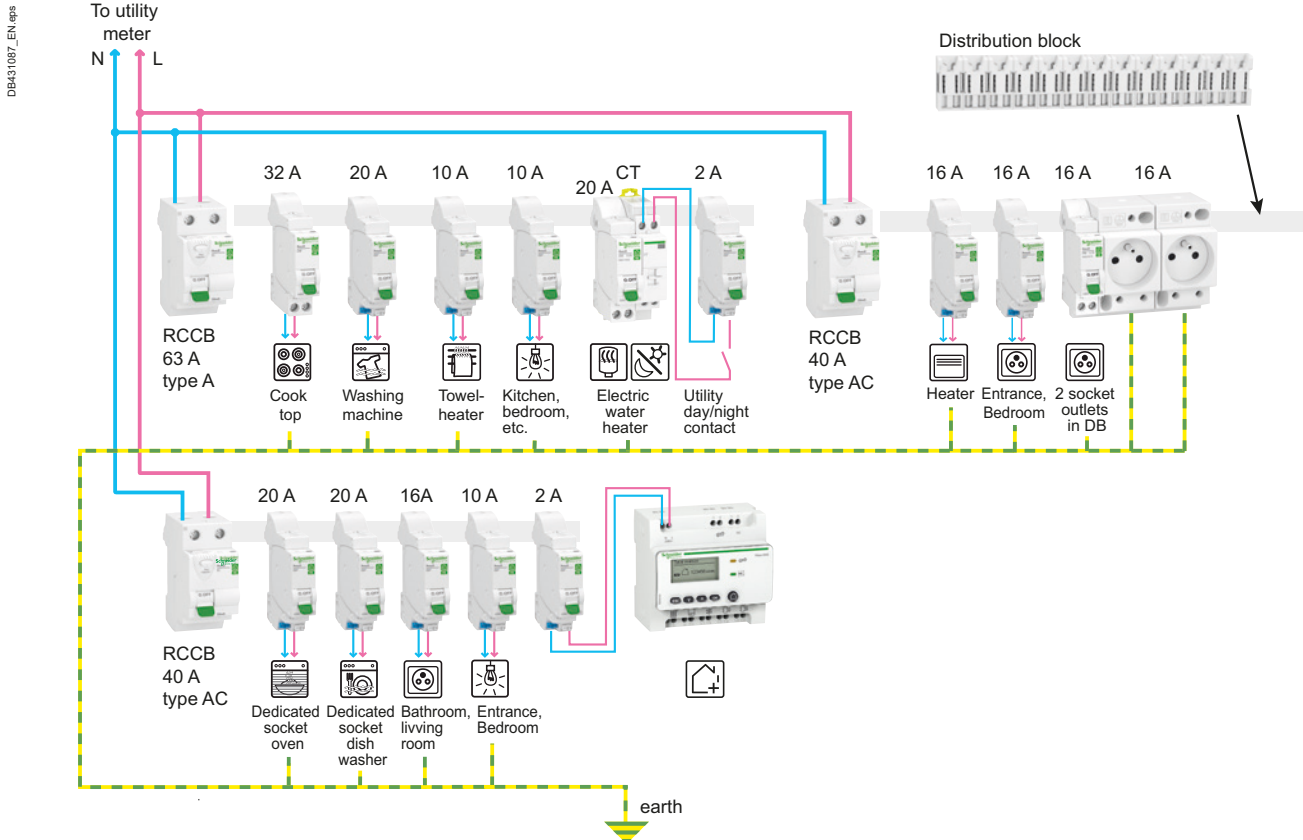


Fig. Q3 Example of French residential installation (3 rooms with electric heater)

1 Residential and similar premises

On installations which are in a TN earthing system, the supply utilities usually protect the installation simply by means of sealed fuse cut-outs immediately upstream of the meter(s) (see Fig. Q4). The user has no access to these fuses.

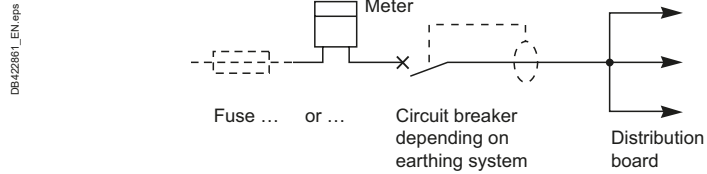


Fig. Q4 Components of a control and distribution board

The incoming supply circuit breaker or main switch (see Fig. Q5)

The consumer is allowed to operate this circuit breaker or switch if necessary (e.g. to reclose it if the circuit breaker has tripped due to current consumption exceeded the authorized limit, to open it in case of emergency, or for isolation purposes in case of maintenance in the distribution board).

For TT systems, the rated residual current of the incoming circuit-breaker shall be adapted to the maximum earth impedance:

- For example, if the earth impedance is not more than 100 Ohms, the rated residual current of the main RCBO shall not exceed 500 mA: $I_{dn} = 50 \text{ V} / 100 \text{ Ohms} = 500 \text{ mA}$
- In some countries, the rated residual current of the incoming circuit-breaker is 300mA. In this case, the earth electrode resistance shall be less than $R = 50 \text{ V} / 300 \text{ mA} = 166 \text{ Ohms}$
- In practice, the earth electrode resistance of a new installation shall be less than $80 \Omega (R/2)$.



[a] France (CB)



[b] UK (switch-disconnector)

Fig. Q5 Examples of incoming-supply circuit breakers or switch from different countries



Fig. Q6 Example of control and distribution board (France)

The control and distribution board (consumer unit) (see Fig. Q6)

This board comprises:

- A control panel for mounting (where appropriate) the incoming supply circuit breaker and other control auxiliaries, as required
- A distribution panel for housing the MCBs or fuse units, etc.
- Installation accessories like DIN rails for mounting MCBs, fuses bases, connection accessories like comb busbars to simplify interconnection of devices, accessories for fixing conductors, neutral busbar and earthing bar, and so on
- Service cable ducts or conduits, surface mounted or in cable chases embedded in the wall

Note: to facilitate future modifications to the installation, it is recommended to keep all relevant documents (photos, diagrams, characteristics, etc.) in a suitable location close to the distribution board.

The board should be installed at a height such that the operating handles, indicating dials (of meters) etc., are accessible to users. Heights commonly recommended are between 1 metre (or less in some countries) and 1.80 metres from the floor (1.30 metres in situations where handicapped or elderly people are concerned).

1 Residential and similar premises

Surge protective devices

The installation of surge protective devices (SPD) at the service position of a LV installation is strongly recommended for installations which include sensitive (e.g. electronic) equipment, which is very common nowadays.

These devices must automatically disconnect themselves from the installation in case of failure or be protected by a MCB. See §1.5.

If, in a TT scheme, the value of 80Ω for the resistance of the electrode cannot be met, then 30 mA RCDs must be installed to take over the function of the earth leakage protection of the incoming supply circuit breaker

Resistance value of the earth electrode

In the case where the resistance to earth exceeds 80Ω , one or several 30 mA RCDs should be used in place of the earth leakage protection of the incoming supply circuit breaker.

Where utility power supply systems and consumers' installations form a TT system, the governing standards impose the use of RCDs to ensure the protection of people

1.3 Protection of people

On TT systems, the protection of persons is ensured by the following measures:

- Protection against indirect contact hazards by RCDs (see Fig. Q7) of medium sensitivity (300 mA) at the origin of the installation (incorporated in the incoming supply circuit breaker or, on the incoming feed to the distribution board). This measure is associated with a consumer installed earth electrode to which must be connected the protective earth conductor (PE) from the exposed conductive parts of all class I insulated appliances and equipment, as well as those from the earthing contact of all socket outlets

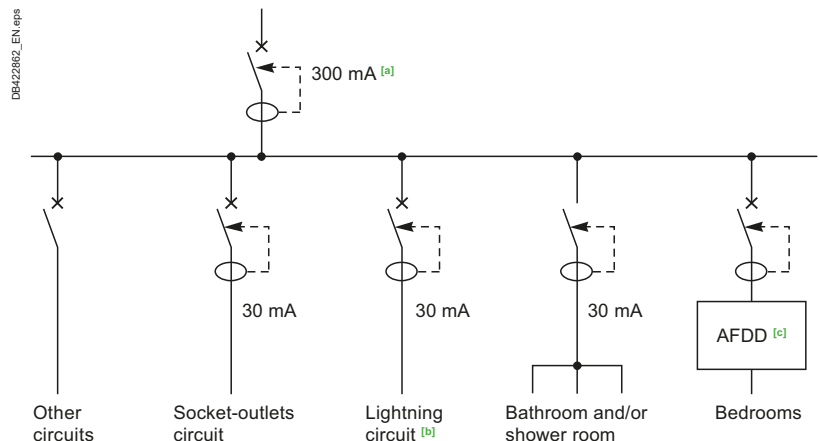
- When the CB at the origin of an installation has no RCD protection, the protection of persons shall be ensured by double or reinforced insulation on all circuits upstream of the first RCDs. In the case where the distribution board is metallic, care shall be taken that all live parts are double insulated (supplementary clearances or insulation, use of covers, etc.) and wiring reliably fixed

In TN systems, fault protection is ensured by the following measures:

- Fault Protection is ensured by circuit breaker at the origin of the installation.
- This measure is associated with a consumer installed earth electrode to which must be connected the protective earth conductor (PE) from the exposed conductive parts of all class I insulated appliances and equipment.

For all earthing systems:

- mandatory protection by 30 mA high sensitivity RCDs of socket outlet circuits, and circuits feeding bathroom. And recently, the IEC 60364 also requires the use of 30 mA RCD for lighting circuits



[a] RCD required for Fault Protection in TT systems. In TN system a circuit-breaker is used.

[b] Recent evolution of IEC 60364 = 30mA RCDs mandatory for lighting circuits

[c] see chapter F §9.3 related to Arc Fault Detection Devices

Fig. Q7 Requirements of IEC 60364 for protection of people

1 Residential and similar premises

Incoming supply circuit breaker with instantaneous differential relay

In this case:

- An insulation fault to earth could result in a shutdown of the entire installation
- Where a surge protective device is installed, its operation (i.e. discharging a voltage surge to earth) could appear to an RCD as an earth fault, with a consequent shutdown of the installation

Recommendation of suitable Schneider Electric components

- Incoming supply circuit breaker with 300 mA differential and
- High sensitivity 30 mA RCD (for example differential circuit breaker 1P+N type resi9) on the circuits supplying socket outlets
- High sensitivity 30 mA RCD (for example differential load switch type ID'cllc) on circuits to bathrooms, shower rooms, laundry rooms, etc. (lighting, heating, socket outlets)

Incoming supply circuit breaker with type S time delayed differential relay

This type of CB affords protection against fault to earth, but by virtue of a short time delay, provides a measure of selectivity with downstream instantaneous RCDs. Tripping of the incoming supply CB and its consequences (on deep freezers, for example) is thereby made less probable in the event of lightning, or other causes of voltage surges. The discharge of voltage surge current to earth, through the surge arrester, will leave the type S circuit breaker unaffected.

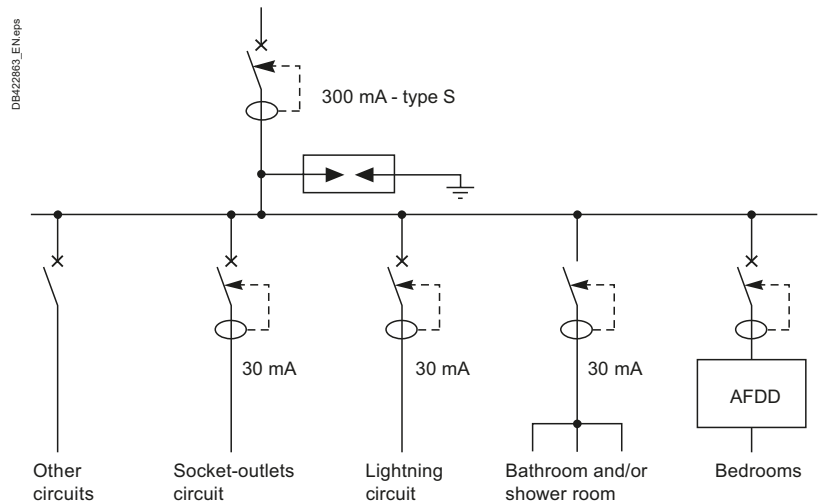


Fig. Q8 Installation with incoming-supply circuit breaker having short time delay differential protection, type S

1 Residential and similar premises

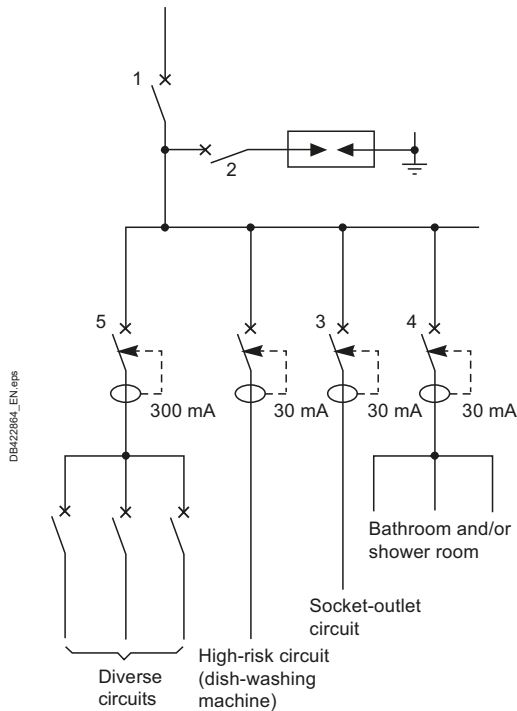


Fig. Q9 Installation with incoming-supply circuit breaker having no differential protection

Incoming supply circuit breaker without differential protection

In this case the protection of persons must be ensured by:

- Class II level of insulation up to the downstream terminals of the RCDs
- All outgoing circuits from the distribution board must be protected by 30 mA or 300 mA RCDs according to the type of circuit concerned as discussed in chapter F.

Where a voltage surge arrester is installed upstream of the distribution board (to protect sensitive electronic equipment such as computers, TV sets, internet access boxes etc.) it is imperative that the device automatically disconnects itself from the installation following a rare (but always possible) failure. Some devices employ replaceable fusing elements; the recommended method however as shown in **Fig. Q9**, is to use a circuit breaker.

Recommendation of suitable Schneider Electric components

Fig. Q9 refers:

1. Incoming-supply circuit breaker without differential protection
2. Automatic disconnection device (if a lightning arrester is installed)
3. 30 mA RCD (for example differential circuit breaker 1P + N type Declic Vigi) on each circuit supplying one or more socket-outlets
4. 30 mA RCD (for example differential load switch type ID'clic) on circuits to bathrooms and shower rooms (lighting, heating and socket-outlets) or a 30 mA differential circuit breaker per circuit
5. 300 mA RCD (for example differential load switch on all the other circuits.

1 Residential and similar premises

The proper separation of circuits provides service continuity and eases rapid location of fault

DB-422865_EN_0pp8

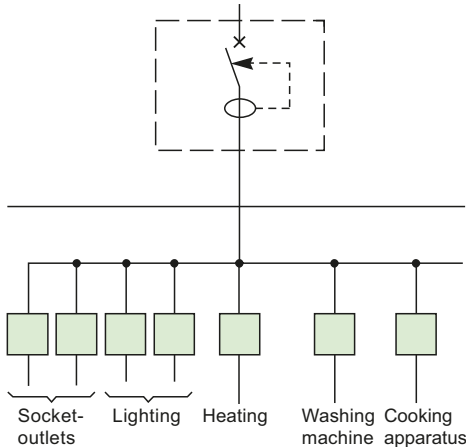


Fig. Q10 Circuit division according to application

Implementation of a protective conductor (PE) for all circuits is required by IEC and most of national installation rules

1.4 Circuits

Subdivision

National standards commonly recommend the subdivision of circuits according to the number of utilization categories in the installation concerned (see Fig. Q10):

- At least one lighting circuit, each circuit supplying several rooms for a maximum surface of 50 m²,
- At least one socket-outlets circuit rated 16 A (rating according to National socket-outlet system), each circuit supplying a reasonable number of socket-outlets in series, taking into account the wiring cross-section area used (1.5 mm² or 2.5 mm²), the wiring lengths (voltage drops) and the temperature rise effects on each connection, according to the foreseeable applications used.
- One dedicated circuit for each "high load" appliance such as washing machine, dish-washer, cooker etc. Water heater and fixed heater units shall be connected by terminals (not socket-outlet neither connector).

Recommended number of socket-outlets and fixed lighting points

An example of recommended number of socket-outlets and fixed lighting points, according to the applications and the locations in dwellings, are given in Fig. Q11

Room type	Minimum number of fixed lighting points	Minimum number of socket-outlets
Living room	1	5
Bedroom, lounge, living and dining room	1	3
Kitchen	2	4 [a]
Bathroom	2	1
Entrance, hall, stairs	1	1
Cellar, storage space	1	1
Laundry room	1	2

[a] Above bench, in addition to those for specialized circuits.

Fig. Q11 Recommended minimum number of lighting and power points in residential premises

Protective conductors

IEC 60364 and most national standards require implementation of protective conductor for each circuit. This practice is mandatory where equipment provided for earthing (Class I) may be connected or installed, and shall be seen as the general case for all circuits including circuits supplying socket outlets. The protective conductors must connect the earthing contact in each socket-outlet to the main earthing terminal at the origin of the installation. Furthermore, in some countries, 16 A (13 A in UK) household socket-outlets must be provided with shutters, at least in rooms where children are often present, and in places where water is present.

Cross-section area of conductors

The cross-section area of conductors and the rated current of the associated protective device depend on the load(s) connected to the circuit, the ambient temperature, the material of construction where the cables are located, the type of installation, and the influence of neighboring circuits (refer to chapter G). Moreover, the conductors for the phase, the neutral and the protective conductors of a given circuit must have the same cross section area up to 32 A circuits.

1.5 Protection against overvoltages and lightning

The choice of Surge Protective Devices as well as their installation rules are described in chapter J.

The three following main rules must be respected in particular:

1. It is imperative that the three lengths of cable used for the installation of the surge arrester each be less than 50 cm i.e.:
 - the live conductors connected to the isolating switch
 - from the isolating switch to the surge protective device
 - from the surge protective device to the main distribution board (MDB) earth bar (not to be confused with the main protective-earth (PE) conductor or the main earth terminal for the installation). The MDB earth bar must obviously be located in the same cabinet as the surge protective device.

1 Residential and similar premises

2. It is necessary to use an isolating switch of a type recommended by the manufacturer of the surge protective device.
3. In the interest of a good continuity of supply it is recommended that the circuit breaker be of the time-delayed or selective type.

1.6 Periodic control of residential electrical installations

IEC installation standard recommends a frequency for periodic verification of dwelling of 10 years. IEC 60364-6: 2016 § 6.5.2

IEC 60364 recommends periodic verification of electrical installations

Electrical risks in new residential buildings are covered by installation and product standards. However, for existing buildings the safety levels in older buildings are often far below current standards.

IEC 60364-6 recommends periodic verification of electrical installations in dwellings. For example, mandatory safety audits are an efficient means to verify if the electrical installation is in safe conditions, and to inform the owner of the safety level of its home.

Why periodic verifications are necessary in dwellings

Existing electrical installations may be dangerous because of:

- Installations complying to standards dating back to the year of construction, and the technical requirements of standards changing over the ensuing years
- Aging of the electrical installation itself, including loose connections, aged insulation material, broken parts such as shutters in socket outlets for example, or flying terminal block for luminaires
- Change of usage of electricity due to changes in the numbers of inhabitants, and the electrical installation was modified by the persons living in the dwelling, and usually not by a qualified electrician

Typical types of dangerous situations may be such as:

- Absence of protective earthing conductor (PE) in dwelling
- Absence of protection against electric shocks at the origin of the installation
- Overcurrent protective devices not adapted to the cross-section of the conductors
- Absence of high-sensitivity residual current device (RCD, 30 mA) in bathrooms and for circuits supplying socket outlet up to 32 A and in dwelling circuits for lighting
- Damaged socket outlets or socket outlet without PE conductor
- Incorrect use of extension cords leading to overloaded socket outlets
- Damaged and outdated electrical equipment

What are the minimum points to check?

Item	Safety check	Rationale	Examples
1	Presence of a main incoming switching device	To disconnect the whole installation in case of emergency	Disconnecting switch, circuit breaker, residual current device with overcurrent protection
2	Presence of overcurrent protective devices adapted to cross-section of conductors in a switchboard	To ensure overload and short-circuit protection	Circuit breakers or fuses
3	Presence of protective earthing conductor and protective device for automatic disconnection of supply in accordance with earth impedance	To ensure protection against electric shocks in case of a fault	Yellow-green PE conductor, circuit breaker (TN-system), medium-sensitivity residual current device (TT system)
4	Presence of high sensitivity residual current devices for socket outlet circuits and outdoor equipment	To ensure additional protection against electric shocks	High sensitivity residual current device (e.g. 30 mA RCD)
5	Specific protective measures for locations containing bath or shower: PE, high sensitivity RCD, volume rules	Specific measures for protection against electric shocks in humid locations	Yellow-green conductor, 30 mA residual current device
6	No risk of direct contact due to old, damaged, overheated electric accessories or conductors	Old electric accessories (switches, socket outlets, terminal blocks) or conductors not mechanically protected create risks of electric shocks	Visual inspection of socket outlets, switches, conductors, switchboard

Fig. Q12 Example of recommend points to check during periodic verification of electrical installations in dwellings

1 Residential and similar premises

1.7 Requirements and recommendations per type of room - Kitchen

DB431090_EN.eps

Safe connection of Luminaires

Fixed luminaires shall preferably be connected by plug and socket (DCL: Device for the connection of luminaires) to the fixed installation. DCL outlet will be connected to the fixed wiring, while the luminaire has the plug. This will make the luminaire easy to replace in a safe way.



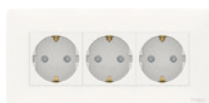
Dedicated circuits

Cooking tops, stoves, and microwave ovens can be high loads. In most cases the connection used for high consuming devices are dedicated plug and socket-outlets, or fixed connected by terminals, according to the national standards or regulations.



Number of Socket outlets

Socket-outlets for kitchen appliances must be located spread in the kitchen where the appliances are used, e.g. coffee machine, toaster, kettle (water boiler) etc. As this is a practical need for all users, some countries have national requirements for quantities and locations.



Charging station

There are USB chargers available for the fixed installations. The benefit will be to have one charger in a dedicated location for all your devices, e.g. phone, tablet, etc.

The kitchen could be a convenient location for a USB charger in your installation.



Fig. Q13 Example of recommendation - typical circuits and wiring devices to install in a kitchen (refer to your local standards for actual mandatory requirements)

1 Residential and similar premises

1.8 Requirements and recommendations per type of room – Living room

DB641091_EN.eps

Working corner

In a modern home, a location to work is in many situations a part of the living room. Typical devices to be powered are screen(s), computer, router, printer, etc.

This must be considered and prepared by additional fixed socket outlets, avoiding the use of cord extension sets and giving priority to permanent connection.



Dimmers

To get an atmosphere for different occasions dimming of light is an important factor.

The recommendation is to install dimmers split into zones where light shall be controlled independently.



Movement / presence detector

For light controls it can be very convenient to use movement or presence detectors.

In particular in halls or staircases.



Audio Video corner

Socket outlets must be spread out on the principles that a living room can be furnished in many ways and even refurbished.

One fixed location is anyway the Audio Video corner where there are need for several devices, e.g. TV set, decoder, recorder etc. This must be considered and prepared by additional fixed socket outlets, avoiding the use of cord extension sets and give priority to permanent connection.



Energy efficiency

In a home, the living room is often the biggest room, and potentially the important room when considering energy efficiency.

Electronic thermostats control the temperature, impacting the energy consumption day/night and summer/winter. Installation must be planned according to the specific need



Q11

Fig. Q14 Example of recommendation - typical circuits and wiring devices to install in a living room (refer to your local standards for actual mandatory requirements)

2 Bathrooms and showers

Bathrooms and shower rooms are areas of high risk, because of the very low resistance of the human body when wet or immersed in water.

Precaution to be taken are therefore correspondingly rigorous, and the regulations are more severe than those for most other locations.

The relevant international standard is IEC 60364-7-701, applicable to the electrical installations in locations containing a fixed bath (bath tub) or shower and to the surrounding zones. Refer to country specific standards (or deviations from the IEC requirements) whenever they exist.

Precautions to observe are based on three aspects:

- The definition of zones, numbered 0, 1 and 2 in which the placement (or exclusion) of any electrical device is strictly limited or forbidden and, where permitted, the electrical and mechanical protection is prescribed
- The strict adherence to the requirements prescribed for each zone, as tabled in §2.3.
- The establishment of an equipotential bond between all exposed and extraneous metal parts in the zones concerned.

2.1 Classification of zones

Sub-clause 701.30 of IEC 60364-7-701 defines the zones 0, 1 and 2, illustrated by the following figures for most common examples. Refer to the standard for a more complete view.

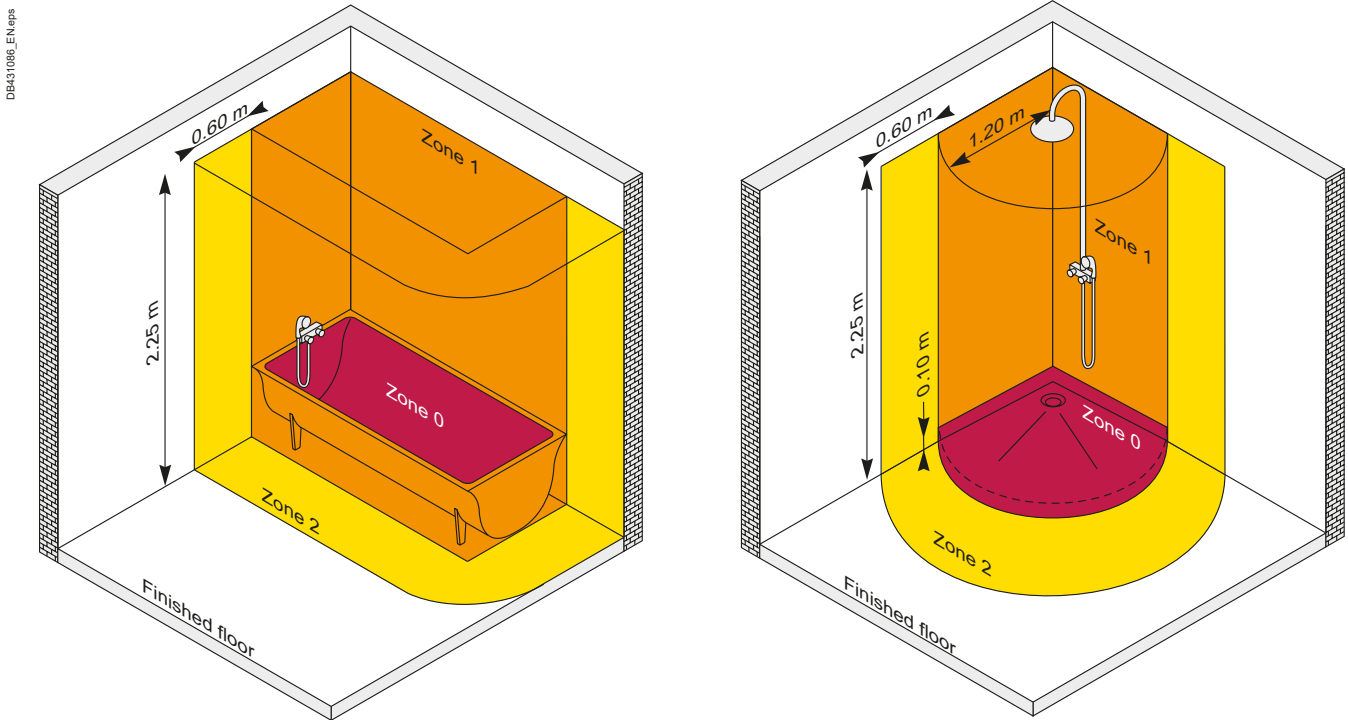


Fig. Q15 Definiton of zones 0, 1 and 2 (global view)

2 Bathrooms and showers

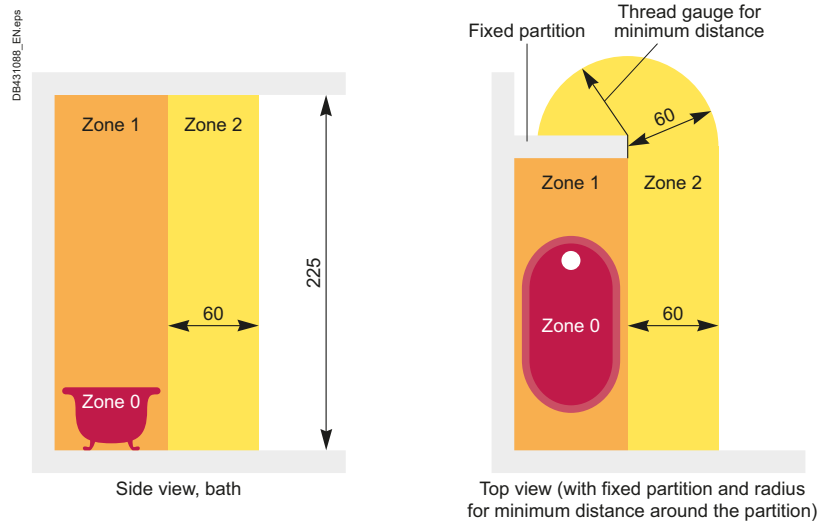


Fig. Q16 Definition of zones 0, 1, and 2 – Bath tub complementary examples

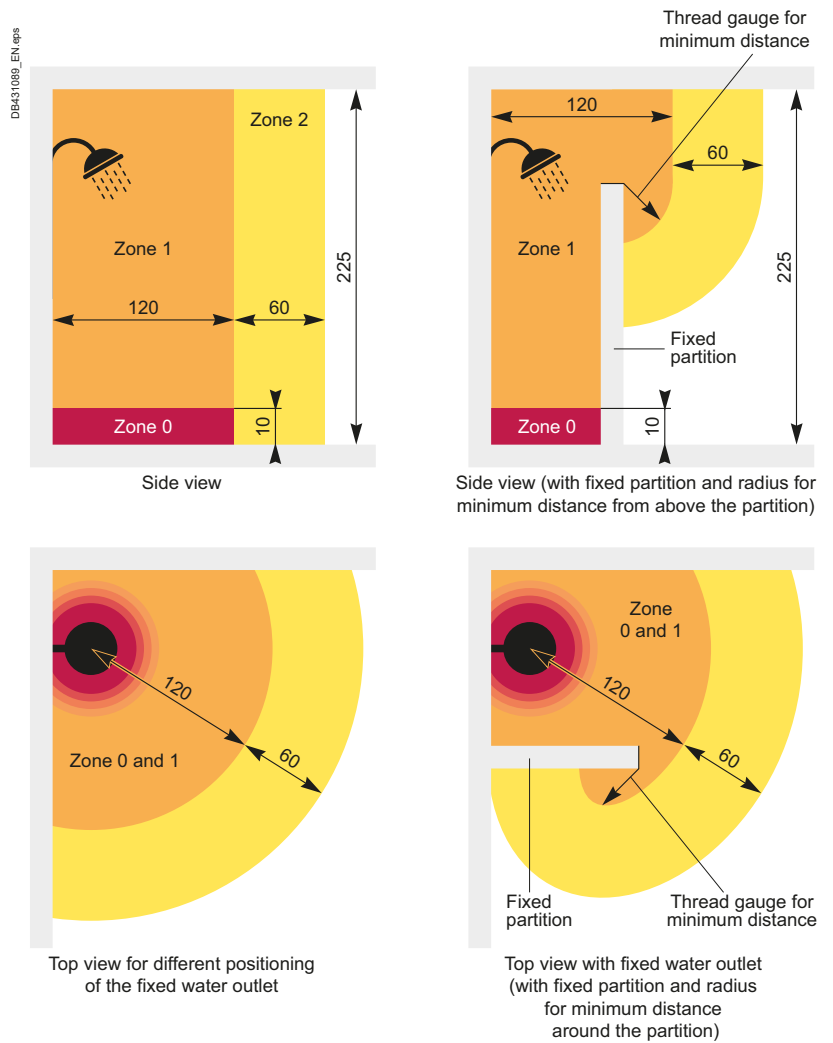


Fig. Q17 Definition of zones 0, 1, and 2 - shower without basin complementary examples

Q13

2 Bathrooms and showers

2.2 Requirements prescribed for each zone

The IEC 60364-7-701 provides the specific requirements for the different zones defined in §2.1, applicable to the equipments, circuits ...

It is an international standard that has been achieved as a compromise between countries, considering their existing national standards and regulations, thus it includes a significant number of notes providing country specific requirements. It is thus difficult to share a simplified view of these requirements.

Therefore, what you see below is an overview of the requirements for each zone, based on French standard (NFC 15-100). Always refer to your national standards for the applicable local requirements.

Zone	Equipment IP required
Zone 0	IPX7
Zone 1	IPX4 ^[a]
Zone 2	IPX4

[a] IPX5 for showers with horizontal water jets

Fig. Q18 Equipment IP required for each zone

Type of equipment	Zone 0	Zone 1	Zone 2	Outside zones 0..2
Equipment IP required	IPX7	IPX4 ^[a]	IPX4	standard
Wiring system (cables and trunking)	-	only to supply circuits authorized in this zone	only to supply circuits authorized in this zone	OK
Junction boxes	-	-	-	OK
Socket-outlet	-	-	-	OK ^[c]
Shaver supply-unit (20 to 50 VA)	-	-	OK	OK
Switch	-	SELV ≤ 12 Vac ^[b]	SELV ≤ 12 Vac ^[b]	OK
Separation transformer for SELV circuit	-	-	-	OK
Luminaire	SELV ≤ 12 Vac ^[b]	SELV ≤ 12 Vac ^[b]	Class II <input type="checkbox"/>	Class I
Heater, towel rail	-	-	Class II <input type="checkbox"/>	Class I
Water heater (water reserve)	-	horizontal and as high as possible	direct cable connexion, no connexion box	OK
Washing machine, tumble dryer	-	-	-	OK

Cells with a grey background indicate that such equipment is forbidden in this zone.

[a] IPX5 for showers with horizontal water jets

[b] Separation transformer of the circuit shall be installed outside zones 0..2

[c] Outside zones 0..2, all circuits shall be protected by 30mA RCDs (or separation transformer, SELV or PELV)

Fig. Q19 Overview of the specific requirements for bathrooms and shower rooms (based on French NFC 15-100 standard) - refer to your local standard for actual and complete requirements

2 Bathrooms and showers

2.3 Equipotential bonding (see Fig. Q20)

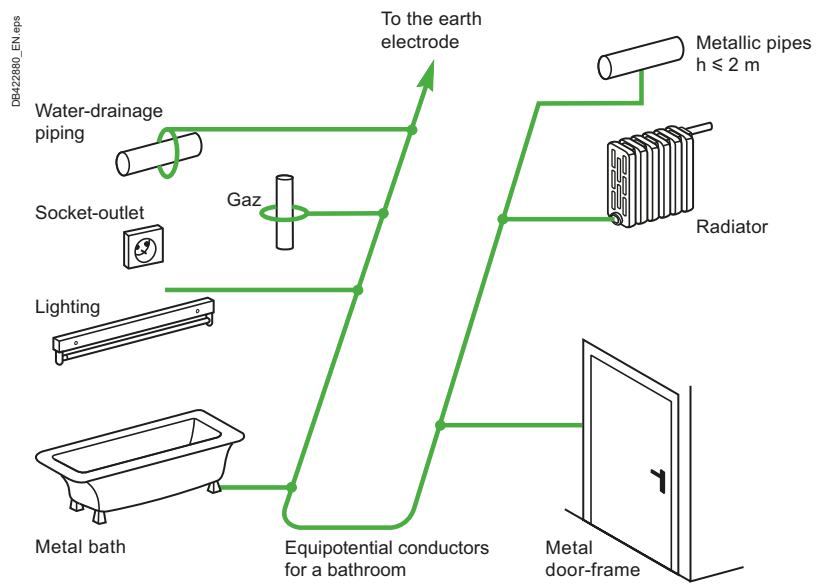


Fig. Q20 Supplementary equipotential bonding in a bathroom

3 Requirements applicable to special installations and locations

The IEC 60364-7-7xx standards (part 7 of the IEC 60364) are detailing the mandatory “Requirements for special installations or locations”. These requirements supplement, modify or replace certain of the general requirements of the other parts of IEC 60364.

These parts shall be applied in conjunction with the other parts of IEC 60364: where a Clause is not mentioned in the Part 7, that means the Clause shall be applied as defined in the general part of IEC 60364.

Below is a list of the existing standards in this part 7:

IEC 60364-7-701	Locations containing a bath or shower
IEC 60364-7-702	Swimming pools and fountains
IEC 60364-7-703	Rooms and cabins containing sauna heaters
IEC 60364-7-704	Construction and demolition site installations
IEC 60364-7-705	Agricultural and horticultural premises
IEC 60364-7-706	Conducting locations with restricted movement
IEC 60364-7-708	Caravan parks, camping parks and similar locations
IEC 60364-7-709	Marinas and similar locations
IEC 60364-7-710	Medical locations
IEC 60364-7-711	Exhibitions, shows and stands
IEC 60364-7-712	Solar photovoltaic (PV) power supply systems
IEC 60364-7-713	Furniture
IEC 60364-7-714	External lighting installations
IEC 60364-7-715	Extra-low-voltage lighting installations
IEC 60364-7-717	Mobile or transportable units
IEC 60364-7-718	Communal facilities and workplaces
IEC 60364-7-721	Electrical installations in caravans and motor caravans
IEC 60364-7-722	Supplies for electric vehicles
IEC 60364-7-729	Operating or maintenance gangways
IEC 60364-7-740	Temporary electrical installations for structures, amusement devices and booths at fairgrounds, amusement parks and circuses
IEC 60364-7-753	Heating cables and embedded heating systems

The specific requirements in these standards may include, for example, some of the following:

- Additional equipotential bonding
- Zones where it is forbidden to install any electrical appliance
- Zones with additional requirement on electrical appliances that can be installed (class II)
- Zones where only specific circuits can be used (SELV)
- Mandatory protection of some circuits by 30mA RCDs
- Additional protection against fire risks
- Requirements on the installation position of some equipment (height between x and y)

As an example, see [section 2 Bathroom and showers](#), focused on IEC 60364-7-701.

Chapter R

EMC guidelines

1	Electrical distribution	R2
2	Earthing principles and structures	R3
3	Implementation	R5
	3.1 Equipotential bonding inside and outside buildings	R5
	3.2 Improving equipotential conditions	R5
	3.3 Separating cables	R7
	3.4 Raised floors	R7
	3.5 Cable running.....	R8
	3.6 Busway	R11
	3.7 Implementation of shielded cables	R11
	3.8 Communication networks.....	R13
	3.9 Implementation of surge arresters	R15
	3.10 Cabinet cabling.....	R15
	3.11 Standards.....	R18
	3.12 Electrostatic discharge protection	R18
4	Coupling mechanisms and counter-measures	R20
	4.1 General.....	R20
	4.2 Common-mode impedance coupling	R21
	4.3 Capacitive coupling	R22
	4.4 Inductive coupling.....	R23
	4.5 Radiated coupling.....	R24
5	Wiring recommendations	R26
	5.1 Signal classes	R26
	5.2 Wiring recommendations	R26

1 Electrical distribution

The system earthing arrangement must be properly selected to ensure the safety of life and property. The behaviour of the different systems with respect to EMC considerations must be taken into account. **Fig. R1** below presents a summary of their main characteristics.

European standards (see EN 50174-2, EN 50310 and HD 60364-4-444) recommend the TN-S earthing system which causes the fewest EMC problems for installations comprising information-technology equipment (including telecom equipment).

	TT	TN-S	IT	TN-C
Safety of persons	Correct Use of residual current devices (circuit breaker) is mandatory	Correct Continuity of the PE conductor must be ensured throughout the installation		
Safety of property	Correct	Poor	Correct	Poor
	Medium ground-fault current (< about ten amps)	High ground-fault current (about 1 kA)	Low ground-fault current for first fault (< about ten mA), but high for second fault	High ground-fault current (about 1 kA)
Availability of energy	Correct	Correct	Excellent	Correct
EMC performance	Correct - Risk of overvoltages - Equipotential problems - Need to manage devices with high leakage currents	Excellent - Good equipotential situation - Need to manage devices with high leakage currents - High ground-fault currents (transient disturbances)	Poor (to be avoided) - Risk of overvoltages - Common-mode filters and surge arrestors must handle the phase to-phase voltages - RCDs subject to nuisance tripping if common-mode capacitors are present - Equivalent to TN system for second fault	Poor (not recommended) - Neutral and PE are combined - 50/60 Hz and harmonics currents circulate in the earthing and grounding structures - High ground-fault currents (transient disturbances)

Fig. R1 Main characteristics of the different earthing systems

When an installation includes high-power equipment (motors, air-conditioning, lifts, power electronics, etc.), it is advised to install one or more transformers specifically for these systems. Electrical distribution must be organised in a star system and all outgoing circuits must exit the main low-voltage switchboard (MLVS).

Electronic systems (control/monitoring, regulation, measurement instruments, etc.) must be supplied by a dedicated transformer in a TN-S system.

Fig. R2 below illustrates these recommendations.

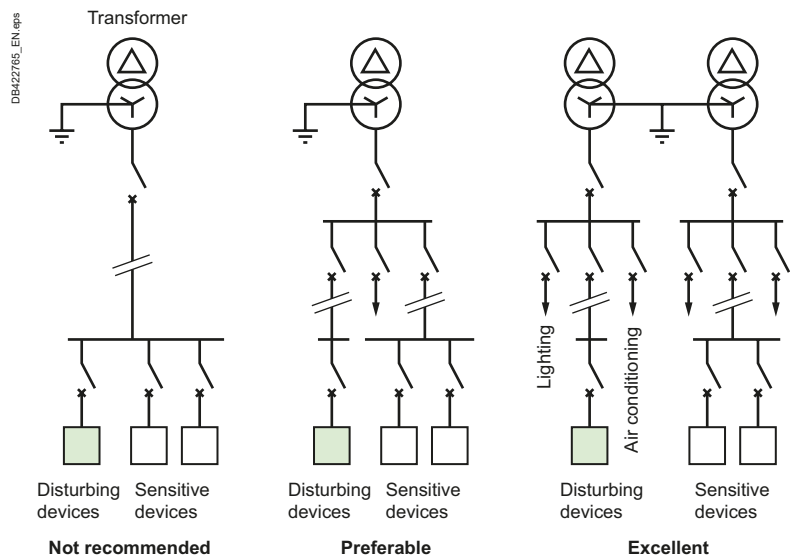


Fig. R2 Recommendations of separated distributions

2 Earthing principles and structures

This section deals with the earthing and equipotential bonding of information-technology devices and other similar devices requiring interconnections for signalling purposes.

Earthing networks are designed to fulfil a number of functions. They can be independent or operate together to provide one or more of the following:

- Safety of persons with respect to electrical hazards
- Protection of equipment with respect to electrical hazards
- A reference value for reliable, high-quality signals
- Satisfactory EMC performance

The system earthing arrangement is generally designed and installed in view of obtaining a low impedance capable of diverting fault currents and HF currents away from electronic devices and systems. There are different types of system earthing arrangements and some require that specific conditions be met. These conditions are not always met in typical installations. The recommendations presented in this section are intended for such installations.

For professional and industrial installations, a common bonding network (CBN) may be useful to ensure better EMC performance with respect to the following points:

- Digital systems and new technologies
 - Compliance with the EMC essential requirements of Directive 2004/108/EC (emission and immunity)
 - The wide number of electrical applications
 - A high level of system safety and security, as well as reliability and/or availability
- For residential premises, however, where the use of electrical devices is limited, an isolated bonding network (IBN) or, even better, a mesh IBN may be a solution.

It is now recognised that independent, dedicated earth electrodes, each serving a separate earthing network, are a solution that is not acceptable in terms of EMC, but also represent a serious safety hazard. In certain countries, the national building codes forbid such systems.

Use of a separate "clean" earthing network for electronics and a "dirty" earthing network for energy is not recommended in view of obtaining correct EMC, even when a single electrode is used (see Fig. R3 and Fig. R4). In the event of a lightning strike, a fault current or HF disturbances as well as transient currents will flow in the installation. Consequently, transient voltages will be created and result in failures or damage to the installation. If installation and maintenance are carried out properly, this approach may be dependable (at power frequencies), but it is generally not suitable for EMC purposes and is not recommended for general use.

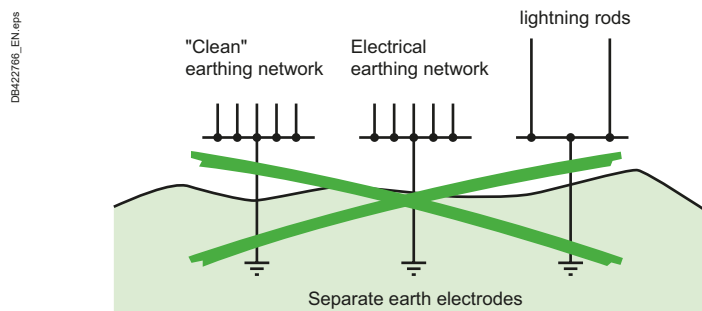


Fig. R3 Independent earth electrodes, a solution generally not acceptable for safety and EMC reasons

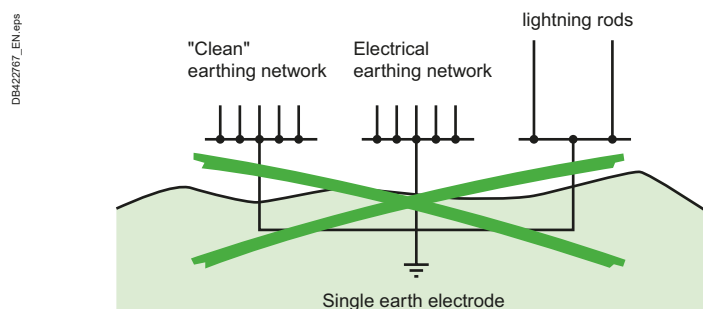


Fig. R4 Installation with a single earth electrode

2 Earthing principles and structures

The recommended configuration for the earthing network and electrodes is two or three dimensional (see Fig. R5). This approach is advised for general use, both in terms of safety and EMC. This recommendation does not exclude other special configurations that, when correctly maintained, are also suitable.

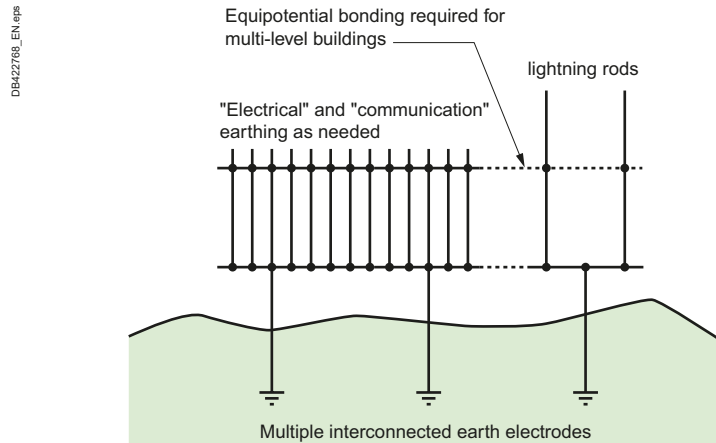


Fig. R5 Installation with multiple earth electrodes

In a typical installation for a multi-level building, each level should have its own earthing network (generally a mesh) and all the networks must be both interconnected and connected to the earth electrode. At least two connections are required (built in redundancy) to ensure that, if one conductor breaks, no section of the earthing network is isolated.

Practically speaking, more than two connections are made to obtain better symmetry in current flow, thus reducing differences in voltage and the overall impedance between the various levels in the building.

The many parallel paths have different resonance frequencies. If one path has a high impedance, it is most probably shunted by another path with a different resonance frequency. On the whole, over a wide frequency spectrum (dozens of Hz and MHz), a large number of paths results in a low-impedance system (see Fig. R6).

Each room in the building should have earthing-network conductors for equipotential bonding of devices and systems, cableways, trunking systems and structures. This system can be reinforced by connecting metal pipes, gutters, supports, frames, etc. In certain special cases, such as control rooms or computers installed on false floors, ground reference plane or earthing strips in areas for electronic systems can be used to improve earthing of sensitive devices and protection interconnection cables.

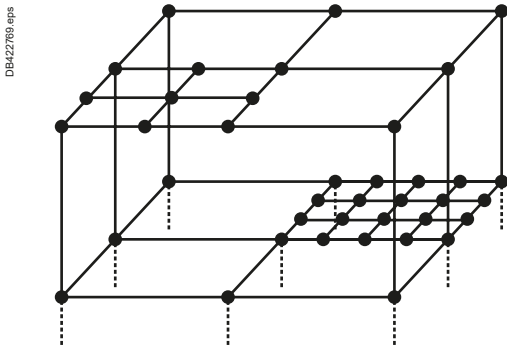


Fig. R6 Each level has a mesh and the meshes are interconnected at several points between levels. Certain ground-floor meshes are reinforced to meet the needs of certain areas

3.1 Equipotential bonding inside and outside buildings

The fundamental goals of earthing and bonding are the following:

- **Safety:** by limiting the touch voltage and the return path of fault currents,
- **EMC:** by avoiding differences in potential and providing a screening effect.

Stray currents are inevitably propagated in an earthing network. It is impossible to eliminate all the sources of disturbances for a site. Earth loops are also inevitable. When a magnetic field affects a site, e.g. the field created by lightning, differences in potential are created in the loops formed by the various conductors and the currents flowing in the earthing system. Consequently, the earthing network is directly affected by any counter-measures taken outside the building.

As long as the currents flow in the earthing system and not in the electronic circuits, they do no damage. However, when earthing networks are not equipotential, e.g. when they are star connected to the earth electrode, the HF stray currents will flow wherever they can, including in control wires. Equipment can be disturbed, damaged or even destroyed.

The only inexpensive means to divide the currents in an earthing system and maintain satisfactory equipotential characteristics is to interconnect the earthing networks. This contributes to better equipotential bonding within the earthing system, but does not remove the need for protective conductors. To meet legal requirements in terms of the safety of persons, sufficiently sized and identified protective conductors must remain in place between each piece of equipment and the earthing terminal. What is more, with the possible exception of a building with a steel structure, a large number of conductors for the lightning rods or the lightning-protection network must be directly connected to the earth electrode.

The fundamental difference between a protective conductor (PE) and a lightning rod down-conductor is that the first conducts internal currents to the neutral of the MV/LV transformer whereas the second carries external current (from outside the installation) to the earth electrode.

In a building, it is advised to connect an earthing network to all accessible conducting structures, namely metal beams and door frames, pipes, etc.

It is generally sufficient to connect metal trunking, cable trays and lintels, pipes, ventilation ducts, etc. at as many points as possible. In places where there is a large amount of equipment and the size of the mesh in the bonding network is greater than four metres, an equipotential conductor should be added. The size and type of conductor are not of critical importance.

It is imperative to interconnect the earthing networks of buildings that have shared cable connections. Interconnection of the earthing networks must take place via a number of conductors and all the internal metal structures of the buildings or linking the buildings (on the condition that they are not interrupted).

In a given building, the various earthing networks (electronics, computing, telecom, etc.) must be interconnected to form a single equipotential bonding network.

This earthing-network must be as meshed as possible. If the earthing network is equipotential, the differences in potential between communicating devices will be low and a large number of EMC problems disappear. Differences in potential are also reduced in the event of insulation faults or lightning strikes.

If equipotential conditions between buildings cannot be achieved or if the distance between buildings is greater than ten metres, it is highly recommended to use optical fibre for communication links and galvanic insulators for measurement and communication systems.

These measures are mandatory if the electrical supply system uses the IT or TN-C system.

3.2 Improving equipotential conditions

Bonding networks

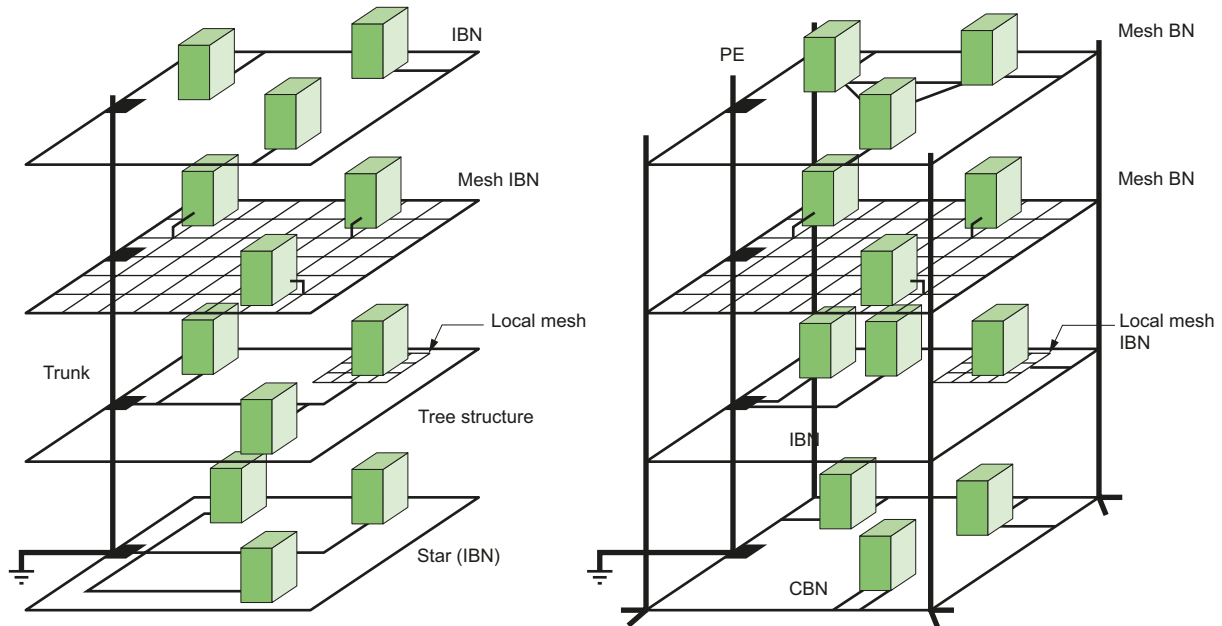
Even though the ideal bonding network would be made of sheet metal or a fine mesh, experience has shown that for most disturbances, a three-metre mesh size is sufficient to create a mesh bonding network.

Examples of different bonding networks are shown in **Fig. R7** next page.

The minimum recommended structure comprises a conductor (e.g. copper cable or strip) surrounding the room.

3 Implementation

DB422770_EN.eps



BN: Bonding network
 CBN: Common bonding network
 IBN: Isolated bonding network

Fig. R7 Examples of bonding networks

The length of connections between a structural element and the bonding network does not exceed 50 centimetres and an additional connection should be installed in parallel at a certain distance from the first. The inductance of the connection between the earthing bar of the electrical enclosure for a set of equipment and the bonding network (see below) should be less than one μHenry ($0.5 \mu\text{H}$, if possible). For example, it is possible to use a single 50 cm conductor or two parallel conductors one meter long, installed at a minimum distance from one another (at least 50 cm) to reduce the mutual inductance between the two conductors.

Where possible, connection to the bonding network should be at an intersection to divide the HF currents by four without lengthening the connection. The profile of the bonding conductors is not important, but a flat profile is preferable. The conductor should also be as short as possible.

Parallel earthing conductor (PEC)

The purpose of a parallel earthing conductor is to reduce the common-mode current flowing in the conductors that also carry the differential-mode signal (the common-mode impedance and the surface area of the loop are reduced).

The parallel earthing conductor must be designed to handle high currents when it is used for protection against lightning or for the return of high fault currents. When cable shielding is used as a parallel earthing conductor, it cannot handle such high currents and the solution is to run the cable along metal structural elements or cableways which then act as other parallel earthing conductors for the entire cable. Another possibility is to run the shielded cable next to a large parallel earthing conductor with both the shielded cable and the parallel earthing conductor connected at each end to the local earthing terminal of the equipment or the device.

For very long distances, additional connections to the network are advised for the parallel earthing conductor, at irregular distances between the devices. These additional connections form a shorter return path for the disturbing currents flowing through the parallel earthing conductor. For U-shaped trays, shielding and tubes, the additional connections should be external to maintain the separation with the interior ("screening" effect).

Bonding conductors

Bonding conductors may be metal strips, flat braids or round conductors. For high-frequency systems, metal strips and flat braids are preferable (skin effect) because a round conductor has a higher impedance than a flat conductor with the same cross section. Where possible, the length to width ratio should not exceed 5.

3.3 Separating cables

The physical separation of high and low-current cables is very important for EMC, particularly if low-current cables are not shielded or the shielding is not connected to the exposed conductive parts (ECPs). The sensitivity of electronic equipment is in large part determined by the accompanying cable system.

If there is no separation (different types of cables in separate cableways, minimum distance between high and low-current cables, types of cableways, etc.), electromagnetic coupling is at its maximum. Under these conditions, electronic equipment is sensitive to EMC disturbances flowing in the affected cables.

Use of busbar trunking systems such as Canalis or busbar ducts for high power ratings is strongly advised. The levels of radiated magnetic fields using these types of trunking systems is 10 to 20 times lower than standard cables or conductors.

The recommendations in the "Cable running" and "Wiring recommendations" sections should be taken into account.

3.4 Raised floors

The inclusion of the floors in the mesh contributes to equipotentiality of the area and consequently to the distribution and dilution of disturbing LF currents.

The screening effect of a raised floor is directly related to its equipotentiality. If the contact between the floor tiles is poor (rubber antistatic joints, for example) or if the contact between the support brackets is faulty (pollution, corrosion, dust, etc. or if there are no support brackets), it is necessary to add an equipotential mesh.

In this case, it is sufficient to ensure effective electrical connections between the metal pedestals. Small spring clips are available on the market to connect the metal pedestals to the equipotential mesh. Ideally, each pedestal should be connected, but it is often sufficient to connect every other pedestals in each direction. A mesh 1.5 to 2 metres in size is suitable in most cases.

The recommended cross-sectional area of the copper is 10 mm² or more. In general, a flat braid is used. To reduce the effects of corrosion, it is advised to use tin-plated copper (see Fig. R8).

Perforated floor tiles act like normal floor tiles when they have a cellular steel structure.

Preventive maintenance is required for the floor tiles approximately every five years (depending on the type of tile plate and the environment, including humidity, dust and corrosion). Rubber or polymer antistatic joints must be maintained, similar to the bearing surfaces of the floor tiles (cleaning with a suitable product).

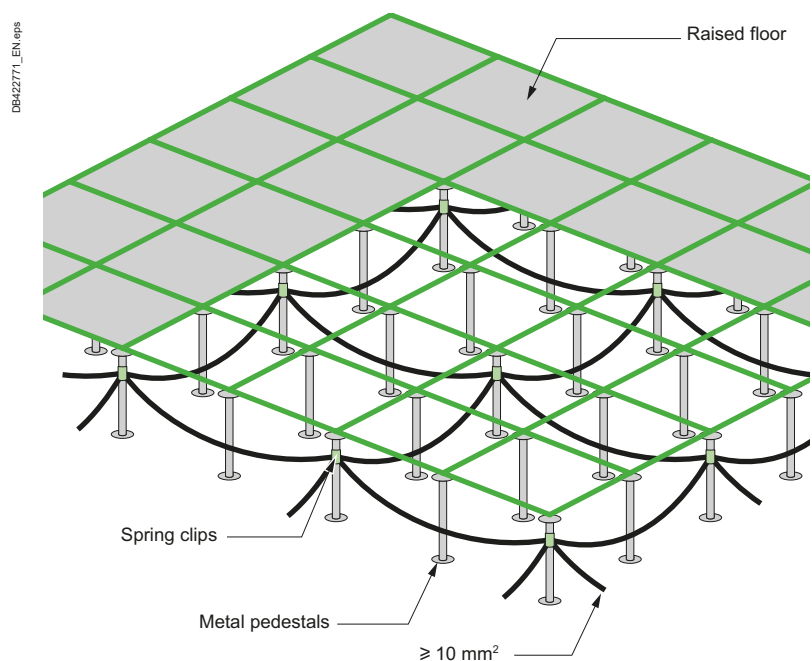


Fig. R8 Raised floor implementation

3.5 Cable running

Selection of materials and their shape depends on the following criteria:

- Severity of the EM environment along cableways (proximity of sources of conducted or radiated EM disturbances)
- Authorised level of conducted and radiated emissions
- Type of cables (shielded?, twisted?, optical fibre?)
- EMI withstand capacity of the equipment connected to the wiring system
- Other environmental constraints (chemical, mechanical, climatic, fire, etc.)
- Future extensions planned for the wiring system

Non-metal cableways are suitable in the following cases:

- A continuous, low-level EM environment
- A wiring system with a low emission level
- Situations where metal cableways should be avoided (chemical environment)
- Systems using optical fibres

For metal cableways, it is the shape (flat, U-shape, tube, etc.) rather than the cross-sectional area that determines the characteristic impedance. Closed shapes are better than open shapes because they reduce common-mode coupling. Cableways often have slots for cable straps. The smaller the better. The types of slots causing the fewest problems are those cut parallel and at some distance from the cables. Slots cut perpendicular to the cables are not recommended (seen [Fig. R9](#)).

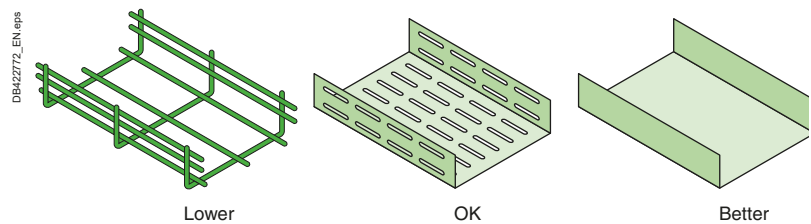


Fig. R9 CEM performance of various types of metal cableways

In certain cases, a poor cableway in EMI terms may be suitable if the EM environment is low, if shielded cables or optical fibres are employed, or separate cableways are used for the different types of cables (power, data processing, etc.).

It is a good idea to reserve space inside the cableway for a given quantity of additional cables. The height of the cables must be lower than the partitions of the cableway as shown below. Covers also improve the EMC performance of cableways.

In U-shaped cableways, the magnetic field decreases in the two corners. That explains why deep cableways are preferable (see [Fig. R10](#)).

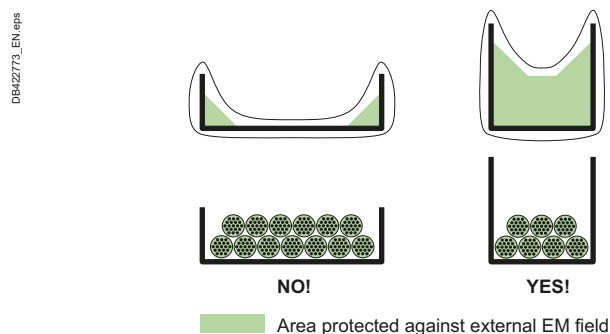


Fig. R10 Installation of different types of cables

Different types of cables (power and low-level cables) should not be installed in the same bundle or in the same cableway. Cableways should never be filled to more than half capacity.

R - EMC guidelines

3 Implementation

It is recommended to electromagnetically separate groups from one another, either using shielding or by installing the cables in different cableways. The quality of the shielding determines the distance between groups. If there is no shielding, sufficient distances must be maintained (see Fig. R11).

The distance between power and control cables must be at least 5 times the radius of the larger power cable.

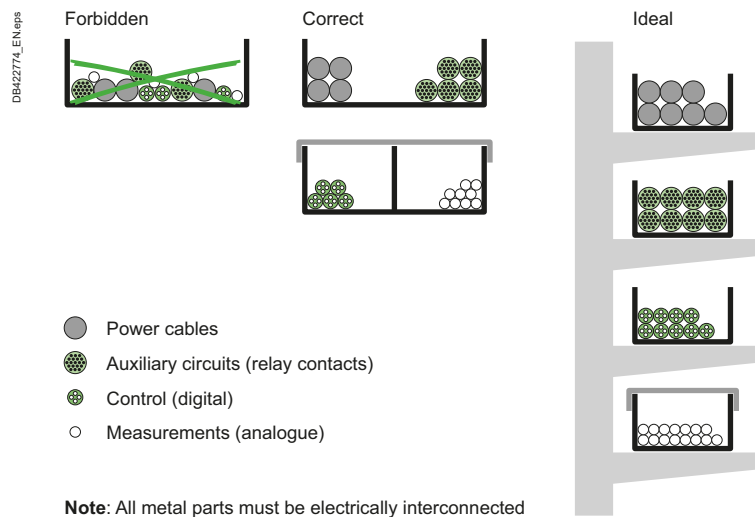


Fig. R11 Recommendation to install groups of cables in metal cableways

Metal building components can be used for EMC purposes. Steel beams (L, H, U or T shaped) often form an uninterrupted earthed structure with large transversal sections and surfaces with numerous intermediate earthing connections. Cables should if possible be run along such beams. Inside corners are better than the outside surfaces (see Fig. R12).

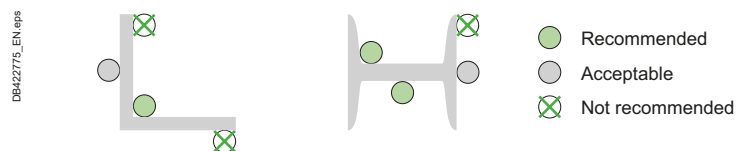


Fig. R12 Recommendation to install cables in steel beams

Both ends of metal cableways must always be connected to local earth network. For very long cableways, additional connections to the earthing system are recommended between connected devices. Where possible, the distance between these earthing connections should be irregular (for symmetrical wiring systems) to avoid resonance at identical frequencies. All connections to the earthing system should be short.

Metal and non-metal cableways are available. Metal solutions offer better EMC characteristics. A cableway (cable trays, conduits, cable brackets, etc.) must offer a continuous, conducting metal structure from beginning to end.

An aluminium cableway has a lower DC resistance than a steel cableway of the same size, but the transfer impedance (Z_t) of steel drops at a lower frequency, particularly when the steel has a high relative permeability μ_r . Care must be taken when different types of metal are used because direct electrical connection is not authorised in certain cases to avoid corrosion. That could be a disadvantage in terms of EMC.

When devices connected to the wiring system using unshielded cables are not affected by low-frequency disturbances, the EMC of non-metal cableways can be improved by adding a parallel earthing conductor (PEC) inside the cableway. Both ends must be connected to the local earthing system. Connections should be made to a metal part with low impedance (e.g. a large metal panel of the device case).

The PEC should be designed to handle high fault and common-mode currents.

3 Implementation

Implementation

When a metal cableway is made up of a number of short sections, care is required to ensure continuity by correctly bonding the different parts. The parts should preferably be welded along all edges. Riveted, bolted or screwed connections are authorised as long as the contact surfaces conduct current (no paint or insulating coatings) and are protected against corrosion. Tightening torques must be observed to ensure correct pressure for the electrical contact between two parts.

When a particular shape of cableway is selected, it should be used for the entire length. All interconnections must have a low impedance. A single wire connection between two parts of the cableway produces a high local impedance that cancels its EMC performance.

Starting at a few MHz, a ten-centimetre connection between two parts of the cableway reduces the attenuation factor by more than a factor of ten (see Fig. R13).

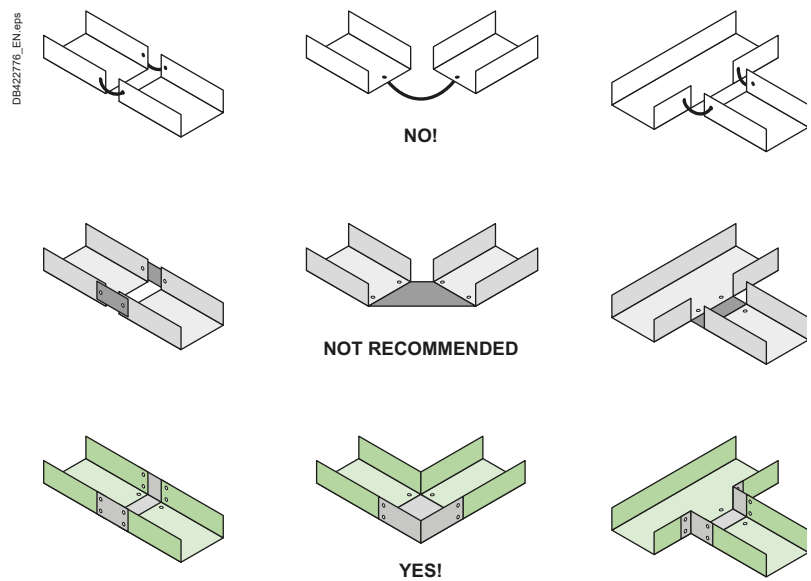


Fig. R13 Metal cableways assembly

Each time modifications or extensions are made, it is very important to make sure they are carried out according to EMC rules (e.g. never replace a metal cableway by a plastic version!).

Covers for metal cableways must meet the same requirements as those applying to the cableways themselves. A cover should have a large number of contacts along the entire length. If that is not possible, it must be connected to the cableway at least at the two ends using short connections (e.g. braided or meshed connections).

When cableways must be interrupted to pass through a wall (e.g. firewalls), low-impedance connections must be used between the two parts (see Fig. R14).

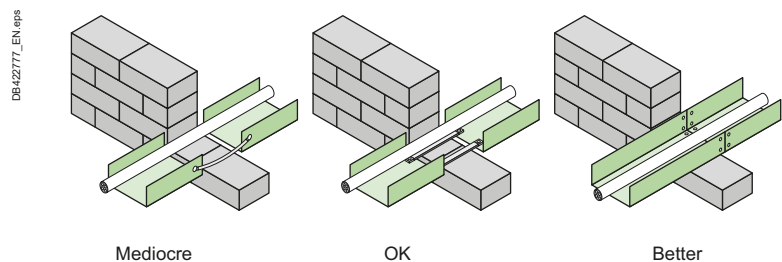


Fig. R14 Recommendation for metal cableways assembly to pass through a wall

PB110834_eps



Fig. R15 Power cables and metallic busways magnetic field radiations

3.6 Busway

Busways reduce the risk of exposure to electromagnetic fields.

According to the WHO (World Health Organisation), exposure to electromagnetic fields can be a health hazard starting at levels as low as 0.2 micro-Teslas and could represent a long-term risk of cancer. Some countries have created standards that stipulate limits (e.g. 0.2 μT at 1 metre in Sweden).

All electrical conductors generate magnetic fields proportional to the distance between them. The design of busbar trunking with tightly spaced conductors in a metal enclosure helps to considerably reduce radiated electromagnetic fields.

The electromagnetic field characteristics of busbar trunking are well defined and measurements show that they are far below potentially dangerous levels (see Fig. R16).

In specific cases, where particularly low values are required (computer rooms, medical rooms, some offices), it is important to minimize the magnetic induction generated by power cables.

Magnetic induction is:

- proportional to the current
- proportional to the distance between the conductors
- inversely proportional to the square of the distance with respect to the busbar.

Busbar with a steel casing provides a good screening effect compared to power cables: magnetic field reduced from 2 to 30 times, depending on the Canalis model.

This is particularly low because of the short distance between the bars and the additional attenuation provided by the steel casing.

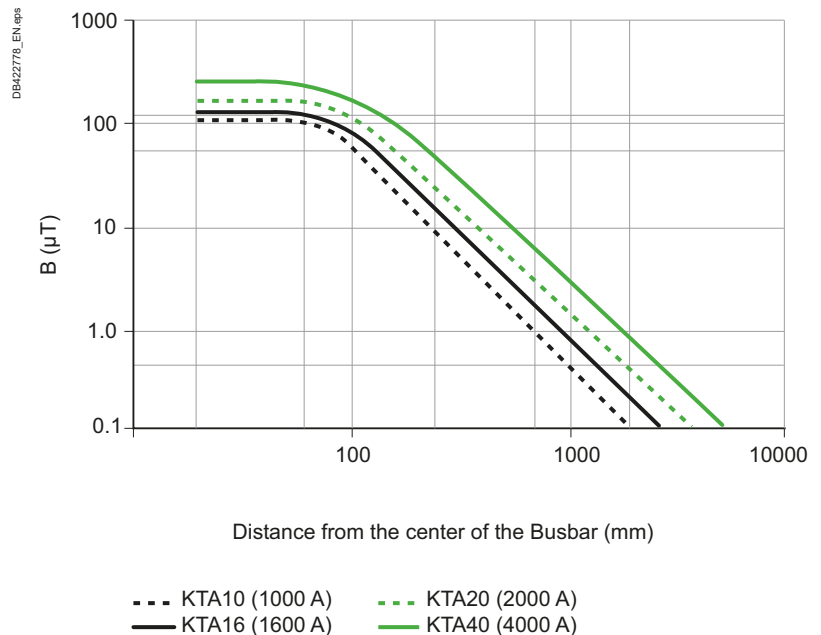


Fig. R16 Canalis busbar trunking system data

3.7 Implementation of shielded cables

When the decision is made to use shielded cables, it is also necessary to determine how the shielding will be bonded (type of earthing, connector, cable entry, etc.), otherwise the benefits are considerably reduced. To be effective, the shielding should be bonded over 360° Fig. R17 on the next page show different ways of earthing the cable shielding.

For computer equipment and digital links, the shielding should be connected at each end of the cable.

Connection of the shielding is very important for EMC and the following points should be noted.

R - EMC guidelines

3 Implementation

If the shielded cable connects equipment located in the same equipotential bonding area, the shielding must be connected to the exposed conductive parts (ECP) at both ends. If the connected equipment is not in the same equipotential bonding area, there are a number of possibilities.

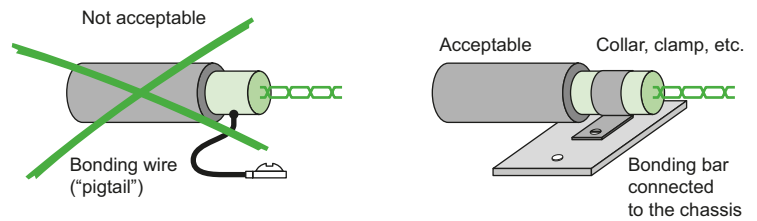
- Connection of only one end to the ECPs is dangerous. If an insulation fault occurs, the voltage in the shielding can be fatal for an operator or destroy equipment. In addition, at high frequencies, the shielding is not effective.

- Connection of both ends to the ECPs can be dangerous if an insulation fault occurs. A high current flows in the shielding and can damage it. To limit this problem, a parallel earthing conductor (PEC) must be run next to the shielded cable. The size of the PEC depends on the short-circuit current in the given part of the installation.

It is clear that if the installation has a well meshed earthing network, this problem does not arise.

DB422775_EN.eps

All bonding connections must be made to bare metal



Poorly connected shielding = reduced effectiveness

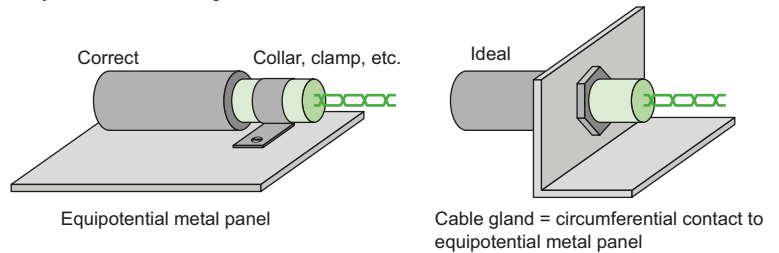


Fig. R17 Implementation of shielded cables

The following Fig. R18 shows how to prepare the screen when EMC clamps are used.

DB422780_EN.eps

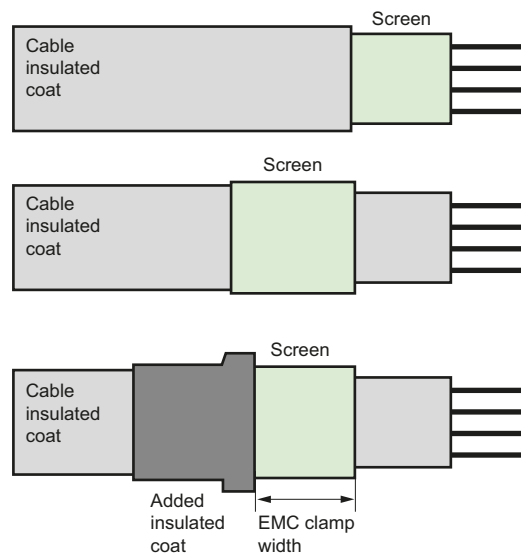


Fig. R18 Recommended screen preparation

3.8 Communication networks

It is highly recommended to follow the European Standards EN 50173 series to perform Information Technology cabling.

To ensure a reliable data transmission, the quality of the whole link shall be homogeneous. That means the category of the different cables shall be the same, the connecting interfaces shall be adapted to the cables.

Cables and connections of different categories may be mixed within a channel however the resultant performance will be determined by the category of the lowest performing component.

The shield continuity of the whole link (patch cords, Terminal Outlets, horizontal cable) shall be ensured and controlled by tests.

The Terminal Outlets (TO) could be used to earth the screen terminations in the cabinet. The choice of these TO is very important.

Communication networks are mostly extensive. They interconnect equipment located in different areas where the feeding power supplies could have different earthing systems.

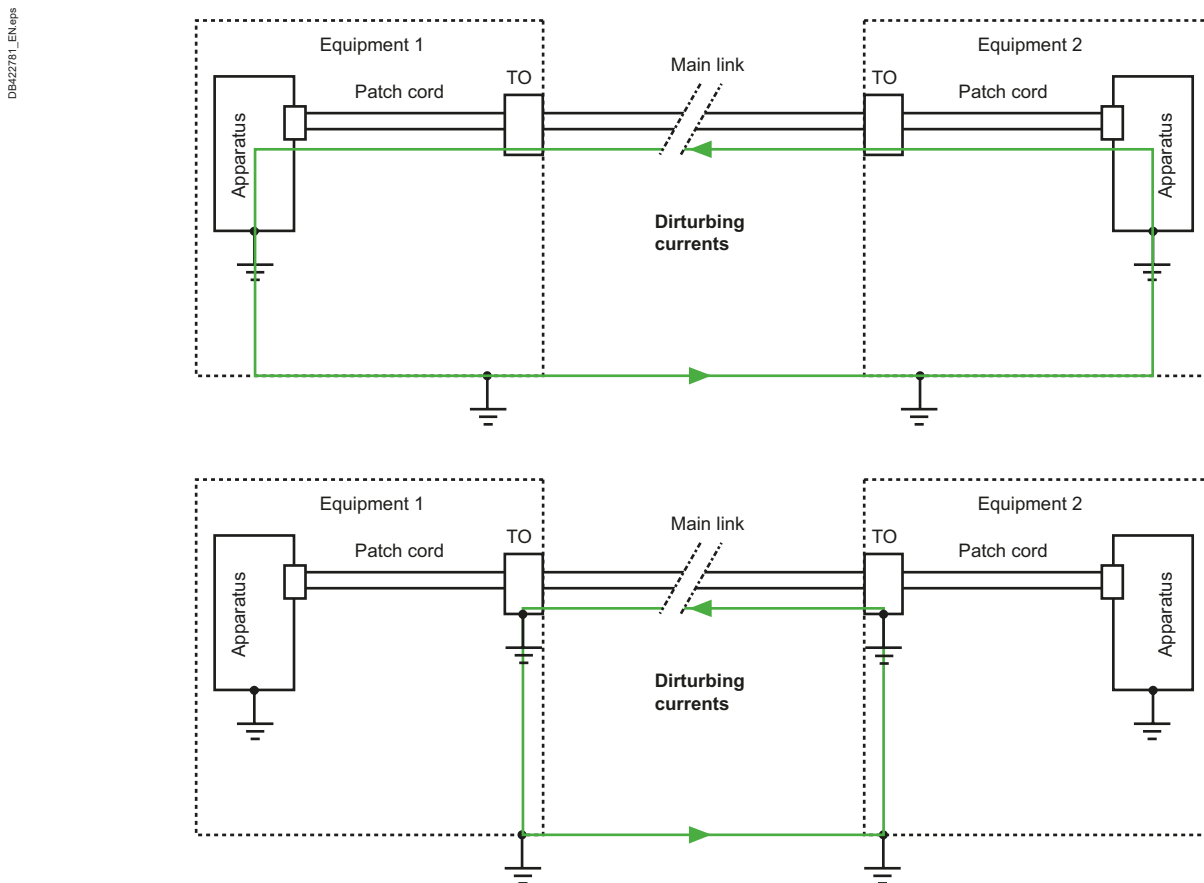


Fig. R19 How to reduce disturbing currents loop

If these different areas are not well equipotential, harsh transient currents could appear (lightning, main power fault, etc.) causing high voltage potential differences between interconnected equipment.

Communication interfaces (board, module, etc.) could be disturbed or damaged by this common mode over voltages.

The use of TN-S earthing system and well equipotential installation minimize this issue.

In any case, the use of Surge Protective Device (SPD) installed in Common Mode and/or Differential Mode is recommended.

3 Implementation

If the different areas/zones are not equipotential, if the power supply earthing system is TN-C or IT, or if there is a doubt and the previous 2 points, optical fiber links are highly recommended.

To avoid electrical safety issue, the optical fiber link should not have any metallic parts.

Protection against coils disturbances

AC and mostly DC Coils (relay, contactor, actuator, etc.) are very disturbing sources (see Fig. R20)

DE42782.eps

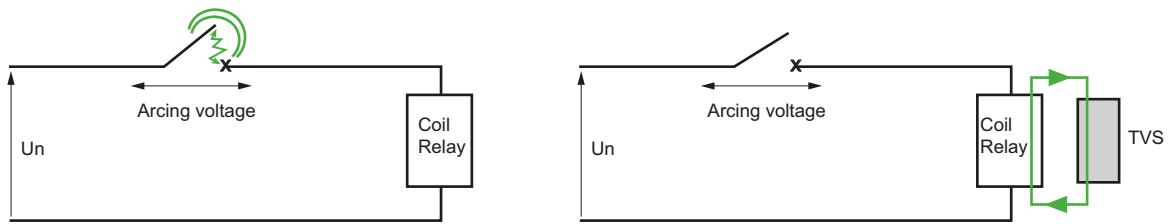


Fig. R20 TVS reduces the arcing voltage

To minimize these High Frequency disturbances the following solutions Fig. R21 could be implemented. (In grey, the preferred choice).

Symbol	Transient Voltage Suppression type	For AC	For DC	Overtoltage limitation	Contact fall time
	R-C network	Y	Y	2 to 3 . Un	1 to 2 times the standard time
	Metal Oxide Varistor	Y	Y	< 3 . Un	1.1 to 1.5 times the standard time
	Transient Voltage Suppression Diode Bidirectional	Y	Y	< 2 . Un	1.1 to 1.5 times the standard time
	Transient Voltage Suppression Diode Directional	N	Y	Un + 0.7 V	3 to 10 times the standard time
	Free wheeling diode	N	Y	Un + 0.7 V	3 to 10 times the standard time
	Resistor	Y	Y	< 4 . Un	1.5 to 2.5 times the standard time

Fig. R21 TVS table information

To be efficient, the TVS shall be installed closely to the coil.

3.9 Implementation of surge arresters

Refer to chapter J - paragraph 4 "Installation of SPDs"

3.10 Cabinet cabling (See Fig. R22)

Each cabinet must be equipped with an earthing bar or a ground reference metal sheet. All shielded cables and external protection circuits must be connected to this point. Anyone of the cabinet metal sheets or the DIN rail can be used as the ground reference.

Plastic cabinets are not recommended. In this case, the DIN rail must be used as ground reference.

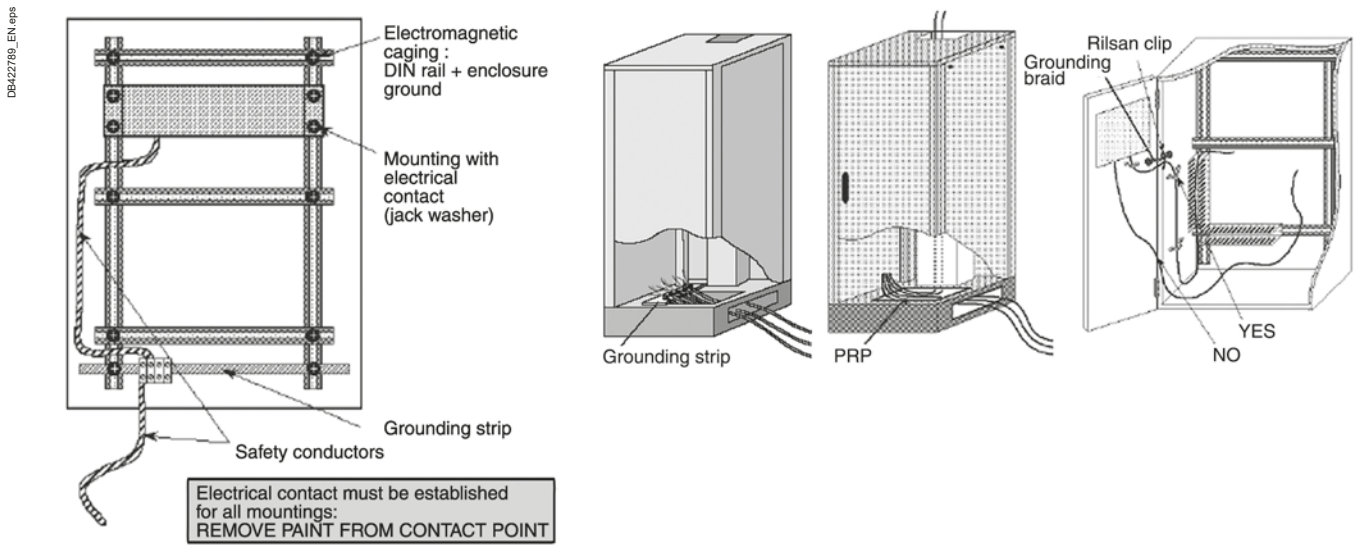


Fig. R22 Grounding and bonding examples

Cabinet cabling recommendations

Each cabinet, cubicle or enclosure shall be fitted, as a minimum, with an earthing bar and a reference metallic plate or grid (grounding plate). All the metallic parts (frames, panels, roof, door, etc.) shall be interconnected together with adapted features.

The use of specific washer is recommended. Some examples of preferred ones are shown below (see Fig. R23)

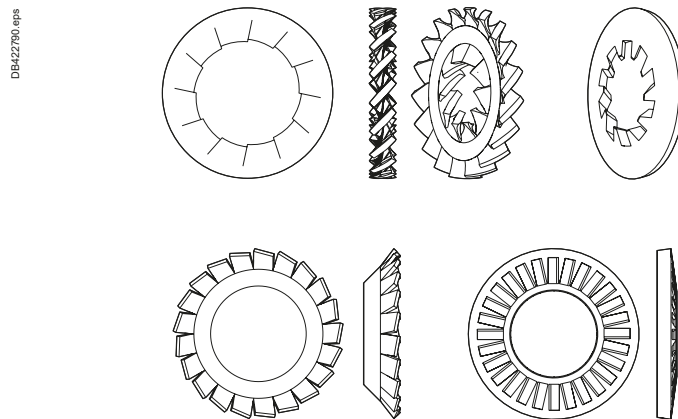


Fig. R23 Preferred washers examples

R - EMC guidelines

3 Implementation

DB422791_epps

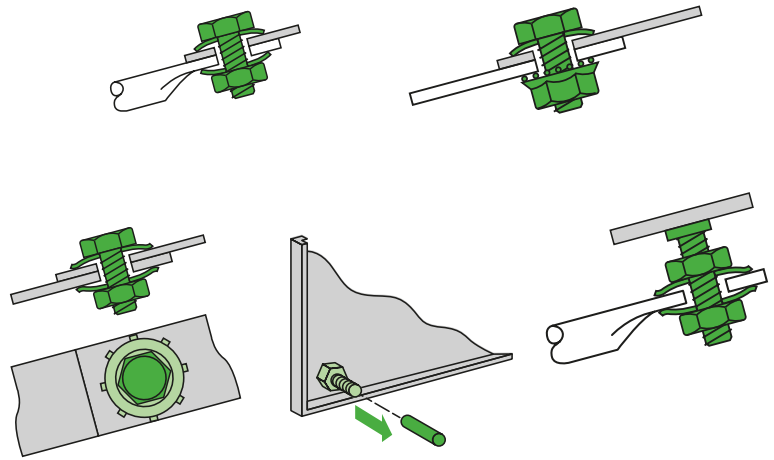


Fig. R24 Some examples of washers, bolt and lugs mounting.

DB422792_EN.epps

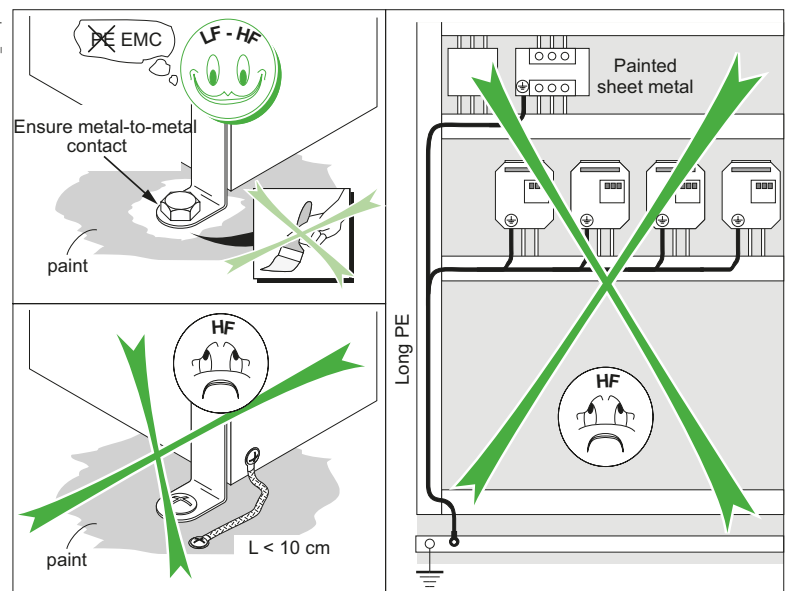


Fig. R25 Earthing and bonding examples

All the cables shall be laid on the grounded/earthed metallic structures.

All EMC components (e.g. EMI filter, EMC clamps) shall be fixed directly on the metallic plates without any insulating coating (e.g. free of paint or varnish).

3 Implementation

Screened cables coming or going out from the cubicle shall be bonded to the earthing bar or grounding plate if these cables are coming from long distance and/or from non equipotential zones.

The goal is to divert the disturbing currents at the cabinet entrance and not inside the cabinet.

Non metallic cabinet are not recommended for EMC purposes.

To protect electronics equipment against low frequency magnetic field, it is recommended to use (galvanized) steel cabinets.

Non magnetic metals (e.g. aluminum, stainless steel) are more efficient for high frequencies environment.

Power and low level apparatus shall be physically separated and cables segregation and distances between power and sensitive cables shall also be respected as shown on the figures below.

DB42793_EN.eps

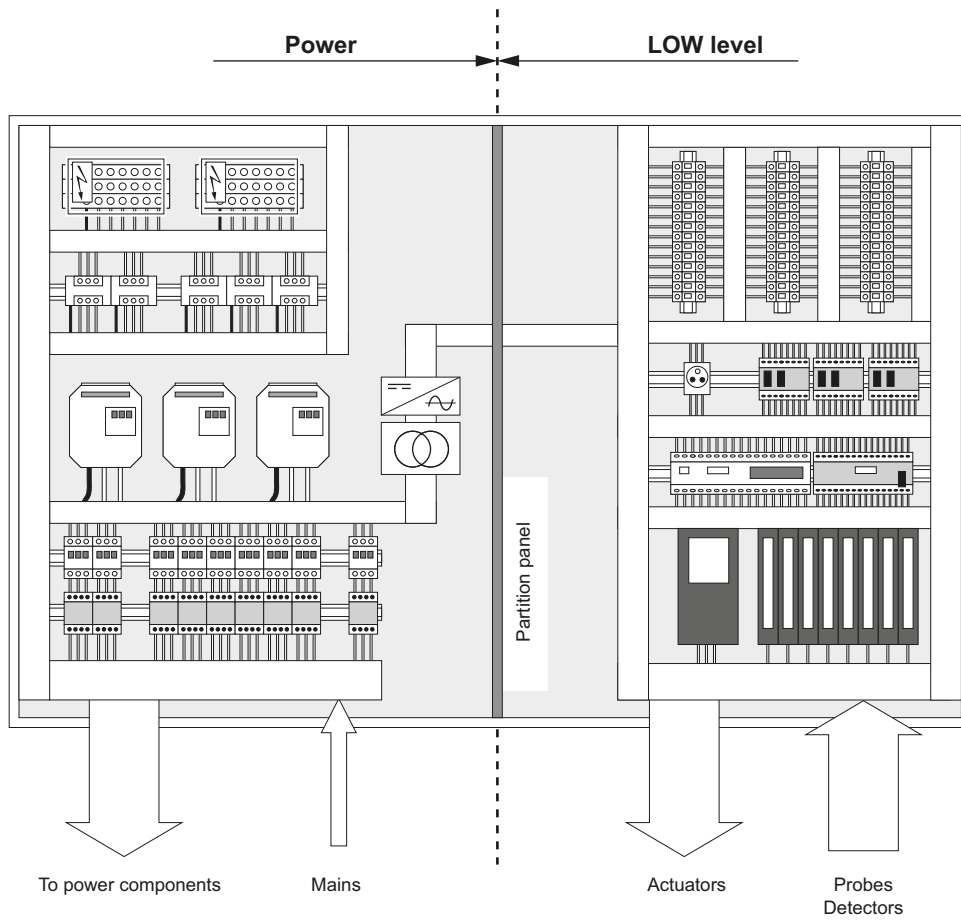


Fig. R26 Correct EMC design inside a same cabinet

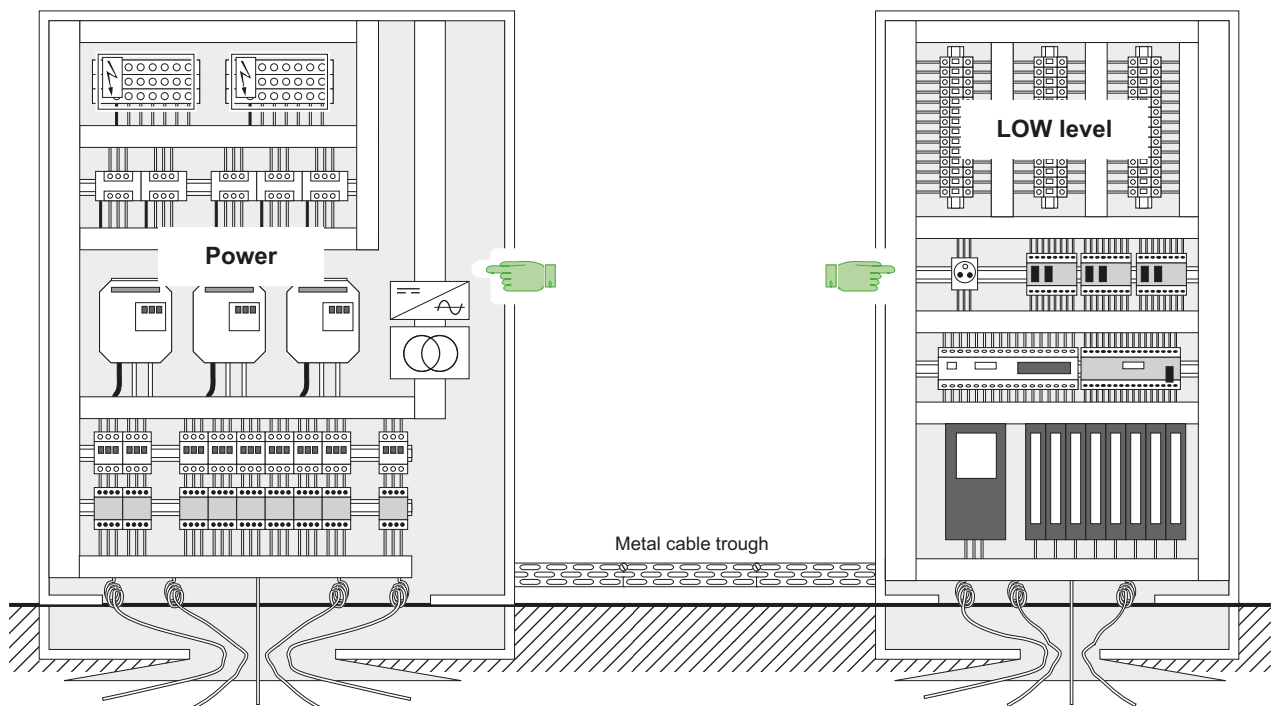


Fig. R27 Correct EMC design inside two separate cabinets

3.11 Standards

It is absolutely essential to specify the standards and recommendations that must be taken into account for installations.

Below are several documents that may be used:

- EN 50174-1 Information technology - Cabling installation. Part 1: Specification and quality assurance
- EN 50174-2 Information technology - Cabling installation. Part 2: Installation planning and practices inside buildings
- EN 50310 Application of equipotential bonding and earthing in buildings with information technology equipment.
- EN 50173 Information Technology - Generic cabling systems
- HD 60364-4-444 Low-voltage electrical installations Part 4-444: Protection for safety - Protection against voltage disturbances and electromagnetic disturbances

3.12 Electrostatic discharge protection

Normally, the use of specific tools or packages is required to handle or carry electronics boards or components (CPU, memory, analog, PCMCIA modules, etc.) which are sensitive to Electrostatic discharge (ESD).

Our products comply with standard ESD tests but ESD conditions are in some cases over the specs.

ESD threat could cause semiconductors aging and failures. Without any care, the semiconductor devices could be damaged or burned without users noticing.

Solution

The use of specific anti ESD wrist strap is highly recommended. This wrist strap shall be installed inside each cabinet and correctly connected to the earthed cabinet metallic frame.

Provide a procedure which depicts the good conditions of use.

An example is shown below.

ESD Wrist Strap (see Fig. R28)

Static electricity is produced by the contact and separation of materials: Shoes and floors, clothes and the human body, parts being moved on or from surfaces. The generated charge will reside on the body until it is discharged - the familiar "zap" that all of us have experienced. It's the "zap" that does the damage. If we can prevent any static charge from building up on the body, then there is essentially nothing to be discharged. A properly grounded wrist strap effectively prevents any static charge from building up. Any static charge that would tend to be created is instantly "drained" by the wrist strap. The wrist strap maintains the potential equilibrium that is accomplished the hard way with the "zap".

PB116835.eps



Fig. R28 ESD wrist strap examples

4 Coupling mechanisms and counter-measures

4.1 General

An EM interference phenomenon may be summed up in **Fig. R29** below.

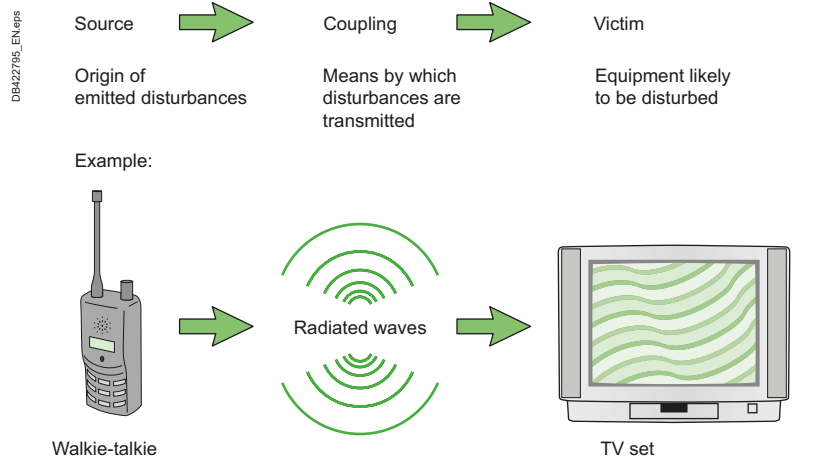


Fig. R29 EM interference phenomenon

The different sources of disturbances are:

- Radio-frequency emissions
- Wireless communication systems (radio, TV, CB, radio telephones, remote controls)
- Radar
- Electrical equipment
- High-power industrial equipment (induction furnaces, welding machines, stator control systems)
- Office equipment (computers and electronic circuits, photocopy machines, large monitors)
- Discharge lamps (neon, fluorescent, flash, etc.)
- Electromechanical components (relays, contactors, solenoids, current interruption devices)
- Power systems
- Power transmission and distribution systems
- Electrical transportation systems
- Lightning
- Electrostatic discharges (ESD)
- Electromagnetic nuclear pulses (EMNP)

The potential victims are:

- Radio and television receivers, radar, wireless communication systems
- Analogue systems (sensors, measurement acquisition, amplifiers, monitors)
- Digital systems (computers, computer communications, peripheral equipment)

The different types of coupling are:

- Common-mode impedance (galvanic) coupling
- Capacitive coupling
- Inductive coupling
- Radiated coupling (cable to cable, field to cable, antenna to antenna)

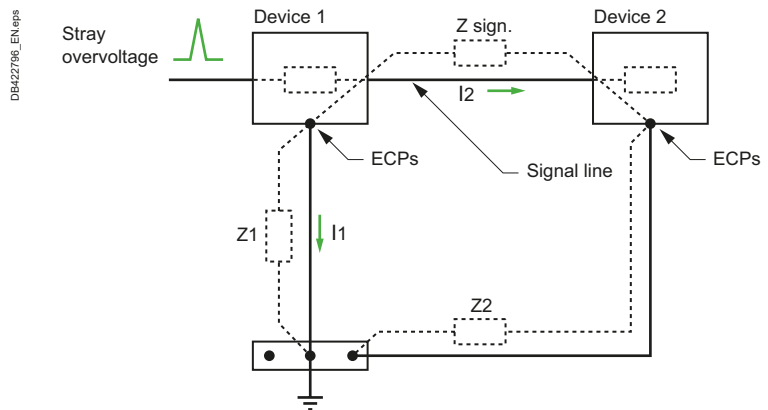
4 Coupling mechanisms and counter-measures

4.2 Common-mode impedance coupling

Definition

Two or more devices are interconnected by the power supply and communication cables (see Fig. R30). When external currents (lightning, fault currents, disturbances) flow via these common-mode impedances, an undesirable voltage appears between points A and B **which are supposed to be equipotential**. This stray voltage can disturb low-level or fast electronic circuits.

All cables, including the protective conductors, have an impedance, particularly at high frequencies.



The exposed conductive parts (ECP) of devices 1 and 2 are connected to a common earthing terminal via connections with impedances Z1 and Z2.

The stray overvoltage flows to the earth via Z1. The potential of device 1 increases to Z1 I1. The difference in potential with device 2 (initial potential = 0) results in the appearance of current I2.

$$Z_1 I_1 = (Z_{\text{sign}} + Z_2) I_2 \Rightarrow \frac{I_2}{I_1} = \frac{Z_1}{(Z_{\text{sign}} + Z_2)}$$

Current I2, present on the signal line, disturbs device 2.

Fig. R30 Definition of common-mode impedance coupling

Examples (see Fig. R31)

- Devices linked by a common reference conductor (e.g. PEN, PE) affected by fast or intense (di/dt) current variations (fault current, lightning strike, short-circuit, load changes, chopping circuits, harmonic currents, power factor correction capacitor banks, etc.)
- A common return path for a number of electrical sources

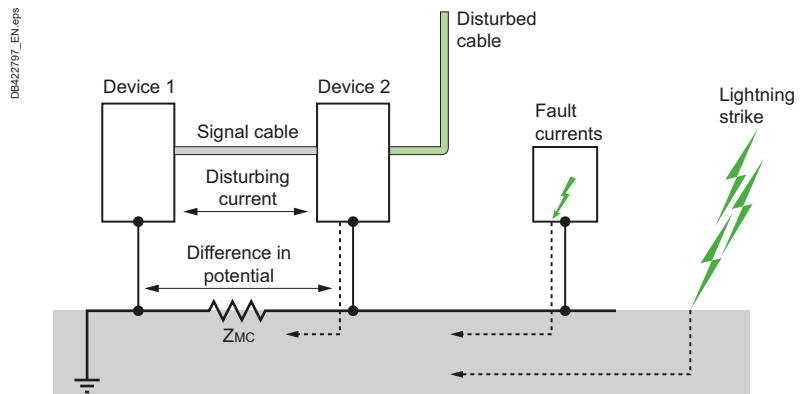


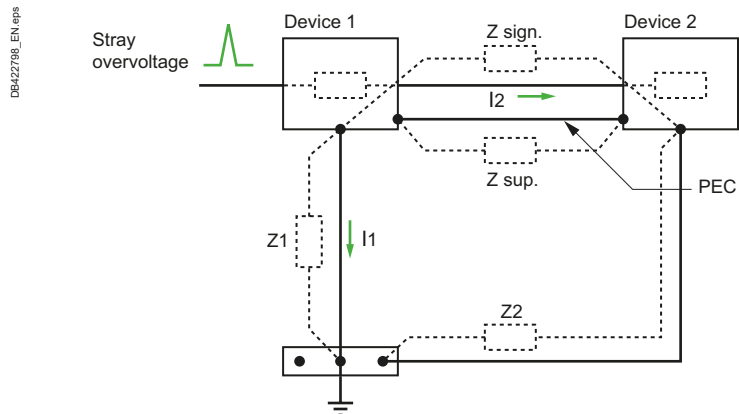
Fig. R31 Example of common-mode impedance coupling

4 Coupling mechanisms and counter-measures

Counter-measures (see Fig. R32)

If they cannot be eliminated, common-mode impedances must at least be as low as possible. To reduce the effects of common-mode impedances, it is necessary to:

- Reduce impedances:
 - Mesh the common references,
 - Use short cables or flat braids which, for equal sizes, have a lower impedance than round cables,
 - Install functional equipotential bonding between devices.
- Reduce the level of the disturbing currents by adding common-mode filtering and differential-mode inductors



If the impedance of the parallel earthing conductor PEC (Z_{sup}) is very low compared to Z_{sign} , most of the disturbing current flows via the PEC, i.e. not via the signal line as in the previous case.

The difference in potential between devices 1 and 2 becomes very low and the disturbance acceptable.

Fig. R32 Counter-measures of common-mode impedance coupling

4.3 Capacitive coupling

Definition

The level of disturbance depends on the voltage variations (dv/dt) and the value of the coupling capacitance between the disturber and the victim.

Capacitive coupling increases with:

- The frequency,
- The proximity of the disturber to the victim and the length of the parallel cables,
- The height of the cables with respect to a ground referencing plane,
- The input impedance of the victim circuit (circuits with a high input impedance are more vulnerable),
- The insulation of the victim cable (ϵ_r of the cable insulation), particularly for tightly coupled pairs.

Fig. R33 shows the results of capacitive coupling (cross-talk) between two cables.

Examples (see Fig. R34 opposite page)

- Nearby cables subjected to rapid voltage variations (dv/dt),
- Start-up of fluorescent lamps,
- High-voltage switch-mode power supplies (photocopy machines, etc.),
- Coupling capacitance between the primary and secondary windings of transformers,
- Cross-talk between cables.

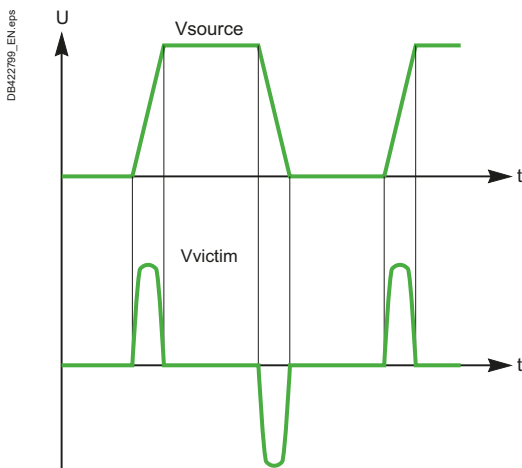


Fig. R33 Typical result of capacitive coupling (capacitive cross-talk)

4 Coupling mechanisms and counter-measures

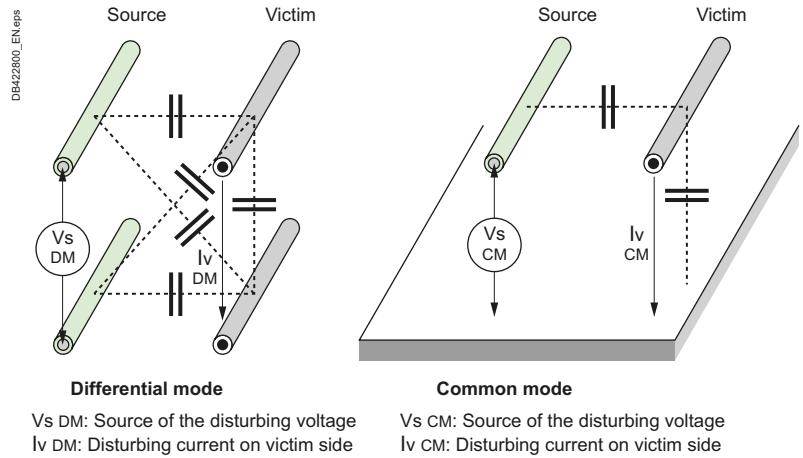


Fig. R34 Example of capacitive coupling

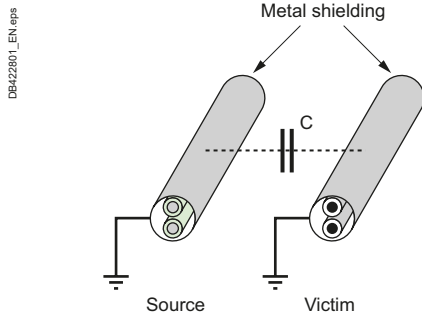


Fig. R35 Cable shielding with perforations reduces capacitive coupling

Counter-measures (see Fig. R35)

- Limit the length of parallel runs of disturbers and victims to the strict minimum.
- Increase the distance between the disturber and the victim.
- For two-wire connections, run the two wires as close together as possible.
- Position a PEC bonded at both ends and between the disturber and the victim.
- Use two or four-wire cables rather than individual conductors.
- Use symmetrical transmission systems on correctly implemented, symmetrical wiring systems.
- Shield the disturbing cables, the victim cables or both (the shielding must be bonded).
- Reduce the dv/dt of the disturber by increasing the signal rise time where possible.

4.4 Inductive coupling

Definition

The disturber and the victim are coupled by a magnetic field. The level of disturbance depends on the current variations (di/dt) and the mutual coupling inductance.

Inductive coupling increases with:

- The frequency,
- The proximity of the disturber to the victim and the length of the parallel cables,
- The height of the cables with respect to a ground referencing plane,
- The load impedance of the disturbing circuit.

Examples (see Fig. R36 next page)

- Nearby cables subjected to rapid current variations (di/dt)
- Short-circuits.
- Fault currents.
- Lightning strikes.
- Stator control systems.
- Welding machines.
- Inductors.

4 Coupling mechanisms and counter-measures

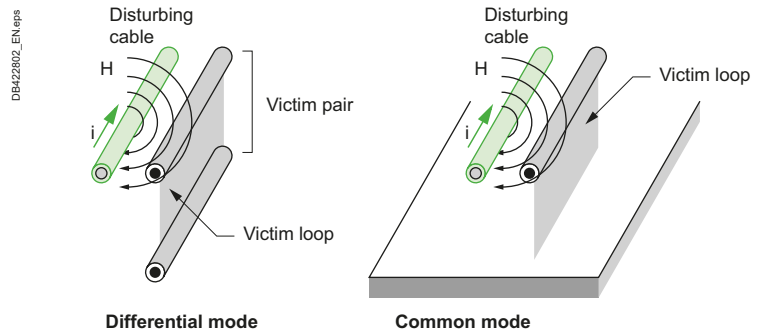


Fig. R36 Example of inductive coupling

Counter-measures

- Limit the length of parallel runs of disturbers and victims to the strict minimum.
- Increase the distance between the disturber and the victim.
- For two-wire connections, run the two wires as close together as possible.
- Use multi-core or touching single-core cables, preferably in a triangular layout.
- Position a PEC bonded at both ends and between the disturber and the victim.
- Use symmetrical transmission systems on correctly implemented, symmetrical wiring systems.
- Shield the disturbing cables, the victim cables or both (the shielding must be bonded).
- Reduce the dv/dt of the disturber by increasing the signal rise time where possible (series-connected resistors or PTC resistors on the disturbing cable, ferrite rings on the disturbing and/or victim cable).

4.5 Radiated coupling

Definition

The disturber and the victim are coupled by a medium (e.g. air). The level of disturbance depends on the power of the radiating source and the effectiveness of the emitting and receiving antenna. An electromagnetic field comprises both an electrical field and a magnetic field. The two fields are correlated. It is possible to analyse separately the electrical and magnetic components.

The electrical field (E field) and the magnetic field (H field) are coupled in wiring systems via the wires and loops (see Fig. R37).

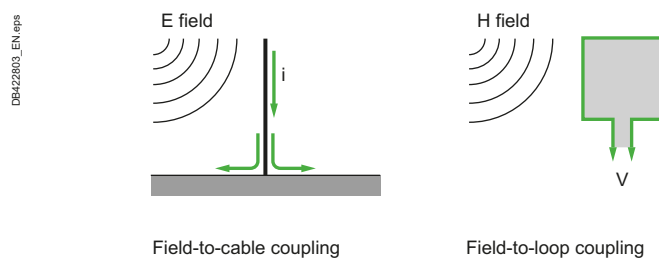


Fig. R37 Definition of radiated coupling

4 Coupling mechanisms and counter-measures

When a cable is subjected to a variable electrical field, a current is generated in the cable. This phenomenon is called field-to-cable coupling.

Similarly, when a variable magnetic field flows through a loop, it creates a counter electromotive force that produces a voltage between the two ends of the loop. This phenomenon is called field-to-loop coupling.

Examples (see Fig. R38)

- Radio-transmission equipment (walkie-talkies, radio and TV transmitters, mobile services).
- Radar.
- Automobile ignition systems.
- Arc-welding machines.
- Induction furnaces.
- Power switching systems.
- Electrostatic discharges (ESD).
- Lighting.

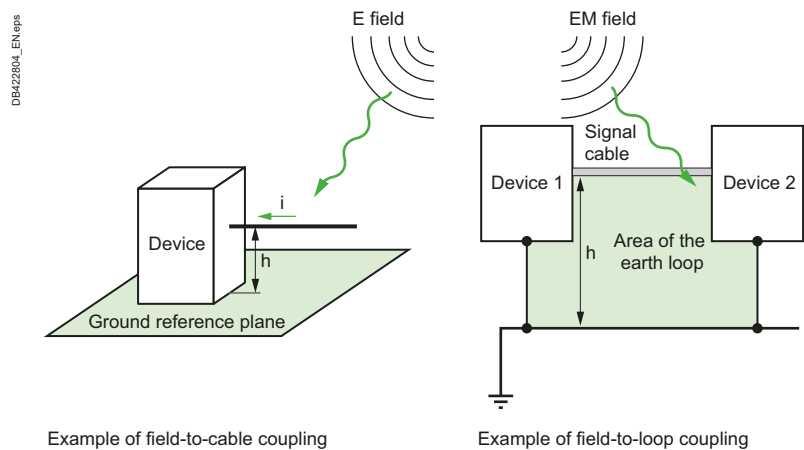


Fig. R38 Examples of radiated coupling

Counter-measures

To minimise the effects of radiated coupling, the measures below are required.

For field-to-cable coupling

- Reduce the antenna effect of the victim by reducing the height (h) of the cable with respect to the ground referencing plane.
- Place the cable in an uninterrupted, bonded metal cableway (tube, trunking, cable tray).
- Use shielded cables that are correctly installed and bonded
- Add PECs.
- Place filters or ferrite rings on the victim cable.

For field-to-loop coupling

- Reduce the surface of the victim loop by reducing the height (h) and the length of the cable. Use the solutions for field-to-cable coupling. Use the Faraday cage principle.

Radiated coupling can be eliminated using the Faraday cage principle. A possible solution is a shielded cable with both ends of the shielding connected to the metal case of the device. The exposed conductive parts must be bonded to enhance effectiveness at high frequencies.

Radiated coupling decreases with the distance and when symmetrical transmission links are used.

5 Wiring recommendations

5.1 Signal classes (see Fig. R39)

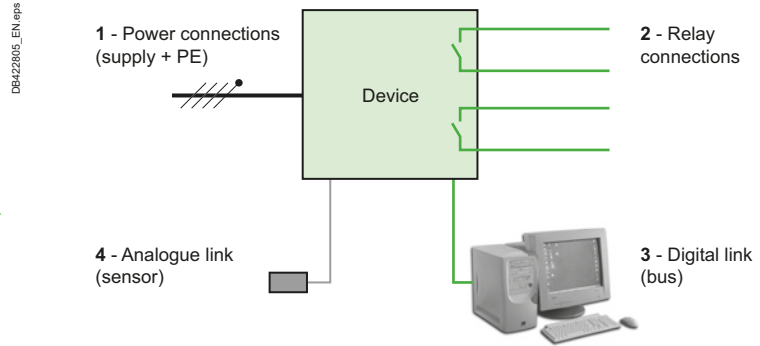


Fig. R39 Internal signals can be grouped in four classes

Four classes of internal signals are:

- Class 1
Mains power lines, power circuits with a high di/dt, switch-mode converters, power-regulation control devices.
This class is not very sensitive, but disturbs the other classes (particularly in common mode).
- Class 2
Relay contacts.
This class is not very sensitive, but disturbs the other classes (switching, arcs when contacts open).
- Class 3
Digital circuits (HF switching).
This class is sensitive to pulses, but also disturbs the following class.
- Class 4
Analogue input/output circuits (low-level measurements, active sensor supply circuits). This class is sensitive.

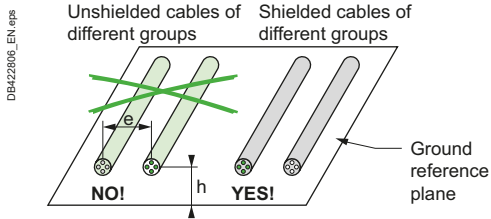
It is a good idea to use conductors with a specific colour for each class to facilitate identification and separate the classes. This is useful during design and troubleshooting.

5.2 Wiring recommendations

Cables carrying different types of signals must be physically separated (see Fig. R40)

Disturbing cables (classes 1 and 2) must be placed at some distance from the sensitive cables (classes 3 and 4) (see Fig. R40 and Fig. R41)

In general, a 10 cm separation between cables laid flat on sheet metal is sufficient (for both common and differential modes). If there is enough space, a distance of 30 cm is preferable. If cables must be crossed, this should be done at right angles to avoid cross-talk (even if they touch). There are no distance requirements if the cables are separated by a metal partition that is equipotential with respect to the ECPs. However, the height of the partition must be greater than the diameter of the cables.



Risk of cross-talk in common mode if $e < 3h$

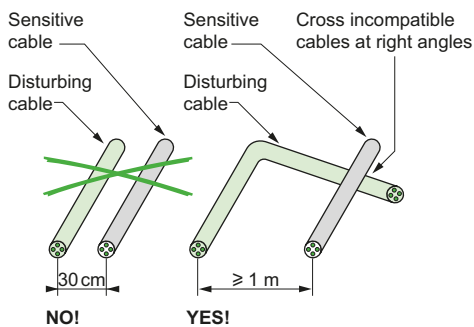


Fig. R40 Wiring recommendations for cables carrying different types of signals

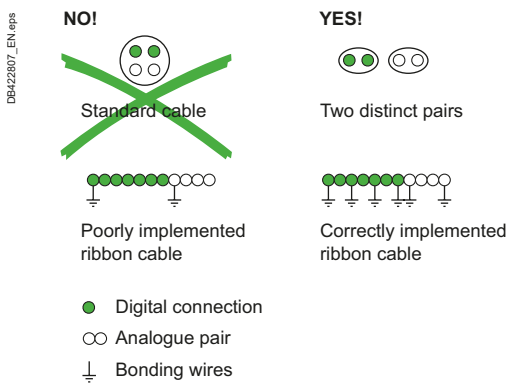


Fig. R41 Use of cables and ribbon cable

5 Wiring recommendations

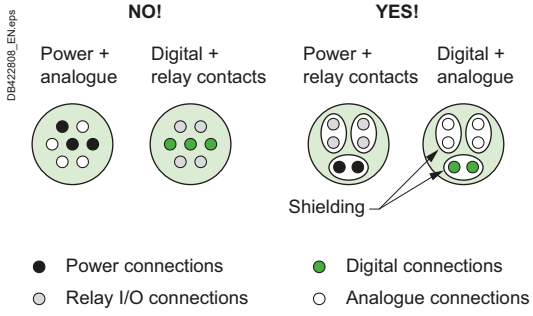


Fig. R42 Incompatible signals = different cables

A cable should carry the signals of a single group (see Fig. R42)

If it is necessary to use a cable to carry the signals of different groups, internal shielding is necessary to limit cross-talk (differential mode). The shielding, preferably braided, must be bonded at each end for groups 1, 2 and 3.

It is advised to overshield disturbing and sensitive cables (see Fig. R43)

The overshielding acts as a HF protection (common and differential modes) if it is bonded at each end using a circumferential connector, a collar or a clamp. However, a simple bonding wire is not sufficient.

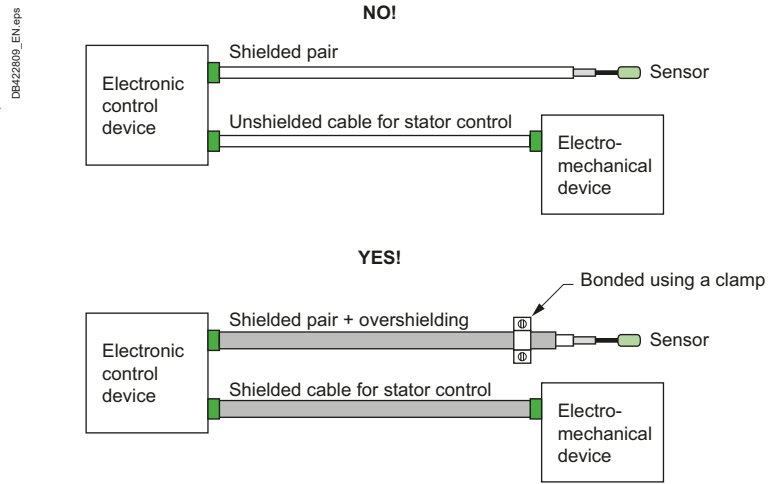


Fig. R43 Shielding and overshielding for disturbing and/or sensitive cables

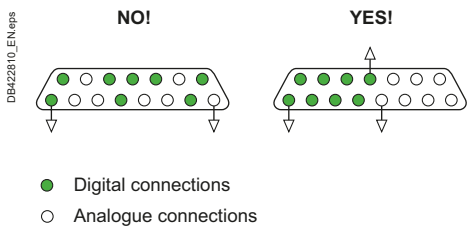


Fig. R44 Segregation applies to connectors as well!

Avoid using a single connector for different groups (see Fig. R44)

Except where necessary for groups 1 and 2 (differential mode). If a single connector is used for both analogue and digital signals, the two groups must be separated by at least one set of contacts connected to 0 V used as a barrier.

All free conductors (reserve) must always be bonded at each end (see Fig. R45)

For group 4, these connections are not advised for lines with very low voltage and frequency levels (risk of creating signal noise, by magnetic induction, at the transmission frequencies).

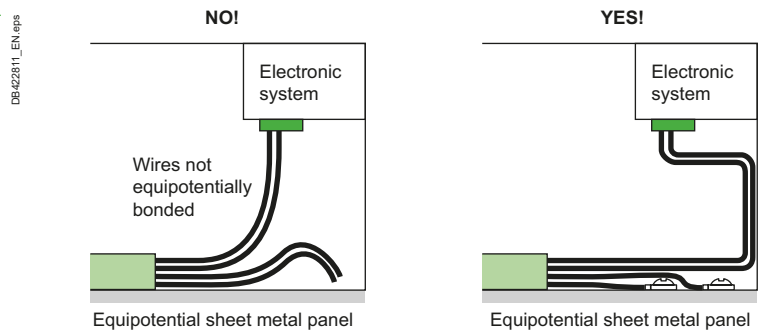


Fig. R45 Free wires must be equipotentially bonded

5 Wiring recommendations

The two conductors must be installed as close together as possible (see Fig. R46)

This is particularly important for low-level sensors. Even for relay signals with a common, the active conductors should be accompanied by at least one common conductor per bundle. For analogue and digital signals, twisted pairs are a minimum requirement. A twisted pair (differential mode) guarantees that the two wires remain together along their entire length.

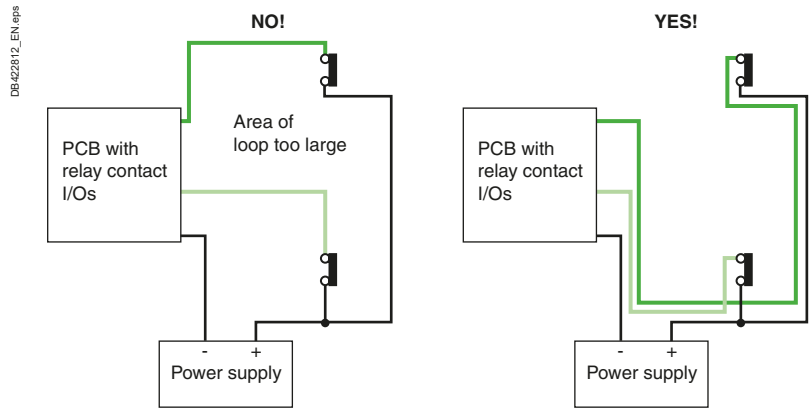


Fig. R46 The two wires of a pair must always be run close together

Group-1 cables do not need to be shielded if they are filtered

But they should be made of twisted pairs to ensure compliance with the previous section.

Cables must always be positioned along their entire length against the bonded metal parts of devices (see Fig. R47)

For example: Covers, metal trunking, structure, etc. In order to take advantage of the dependable, inexpensive and significant reduction effect (common mode) and anti-cross-talk effect (differential mode).

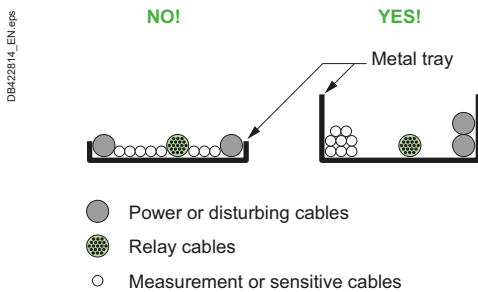


Fig. R48 Cable distribution in cable trays

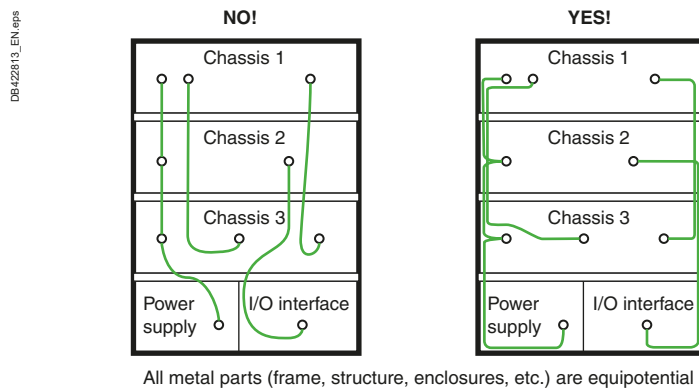


Fig. R47 Run wires along their entire length against the bonded metal parts

The use of correctly bonded metal trunking considerably improves internal EMC (see Fig. R48)

Chapter S

Measurement

1	Measurement applications	S2
2	Description of applications	S3
	2.1 Energy efficiency and cost savings	S3
	2.2 Power availability and reliability.....	S4
	2.3 Grid power quality.....	S5
	2.4 Billing	S6
	2.5 Cost allocation, bill checking and sub-billing	S6
3	Focus on IEC 61557-12 standard	S7
	3.1 PMD functions	S7
	3.2 Marking.....	S8
	3.3 Uncertainty over a measuring range	S8

1 Measurement applications

This chapter is an introduction to the different applications of measurements, and to the main standards relevant for these different applications.

There are different kinds of application that need measurement. Basically, applications can be split between 5 categories, as described in **Fig. S1**.

DE422830_EN.eps

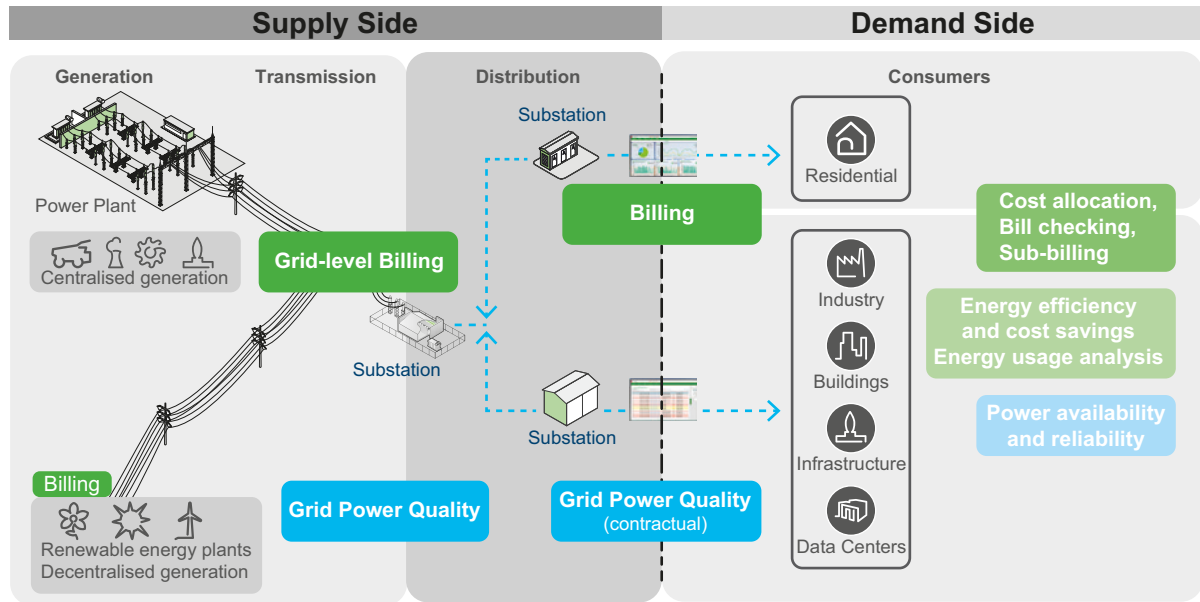


Fig. S1 The five main measurement applications in relationship to the supply side and the demand side

2 Description of applications

2.1 Energy efficiency and cost savings

For this application, energy needs to be measured in order to make it more efficient, to allocate it within a plant, or to reduce its cost.

Energy efficiency aspects are dealt with in more details in chapter K.

The main standards are specified below.

See also recommendations provided in [Focus on IEC 61557-12 standard](#).

Assessment of a complete site	Assessment tools	Devices used to assess the site
ISO ISO 50001 Energy Management Systems – Requirements with guidance for use	ISO ISO 50006 Energy Baseline (EnBs) & Energy Performance Indicators (EnPIs)	PMD (Power Meters) IEC IEC 61557-12 Power Metering and Monitoring devices (PMD)
	IEC IEC 60364-8-1 Low voltage installations – Part 8-1: Energy Efficiency	Gateways, energy servers, data loggers IEC IEC 62974-1 Monitoring and measuring systems used for data collection, gathering and analysis – Part 1: Device requirements
	afnor FD X30-147^[a] Measurement plan for energy performance monitoring	

[a] FD X30-147 is a guide published by AFNOR (French national organization for standardization), which specifies the requirements, methodology and deliverables for the design, implementation, operation, maintenance and improvement of a metering system.

Fig. S2 Standards for Energy Efficiency, cost allocation & optimization

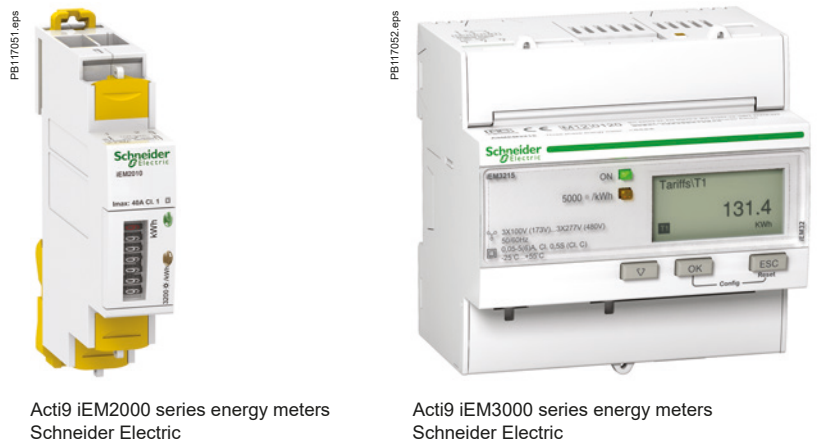


Fig. S3 Examples of products compliant with IEC 61557-12, for Energy Efficiency

2 Description of applications

2.2 Power availability and reliability

In order to operate an electrical installation, it is recommended that measurement of the main characteristics of the supply such as voltage, current, frequency, and/or active power are provided as a minimum.

Some electrical phenomena can have an impact on both installation assets and operations within a plant (e.g. unbalance can reduce the life time of motors, dips can stop a process, etc.)

The following table describes the main problems that can occur in a network:

Parameter	Measurement	Influence on installation energy efficiency	Influence on installation performance
Power Factor (PF or $\cos \varphi$)	PF	Low PF generates additional losses in the installation. Energy provider is charging penalties to the customer	Cables heating (cables need to be oversized)
Voltage and current harmonics	THDu THDi	Negative sequence harmonics (u2) are slowing motors down. Harmonics generates extra losses in the installation	Early failure of some devices, mainly motors
Permanent or frequent deviations of voltage	U	Devices may work outside their specified range, and they may over consume, mainly motors	Early failure of some devices, mainly motors
Voltage unbalance	Uimb	Voltage unbalance generates extra losses in motors.	Early failure of some devices, mainly motors
Dips and interruptions	Udip Uint	---	Process interruption with financial impacts
Frequency	f	---	Rotating machines may change their speed according to frequency
Flicker or RVC	Pst RVC	---	These phenomena can generate disturbing phenomena on lighting

Fig. S4 Main problems that can occur in an electrical network, and their potential consequences

S4

The main standards are specified below:






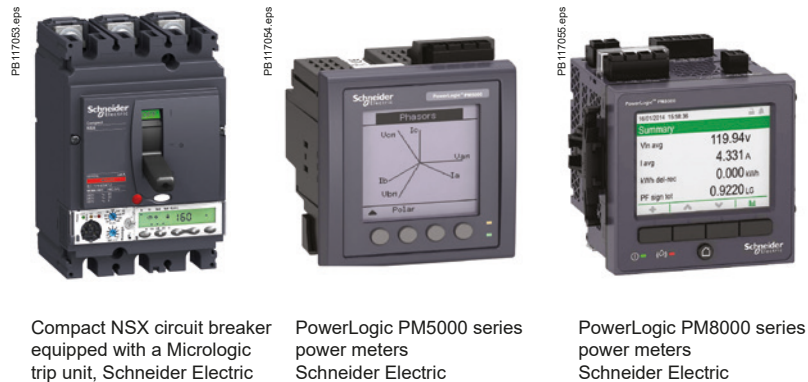
Installation needs /standard	Measuring methods standard	Product standard
Voltage, current and frequency indication	---	Analog meters  IEC 60051 Direct acting indicating analog electrical measuring instruments
Electrical Distribution Monitoring	---	PMD (Power Meters)  IEC 61557-12 Power Metering and Monitoring devices (PMD)
	 IEC 61000-4-30 Testing and measuring techniques – Power quality measurement methods	PMD (Power Meters) with class A or S methods  IEC 61557-12 Power Metering and Monitoring devices (PMD) and  IEC 62586-2 NEW Power quality measurement in power supply systems - Functional tests and uncertainty requirements (Compliance to IEC 62586-2 means compliance to IEC 61000-4-30)

Fig. S5 Standards for power availability and reliability

2 Description of applications



Compact NSX circuit breaker equipped with a Micrologic trip unit, Schneider Electric

PowerLogic PM5000 series power meters Schneider Electric

PowerLogic PM8000 series power meters Schneider Electric

Fig. S6 Examples of products compliant with IEC 61557-12, for Electrical Distribution Monitoring

2.3 Grid power quality

Some regulations or specific contracts require energy providers to keep voltage characteristics at any supply terminal within specified limits. These specifications cover limits or values related to voltage, frequency, rapid voltage changes, harmonics, interharmonics, unbalance, dips, swells, interruptions, flicker, ...

Measurements are typically made on the energy provider side (to check delivered energy complies to the contract) and on the consumer side (to check received energy complies with the contract) with Power Quality Instruments class A according to IEC 61000-4-30.

Application assessment standard	Measuring methods standard	Product standard
<p>GENELEC EN 50160 Voltage characteristics of electricity supplied by public electricity networks</p> <p>IEC IEC/TS 62749 NEW Assessment of Power Quality – Characteristics of electricity supplied by public electricity networks</p>	<p>IEC IEC 61000-4-30 class A Testing and measuring techniques – Power quality measurement methods</p>	<p>PQI (Power Quality Instruments)</p> <p>IEC IEC 62586-1 NEW Power quality measurement in power supply systems - Power Quality Instruments (PQI)</p> <p>and</p> <p>IEC IEC 62586-2 NEW Power quality measurement in power supply systems - Functional tests and uncertainty requirements (Compliance to IEC 62586-2 means compliance to IEC 61000-4-30)</p>

Fig. S7 Standards for Grid power quality assessment



PowerLogic ION7550/ION7650 Power Quality Device Schneider Electric

PowerLogic ION8800 Power Quality Device Schneider Electric

PowerLogic ION8650 Power Quality Device Schneider Electric

Fig. S8 Examples of products compliant with IEC 61000-4-30 for Grid Power Quality

2 Description of applications

2.4 Billing

Billing is the process that allows energy suppliers or their representatives to invoice their customers according to a defined contract, for measured usages or services.

These applications are covered by international, regional or local standards in addition to utility specifications. Regulations such as MID in Europe or NMI M-6 in Australia, LBM-EG-07 in Canada, JJG 596 in China... can apply additionally.

Devices for billing applications are devices with specific legal metrology requirements, and are then subject to specific requirements such as periodic verification (usually every 6 to 10 years) according to local regulations.

2.5 Cost allocation, bill checking and sub-billing

Sub-billing is the process that allows a landlord, property management firm, condominium association, homeowner association or other multi-tenant property to spread out an invoice over tenants, for measured usages or services. This fee is usually combined with other fees within a tenant's facility fee.

Since the meter used for sub billing is typically installed in electrical room not accessible by the tenant, the risk of fraud is very limited. This is why devices complying with IEC 61557-12 as well as devices used for billing applications can be used for sub-billing applications. Attention should be put on environmental aspects where the device used for sub-billing needs to fit EMC, temperature and mechanical environment. In any case, measuring devices used in for sub-billing in switchboards and panels need to comply with IEC 61557-12.

Cost allocation is the process that allows a facility manager to allocate energy costs to internal cost centers that consume energy (e.g. plants, workshop, ...)

Bill checking is the process that allows customers to check invoice sent by energy suppliers or their representatives is correct.

3 Focus on IEC 61557-12 standard

Increasingly, digital equipment is replacing analog equipment in electrical installations. It supports more accurate measurement of new values and is able to make these available to users at both local and remote locations.

Devices intended to perform monitoring have various characteristics which require a shared reference system. This system must allow users to make easier choices in terms of performance levels, dependability and to interpret different measured parameters.

All these various measuring devices (referred to as "PMD" for "Power Metering and Monitoring Device") have to meet the requirements of international standard IEC 61557-12: "Electrical safety in low voltage distribution systems up to 1000 V a.c. and 1500 V d.c. – Equipment for testing, measuring or monitoring of protective measures – Part 12: Power Metering and monitoring devices (PMD)".

The standard gives a list of the main requirements applicable to PMD with guidance about sensors to use (in case sensors are requested).

3.1 PMD functions

All the possible electrical parameters to be measured are listed.

For each parameter, a list of requirements is specified, such as the rated range of operation, the range of influence quantities, the measurement techniques, etc.

The considered electrical parameters are given here:

- Active energy (classes are equivalent to the classes defined in IEC 62053-21 and IEC 62053-22),
- Reactive energy (classes are equivalent to the classes defined in IEC 62053-23)
- Apparent energy,
- Active, reactive and apparent power,
- Frequency,
- r.m.s. phase and neutral current,
- r.m.s. voltage,
- Power factor,
- Voltage dip and swell,
- Voltage interruption,
- Voltage unbalance,
- Harmonic voltage and distortion,
- Harmonic current and distortion,
- Maximum, minimum, peak, average, demand and values.

3 Focus on IEC 61557-12 standard

3.2 Marking

According to this standard, devices have a code denoting their installation options, operating temperature range and accuracy class. As a result, it has become significantly easier to select and identify these devices (see Fig. S9).

PowerLogic PM8000 series power meter complying with IEC 61557-12 as: PMD/SD/K70/0,2 and PMD/SS/K70/0,2

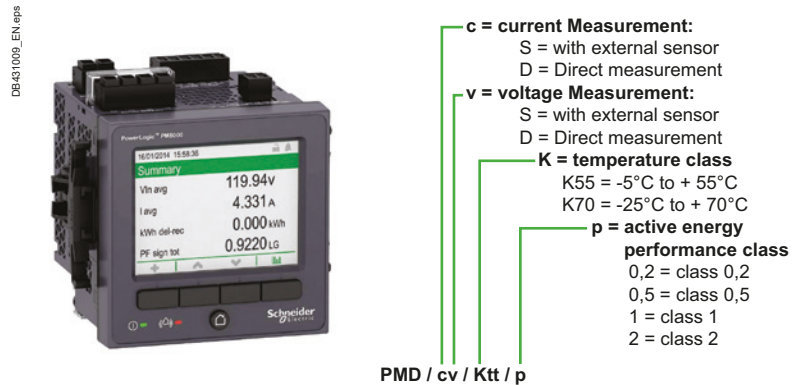


Fig. S9 Identifying measuring devices in accordance with IEC 61557-12

3.3 Uncertainty over a measuring range

The notion of performance classes (e.g. class 1 for active energy measurement) specified by IEC 61557-12 is much more than a requirement related to uncertainty at nominal current.

- intrinsic uncertainty: compliance covers performance under two sets of reference conditions
- operating uncertainty: compliance covers performance under 12 environmental and electromagnetic influence quantities which typically affect PMD operation
- overall system uncertainty: some information is provided about how to estimate uncertainty of a PMD operating with external sensors.

3.3.1 Intrinsic uncertainty

Intrinsic uncertainty is the uncertainty of a measuring instrument when used under reference conditions (e.g. at 23°C) for different Power Factor values. In this standard, it is a percentage of the measured value (readings).

Fig. S10 specifies intrinsic uncertainty limits for class 1 and class 0,2 active energy measurement at Power Factor = 1, according to Table 8 of IEC 61557-12.

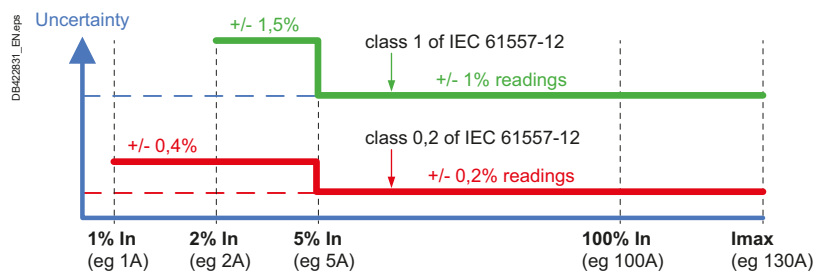


Fig. S10 Uncertainty limits for active energy at Power Factor = 1

3 Focus on IEC 61557-12 standard

Fig. S11 specifies intrinsic uncertainty limits for class 1 and class 0,2 active energy measurement at Power Factor = 0,5 inductive and 0,8 capacitive, according to Table 8 of IEC 61557-12.

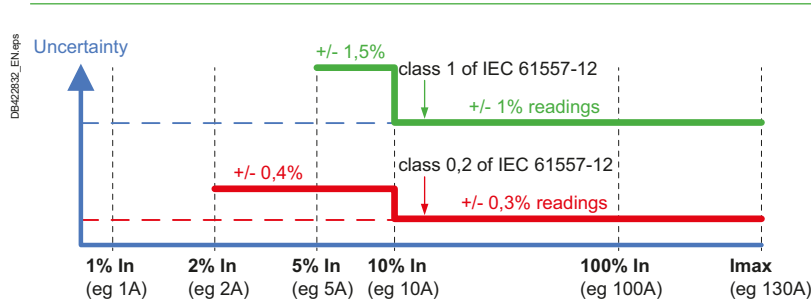


Fig. S11 Uncertainty limits for active energy at Power Factor = 0,5 inductive and 0,8 capacitive

IEC 61557-12 also specifies requirements about no-load conditions and starting current.

3.3.2 Operating uncertainty (based on variations due to influence quantities)

Operating uncertainty is the uncertainty under the rated operating conditions (including drifts related to temperature, frequency, EMC, ...)

IEC61557-12 specifies tests and uncertainty maximum variation of uncertainty due to various influence quantities such as ambient T°, frequency, unbalance, harmonics and EMC.

Influence quantities	Maximum uncertainty variation for active energy measurements according to table 9 of IEC 61557-12		
	Conditions	for class 1	for class 0,2
Ambient T°	PF = 1 PF = 0,5 Ind	0,05% / °K 0,07% / °K	0,01% / °K 0,02% / °K
Aux Power supply	24Vdc +/-15%	0,1%	0,02%
Voltage	PF = 1; 80% / 120% Un PF = 0,5Ind; 80% / 120% Un	0,7% 1%	0,1% 0,2%
Frequency	49Hz 51Hz / 59Hz 61Hz PF = 1 49Hz 51Hz / 59Hz 61Hz PF = 0,5	0,5% 0,7%	0,1% 0,1%
Reversed phase sequence		1,5%	0,05%
Voltage unbalance	0 to 10%	2%	0,5%
Phase missing	One or 2 phase missing	2%	0,4%
Harmonic in current and voltage	10%Un 5th 20%Imax 5th Odd harmonic in current Odd harmonic in tension	0,8% 3% 3%	0,38% 0,6% 0,6%
Common mode voltage rejection		0,5%	0,2%
Permanent a.c. magnetic induction 0,5 mT		2%	2%
Electromagnetic RF fields		2%	0,98%
Conducted disturbances induced by RF fields		2%	0,98%

Fig. S12 Tests related to influencing quantities



Green Premium™

Endorsing eco-friendly products in the industry



Green Premium™ Product

Green Premium is the only label that allows you to effectively develop and promote an environmental policy whilst preserving your business efficiency. This ecolabel guarantees compliance with up-to-date environmental regulations, but it does more than this.

Over 75% of Schneider Electric manufactured products have been awarded the Green Premium ecolabel



Discover what we mean by green ...

Check your products!

Schneider Electric's Green Premium ecolabel is committed to offering transparency, by disclosing extensive and reliable information related to the environmental impact of its products:

RoHS

Schneider Electric products are subject to RoHS requirements at a worldwide level, even for the many products that are not required to comply with the terms of the regulation. Compliance certificates are available for products that fulfil the criteria of this European initiative, which aims to eliminate hazardous substances.

REACH

Schneider Electric applies the strict REACH regulation on its products at a worldwide level, and discloses extensive information concerning the presence of SVHC (Substances of Very High Concern) in all of its products.

PEP: Product Environmental Profile

Schneider Electric publishes complete set of environmental data, including carbon footprint and energy consumption data for each of the lifecycle phases on all of its products, in compliance with the ISO 14025 PEP ecopassport program. PEP is especially useful for monitoring, controlling, saving energy, and/or reducing carbon emissions.

EoLI: End of Life Instructions

Available at the click of a button, these instructions provide:

- Recyclability rates for Schneider Electric products.
- Guidance to mitigate personnel hazards during the dismantling of products and before recycling operations.
- Parts identification for recycling or for selective treatment, to mitigate environmental hazards/ incompatibility with standard recycling processes.

Notes

A series of horizontal dotted lines for writing notes.

Life Is On

Schneider
Electric

Schneider Electric Industries SAS

35, rue Joseph Monier
CS 30323
92506 Rueil Malmaison Cedex
France

RCS Nanterre 954 503 439
Capital social 928 298 512 €
www.schneider-electric.com

09-2018
ART. 822690

© 2018 - Schneider Electric. All Rights Reserved.
All trademarks are owned by Schneider Electric Industries SAS or its affiliated companies.
Document reference: EIGED306001EN

This document has been
printed on recycled paper

